



Product: R&S CMU300

R&S[®] CMU300 Radio Communication Tester for 2G/3G Base Stations

WCDMA / HSDPA Signalling Mode

Application Note

The R&S CMU300 combines high-precision Node B parameter tests with layer 1 signalling processes for the first time. Thus, you can now test Node Bs under more realistic conditions as it was possible with existing concepts. This document describes the new measurement functions and provides an overview of their applications.



Content

1	Introduction.....	2
2	Synchronization and Triggering.....	3
3	BCH Monitoring	5
4	BER/BLER Tests	5
5	RACH Test	7
6	Realtime HS-SCCH Monitoring.....	9
7	Realtime HSDPA Throughput Measurement	10
8	HSDPA Uplink Generator.....	12
9	HSDPA “Stimulate & Check” Testing	13
10	References	13
11	Abbreviations.....	14
12	Ordering Information.....	15

1 Introduction

The increasing use of fast UMTS data services is making the time aspects of Node B tests more important. Static tests are currently being performed to find out whether the values of essential Node B transmit parameters (power, modulation, spectrum, code domain) meet specifications. However, increasing data throughput rates additionally require that correct radio channel parameters are also set at the right time. RF parameter tests are now combined with layer 1 signalling processes within a Node B tester, i.e. the R&S CMU300, by means of a newly developed WCDMA realtime receiver.

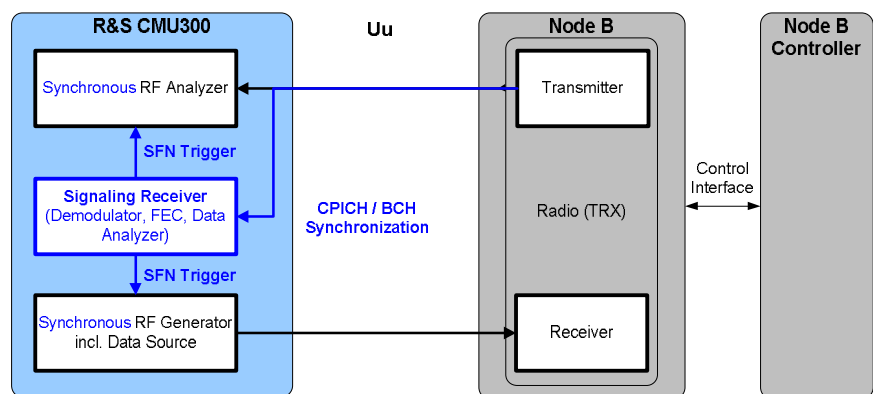

The Signalling mode, in which the R&S CMU300 synchronizes itself to the Node B cell channels, offers the following advantages:

- Simplification of the test setup since only RF connections are required and since previously required Node B trigger interfaces can now be omitted.
- Availability of the following measurement functions which were previously not feasible or which required significant technical and financial efforts:

R&S CMU300 3GPP FDD Signalling Mode

- ∅ Time-synchronous TX measurements that can detect critical moments when switching the radio channel parameters
- ∅ An R&S CMU300 trigger output for synchronizing further measurement instruments (spectrum analyzers, signal generators)
- ∅ Analysis of BCH information (SIBs)
- ∅ BER and BLER analysis of downlink RMCs and data loop tests
- ∅ RACH preamble test, including AICH evaluation

Test and measurement solutions for user equipment (UE) and networks significantly help to ensure that the introduction of HSDPA runs smoothly. Besides the intensive testing of UE, intensive tests for the introduction of HSDPA are required in the network itself. Additionally to HSDPA TX parametric tests the R&S CMU300 allows you to check HSDPA-specific settings on Node B. Supported applications:

- ∅ HS-SCCH monitor
- ∅ HSDPA throughput measurement
- ∅ HS-DPCCH stimulation on uplink
- ∅ HSDPA “stimulate & check” procedures

2 Synchronization and Triggering

Before time synchronization can be performed, Node B must first activate the CPICH and the BCH (mapped on P-CCPCH) cell channels. You have to know the primary scrambling code and set it manually on the R&S CMU300. Start synchronization by using the *Start Sync* key in the *Connection Control* menu/*Connection* tab.

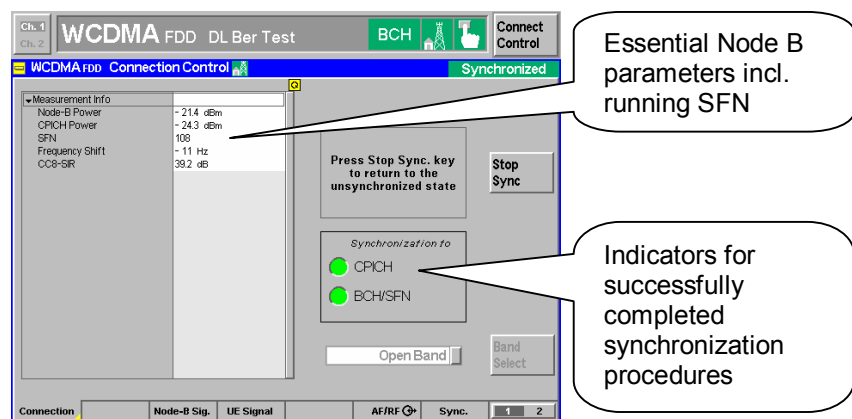

By registering the Node B system clock, you can now start transmitter measurements at specific points in time without additional external triggering. Thus, you can exactly analyze changes in modulation mode, for example. You can also synchronously start the UL generator, such as during BER tests.

3GPP FDD/HSDPA TX measurements of the R&S CMU300:

Power:

- Power meter (wideband or frequency selective)
- CDP

Modulation:

- EVM incl. magnitude/phase error
- Carrier frequency error
- I/Q origin offset
- I/Q imbalance
- Waveform quality
- PCDEP

Spectrum:

- ACLR
- OBW
- SEM

The internal R&S CMU300 start trigger is set via the *Connection Control* menu/*Trigger* tab/*Trigger Configuration/Int. Superframe Tr.* The *Start SFN* parameter determines the beginning of the first measurement, and the *Period* parameter determines the repetition period.

The screenshot shows the 'WCDMA FDD Code Domain Power' menu with the 'BCH' sub-menu selected. The 'Connection Control' window is open, showing the 'Trigger' tab. The 'Setup' window is displayed, showing the 'Output Trigger/Pin 5' configuration. The 'Start SFN' is set to 0 and the 'Period' is set to 4096. The 'Output Trigger' section is expanded, showing the 'HS UE-ID Tr.' option selected. Callouts indicate the setting of the first trigger pulse and repetition period, and the configuration of the trigger output.

You can make this trigger accessible to other instruments via the AUX3 front panel connector by setting it by means of the *Output Trigger* parameter in the same menu.

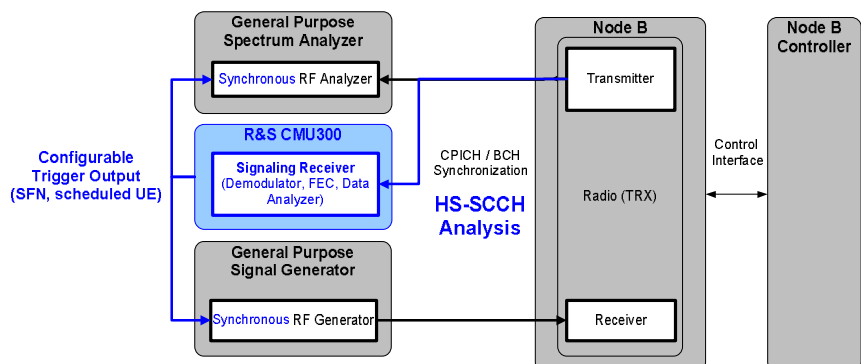

3 BCH Monitoring

The BCH monitoring function offers a convenient means of performing online analysis of the cell system information (SIBs).

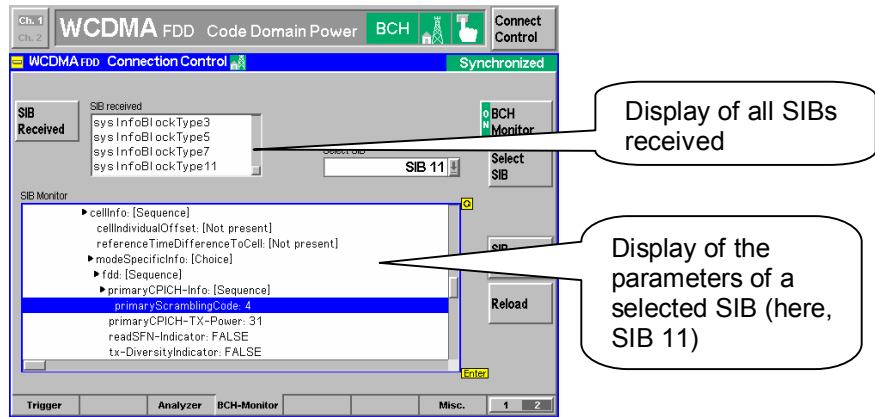

4 BER/BLER Tests

In the past, bit error ratio (BER) tests were mainly used to characterize the receive characteristics of the Node B. The realtime receiver in the R&S CMU300 significantly expands this function by also enabling you to test the downlink in the same way. In contrast to pure RF parameter measurements, the entire layer 1 is measured, including the FEC.

These two scenarios are possible:

- Separate measurement of the BTS downlink and uplink. This requires that the DL data source and UL data analyzer are provided by the Node B controller. You can use different RMC types and data contents for the downlink and uplink.
- Simultaneous measurement of both links by using a data loop (transport layer) in the Node B or in its controller. You have to use the same RMC type and data content for both links.

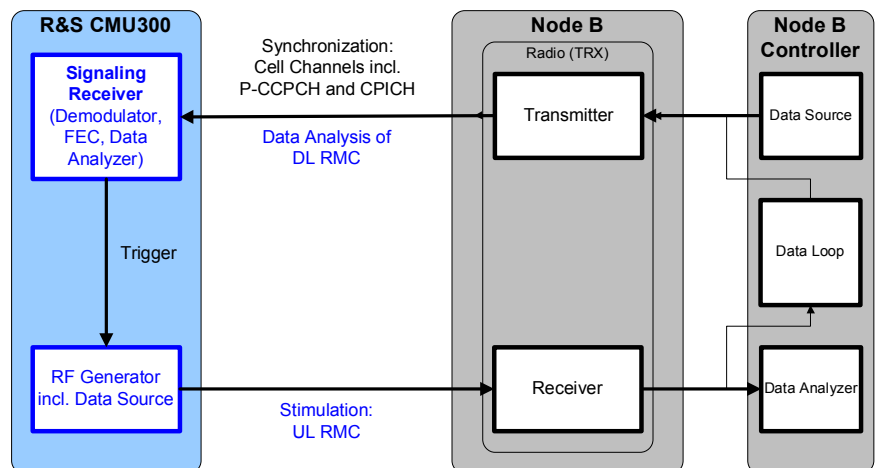

Functionality

UL generator: UE simulation

- Supported RMCs: 12.2/64/144/384/2048 kbps
- Data content (transport layer): PRBS 9/11/15/16
- Output level accuracy < 0.6 dB (in the level range -80 dBm to -125 dBm)
- Optional: AWGN generator function und simulation of bit errors

DL analyzer: DCH evaluation

- Supported RMCs: 12.2/64/144/384/2048 kbps
- Data content (transport layer): PRBS 9/11/15/16
- Single shot measurement with up to 100 000 transport blocks
- Continuous measurement with running averaging via a window of up to 10 000 transport blocks
- Alternatively, the DL data analyzer can automatically resynchronize after loss of synchronization. The number of the synchronizations is counted when this is done. (*PN Autoresync.* function).

Measurement Results

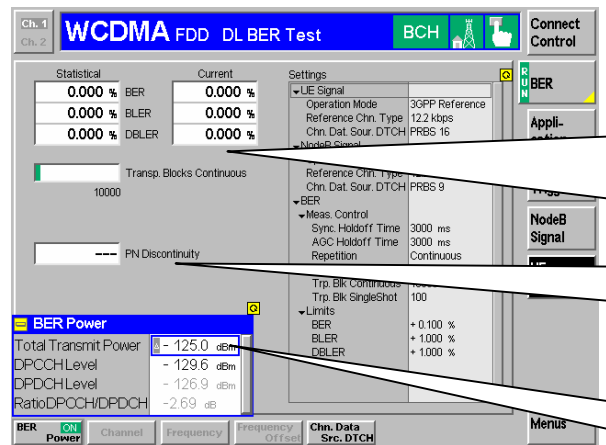

DL RMC data analysis (here, continuous measurement with averaging over 10 000 transport blocks)

Number of resynchronizations in the PN Autosync mode

Activation and level setting of the UL generator

BER Bit error ratio, ratio of data bit errors to total number of transferred data bits.

BLER Block error ratio, ratio of blocks received with incorrect data or CRC bits to total number of received blocks

DBLER Data block error ratio, ratio of blocks received with incorrect data bits to total number of received blocks

5 RACH Test

The compact tester concept with data generator and data analysis in one instrument allows you to perform test scenarios that check for correct Node B responses to UE queries in realtime. Accordingly, the *RACH preamble test* of the R&S CMU300 is carried out in accordance with the ETSI specification 3GPP TS 25.141 FDD, chapter 8.8.1 as follows:

- Start of the transmission of a predefined number of preambles. An AWGN signal can also be superimposed on these preambles.
- Analysis of the Node B response by means of the AICHs received, including calculation of the probability of detection of preamble (P_d) and probability of false detection of preamble (P_{fa}).

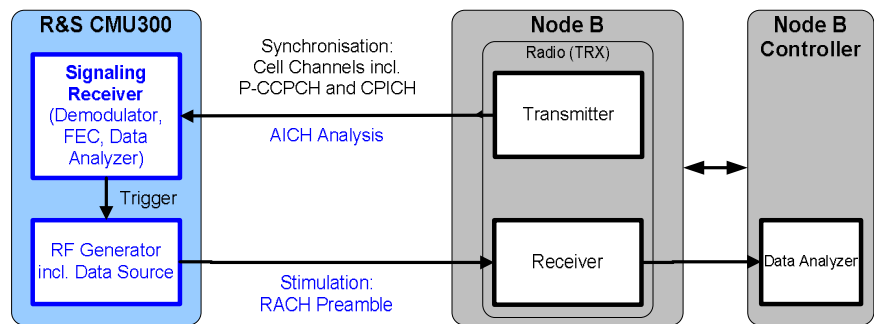

Preamble Configuration

- Fixed scrambling code and level for all preambles to be sent.
- Capability to inject an AWGN signal and directly set a defined E_c/N_0 .
- Variable total number of the preambles to be sent: 1 to 2^{24} .
- Capability to set the starting time of first preamble to be sent.
- Capability to define a repeating preamble sequence with up to 64 predefined preambles for each sequence.
- Variable access frame number, access slot and signature for each preamble within the sequence.

R&S CMU300 3GPP FDD Signalling Mode

Example AICH Preamble Configuration and timing:

Access Frame No.	Access Slot	Signature
0	0	9
0	1	2
1	8	3
1	9	5
0	5	7
0	6	1

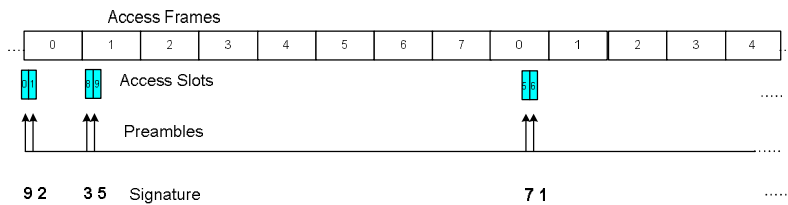

AICH Analysis

100.000 Pd	Settings
0.000 Pfa	Common
2581 Correct AICHs	Noise Power - 20.0 dBm
0 Wrong AICHs	AICHN On
2581 Detected AICHs	AICH Tx Timing 0
-40.80 dBm AICH Average Power (Current)	Meas. Control
	Power - 14.4 dBm
	Ec/N0 5.6 dB
	Scrambling Code 0
	Nr. of Preambles 100000
	AICH Spread Code 6
	Act. SFN Mode SFN Number
	Act. SFN Number 0
	Exp. Power/Trigger
	Mode Manual
	Expected Power - 20.0 dBm
	Attenuation Low Noise
	Trigger Source Free run
	Node B Signal
	Frequency 21126 MHz
	Channel 10963 Ch
	Frequency Offset 0.000 kHz

Pd: Correct AICHs / number of RACH preambles sent up to now.

Pfa: Incorrect AICHs / number of access slots analyzed by Node B up to now.

Correct AICHs: Number of AICHs received with correct signature and at right time.

Wrong AICHs: Number of AICHs received either at incorrect time or with incorrect signature.

Detected AICHs: Total number of AICHs received up to now. Total from Correct & Wrong AICHs.

AICH Average Power: Average AICH power determined from the total of all current AICH levels / detected AICHs.

6 Realtime HS-SCCH Monitoring

The high-speed shared control channel (HS-SCCH) is important for communication in HSDPA mode. It transfers information about the nature of the following data channel (HS-PDSCH) as well as information indicating which UE the data packet is specified for. The information applies to the following:

- Channelization code set
- Modulation scheme
- Transport block size
- HARQ process
- Redundancy and constellation
- New data indicator
- UE-ID

Several HS-SCCHs may be transmitted simultaneously. The R&S CMU300 thus not only monitors the HS-SCCHs but also analyzes whether the communication in HSDPA mode is taking place correctly.

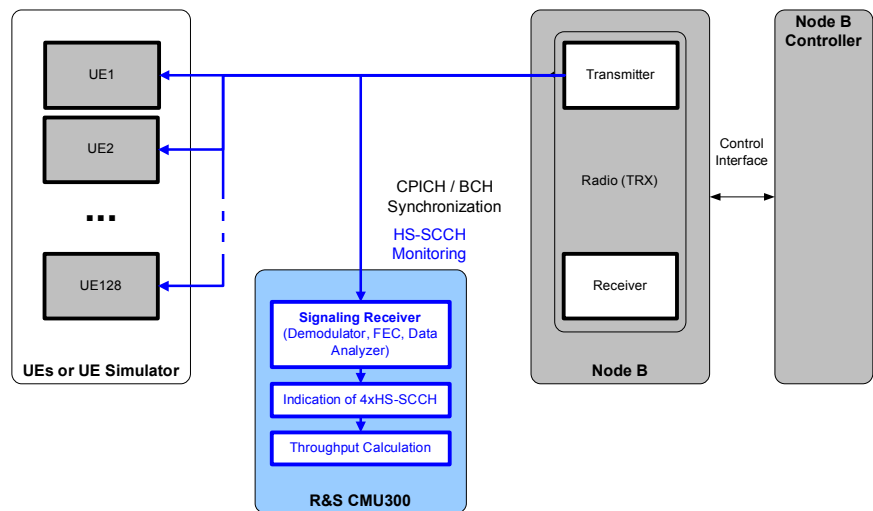

Setup for HSDPA monitoring and throughput measurements

The R&S CMU300 can simultaneously monitor up to four HS-SCCH channels. The code channels to be monitored can be selected by the user. Moreover, the R&S CMU300 can detect up to 128 different UE-IDs. The UE-IDs to be detected can be determined by means of a list. The information of the detected HS-SCCHs is displayed directly on the R&S CMU300's user interface as follows:

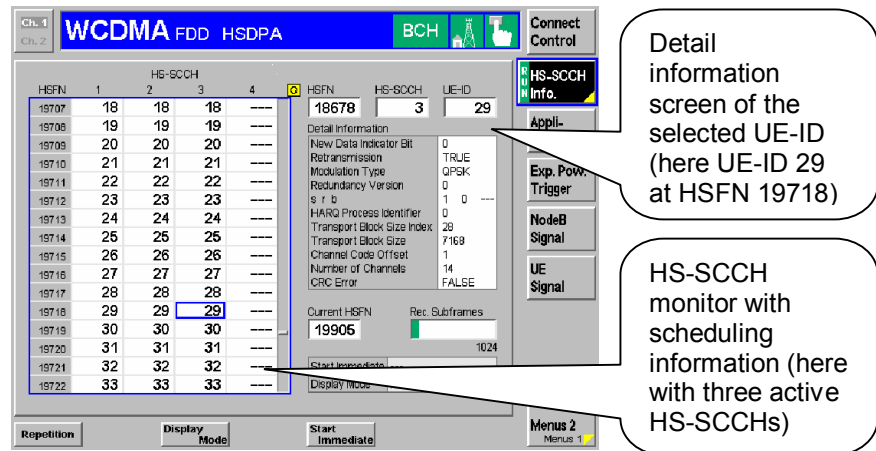

GUI HS-SCCH monitoring

The HS-SCCH information measurement can be performed after successful CPICH/BCH synchronization in different modes:

Start mode

- Start Immediate:** Capturing starts right after the user starts the measurement.
- Start at HSFN:** Capturing starts when the specified start HSFN is reached.
- Start at UE-ID:** Capturing starts when the specified start UE-ID is detected the first time.

Repetition mode

- Single Shot:** The measurement is stopped after 1024 HSFNs are captured (depending on display mode).
- Continuous:** Continuous capturing of data until the measurement is explicitly stopped by the user.

Display mode

- Result Table vs. HSFN:** The monitored HSFNs are displayed continuously.
- Result Table vs. UE-ID:** Only HSFNs containing data are displayed.

7 Realtime HSDPA Throughput Measurement

The Cell Throughput application measures the HS-PDSCH data rate and throughput by analyzing the HS-SCCH information. Up to four HS-SCCHs and 128 different UE-IDs can be monitored and displayed in realtime. The HS-SCCH channel numbers and UE-IDs to be detected can be determined by means of lists. For each monitored UE-ID, the current throughput, the average throughput and the maximum/minimum values are analyzed. By evaluating the new data indicator flag, data rate and throughput are differentiated and displayed.

R&S CMU300 3GPP FDD Signalling Mode

The throughput measurement can be performed after successful CPICH/BCH synchronization in different modes:

Start mode

- Start Immediate:** The throughput measurement starts right after you press the Start button.
- Start at HSFN:** The measurement starts when the specified Start HSFN is reached.
- Start at UE-ID:** The measurement starts when the specified Start UE-ID is detected for the first time.

Repetition mode

- Single Shot:** The measurement is stopped after a specific number of subframes (max. 20479).
- Continuous:** Continuous capturing of data until the measurement is explicitly stopped by the user.

Display mode

- Current:** Data rate and throughput of the current HSFN are displayed.
- Average** Average results are calculated over a specified number of subframes.
- Max / Min** Max/Min results are recorded over the whole measurement time.

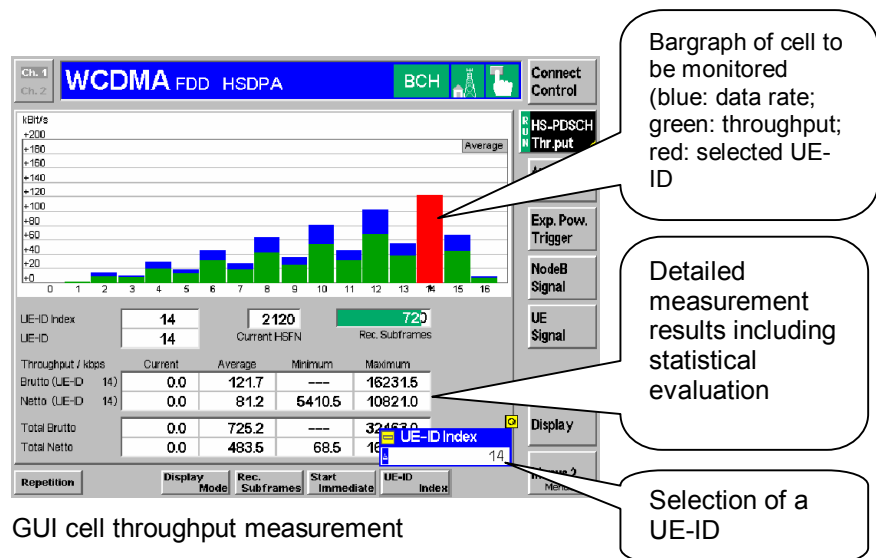

The bargraph shows a rough overview of all UEs to be monitored. Depending on the display mode, the bargraph shows current, average, minimum or maximum values. The present display mode is shown in the upper right corner of the screen. The different colors of the bars show the data rate and throughput. To show detailed measurement values, a UE-ID index can be selected. The selected UE-ID index is marked red in the bar graph and the corresponding UE-ID is displayed. The display mode and the UE-ID for detailed measurement results can be selected during the measurement as well as after the measurement is stopped.

8 HSDPA Uplink Generator

The UL generator function simulates one UE and activates an HSDPA uplink signal in addition to common physical and 3GPP reference measurement channel types. The high-speed dedicated physical control channel (HS-DPCCH) can be established with user-defined ACK/NACK and/or channel quality indicator (CQI) sequences.

Essential features:

- User-definable, continuously repeating sequence of up to 64 ACK/NACK/OFF events
- HSFN- or UE-ID-triggered activation of the ACK/NACK sequence
- User-definable ACK/NACK power ratio
- User-definable number of subframes between two consecutive ACK/NACKs
- HSFN-triggered activation of the CQI sequence
- User-definable, continuously repeating sequence of up to 64 CQI events
- User-definable number of subframes between two consecutive CQIs
- User-definable CQI power ratio

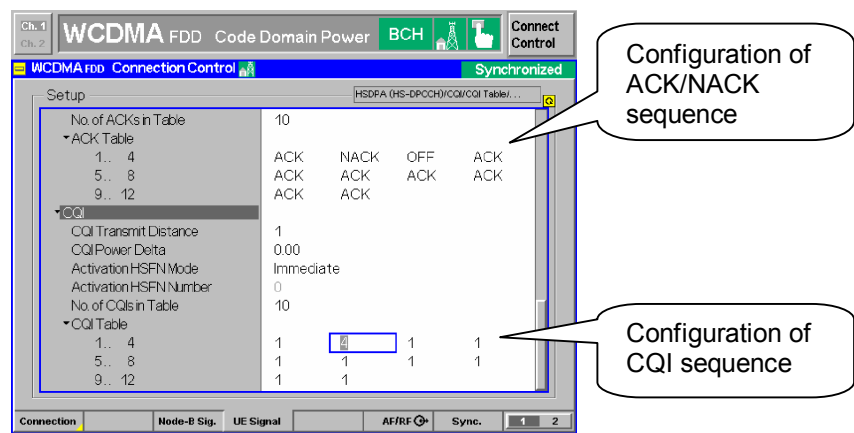

GUI HSDPA uplink generator configuration

9 HSDPA “Stimulate & Check” Testing

The “Stimulate & Check” test of the HSDPA signaling mode is the combination of synchronous HS-DPCCH stimulation (uplink) and HS-SCCH monitoring (downlink); the UE signal on the uplink is activated by the UE-ID trigger derived from HS-SCCH analysis on downlink. Every time a particular UE-ID is received, an element of the user-defined ACK/NACK sequence will be transmitted on the uplink. Node B’s reaction on the downlink can be checked simultaneously using the HS-SCCH monitoring function, which allows the time-critical behavior of MAC-HS to be tested dynamically.

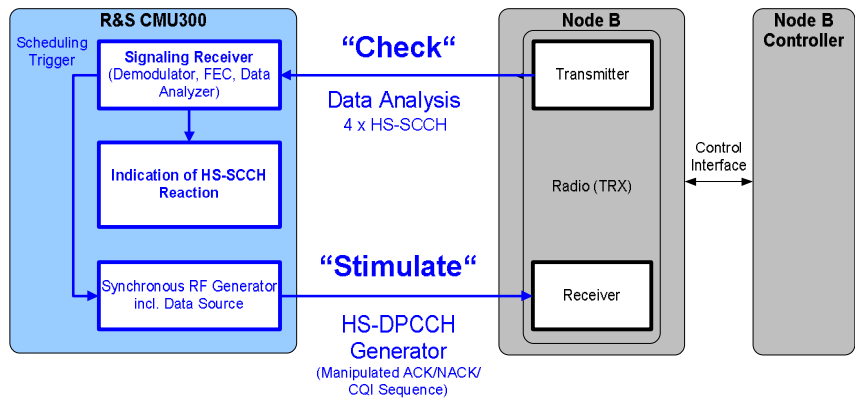

Principle of HSDPA “Stimulate & Check” testing

10 References

- [1] 3GPP TS 25.141 Technical Specification, 3rd Generation Partnership Project; Technical Specification Group Radio Access Network; Base Station (BS) conformance testing (FDD) (Release 5)

11 Abbreviations

ACLR	Adjacent Channel Leakage Ratio
AICH	Acquisition Indication Channel
BCH	Broadcast Channel
BER	Bit Error Ratio
BLER	Block Error Ratio
CDP	Code Domain Power
CPICH	Common Pilot Channel
CQI	Channel Quality Indicator
DBLER	Data Block Error Ratio
DL	Downlink
DPCH	Dedicated Physical Channel
EVM	Error Vector Magnitude
FDD	Frequency Division Duplex
HSDPA	High Speed Downlink Packet Access
HSFN	High Speed System Frame Number
HW	Hardware
HS-DPCCH	High Speed Dedicated Physical Control Channel
HS-DSCH	High Speed Downlink Shared Channel
HS-SCCH	High Speed Shared Control Channel
Node B	WCDMA Base Station
OBW	Occupied Bandwidth
PCDEP	Peak Code Domain Error Power
Pd	Probability of Detection of Preamble
PEP	Peak Envelope Power
Pfa	Probability of false Detection of Preamble
P-CCPCH	Primary Common Control Physical Channel
RACH	Random Access Channel
R99	Release 1999
RMC	Reference Measurement Channel
RX	Receiver
SEM	Spectrum Emission Mask
SFN	System Frame Number
SIB	System Information Block
SW	Software
TrCH	Transport Channel
TX	Transmitter

UL

Uplink

12 Ordering Information

TYPE	Stock No.	Designation
R&S® CMU300	1100.0008.03	UNIVERSAL RADIO COMMUNICATION TESTER FOR BTS TEST
R&S® CMU-K70	1157.4602.02	SW OPTION FOR CMU300: DTCH BER ANALYSIS (3GPP/FDD/DL)
R&S® CMU-K71	1157.4702.02	SW OPTION FOR CMU300: RACH TESTING (3GPP FDD)
R&S® CMU-K72	1200.7603.03	SW OPTION FOR CMU300: HSDPA STIMULATION, CMU-K78 AND CMU-K72 NECESS.
R&S® CMU-K73	1200.7703.03	SW OPTION FOR CMU300: HS-SCCH MONITOR and HSDPA THROUGHPUT MEASUREMENT, CMU-K78 NECESS.
R&S® CMU-K75	1150.3200.02	SW OPTION FOR CMU300: WCDMA TX TEST (3GPP/FDD/DL) CMU-U75 NECESSARY
R&S® CMU-K77	1150.4107.02	SW OPTION FOR CMU300: AWGN GENERATOR AND BER/BLER SIMUL. (3GPP/FDD/UL) CMU-K76 NECESS.
R&S® CMU-K78	1157.4802.02	SW OPTION FOR CMU300: BCH SYNCHRONIZATION AND MONITORING (3GPP FDD)
R&S® CMU-K79	1150.4407.02	SW OPTION FOR CMU300: HSDPA TX MEASUREMENTS (NON-SIGNALING, 3GPP/FDD/DL), CMU-K75 NECESS.
R&S® CMU-B78	1159.1800.02	HW OPTION FOR CMU300: LAYER1-BOARD FOR WCDMA DL RX AND UL TX

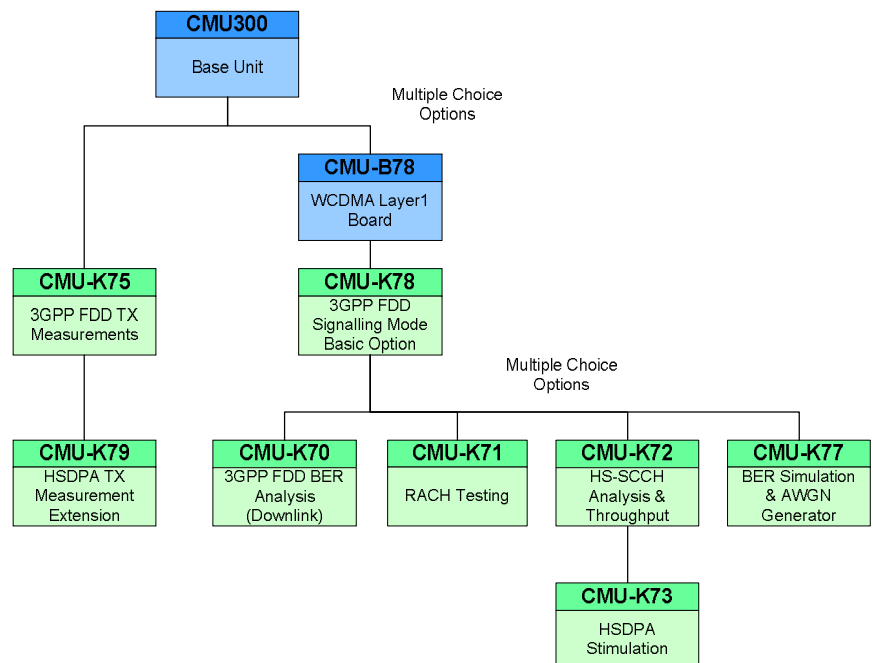

R&S CMU300 3GPP FDD Signalling Mode

Functionality		R&S CMU300 WCDMA Options									
		CMU-B78	CMU-K70	CMU-K71	CMU-K72	CMU-K73	CMU-K75	CMU-K76	CMU-K77	CMU-K78	CMU-K79
WCDMA / HSDPA TX parametric tests							√				√
WCDMA non-signalling mode	Uplink generator	√						√	o		
WCDMA/HSDPA signalling mode	BCH synchronization, BCH analysis and triggering	√								√	
	BER test includes uplink generator and downlink data analyzer	√	√						o	√	
	RACH preamble test	√		√						√	
	HS-SCCH monitor and HSDPA throughput measurement	√			√					√	
	HSDPA uplink stimulation	√			√	√			o	√	
	HSDPA "stimulate & check"	√			√	√			o	√	

√ mandatory option
o extended functionality

History

Version	File name	Editor	Comments
V1.0	1CM58_E.doc	R&S Gr	CMU300 SW version V3.65 R99 Signaling Mode
V2.0	1CM58_E_1.doc	R&S Gr	CMU300 SW version V3.82 HSDPA Signaling Mode added



ROHDE & SCHWARZ

ROHDE & SCHWARZ GmbH & Co. KG · Mühlhofstraße 15 · D-81671 München · Postfach 80 14 69 · D-81614 München · Tel
(089) 4129 -0 · Fax (089) 4129 - 13777 · Internet: <http://www.rohde-schwarz.com>

This application note may only be used subject to observance of the conditions of use set forth in the download area of the Rohde & Schwarz website.