



CDMA2000

- 3.4.2 Demodulation of F-FCH in Multipath Fading Channel
- 3.4.7 Demodulation of F-TCH in Multipath Fading Channel (FPC_MODE = '000')
- 3.4.8 Demodulation of F-TCH in Multipath Fading Channel (FPC_MODE = '010')
- 3.4.9 Demodulation of F-TCH in Multipath Fading Channel (FPC_MODE = '000', '001' and '010')
- 3.5.2 Single Tone Desensitization
- 3.5.3 Intermodulation Spurious Response Attenuation
- 3.5.4 Adjacent Channel Selectivity
- 3.5.5 Receiver Blocking Characteristics
- 3.6.1 Conducted RX Spurious Emissions
- 4.5.1 Conducted TX Spurious Emissions
- 4.5.3 Occupied Bandwidth

Rohde & Schwarz products: Universal Radio Communication Tester R&S[®]CMU200, Signal Analyzer R&S[®]FSQ, Spectrum Analyzers R&S[®]FSU, R&S[®]FSP and R&S[®]FSL, Signal Generators R&S[®]SMU200A, R&S[®]SMJ100A, R&S[®]SMIQ, R&S[®]SML and R&S[®]SMR, Baseband Generator R&S[®]AMU200A

Additional Tests on CDMA2000[®] Mobile Stations in Accordance with Standard TIA-98

Application Note 1MA86

Most of the tests specified in the standard TIA-98 that a CDMA2000[®] mobile station has to fulfill can be performed by the Universal Radio Communication Tester R&S[®]CMU200 without further assistance. Other tests, however, require additional instruments, for instance for generating interfering signals. Some tests of the standard TIA-98 need features that a tester optimized for production cannot offer, for example high dynamic spectrum analysis up to 12.75 GHz.

This Application Note shows how to perform these tests easily with the remote-control software CMUgo, using the R&S[®]CMU200 in combination with R&S[®]SMU, R&S[®]SMJ, R&S[®]SMIQ, or R&S[®]SML signal generators, and R&S[®]FSQ, R&S[®]FSU, R&S[®]FSP, or R&S[®]FSL spectrum analyzers.

New test items and sequences have therefore been included in the CMUgo software to remote-control the R&S[®]CMU200, as well as the signal generators and spectrum analyzers. They are presented in this Application Note.



Contents

1	Overview	3
2	CMUgo: Operating Principles.....	5
	System Requirements.....	6
	Installation of CMUgo.....	6
	Configuring the GPIB settings.....	6
	Measuring the path losses	8
3	Receiver Tests	9
	Receiver Tests under Static Conditions.....	9
	3.5.2: Single-Tone Desensitization	9
	3.5.3: Intermodulation Spurious Response Attenuation.....	20
	3.5.4: Adjacent Channel Selectivity.....	27
	3.5.5: Receiver Blocking Characteristics	33
	3.6.1: RX Conducted Spurious Emissions.....	42
	Receiver Tests in Multipath Fading Channel	47
	3.4.2, 3.4.7 - 3.4.9: Demodulating the Forward Channel.....	48
	Generic Test Item, Subtests, Sequences	52
	Test Procedure	53
4	Transmitter Tests	61
	4.5.1: TX Conducted Spurious Emissions	61
	4.5.3: Occupied Bandwidth	66
5	Summary.....	72
6	References.....	73
7	Ordering Information	73

The following abbreviations are used in this Application Note for Rohde & Schwarz test equipment:

- The Universal Radio Communication Tester R&S®CMU200 is referred to as the CMU.
- The Vector Signal Generator R&S®SMU200A is referred to as the SMU.
- The Vector Signal Generator R&S®SMJ100A is referred to as the SMJ.
- The Vector Signal Generator R&S®SMIQ is referred to as the SMIQ.
- The Signal Generator R&S®SML is referred to as the SML.
- The Signal Generator R&S®SMR is referred to as the SMR.
- The Signal Generator R&S®FSL is referred to as the FSL.
- The Spectrum Analyzer R&S®FSP is referred to as the FSP.
- The Spectrum Analyzer R&S®FSU is referred to as the FSU.
- The Signal Analyzer R&S®FSQ is referred to as the FSQ.

The R&S logo, Rohde & Schwarz, and R&S are registered trademarks of Rohde & Schwarz GmbH & Co. KG and its subsidiaries.

CDMA2000® is a registered trademark of the Telecommunications Industry Association (TIA -USA).

1 Overview

Most of the tests specified in the standard TIA-98 that a CDMA2000® mobile station (MS) has to fulfill can be performed by the Universal Radio Communication Tester CMU200 without further assistance. Other tests, however, require additional instruments, for instance for generating interfering signals. Some tests of the standard TIA-98 need features that a tester optimized for production cannot offer, for example high dynamic spectrum analysis up to 12.75 GHz.

This Application Note shows how to perform these tests easily with the remote-control software CMUgo, using the CMU200 in combination with SMU, SMJ, SMIQ, or SML signal generators, and FSQ, FSU, FSP, or FSL spectrum analyzers.

New test items and sequences have therefore been included in the CMUgo software to remote-control the CMU200 as well as the signal generators and spectrum analyzers. These predefined settings are an integral part of CMUgo from version 1.70

This expands the list of the CDMA2000® MS measurements already implemented in the CMU200 firmware by the following tests (the leading number is the corresponding section number of the test in the standard TIA-98):

Receiver tests under static conditions:

- 3.5.2 Single-Tone Desensitization
- 3.5.3 Intermodulation Spurious Response Attenuation
- 3.5.4 Adjacent Channel Selectivity
- 3.5.5 Receiver Blocking Characteristics
- 3.6.1 Conducted RX Spurious Emissions

Receiver tests in multipath fading channel:

- 3.4.2 Demodulation of Forward Fundamental Channel in Multipath Fading Channel
- 3.4.7 Demodulation of Forward Traffic Channel in Multipath Fading Channel with Closed Loop Power Control (FPC_Mode = '000')
- 3.4.8 Demodulation of Forward Traffic Channel in Multipath Fading Channel with Closed Loop Power Control (FPC_Mode = '010')
- 3.4.9 Demodulation of Forward Traffic Channel in Multipath Fading Channel with Outer Loop Power Control and Closed Loop Power Control (FPC_Mode = '000', '001', and '010')

Transmitter tests:

- 4.5.1 Conducted TX Spurious Emissions
- 4.5.3 Occupied Bandwidth

Additional Tests on CDMA2000 Mobile Stations

For each of the tests mentioned above, this Application Note gives you a short overview of the test itself, a recommended hardware setup, predefined test sequences, and step-by-step instructions on how to perform this test using the CMUgo software.

Measurement results obtained with these predefined sequences complete the presentation of each test.

2 CMUgo: Operating Principles

CMUgo is a software tool for running remote-control tests using the CMU200 and additional instruments.

CMUgo provides a large number of essential test items of a measurement, such as *CDMA 2000 Single-Tone Desensitization*, *CDMA 2000 Adjacent Channel Selection*, *CDMA 2000 Blocking Test*, and so on. To set up a complete test, you need – in addition – some more general test items: *Basic Initializing*, *Call Setup*, *Call Release*, and *Test End* (to display a summary result).

Use these test items as building blocks to create your own test sequences.

For the seven tests mentioned above, there are predefined test sequences included in CMUgo from version 1.70. They are examples referring to band class 1 (BC 1), but can be easily switched to other band classes as well.

With this support, your operating procedure will always be as follows:

- Load a predefined test sequence.
- Adapt the parameters to your application and enter the path losses of your test setup (see section below).
- Save your test sequence for later use.
- Run the test.

All predefined sequences include in their name the section number of the test in the standard TIA-98. For example, for the *Single-Tone Desensitization* test described in section 3.5.2 in TIA-98 load sequence *CDMA2000_3.5.2.seq*.

It is presumed that you are already familiar with the CMU200 and CMUgo.

Otherwise first read the manual in the file CMUgo.pdf, which is extracted during installation to a folder of your choice. It describes the menus, the entries and the controls, and provides examples. We encourage you to learn as you go.

- Familiarize yourself with the CMUgo software.

Note: Read 3.5.2: *Single-Tone Desensitization* at first, since details on the complete measurement are given there, which are not repeated in the description of the other tests.

System Requirements

To ensure proper operation of CMUgo, your computer should fulfill the following minimum requirements:

Platform: Windows 98 / ME / 2000 / XP

Processor: Pentium 300

RAM: 64 Mbytes

Display: SVGA 800x600 pixels

(For more convenient use of CMUgo, particularly the presentation of measurement reports, the video graphics card must have a higher resolution.)

Hard-disk storage: 50 Mbytes

Peripherals: Mouse

National Instruments GPIB bus card

To make full use of CMUgo's capabilities, the CMU200 firmware version must be 3.80 or later.

Installation of CMUgo

Application Note 1MA86 consists of two parts:

- The CMUgo software (file CMUgo.zip)
- This document (1MA86_xE.pdf)

Download it from <http://www.rohde-schwarz.com/appnote/1MA86>

To get the installation files:

Unzip CMUgo.zip. One of the extracted files is setup.exe.

- Run setup.exe.
- Follow the instructions of the installer dialog.

Configuring the GPIB settings

CMUgo is used here as a tool to remote-control the CMU200 and other instruments via the GPIB bus. All devices should be set to different IEEE addresses, and have to be connected via the GPIB bus to your controller where CMUgo is running.

(To keep the setup figures simple, GPIB interfacing has been omitted in those figures on the following pages.)

- Run CMUgo.
- Click *Configuration*

The port for remote control of the CMU200 can be configured at *Remote Port*. In addition, CMUgo can control up to ten additional *Auxiliary GPIB Ports*:

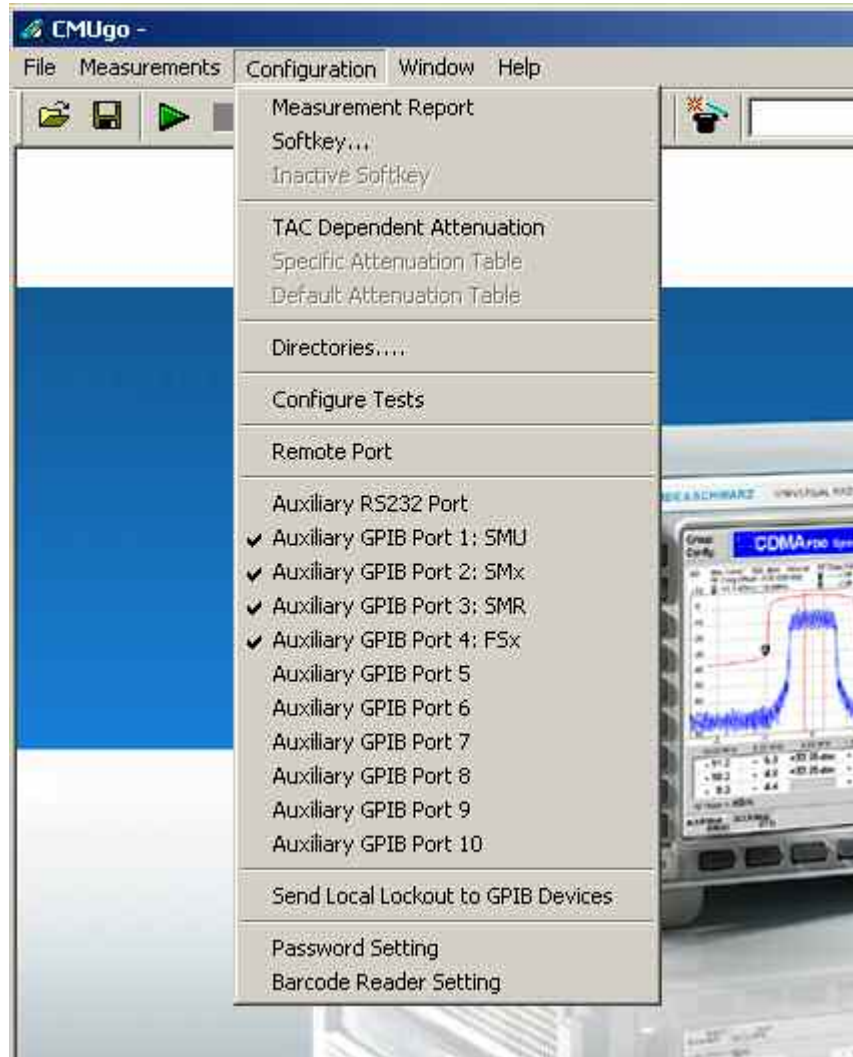

Fig. 1_3: GPIB configuration for up to ten additional instruments

- Double-click one of the auxiliary GPIB ports to make a device known to CMUgo.

The configuration window for this port opens (see Fig. 1_4 on page 8).

- Enter a device name you wish to use.
Always use the same device names and spellings that you use later in the test items. We recommend '**FSx**' for any analyzer (FSQ, FSU, FSP or FSL), '**SMx**' for any CW generator (SMU, SMJ, SMIQ, SMR or SML), '**SMR**' for SMR, and '**SMU**' for SMU exclusively.
- Enter the GPIB address.
- Enable port (do not omit this step!).
- Repeat this procedure for the other devices.

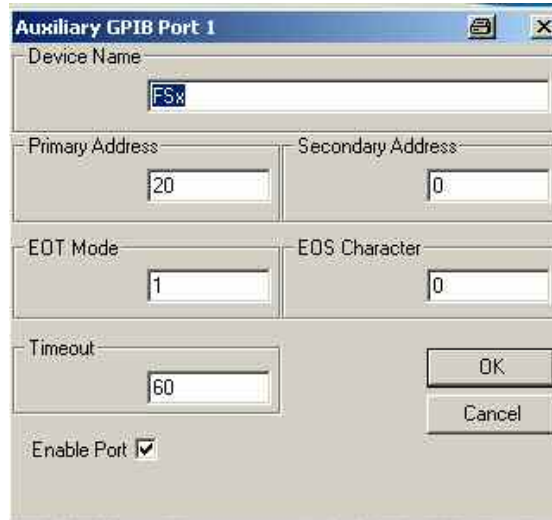

Fig. 1_4: Configuration of *Auxiliary GPIB Port*, *Enable Port* checkbox.

Measuring the path losses

For each test you will find a recommended hardware setup in this Application Note. Even if you work with the same components, your setup will have its own characteristic that depends, for example, on the lengths and types of your cables.

Before running any test, measure the actual path losses of your hardware setup. Use the same frequencies that are used later in the test. Enter the measured values as *Input* or *Output Attenuation* when you edit a test sequence. The losses will thus automatically be compensated by the software.

We recommend the Rohde & Schwarz application program FreRes as a helpful tool for measuring frequency response. FreRes is part of Application Note 1MA09, which you can download free of charge at

<http://www.rohde-schwarz.com/appnote/1MA09>

Note: For measurements below 10 MHz, set the analyzer to input DC.

3 Receiver Tests

Receiver tests can be divided into two groups: the first group uses a static forward channel. The second group simulates a multipath fading channel that varies over time. Because the receiver tests under static conditions are less complex, they are described at first.

Receiver Tests under Static Conditions

3.5.2: Single-Tone Desensitization

The single-tone desensitization is a measure of a receiver's ability to receive a CDMA signal at its assigned frequency in the presence of a single tone spaced at given frequency offsets from the center frequency of the assigned CDMA channel.

A receiver's single-tone desensitization performance is measured by the frame error rate (FER).

The purpose of test 3.5.2 is to verify that the FER of the mobile station does not exceed 1 % with 95 % confidence level under these conditions.

This test shall be performed for each band class (BC) the mobile station supports, except band class 6.

Recommended test setup:

Fig. 3.5.2_1 (on page 9) shows the test setup for single-tone desensitization tests.

The RF ports of CMU200 Radio Communication Tester and the mobile station under test are connected by means of a 6 dB resistive combiner. During the test, a call is set up to the mobile station (MS) and a connection is established by CMU using this path. In addition, a signal generator is coupled in to provide the single-tone interferer. The resistive combiner ensures a flat frequency response. The 10 dB attenuator in the generator path decouples the instrument and reduces the CDMA signals at the generator input to a harmless level.

Both CMU and signal generator are remote-controlled by CMUgo to run the test automatically.

Instruments and accessories:

- CMU200, SMU or SMJ or SMIQ or SML
- Resistive combiner, frequency response depending on the band class (recommended: Weinschel 1515-1, DC to 12.75 GHz)

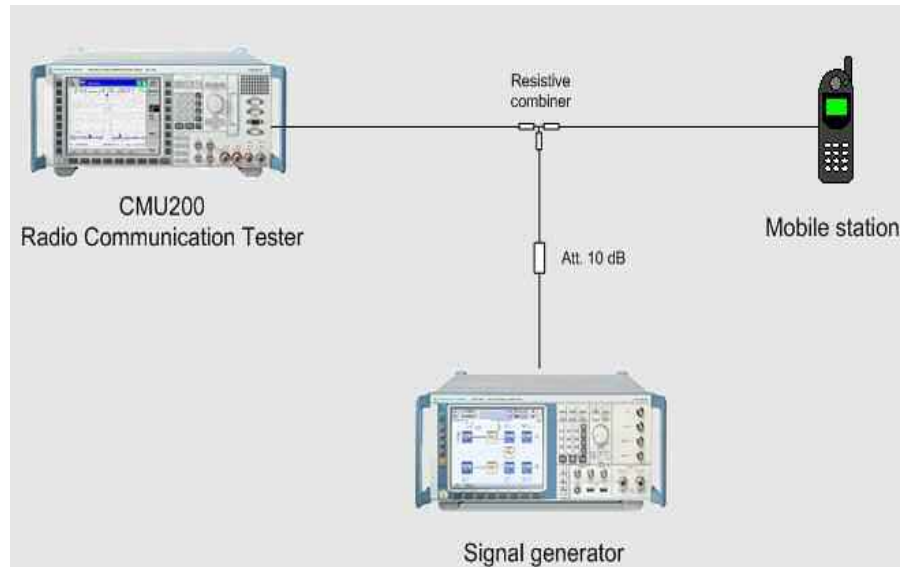

Fig. 3.5.2_1: Test setup for single tone desensitization test

Path loss compensation:

(see previous section)

- Measure the path loss between the MS and the CMU200
- Measure the path loss between the MS and the signal generator

Test procedure:

- 1) Connect instruments and mobile station as shown in Fig. 3.5.2_1.
- 2) Run CMUgo, and then click *Configuration, Configure Tests*.

The *Configure Test* window opens.

- 3) Click *Load Sequence*, and select *CDMA2000_3.5.2.seq*.

The *Configure Test* window looks like Fig. 3.5.2_2 (on page 11): The left-hand column contains all available test items, and the right column shows which test items have been selected to build the sequence for test 3.5.2.

In general every CMUgo test sequence starts with a *Basic Initializing* of the CMU. It always ends with the item *Test End*, which provides a summary result. Each CDMA2000[®] MS test needs a call connection, which is established by the test item *CDMA 2000 Call Setup* and released by item *CDMA 2000 Call Release*.

The essential items for test 3.5.2 are therefore the test items between *Call Setup* and *Call Release*. With sequence *CDMA2000_3.5.2.seq*, four tests for spreading rate 1 (SR1) are provided as listed in the standard TIA-98.

In addition, CMUgo contains bitmaps to show the hardware setup. The item *Show Hint* in the sequence above displays them as wallpaper until the measurement result is completely available. You can remove this item if you don't need it.

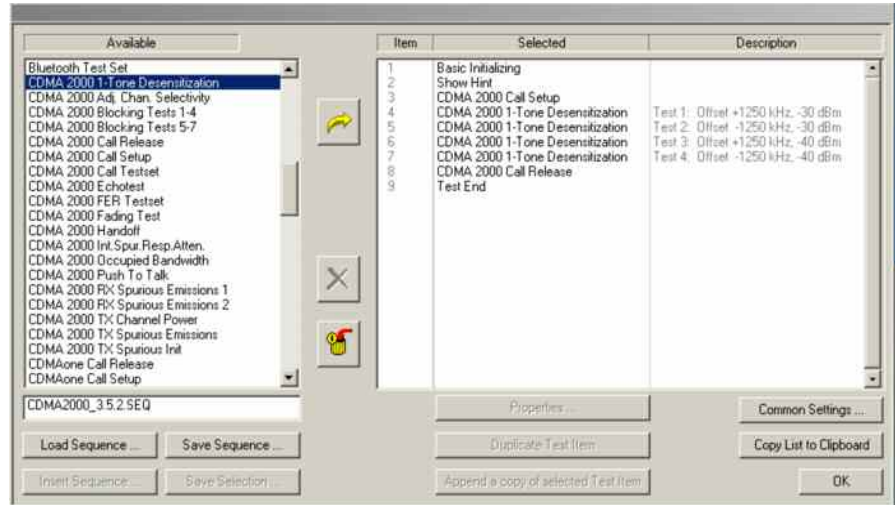

Fig. 3.5.2_2: *Configure Test* window. Available and selected test items (test sequence) for single-tone desensitization test.

Test items have to be configured before a test runs. Double-click a test item to open its configuration window.

Configure test item *Basic Initializing*:

- 1) Double-click the test item *Basic Initializing*. The configuration window opens (see Fig. 3.5.2_3). It shows which function groups could be available inside the CMU200.
- 2) Always enable the function group *RF*.

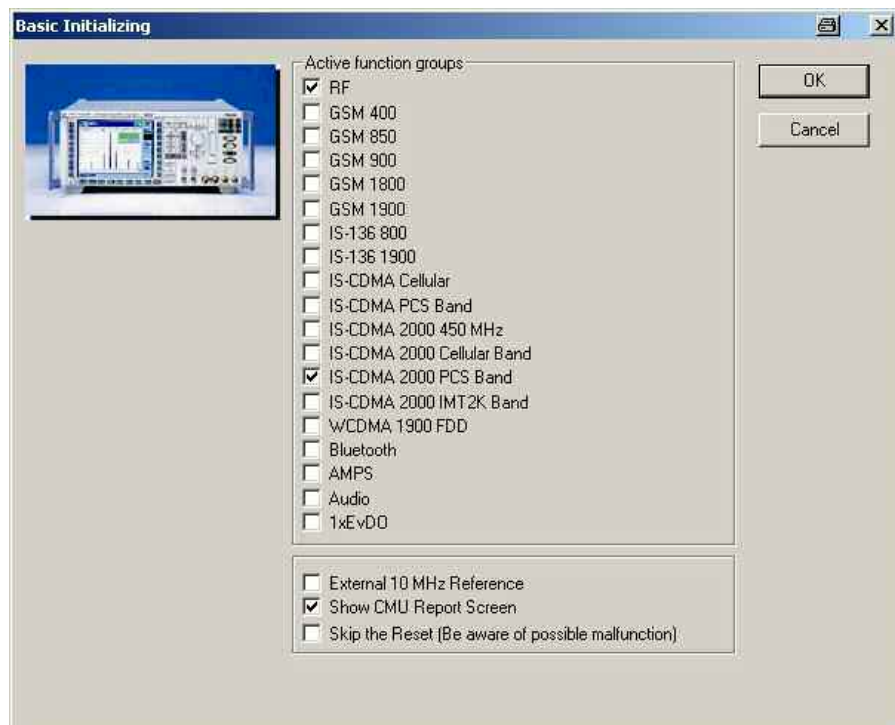

Fig. 3.5.2_3: Available function groups inside CMU200.

Additional Tests on CDMA2000 Mobile Stations

For any given band class of your device under test, table 3.5.2_4 tells you which function group to enable:

BC0, BC2, BC3, BC7, BC9, BC10	IS-CDMA2000 Cellular Band
BC1, BC4, BC8	IS-CDMA2000 PCS Band
BC5	IS-CDMA2000 450 MHz
BC6	IS-CDMA2000 IMT2K Band

Table 3.5.2_4: Band classes and CMU function groups.

- 3) Select the correct function group for your application.

Note: If you enable *Show CMU Report Screen*, the CMU monitors all GPIB commands from and to your remote controller. Otherwise the CMU screen will be blank.

- 4) Click OK.

You are back in the *Configure Test* window:

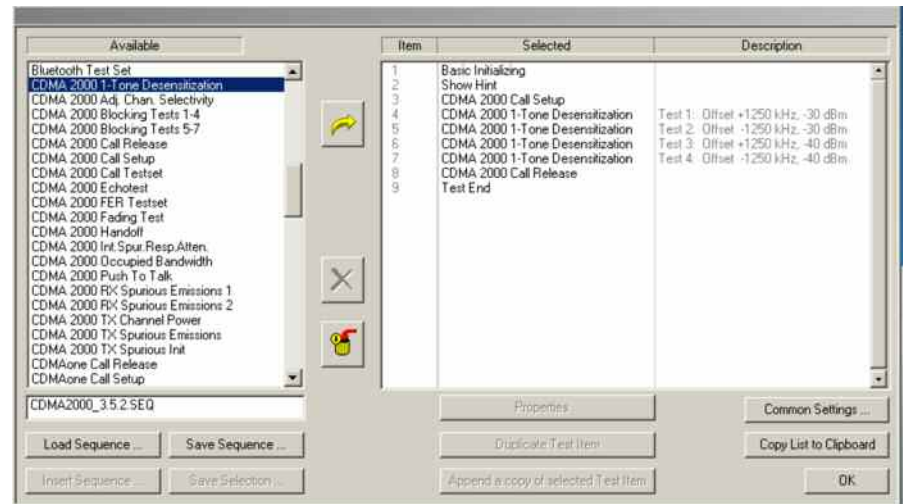

Fig. 3.5.2_5: *Configure Test* window

Configure test item *CDMA 2000 Call Setup*:

- 1) Double-click *CDMA 2000 Call Setup* in the list of the selected test items.

The window *Call Setup Configuration* opens (see Fig. 3.5.2_6 on page 12).

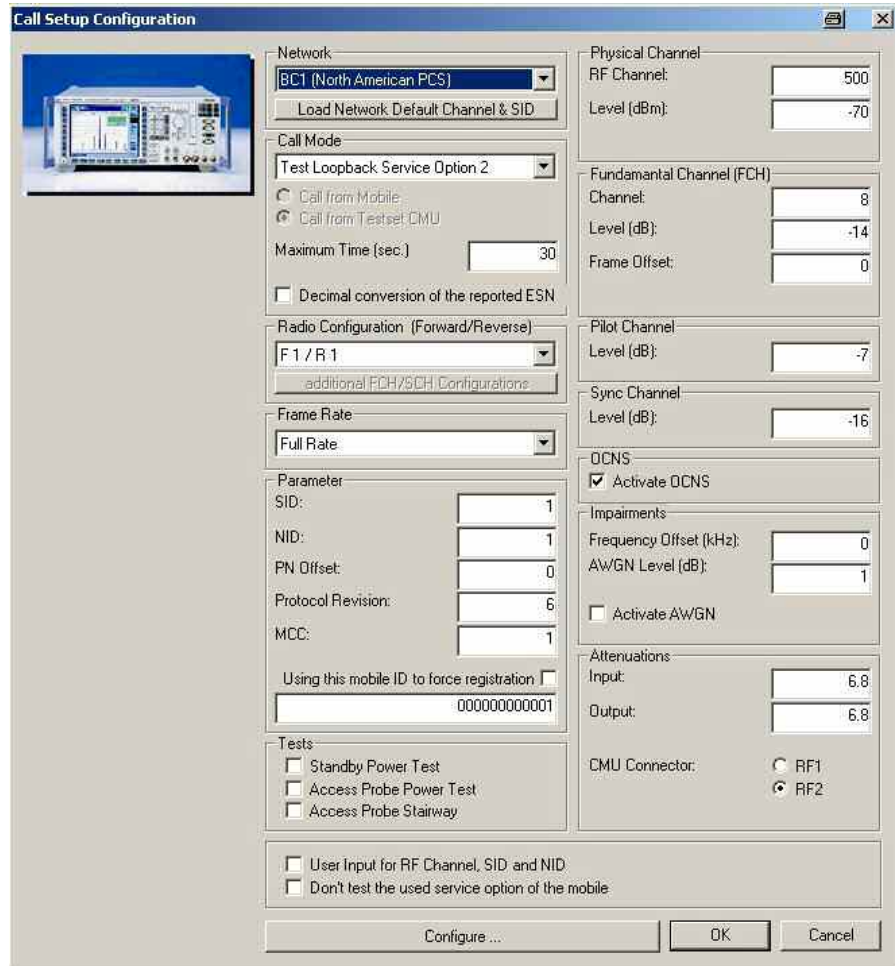

Fig. 3.5.2_6: Call setup configuration for CDMA2000[®] MS tests.

- 2) Select the *Network* corresponding to the band class (BC) of your mobile station.
- 3) Depending on the *Test Mode* select one *Call Mode* from the service options supported by both the CMU and your mobile station (see tables 3.5.2_7a, b):

Fundamental Channel			
Test Mode	RC of Forward Traffic Channel	RC of Reverse Traffic Channel	Call Mode (Service Option)
Test Mode 1	1	1	SO2 / SO55
Test Mode 2	2	2	SO9 / SO55
Test Mode 3	3	3	SO2 / SO55 / SO32
Test Mode 4	4	3	SO2 / SO55 / SO32
Test Mode 5	5	4	SO9 / SO55 / SO32

Table 3.5.2_7a: Test Modes, Radio Configurations and Call Modes on Fundamental Channel.

Additional Tests on CDMA2000 Mobile Stations

Supplemental Channel			
Test Mode	RC of Forward Traffic Channel	RC of Reverse Traffic Channel	Call Mode (Service Option)
Test Mode 3	3	3	SO32
Test Mode 4	4	3	SO32
Test Mode 5	5	4	SO32

Table 3.5.2_7b: Test Modes, Radio Configurations and Call Modes on Supplemental Channel.

Notes: Dedicated Control Channel Test Modes are currently not supported by CMU200.

Supplemental Code Channel Test Mode 1 / 2 not supported by CMU200.

SO2: Loopback Service Option 2

SO9: Loopback Service Option 9

SO55: Loopback Service Option 55

SO32: Test Data Service Option

- 4) Select your *Radio Configuration (Forward / Reverse)* combination.
- 5) Enter a channel number for the call setup at *Physical RF Channel*.
- 6) Enter the path loss you measured between the MS and the CMU200 as *Input Attenuation* and *Output Attenuation*.
- 7) Make sure that OCNC is activated.

You may modify the other parameters if necessary.

- 8) Click *OK*.

You are back in the *Configure Test* window:

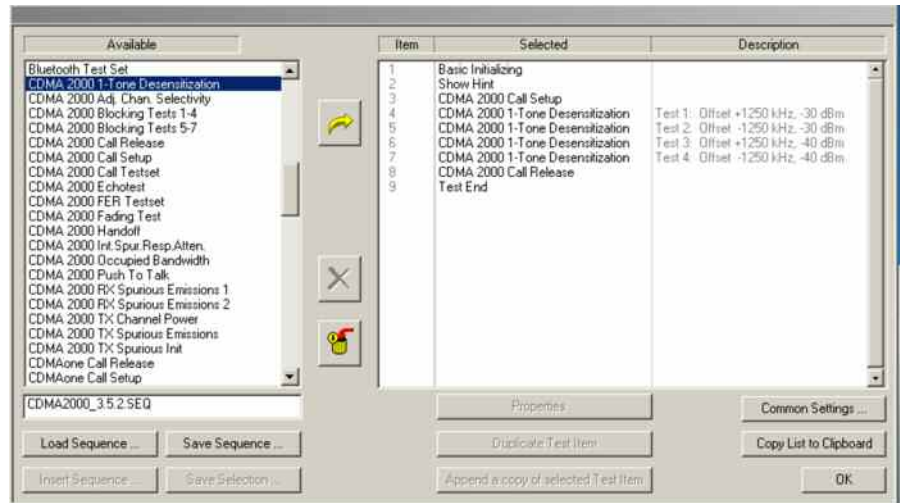

Fig. 3.5.2_8: Configure Test window

Configure test items **CDMA 2000 1-Tone Desensitization**:

- 1) Double-click **CDMA 2000 1-Tone Desensitization** (e.g. Item 4) in the list of the selected test items.

The window **FER Test Configuration** appears (see Fig. 3.5.2_8 on page 15). It provides parameter entry fields for one interfering generator (**SMx Signal**).

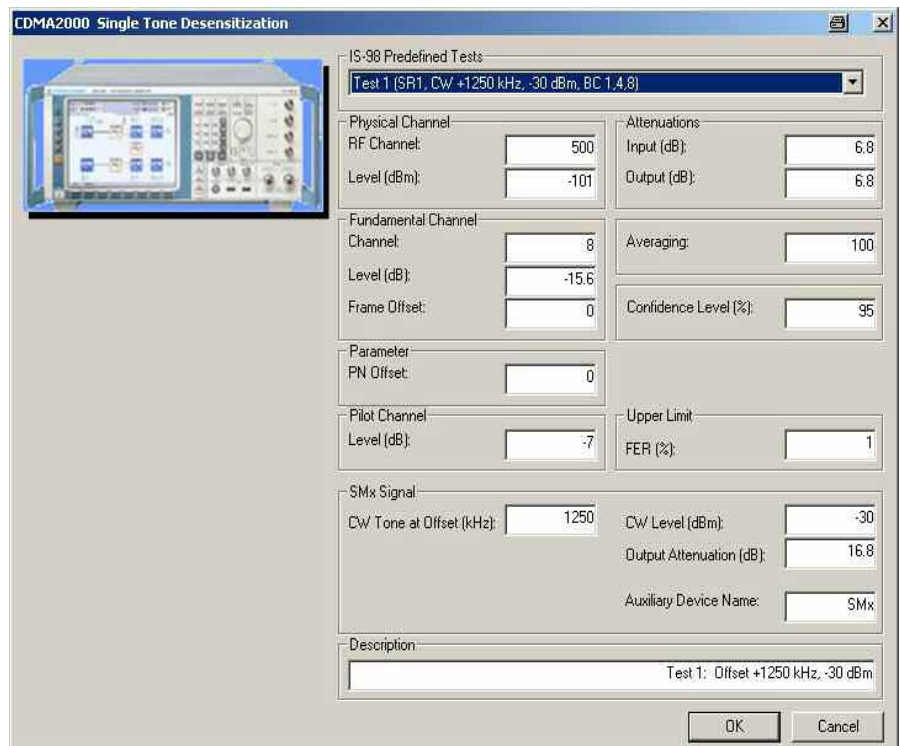

Fig. 3.5.2_9: Setup for CDMA2000® single tone desensitization (Test 1)

Additional Tests on CDMA2000 Mobile Stations

Opening the pull-down list *IS-98 Predefined Tests* gives you an overview of the available tests (see Fig. 3.5.2_9):

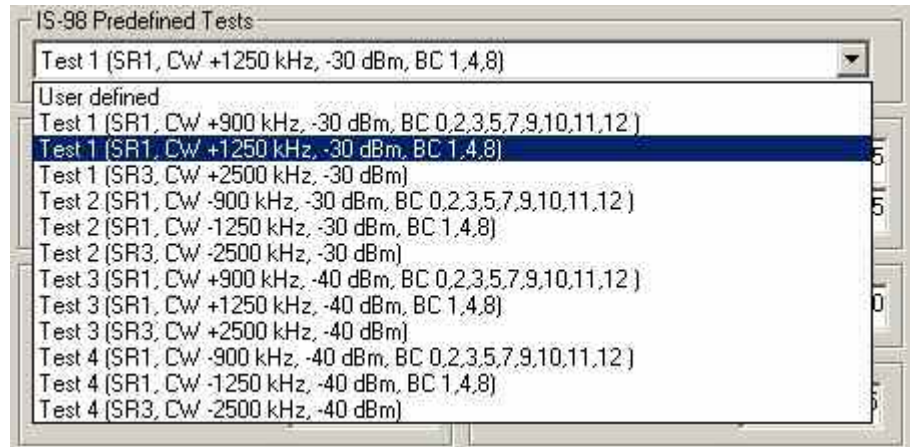

Fig. 3.5.2_10: Predefined tests for CDMA2000[®] single tone desensitization

Each of these selections comes with a full set of parameters in accordance with the standard TIA-98. These predefined parameters are all CMU and interferer *Levels*, the CW interferer frequency *Offset*, the *FER* limit, the *Averaging* count, and the *Confidence Level*.

- 2) Select your *Predefined Test* in accordance with the band class of your MS.

If you modify one of the parameters mentioned above, the selection automatically changes to *User defined*. If all parameters match the standard values again, the specific test will be indicated again.

- 3) Modify these parameters if necessary.

Listed below are some of the remaining parameters:

- 1) Enter a channel number at *Physical RF Channel*.
- 2) Enter the path loss you measured between the MS and the CMU200 as *Input* and *Output Attenuations*.
- 3) Enter the path loss you measured between the MS and the signal generator as *Output Attenuation* in the SMx field.
- 4) Enter as *Auxiliary Device Name* the name you specified for the generator's GPIB configuration (see section *Configuring the GPIB settings* on page 6).
- 5) Add a comment if you like.
- 6) Click *OK*.

You are back in the *Configure Test* window (Fig. 3.5.2_2).

- 7) Configure another item. If necessary, create your own sequence.

You may want to store your sequence. Use the button *Save Sequence* in the *Configure Test* window (see Fig. 3.5.2_2).

- 8) Finally click *OK* (in the *Configure Test* window).

This completes the measurement setup.

To start the measurement:

- Click the start icon in the menu bar of CMUgo (see Fig. 3.5.2_11).

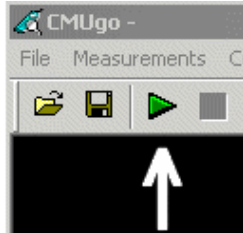

Fig. 3.5.2_11: Start icon in the menu bar of CMUgo

To stop a running measurement:

- Click the stop icon in the menu bar of CMUgo (see Fig. 3.5.2_12 on page 17).

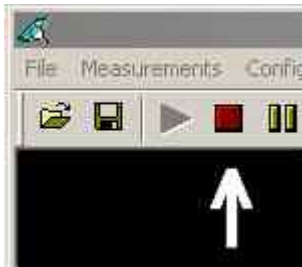

Fig. 3.5.2_12: Stop icon in the menu bar of CMUgo

Test description and measurement report:

Once you have clicked the start icon,

- the hardware setup is displayed as wallpaper, if the item *Show Hint* is present
- otherwise a temporary *Measurement Report* window is displayed.

To optimize the speed, these windows are not updated before the last measurement of the last test item has been finished.

The temporary *Measurement Report* window already shows the names of the tests and the test conditions. However, as long as the tests are running, all test items are indicated as *not performed*.

Additional Tests on CDMA2000 Mobile Stations

When the basic initialization is completed, a pop-up menu instructs you to *Switch on the Mobile*. Ignore this message if it is already powered up. After the individual response time of the MS, the CMU200 automatically registers the mobile station and sets up a call connection. The pop-up menu disappears when the call is established.

With the predefined sequence *CDMA2000_3.5.2.seq*, the following measurements are subsequently run:

Test 1: The total power of the CMU is set to -101 dB, and Pilot and Traffic power are set to -7 dB and -15.6 dB respectively. The interferer level is set to -30 dBm. The path losses you entered are compensated automatically. A first FER measurement is performed with an interferer frequency offset of $+2500$ kHz. The result is stored inside CMUgo.

Test 2: The test is repeated with the same levels but with an interferer offset of -2500 kHz. The result is stored inside CMUgo.

Test 3: The test is repeated with an interferer level of -40 dBm and an interferer offset of $+2500$ kHz. The result is stored inside CMUgo.

Test 4: The test is repeated with an interferer level of -40 dBm and an interferer offset of -2500 kHz. The result is stored inside CMUgo.

During the test, the currently executed test item and test step are indicated on the bottom bar of the *Measurement Report* window. (The test step is an internal count within each test item.)

Once all test steps have been completed, the hardware setup display is replaced by the *Measurement Report*, or the temporary *Measurement Report* window is updated. For *Single-Tone Desensitization*, a display similar to Fig. 3.5.2_12 appears.

Additional Tests on CDMA2000 Mobile Stations

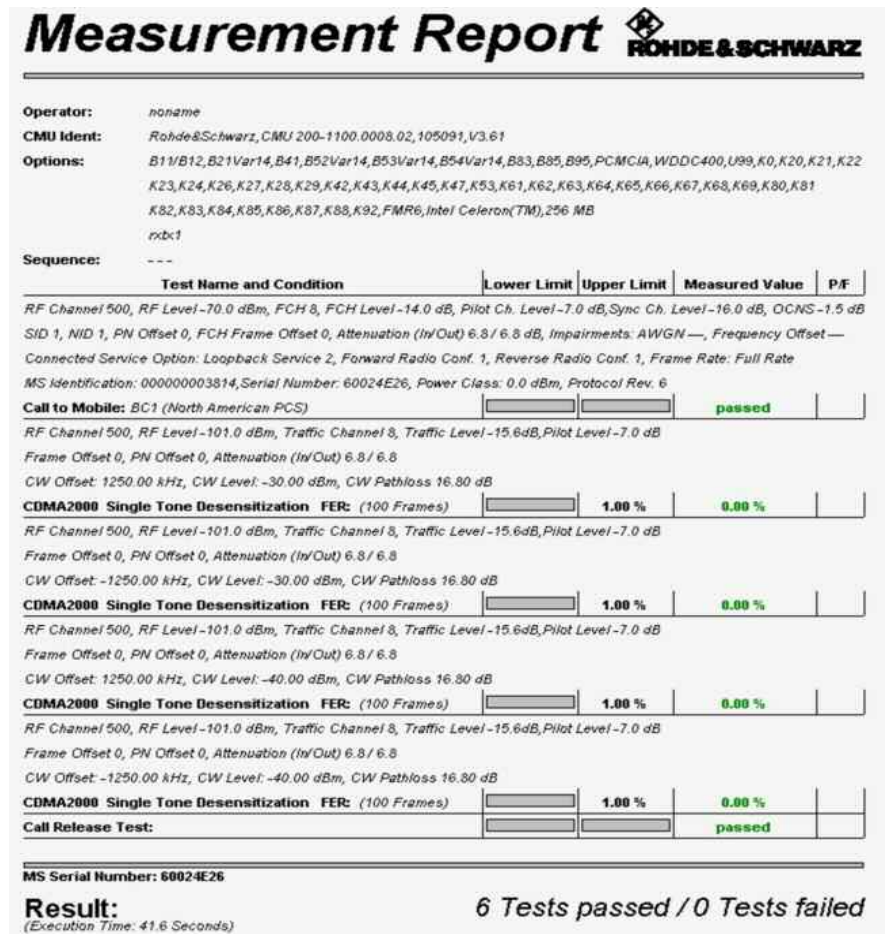

Fig. 3.5.2_13: Test result for single tone desensitization (BC1)

Measurement values that are below the limits are displayed in green; those which exceed the limits are displayed in red. In addition, the right-hand column (P/F, for Pass/Fail) indicates whether a test was passed or failed.

Note: *Call to Mobile* and *Call Release* are treated like the other test items. They increase the number of tests by two as tests without limits.

To repeat a test sequence, click the start button again (Fig. 3.5.2_11).

If your mobile station supports more than one band class, change the configurations accordingly and start the test sequence again.

3.5.3: Intermodulation Spurious Response Attenuation

The intermodulation spurious response attenuation is a measure of a receiver's ability to receive a CDMA signal at its assigned channel frequency in the presence of two interfering CW tones. These tones are separated from the assigned channel frequency and from each other such that the third order mixing of the two interfering CW tones can produce an interfering signal in the band of the desired CDMA signal.

The receiver performance is measured by the frame error rate (FER).

The purpose of test 3.5.3 is to verify that the FER of the mobile station does not exceed 1 % with 95 % confidence level under these conditions.

This test shall be performed for each band class the mobile station supports.

Recommended test setup:

Fig. 3.5.3_1 shows the test setup for intermodulation spurious response attenuation.

The RF ports of the Radio Communication Tester CMU200 and the mobile station under test are connected by means of a hybrid combiner. During the test, a call is set up to the mobile station and a connection is established by the CMU using this path. In addition two interfering signals are fed in from two generators. Hybrid combiners are used for this test because their isolation is better than that of resistive combiners. The hybrids decouple the instruments and make sure that the interferer signals at the CMU RF port are sufficiently low. Thus no additional mixing products can emerge due to non-linear elements inside the CMU. The 10 dB attenuator in the generator's path reduces the CDMA signals at the generator inputs to a harmless level.

The CMU and signal generators are remote-controlled by CMUgo to run the test automatically.

Instruments and accessories:

- CMU200, SMU or SMJ or SMIQ or SML
- Hybrid combiners, frequency response depending on the band class (recommended for BC 1: Minicircuits ZFSC-2-2500)

Path loss compensation:

(see previous section)

- Measure the path loss between the MS and the CMU200
- Measure the path losses between the MS and each signal generator

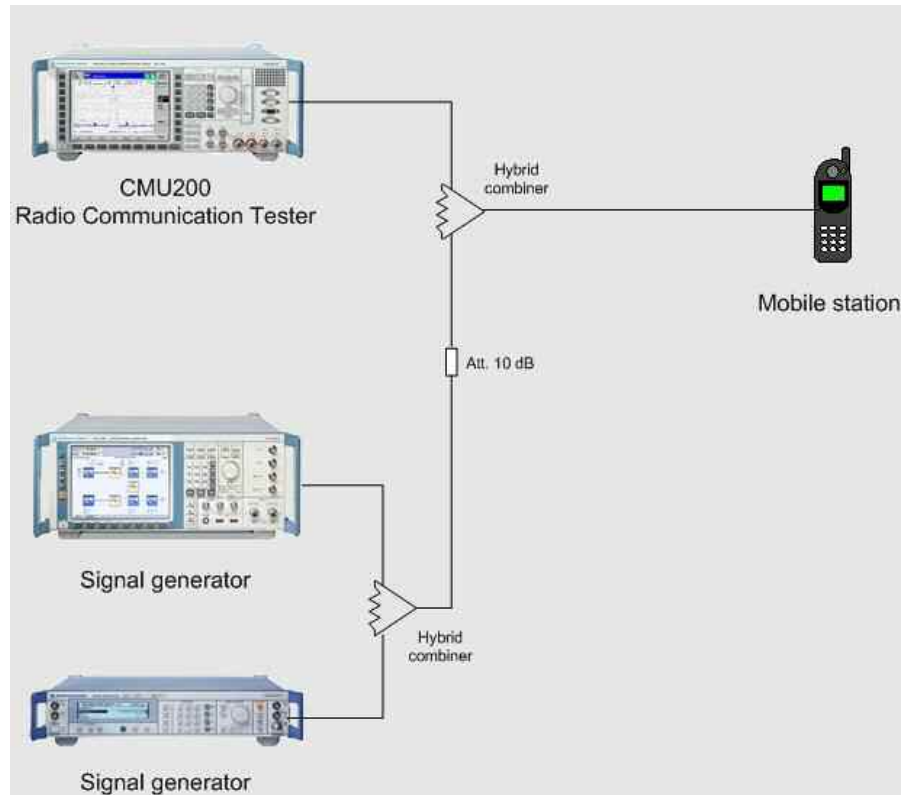

Fig. 3.5.3_1: Test setup for intermodulation spurious response attenuation.

Test procedure:

- 1) Connect instruments and mobile station as shown in Fig. 3.5.3_1.
- 2) Run CMUgo, and then click *Configuration, Configure Tests*.

The *Configure Test* window opens.

- 3) Click *Load Sequence*, and select *CDMA2000_3.5.3.seq*.

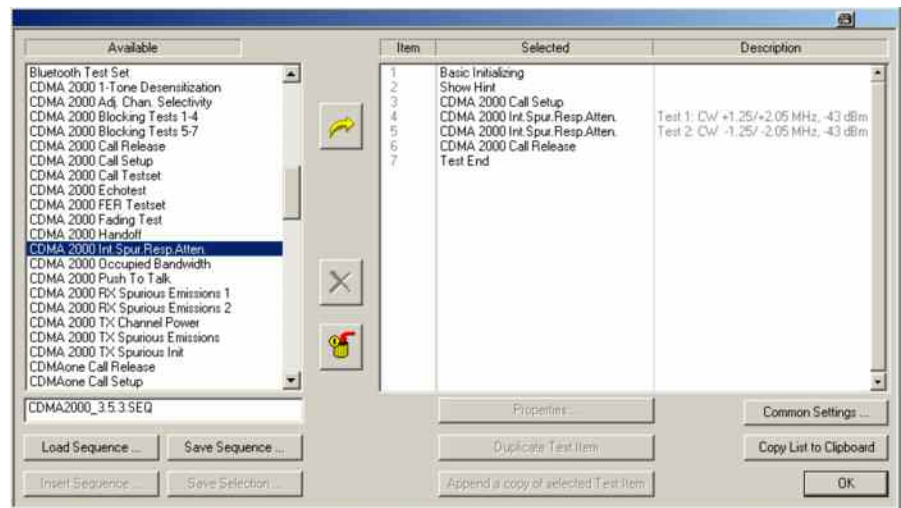

Fig. 3.5.3_2: Available and selected test items (test sequence) for intermodulation spurious response attenuation.

At first check Basic Initializing

Check whether the correct function group inside the CMU is activated (see table 3.5.2_4 at page 10).

Configure test item *CDMA 2000 Call Setup*:

- 1) Double-click *CDMA 2000 Call Setup* in the list of the selected test items.

The window *Call Setup Configuration* opens.

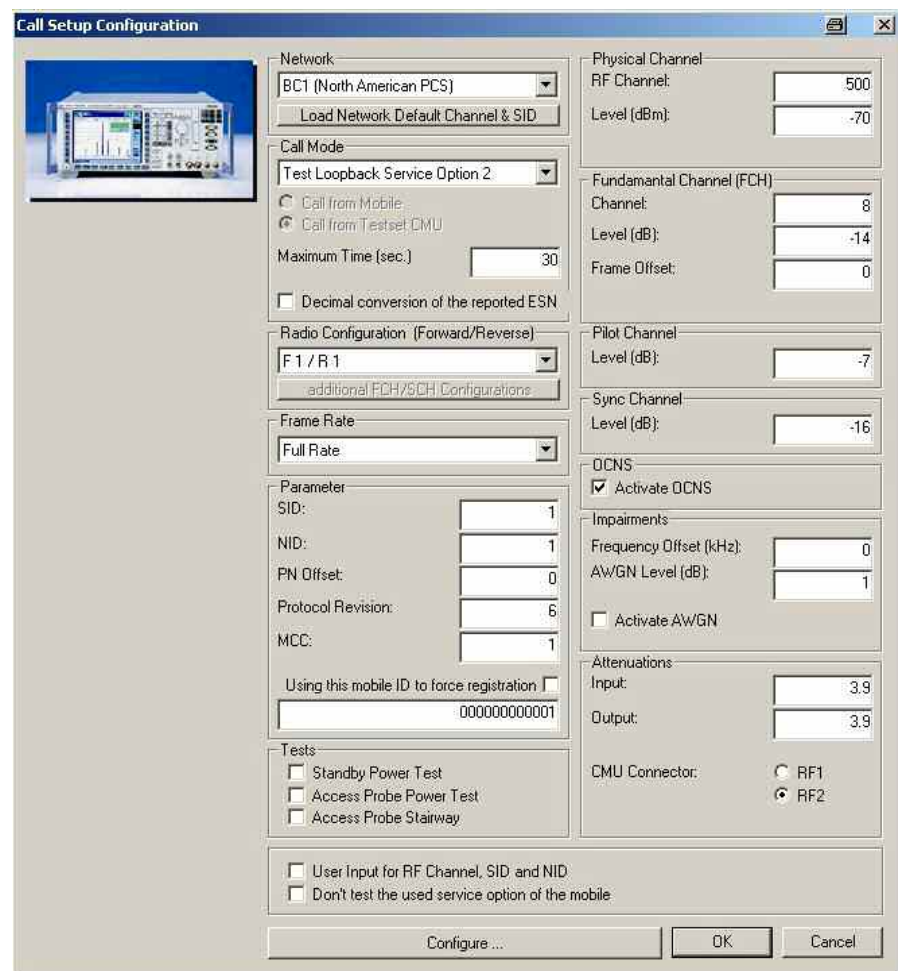

Fig. 3.5.3_3: Call setup configuration for CDMA2000[®] MS tests.

- 2) Select the *Network* corresponding to the band class (BC) of your mobile station..
- 3) Depending on the radio configuration (RC) your mobile station supports, select one *Call Mode* from the Service options supported by both the CMU and your mobile station (see table 3.5.3_4):

Additional Tests on CDMA2000 Mobile Stations

Radio Configuration	Call Modes
RC 1, 2, 3, 4, or 5	Service Option 2, or 55 (Fund. Test Mode 1) Service Option 55, or 32 (Fund. Test Mode 3) Service Option 32 (Ded. Control Test Mode 3)

Table 3.5.3_4: Radio configuration and call modes.

Depending on the *Call Mode* you selected, the configuration window provides a set of *Radio Configuration* combinations.

- 4) Select your *Radio Configuration (Forward / Reverse)* combination.
- 5) Enter a channel number for the call setup at *Physical RF Channel*.
- 6) Enter the path loss you measured between the MS and the CMU200 as *Input Attenuation* and *Output Attenuation*.
- 7) Make sure that OCNS is activated.

You may modify the other parameters if necessary.

- 8) Click *OK*.

You are back in the *Configure Test* window (Fig. 3.5.3_2):

Configure test items *CDMA 2000 Int. Spur. Resp. Attenuation*:

- 1) Double-click *CDMA 2000 Int. Spur. Resp. Atten./ Test 1* in the list of the selected test items.

The window *CDMA 2000 Intermodulation Spurious Response Attenuation* appears (see Fig. 3.5.3_5). It provides parameter entry fields for two interfering generators (*SMx Signal*).

Additional Tests on CDMA2000 Mobile Stations

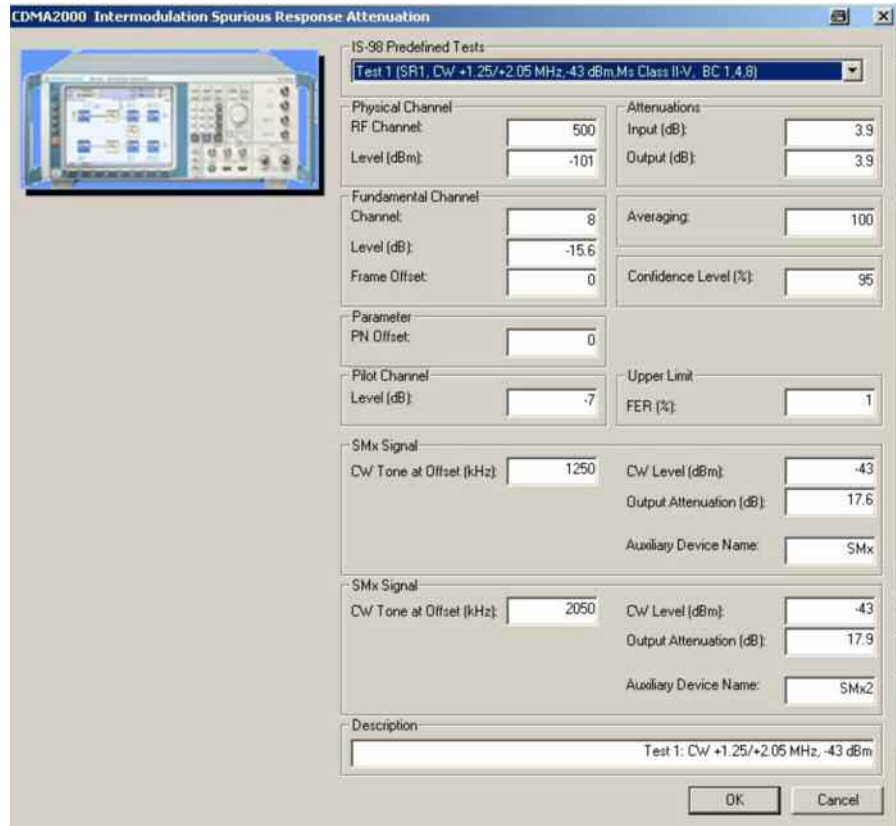

Fig. 3.5.3_5: Setup for CDMA2000[®] intermodulation spurious response attenuation / test 1

Opening the pull-down list *IS-98 Predefined Tests* gives you an overview of the available tests (see Fig. 3.5.3_6):

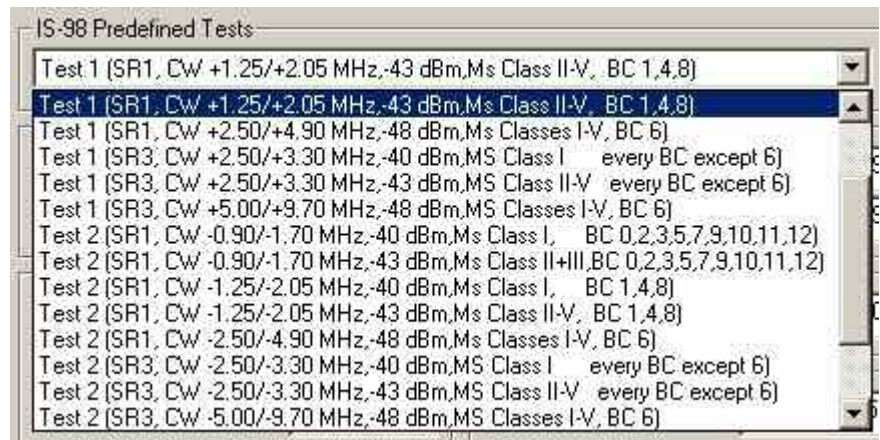

Fig. 3.5.3_6: Predefined tests for CDMA2000[®] intermodulation spurious response attenuation

For each spreading rate (SR), two measurements are stipulated in TIA-98. Test 1 uses interferer frequencies above the assigned channel; test 2 uses interferer frequencies below the assigned channel.

To maintain orientation in Fig. 3.5.3_6, proceed from the right-hand side to the left. Select a line corresponding to the BC of your MS. Then look for a

Additional Tests on CDMA2000 Mobile Stations

suitable line with the appropriate power class (MS Class). This defines the interferer levels. Then choose the spreading rate (SR).

2) Select your *Predefined Test* for this test item.

Each test in Fig. 3.5.3_6 comes with a full set of parameters in accordance with the standard TIA-98. These parameters are CMU and interferer *Levels*, the two CW interferer frequency *Offsets*, the *FER* limit, the *Averaging* count, and the *Confidence Level*.

3) Modify these parameters if necessary.

Listed below are some of the remaining parameters:

- 1) Enter a channel number at *Physical RF Channel*.
- 2) Enter the path loss you measured between the MS and the CMU200 as *Input* and *Output Attenuations*.
- 3) Enter the path loss you measured between the MS and the signal generators as *Output Attenuation* in the SMx fields.
- 4) Enter as *Auxiliary Device Names* the names you specified for the generator's GPIB configuration (see section *Configuring the GPIB settings* on page 6).
- 5) Add a comment if you like.
- 6) Click *OK*.

You are back in the *Configure Test* window (Fig. 3.5.3_2).

7) Configure another item. If necessary, create your own sequence.

You may want to store your sequence. Use the button *Save Sequence* in the *Configure Test* window (see Fig. 3.5.3_2).

8) Finally click *OK* (in the *Configure Test* window).

This completes the measurement setup.

To start the measurement:

- Click the *start icon* in the menu bar of CMUgo (see Fig. 3.5.2_7).

Test description and measurement report:

When the basic initialization is completed, a pop-up menu instructs you to *Switch on the Mobile*. Ignore this message if it is already powered up. After the individual response time of the MS, the CMU200 automatically registers the mobile station and sets up a call connection. The pop-up menu disappears when the call is established.

With the predefined sequence *CDMA2000_3.5.3.seq*, the two following measurements are subsequently run:

Test 1:

The total power of the CMU is set to -101 dB, and Pilot and Traffic power are set to -7 dB and -15.6 dB respectively. Both interferer levels are set to -43 dBm for a Class II mobile station.

The path losses you entered are compensated automatically.

Additional Tests on CDMA2000 Mobile Stations

A first FER measurement is performed with interferer frequency offsets of +1.25 MHz and +2.05 MHz. The result is stored inside CMUgo.

Test 2:

The test is repeated with the same levels but with interferer offsets of -1.25 MHz and -2.05 MHz. The result is stored inside CMUgo.

Once all test steps have been completed, you get a display similar to Fig. 3.5.3_7.

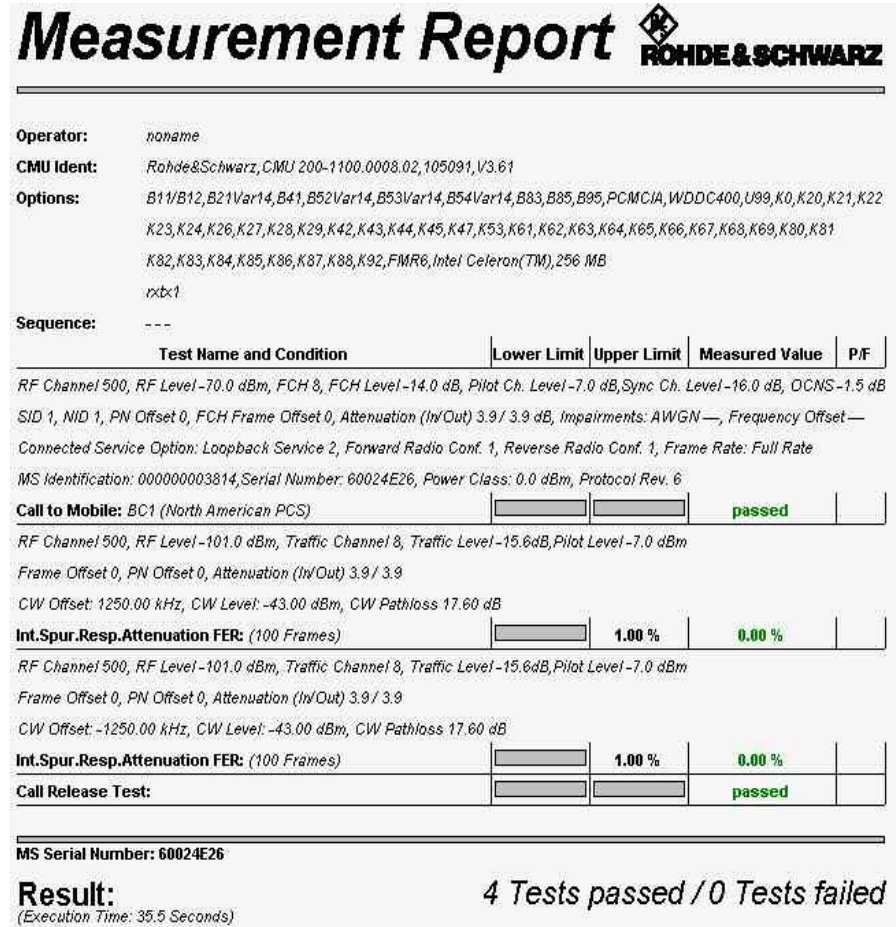

Fig. 3.5.3_7: Test result for intermodulation spurious response attenuation.

Measurement values that are below the limits are displayed in green; those which exceed the limits are displayed in red. In addition, the right-hand column (P/F, for Pass/Fail) indicates whether a test was passed or failed.

To repeat a test sequence, click the start button again (Fig. 3.5.2_7).

If your mobile station supports more than one band class, change the configurations accordingly and start the test sequence again.

3.5.4: Adjacent Channel Selectivity

Adjacent channel selectivity is a measure of a receiver's ability to receive a CDMA signal at its assigned frequency in the presence of another CDMA signal that is offset from the center frequency of the assigned channel by ± 2.5 MHz (for SR 1).

The adjacent channel selectivity is measured by the frame error rate (FER).

The purpose of test 3.5.4 is to verify that the FER of the mobile station does not exceed 1 % with 95 % confidence level under these conditions.

This test is applicable to BC 6 mobile stations only.

Recommended test setup:

Fig. 3.5.4_1 shows the test setup for the adjacent channel selectivity test. It is the same setup that is used for test 3.5.2.

The RF ports of the Radio Communication Tester CMU200 and the mobile station under test are connected by means of a resistive combiner. During the test, a call is set up to the mobile station and a connection is established by the CMU using this path. In addition, a signal generator is coupled in to provide the adjacent channel interferer. The resistive combiner ensures a flat frequency response. The 10 dB attenuator in the generator path decouples the instrument and reduces the CDMA signals at the generator input to a harmless level.

Both the CMU and the signal generator are remote-controlled by CMUgo to run the test automatically.

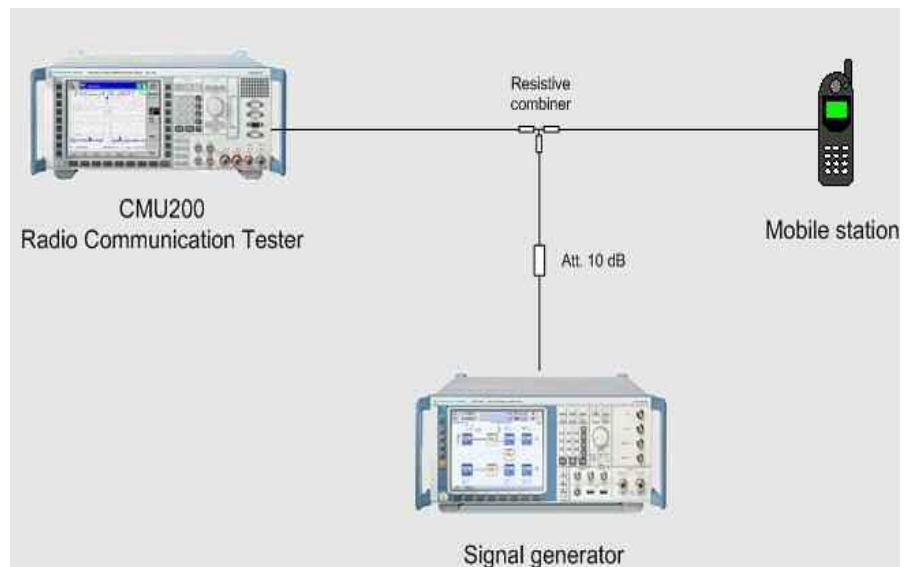

Fig. 3.5.4_1: Test setup for adjacent channel selectivity test

Instruments and accessories:

- CMU200, SMU or SMJ or SMIQ or SML
- Resistive combiner, frequency response depending on the band class (recommended: Weinschel 1515-1, DC to 12.75 GHz)

Path loss compensation:

(see previous section)

- Measure the path loss between the MS and the CMU200
- Measure the path loss between the MS and the signal generator

Test procedure:

- 1) Connect instruments and mobile station as shown in Fig. 3.5.4_1.
- 2) Run CMUgo, and then click *Configuration, Configure Tests*.

The *Configure Test* window opens.

- 3) Click *Load Sequence*, and select *CDMA2000_3.5.4.seq*.

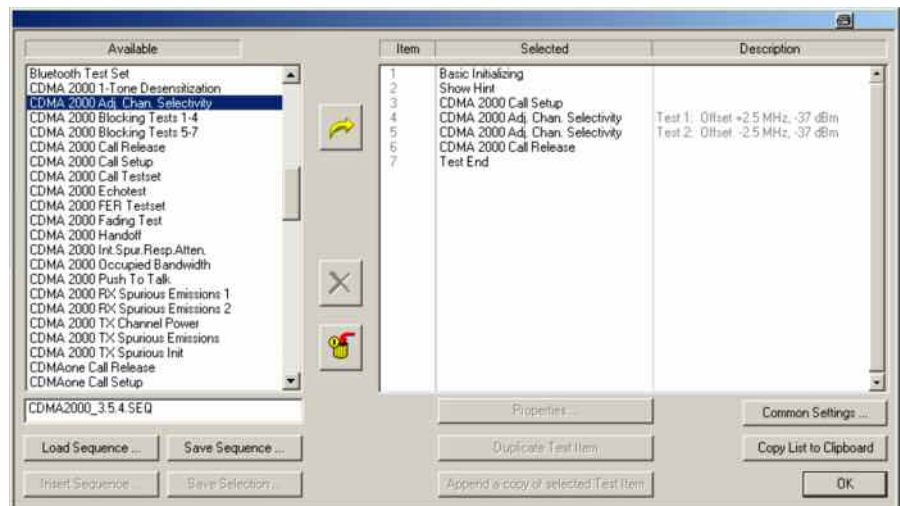

Fig. 3.5.4_2: Available and selected test items (test sequence) for adjacent channel selectivity.

At first check Basic Initializing

Check whether the correct function group inside the CMU is activated (see table 3.5.2_4 at page 10). For BC6 enable *IS-CDMA2000 IMT2K Band*.

Configure test item *CDMA 2000 Call Setup*:

- 1) Double-click *CDMA 2000 Call Setup* in the list of the selected test items.

The window *Call Setup Configuration* opens (see Fig. 3.5.4_3 on page 28).

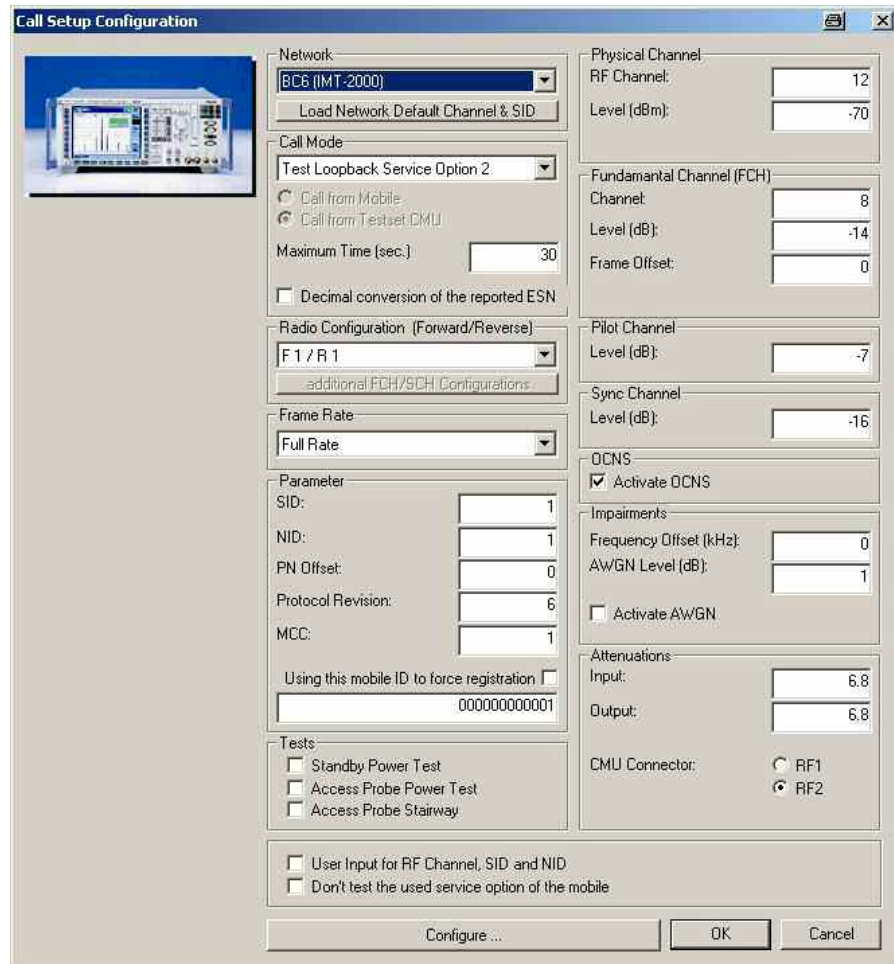

Fig. 3.5.4_3: Call setup configuration for adjacent channel selectivity test.

The adjacent channel selectivity test is applicable to BC 6 mobile stations only.

- 2) Select BC 6 as network.
- 3) Select one *Call Mode* depending on the radio configuration (RC) your mobile station supports, e.g. Service Option 2.

Depending on the *Call Mode* you selected, the configuration window provides a set of *Radio Configuration* combinations.

- 4) Select your *Radio Configuration (Forward/Reverse)* combination.
- 5) Enter a channel number for the call setup at *Physical RF Channel*.
- 6) Enter the path loss you measured between the MS and the CMU200 as *Input Attenuation* and *Output Attenuation*.
- 7) Make sure that *Activate OCNS* is enabled.

You may modify the other parameters if necessary.

- 8) Click *OK*.

You are back in the *Configure Test* window (Fig. 3.5.4_2 on page 27).

Additional Tests on CDMA2000 Mobile Stations

Configure test items *CDMA 2000 Adjacent Channel Selectivity*:

- 1) Double-click *CDMA 2000 Adj. Chan. Selectivity / Test 1* in the list of the selected test items.

The window *CDMA2000 Adjacent Channel Selectivity* configuration appears (see Fig. 3.5.4_4).

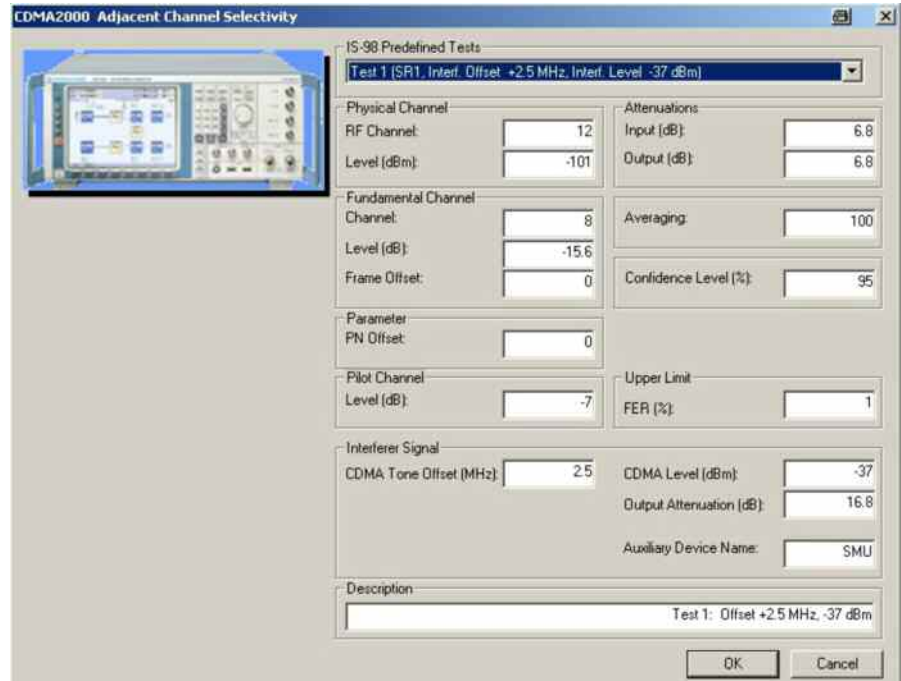

Fig. 3.5.4_4: Setup for CDMA2000[®] adjacent channel selectivity / test 1

Opening the pull-down list *IS-98 Predefined Tests* shows you the available tests (see Fig. 3.5.4_5):

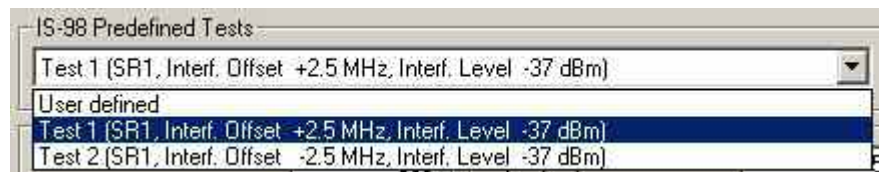

Fig. 3.5.4_5: Predefined tests for CDMA2000[®] adjacent channel selectivity.

Test 1 uses an interferer frequency above the assigned channel; test 2 uses an interferer frequency below the assigned channel. SR 3 is not provided.

Predefined parameters are CMU and interferer *Levels*, the CW interferer frequency *Offset*, the *FER* limit, the *Averaging* count, and the *Confidence Level*.

If you modify one of these entries, the selection changes to *User defined*.

- 2) Select your test.
- 3) Modify parameters if necessary.

Additional Tests on CDMA2000 Mobile Stations

Listed below are some of the remaining parameters:

- 1) Enter a channel number at *Physical RF Channel*.
- 2) Enter the path loss you measured between the MS and the CMU200 as *Input* and *Output Attenuations*.
- 3) Enter the path loss you measured between the MS and the signal generator as *Output Attenuation* in the SMx field.
- 4) Enter as *Auxiliary Device Name* the name you specified for the generator's GPIB configuration (see section *Configuring the GPIB settings* on page 6).
- 5) Add a comment if you like.
- 6) Click *OK*.

You are back in the *Configure Test* window (Fig. 3.5.4_2).

- 7) Configure another item. If necessary, create your own sequence.

You may want to store your sequence. Use the button *Save Sequence* in the *Configure Test* window (see Fig. 3.5.4_2).

- 8) Finally click *OK* (in the *Configure Test* window).

This completes the measurement setup.

To start the measurement:

- Click the start icon in the menu bar of CMUgo (see Fig. 3.5.2_7).

Test description and measurement report:

When the basic initialization is completed, a pop-up menu instructs you to *Switch on the Mobile*. Ignore this message if it is already powered up. After the individual response time of the MS, the CMU200 automatically registers the mobile station and sets up a call connection. The pop-up menu disappears when the call is established.

With the predefined sequence *CDMA2000_3.5.4.seq*, the two following measurements are subsequently run :

Test 1: The total power of the CMU is set to -101 dB, and Pilot and Traffic power are set to -7 dB and -15.6 dB respectively. The CDMA interferer level is set to -37 dBm.

The path losses you entered are compensated automatically.

A first FER measurement is performed with an interferer frequency offset of $+2.5$ MHz. The result is stored inside CMUgo.

Test 2: The test is repeated with the same levels but with an interferer offset of -2.5 MHz. The result is stored inside CMUgo.

Additional Tests on CDMA2000 Mobile Stations

Once all test steps have been completed, you get a display similar to Fig. 3.5.4_6.

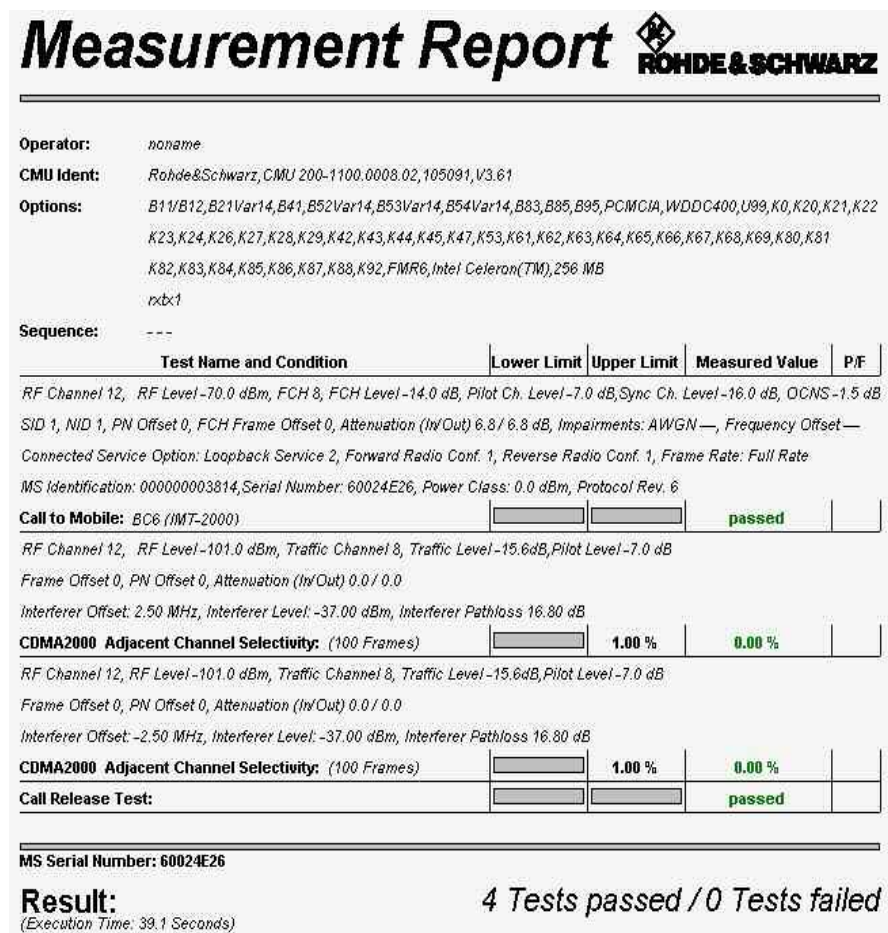

Fig. 3.5.4_6: Test result for adjacent channel selectivity.

Measurement values that are below the limits are displayed in green; those which exceed the limits are displayed in red. In addition, the right-hand column (P/F, for Pass/Fail) indicates whether a test was passed or failed.

To repeat a test sequence, click the start button again (Fig. 3.5.2_7).

3.5.5: Receiver Blocking Characteristics

The receiver blocking characteristics test is a measure of a receiver's ability to receive a CDMA signal at its assigned frequency in the presence of a single tone at frequencies other than those of the adjacent channels, without this unwanted signal causing a degradation of the performance of the receiver beyond a specific limit.

A receiver's receiver blocking performance is measured by the frame error rate (FER).

The purpose of test 3.5.5 is to verify that the FER of the mobile station does not exceed 1 % with 95 % confidence level under these conditions.

This test is applicable to BC 6 mobile stations only.

Recommended test setup:

Fig. 3.5.5_1 shows the test setup for the receiver blocking test. It is the same setup that is used for test 3.5.2 or test 3.5.4, for example.

The RF ports of Radio Communication Tester CMU200 and the mobile station under test are connected by means of a resistive combiner. During the test, a call is set up to the mobile station and a connection is established by the CMU using this path. In addition, a signal generator is coupled in to provide the blocking interferer. The resistive combiner ensures a flat frequency response. The 10 dB attenuator in the generator path decouples the instrument and reduces the CDMA signals at the generator input to a harmless level.

Both the CMU and the signal generator are remote-controlled by CMUgo to run the test automatically.

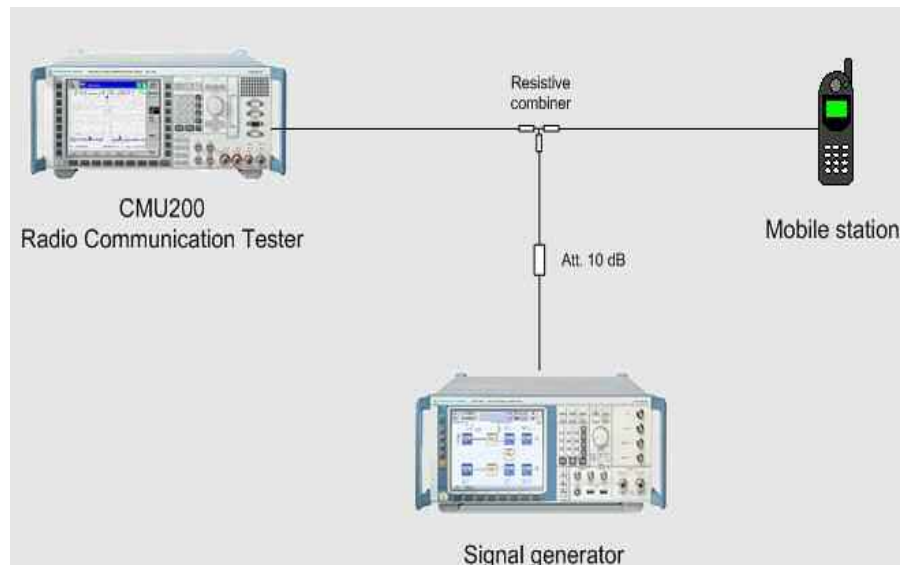

Fig. 3.5.5_1: Test setup for receiver blocking test.

Seven RX blocking tests can be found in section 3.5.5 of the standard TIA-98. Tests 1 to 4 are in-band-tests. Here the interfering signal occurs each time at a fixed frequency offset from the assigned channel (inside the

Additional Tests on CDMA2000 Mobile Stations

CDMA band). These tests are performed using test items *CDMA 2000 Blocking Tests 1-4*.

The interferers of tests 5 to 7 use frequencies out of the CDMA band. Tests 5 to 7 are not based on only one measurement: The interferer is subsequently applied at all frequencies of a 1 MHz grid between the lower and the upper end of specified frequency bands. These tests are performed using test items *CDMA 2000 Blocking Tests 5-7*.

At first check Basic Initializing

Check whether the correct function group inside the CMU is activated (see table 3.5.2_4 at page 10).

In-Band Blocking:

Instruments and accessories:

- CMU200, SMU or SMJ or SMIQ or SML
- Resistive combiner (e.g. Weinschel 1515-1, DC to 12.75 GHz)

Path loss compensation:

(see previous section)

- Measure the path loss between the MS and the CMU200
- Measure the path loss between the MS and the signal generator for the different frequency bands of this tests

Test procedure:

- 1) Connect instruments and mobile station as shown in Fig. 3.5.5_1.
- 2) Run CMUgo, and then click *Configuration, Configure Tests*.

The *Configure Test* window opens.

- 3) Click *Load Sequence*, and select *CDMA2000_3.5.5.1-4.seq*.

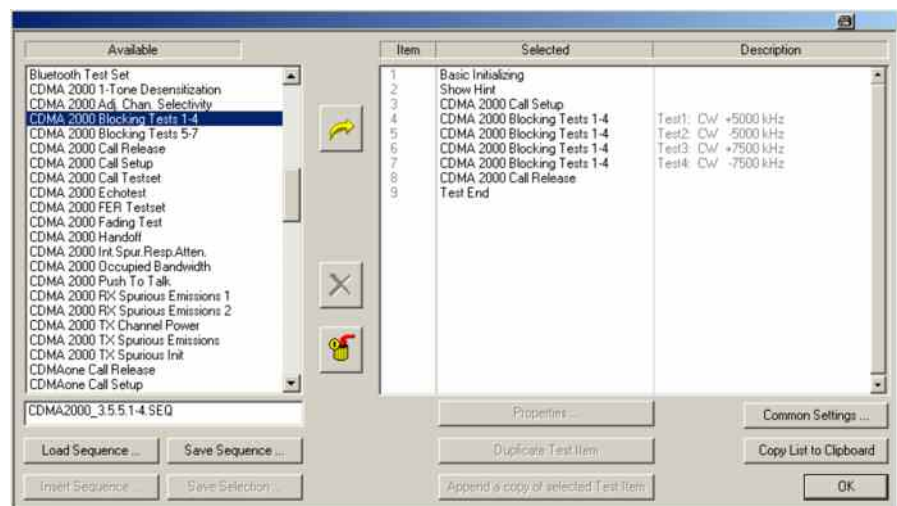

Fig. 3.5.5_2: Available and selected test items (test sequence) for in-band blocking test..

Configure test item *CDMA 2000 Call Setup*:

- 1) Double-click *CDMA 2000 Call Setup* in the list of the selected test items.

The window *Call Setup Configuration* opens.

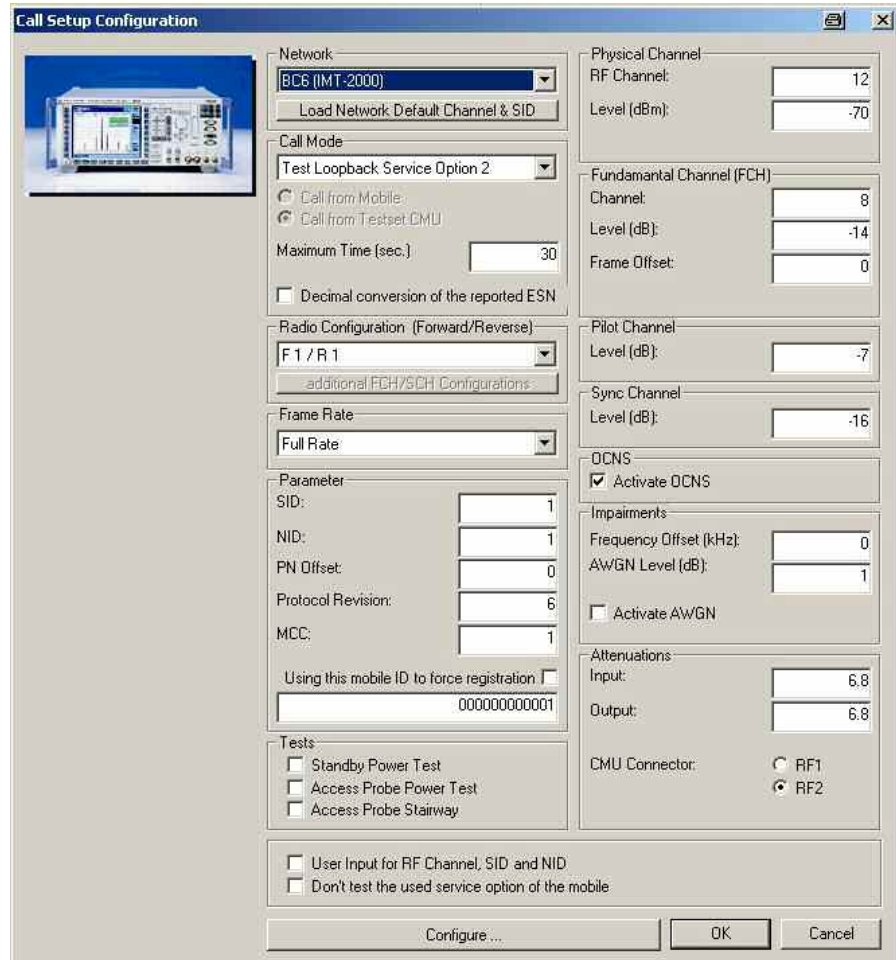

Fig. 3.5.5_3: Call setup configuration for blocking test.

The receiver clocking characteristics test is applicable to BC 6 mobile stations only.

- 2) Select BC 6 as network.
- 3) Select one *Call Mode* depending on the Radio Configuration (RC) your mobile station supports, e.g. Service Option 2.

Depending on the *Call Mode* you selected, the configuration window provides a set of *Radio Configuration* combinations.

- 4) Select your *Radio Configuration (Forward/Reverse)* combination.
- 5) Enter a channel number for the call setup at *Physical RF Channel*.
- 6) Enter the path loss you measured between the MS and the CMU200 as *Input Attenuation* and *Output Attenuation*.

Additional Tests on CDMA2000 Mobile Stations

7) Make sure that OCNS is activated.

You may modify the other parameters if necessary.

8) Click OK.

You are back in the *Configure Test* window (Fig. 3.5.5_2):

Configure test items **CDMA 2000 Blocking 1-4 (In-Band):**

1) Double-click *CDMA 2000 RX In-Band-Blocking / Test 1* in the list of the selected test items.

The window *CDMA2000 Blocking Characteristics (In-Band)* appears (see Fig. 3.5.5_4).

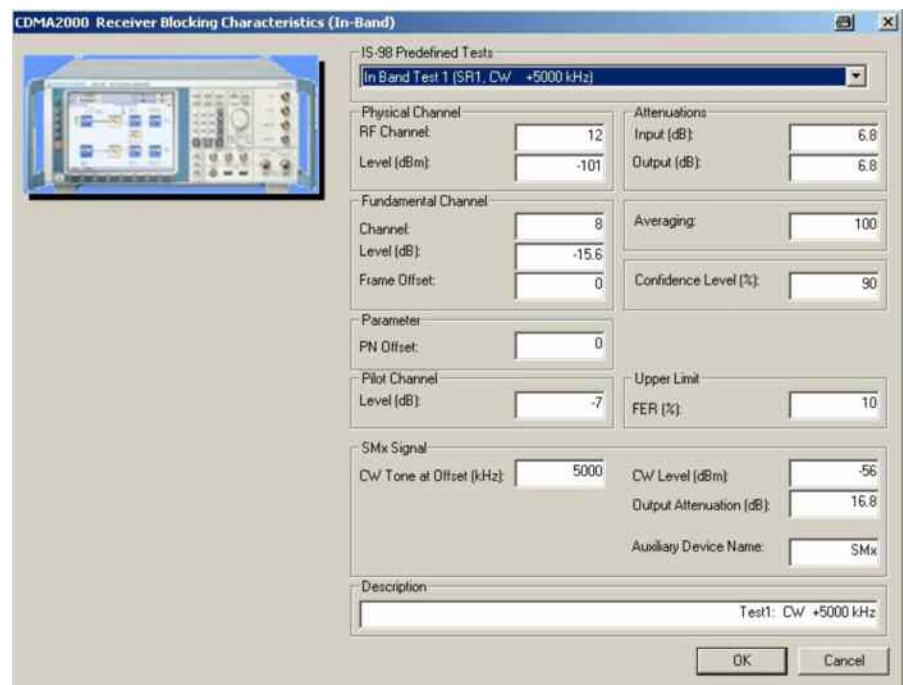

Fig. 3.5.5_4: Setup for CDMA2000® for in-band blocking / test 1

Opening the pull-down list *IS-98 Predefined Tests* shows you the available tests (see Fig. 3.5.5_5):

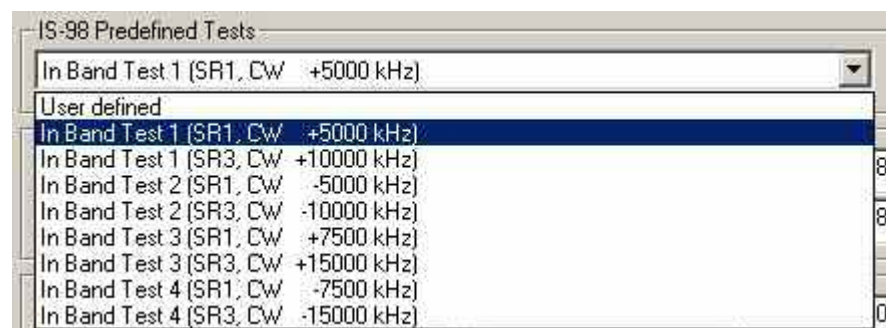

Fig. 3.5.5_5: Predefined tests for CDMA2000® for in-band blocking characteristics.

Additional Tests on CDMA2000 Mobile Stations

For each in-band test, the following parameters are predefined:

CMU and interferer *Levels*, the CW interferer frequency *Offset*, the *FER* limit, the *Averaging* count, and the *Confidence Level*.

If you modify one of these entries, the selection changes to *User defined*.

- 2) Select your test.
- 3) Modify parameters if necessary.

Listed below are some of the remaining parameters:

- 1) Enter a channel number at *Physical RF Channel*.
- 2) Enter the path loss you measured between the MS and the CMU200 as *Input* and *Output Attenuations*.
- 3) Enter the path loss you measured between the MS and the signal generator as *Output Attenuation* in the SMx field.
- 4) Enter as *Auxiliary Device Name* the name you specified for the generator's GPIB configuration (see section *Configuring the GPIB settings* on page 6).
- 5) Add a comment if you like.
- 6) Click *OK*.

You are back in the *Configure Test* window (Fig. 3.5.5_2).

To start the measurement:

- Click the start icon in the menu bar of CMUgo (see Fig. 3.5.2_7).

Test description and measurement report:

When the basic initialization is completed, a pop-up menu instructs you to *Switch on the Mobile*. Ignore this message if it is already powered up. After the individual response time of the MS, the CMU200 automatically registers the mobile station and sets up a call connection. The pop-up menu disappears when the call is established.

With the predefined sequence *CDMA2000_3.5.5.seq*, the following measurements are subsequently run:

The total power of the CMU is set to -101 dB, and Pilot and Traffic power are set to -7 dB and -15.6 dB respectively. The CDMA interferer level is set to -56 dBm for tests 1 and 2, and to -44 dBm for tests 3 and 4.

The path losses you entered are compensated automatically.

FER measurements are performed with the interferer frequency offset as specified in the test items. The result is stored inside CMUgo.

Once all test steps have been completed, you get a display similar to Fig. 3.5.5_6 (on page 37):

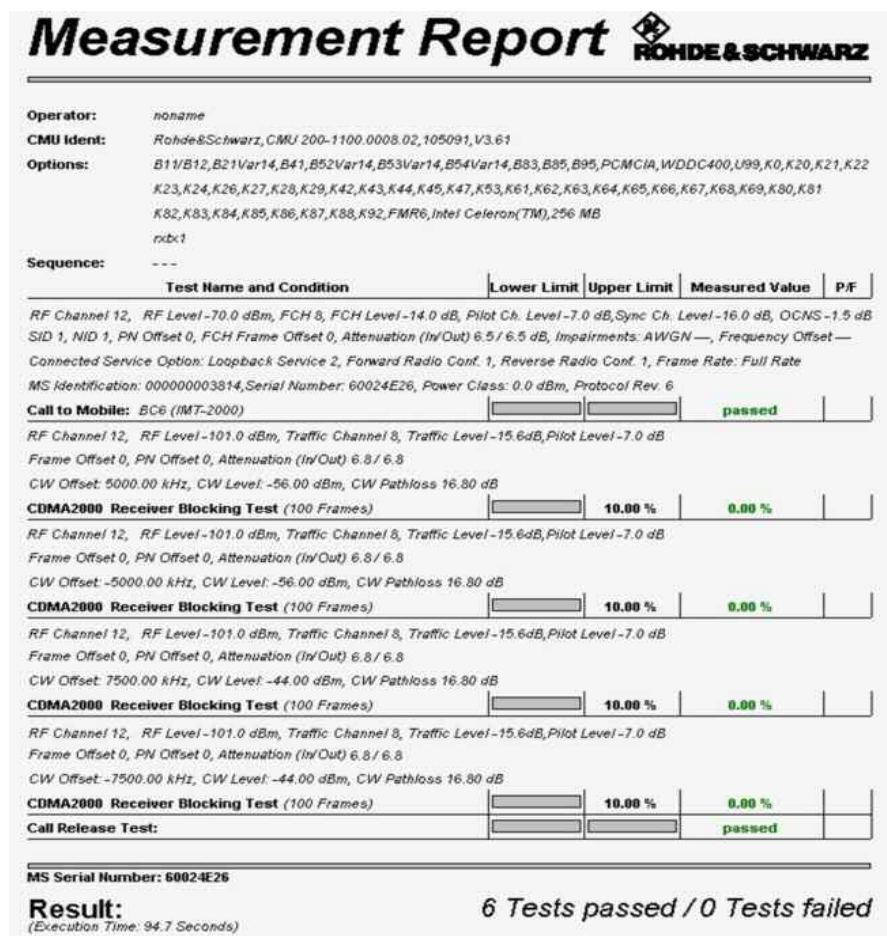

Fig. 3.5.5_6: Measurement report for blocking tests 1-4.

Measurement values that are below the limits are displayed in green; those which exceed the limits are displayed in red. In addition, the right-hand column (P/F, for Pass/Fail) indicates whether a test was passed or failed.

Out-Of-Band-Blocking:

Unlike the in-band tests 1 to 4 the out-of-band tests 5 to 7 are not based on only one measurement: The interferer is subsequently applied at all frequencies between the lower and the upper end of specified frequency bands in 1 MHz steps. Apart from that, there are no differences to the in-band-blocking tests.

Test procedure:

- Use sequence *CDMA2000_3.5.5.5-7.seq* and proceed in the same way as for in-band-blocking.

Additional Tests on CDMA2000 Mobile Stations

Fig. 3.5.5_7 shows the configuration window for the out-of-band tests:

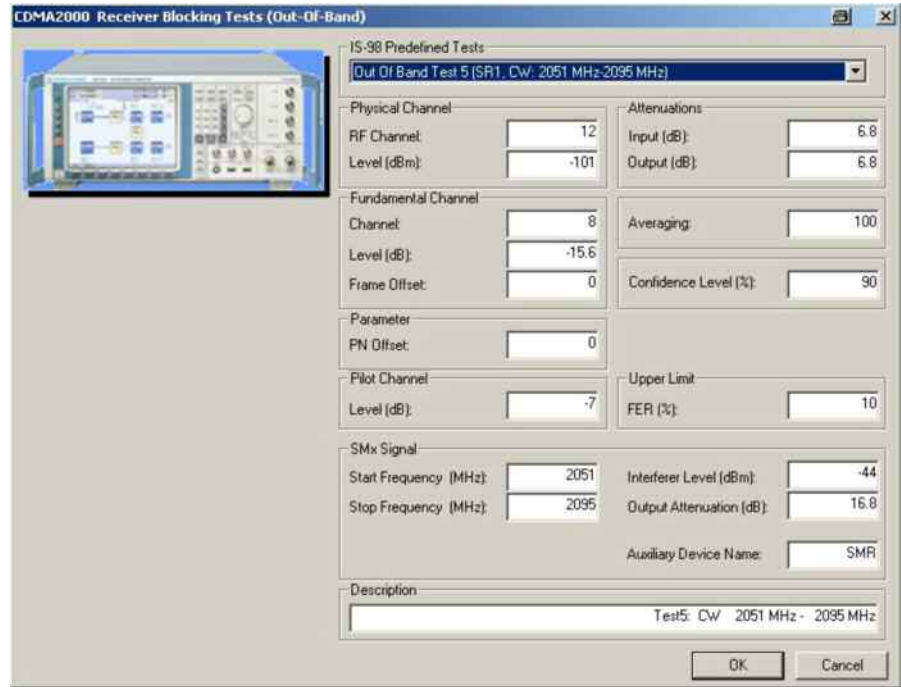

Fig. 3.5.5_7: Setup for CDMA2000[®] for out-of-band blocking

In the SMx field you now have entries for *Start* and *Stop Frequency* of the section where the interferer signal has to pass through on a 1 MHz grid.

The pull-down list *IS-98 Predefined Tests* shows you the available tests:

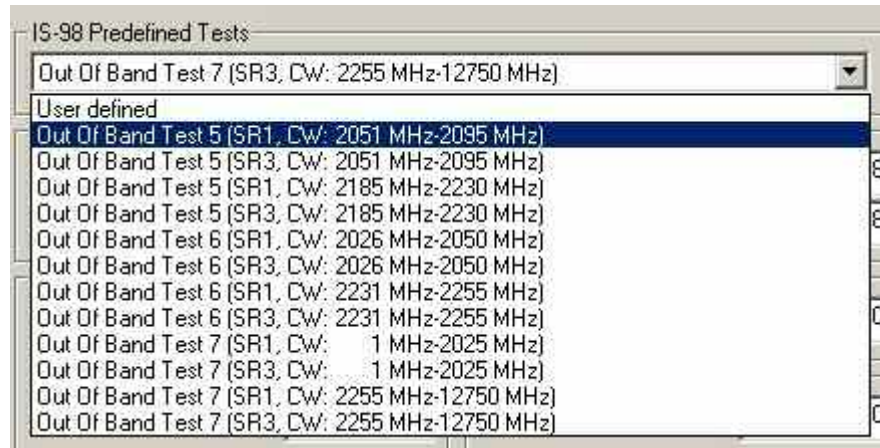

Fig. 3.5.5_8: Predefined tests for CDMA2000[®] for out-of-band blocking characteristics. (SR1 and SR3 use different levels for the fundamental channel.)

Notes: For the higher frequencies of test 7, you need the SMR signal generator. We recommend splitting this test into several measurements with smaller frequency sections than the two wide frequency sections specified by the standard. For the smaller sections you can enter a more precise attenuation.

Due to the large number of FER measurements the test duration is considerable long.

To stop a running measurement:

- Click the stop icon in the menu bar of CMUgo (see Fig. 3.5.5_8).

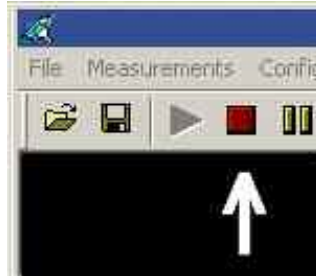

Fig. 3.5.5_8: Stop icon

If you stop a measurement while *Show Hint* fills the screen, the measurement report remains invisible in the background. To make it visible click one of the *Zoom* buttons, see Fig. 3.5.5_9:

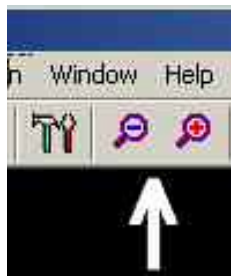

Fig. 3.5.5_9: Zoom icons

Fig. 3.5.5_9 (on page 40) shows you a typical measurement result. The stop frequency for Test 7 was set to 3 GHz.

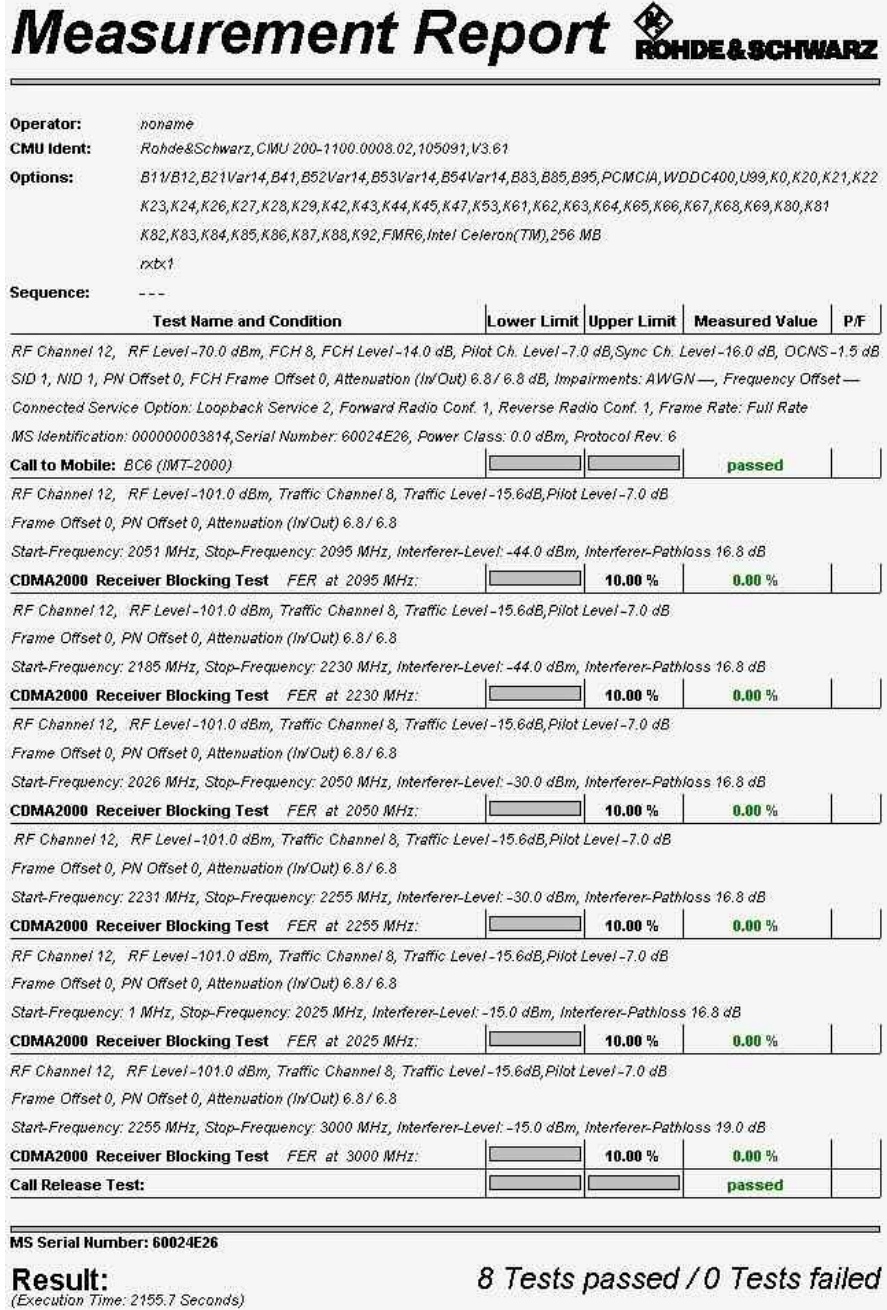

Fig. 3.5.5_9: Measurement report for blocking tests 5-7.

If no limits are exceeded the worst test result is displayed. If there are limits exceeded each violation will be indicated.

However, the program stops if there are more than 25 violations, because for the out-of-band tests 6 and 7, altogether 24 exceptions (where the FER limit is exceeded) are permitted.

In this case, repeat the tests with the interferer set to the lower *Alternate CW Tone Power* of -44 dB. If the FER does not exceed 10 % at 90 % confidence level now, the test has been passed.

Note: If you break a test the last result on the screen could be not valid.

3.6.1: RX Conducted Spurious Emissions

RX conducted spurious emissions are spurious emissions generated or amplified in the mobile station's receiver that appear at the mobile station antenna connector. There is no forward or reverse CDMA channel active during this test.

The conducted spurious emissions are measured with a spectrum analyzer connected to the mobile station's antenna port.

The purpose of test 3.6.1 is to verify that the emissions of the mobile station do not exceed a specific set of limits.

This test is performed for each band class the mobile stations supports.

Recommended test setup:

Fig. 3.6.1_1 shows the test setup for test RX conducted spurious emissions.

The RF ports of the mobile station and the analyzer are simply connected to each other. There is no call setup or radio connection established between the CMU and the mobile station. Nevertheless, the CMU is needed to start program CMUgo.

The spurious emission measurements are made automatically, remote-controlled by CMUgo.

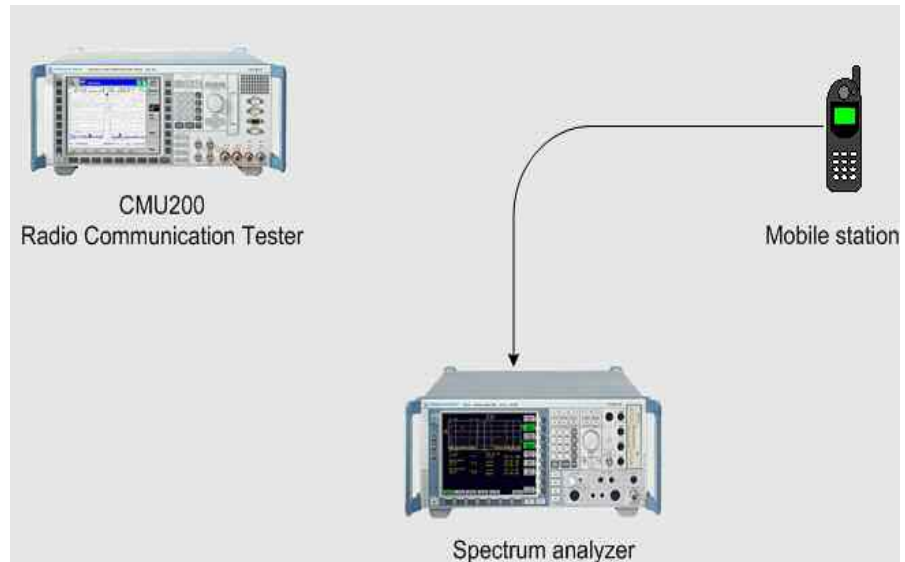

Fig. 3.6.1_1: Test setup for RX spurious emission test.

Test 3.6.1 contains in-band (RX / TX) and out-of band measurements.

Notes: In the RX band very low emissions are measured. This requires a high sensitive test equipment, and good shielding. The RF attenuation of the analyzer is set to 0 dB for this tests.

- To avoid overloading the analyzer make sure that the DUT does not transmit during the test.
- Use a shielded chamber for the DUT (e.g. CMU-Z11).
- Use well shielded cables.

Additional Tests on CDMA2000 Mobile Stations

Instruments and accessories:

- CMU200
- FSQ or FSU or FSP or FSL with preamplifier FSL-B22.

Path loss compensation:

(see previous section)

- Measure the path loss between the MS and the spectrum analyzer

Test procedure:

- 1) Connect the analyzer and the mobile station as shown in Fig. 3.6.1_1.
- 2) Run CMUgo, and then click *Configuration, Configure Tests*.

The *Configure Test* window opens.

- 3) Click *Load Sequence*, and select *CDMA2000_3.6.1.seq*.

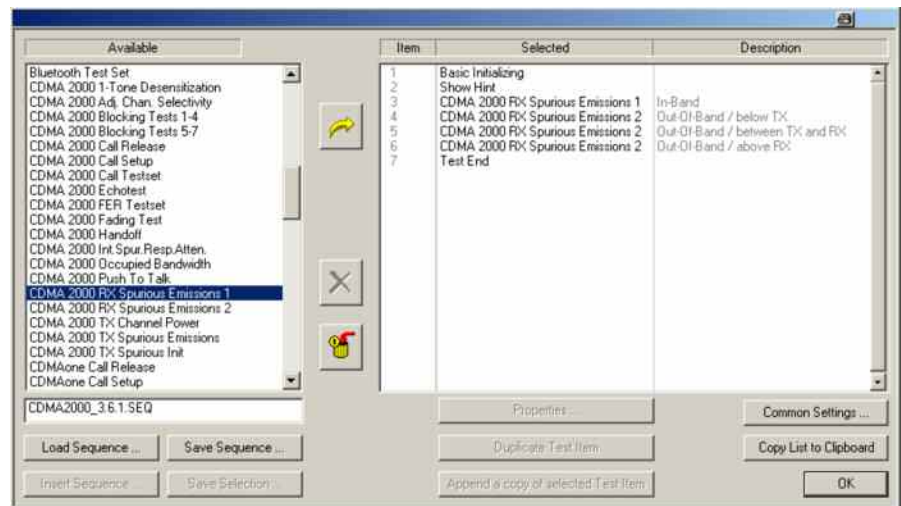

Fig. 3.6.1_2: Available and selected test items (test sequence) for RX spurious emission test.

For each band class, the standard TIA-98 provides a set of limits for various frequency ranges such as the receive band, the transmit band and out-of-band sections. Use test item *CDMA 2000 RX Spurious Emissions 1* for in-band measurements, and the items *CDMA 2000 RX Spurious Emissions 2* for out-of-band measurements. Four sections are treated separately in sequence *CDMA2000_3.6.1.seq*:

- in-band
- below the TX band
- between the TX and RX bands, and
- above the RX band.

There is no Call Setup, no Call Connection, no Forward or Reverse signal present during this test. Nevertheless, CMUgo does not start without the *Basic Initializing*, which requires that the CMU200 is connected to the GPIB port.

Configure test items *CDMA 2000 RX Spurious Emissions 1:*

- 1) Double-click *CDMA 2000 Spurious Emissions 1* in the list of the selected test items.

The window *CDMA2000 RX Conducted Spurious Emissions* for in-band appears (see Fig. 3.6.1_3).

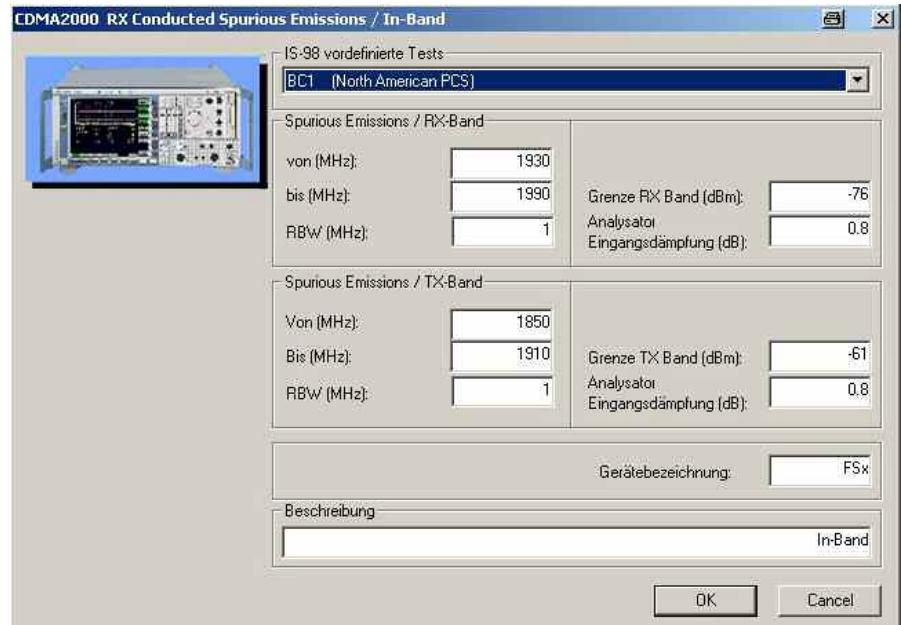

Fig. 3.6.1_3: Setup for CDMA2000[®] RX conducted spurious emissions / in-band.

The in-band window defines the spurious emissions in the RX as well as in the TX band. Opening the pull-down list *IS-98 Predefined Tests* shows you the available in-band tests (see Fig. 3.6.1_4):

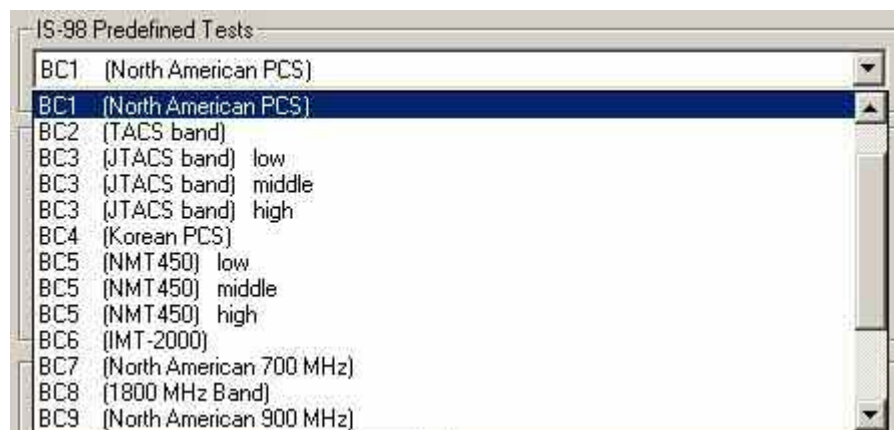

Fig. 3.6.1_4: Predefined in-band tests for CDMA2000[®] RX conducted spurious emissions / in-band.

For BC3, BC5, BC10, and BC11, the RX and TX bands are not continuous but have gaps. Consequently you find three predefined tests, e.g. for the three subsections of BC3 bands.

Additional Tests on CDMA2000 Mobile Stations

Predefined parameters are the *From and To Frequencies*, the *RBW*, and the *Limits*.

If you modify one of these entries, the selection changes to *User defined*.

- 2) Select your test.
- 3) Modify parameters if necessary.

Listed below are some of the remaining parameters:

- 1) Enter the path loss you measured between the MS and the spectrum analyzer as *Analyzer Input Attenuation*.
- 2) Enter as *Auxiliary Device Name* the name you specified for the analyzer's GPIB configuration (see section *Configuring the GPIB settings* on page 6).
- 3) Add a comment if you like.
- 4) Click *OK*.

You are back in the *Configure Test* window (Fig. 3.6.1_2).

- 5) Configure the next test item.
- 6) If necessary, create your own sequence.

You may want to store your sequence. Use the button *Save Sequence* in the *Configure Test* window (see Fig. 3.6.1_2).

- 7) Finally click *OK* (in the *Configure Test* window).

This completes the measurement setup.

To start the measurement:

- Click the start icon in the menu bar of CMUgo (see Fig. 3.5.2_7).

Test description and measurement report:

When the basic initialization is completed, the specified sections of the spectrum are scanned one after the other. For each section scanned, the maximum measured value is stored in CMUgo.

Once all steps have been completed, you get a display similar to Fig. 3.6.1_5 (on page 45).

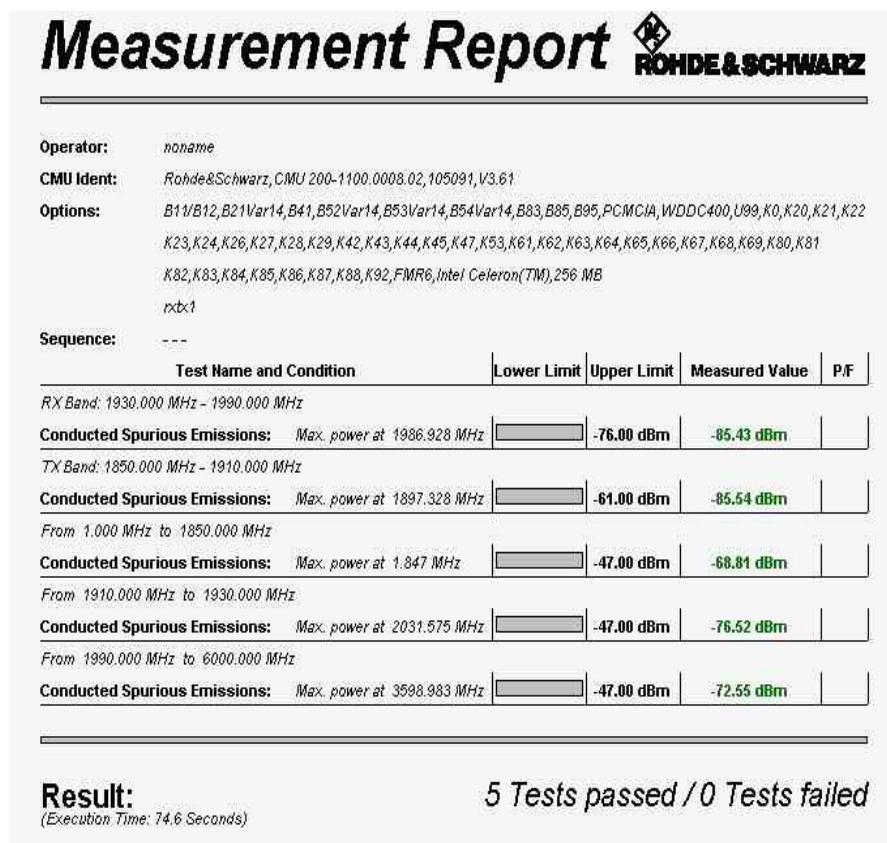

Fig. 3.6.1_5: Test result for CDMA2000[®] RX conducted spurious emissions.

The report screen displays the maximum emission and the frequency at which the maximum has been detected. Measurement values that are below the limits are displayed in green; those which exceed the limits are displayed in red. In addition, the right-hand column (P/F, for Pass/Fail) indicates whether a test was passed or failed.

To repeat a test sequence, click the start button again (Fig. 3.5.2_7).

If your mobile station supports more than one band class, change the item configurations accordingly and start the test sequence again.

Receiver Tests in Multipath Fading Channel

Overview

The receiver tests in multipath fading channel show how well the mobile station demodulates a CDMA traffic channel under realistic propagation conditions. Unlike other tests using static signals, the RF input at the mobile antenna changes over time as if the mobile station were moving and received the forward signal simultaneously via different reflections.

Fig. 5_1 shows a car with a mobile radio installed, driving in a typical urban situation. You see some (of many) routes a Node B transmitter signal takes at this point to reach the antenna on the car. Since the car is moving, the routes may be completely different an instant later.

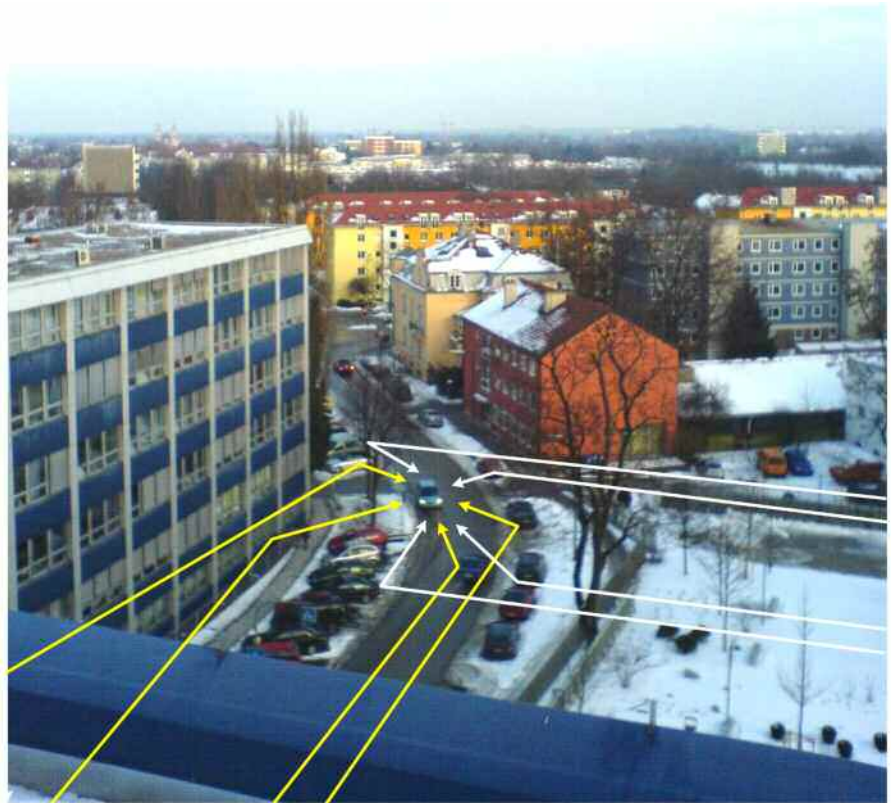

Fig. 5_1: Typical multipath condition in the city for a mobile radio installed in a car.

Reflected signals differ in attenuation and length (delay). We will call a set of routes with nearly the same delay one "path". The yellow lines in Fig. 5_1 belong to one path, the white lines to another. If there is no direct line of sight between Node B and the mobile station, the sum of the reflected signals of one path represents a "Rayleigh" fading profile.

Each mobile standard defines its own characteristic fading profiles. During a test, the stipulated profile is calculated inside a channel simulator in realtime. Measurements can thus be repeated at any time, providing the same results.

Additional Tests on CDMA2000 Mobile Stations

The standard TIA-98 stipulates the following six CDMA2000® fading profiles:

- configuration 1: speed 8 km/h, 2 Rayleigh paths
- configuration 2: speed 14 or 30 km/h depending on Band Class, 2 Rayleigh paths
- configuration 3: speed 30 km/h, 1 Rayleigh path
- configuration 4: speed 100 km/h, 3 Rayleigh paths
- configuration 5: speed 0 km/h, 2 Rayleigh paths
- configuration 6: speed 3 km/h, 1 Rayleigh path

Measure the performance of the mobile station in multipath fading in the same way as in non-fading receiver tests. Apply a forward signal with predefined channel configuration and RF level, and check the Frame Error Rate (FER) or the Bit Error Rate (BER) for each frame category (data rate) supported by the mobile station.

3.4.2, 3.4.7 - 3.4.9: Demodulating the Forward Channel

Each of the receiver tests in sections 3.4.2, 3.4.7, 3.4.8, and 3.4.9 of the standard TIA-98 is about "*demodulation of the forward traffic channel in multipath fading*" conditions. Since all of these tests use the same hardware configuration and only differ in their parameters, they are discussed together in this section. CMUgo offers one common test item for all four tests.

Fig. 5_2 shows the functional hardware setup for the fading tests as outlined in the standard, using an RF fading channel simulator.

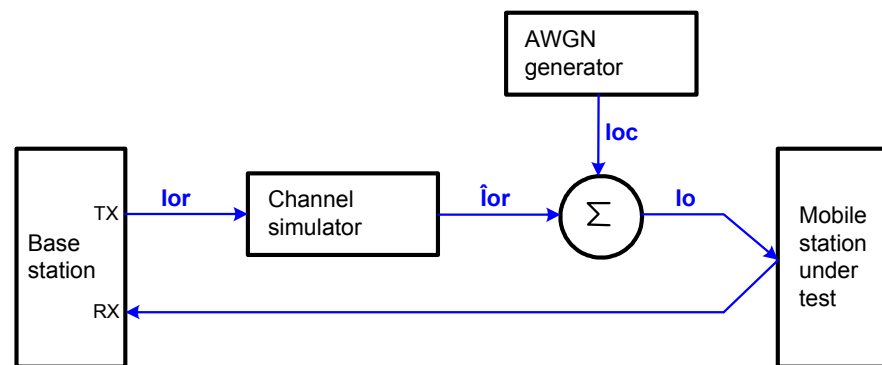

Fig. 5_2: Functional setup for fading tests in the standard TIA-98.

The RF channel simulator transforms the static level TX signal I_{or} into the fading signal \hat{I}_{or} . An AWGN generator adds white noise I_{oc} to simulate other

non-CDMA channels. I_o is the signal summary at the antenna of the mobile station under test.

In this Application Note, the fading profiles are generated in the baseband (and AWGN is added). This method has two major advantages over an RF channel simulator:

- **Baseband fading ensures optimum signal quality**

Any RF-channel simulator has to convert the RF signal down to a low intermediate frequency before applying a fading profile. This is followed by an up-conversion. Each conversion causes signal distortion and additional noise, and could decrease the dynamic range. Baseband fading does not need conversions; there are no such impairments.

- **Automatic calibration is provided inside the SMU. No external measurements are necessary**

The most critical parameters for the receiver measurements are the absolute signal power \hat{I}_{or} and the ratio \hat{I}_{or} / I_{oc} . (signal to AWGN). With an external channel simulator, you have to measure both signals and adjust the levels precisely. Using baseband techniques, the ratio \hat{I}_{or} / I_{oc} is automatically set correctly inside the SMU, and the correct absolute power can be adjusted at the CMU200 without a measurement. Moreover, one single baseband calibration is valid even if the RF channel changes.

Recommended test setup:

Fig. 5_3 shows the hardware setup for CDMA2000[®] fading tests with an SMU.

The CMU200 generates the CDMA2000[®] forward channel in the baseband and provides it at the IQ outputs of the option CMU-B17. This signal is fed to the baseband inputs of the SMU generator. Inside the SMU, fading profiles are applied and AWGN is added. Then the signal is returned from the SMU baseband outputs to the IQ inputs of the option CMU-B17, and up-converted into the RF band.

For connecting the instruments, the option CMU-B17 includes a dedicated cable with an DSUB connector to the CMU200 and BNC connectors to the SMU.

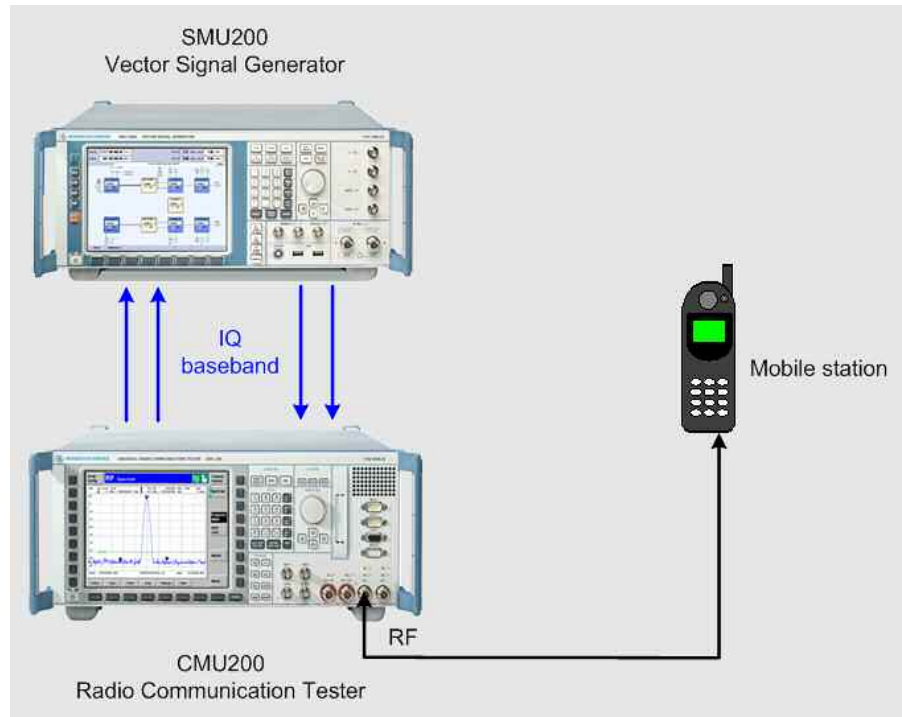

Fig. 5_3: Hardware setup for CDMA2000[®] fading tests.

Instruments and accessories:

- CMU200 including CMU-B17 I/Q-IF interface
- SMU incl. options SMU-B14, B15 Fading Simulator
SMU-B17 Baseband Input
SMU-K62 AWGN

Path loss compensation:

- Measure the RF cable loss between the mobile station and the CMU200. Enter this value later as *Input / Output Attenuation* in the *CDMA 2000 Call Setup* panel, and as *Cable Loss* in the test item *CDMA 2000 Fading SMU*. The CMU200 will then compensate for this amount automatically.

Fading path:

Fig. 5_4 illustrates the signal processing in the baseband, displayed on the SMU generator screen.

Inside the SMU, only the blue blocks are active. The IQ input signals are fed into the baseband block Fading A, where the requested profiles are generated. Afterwards they are sent to the AWGN / Impairment block, which adds the white noise.

Additional Tests on CDMA2000 Mobile Stations

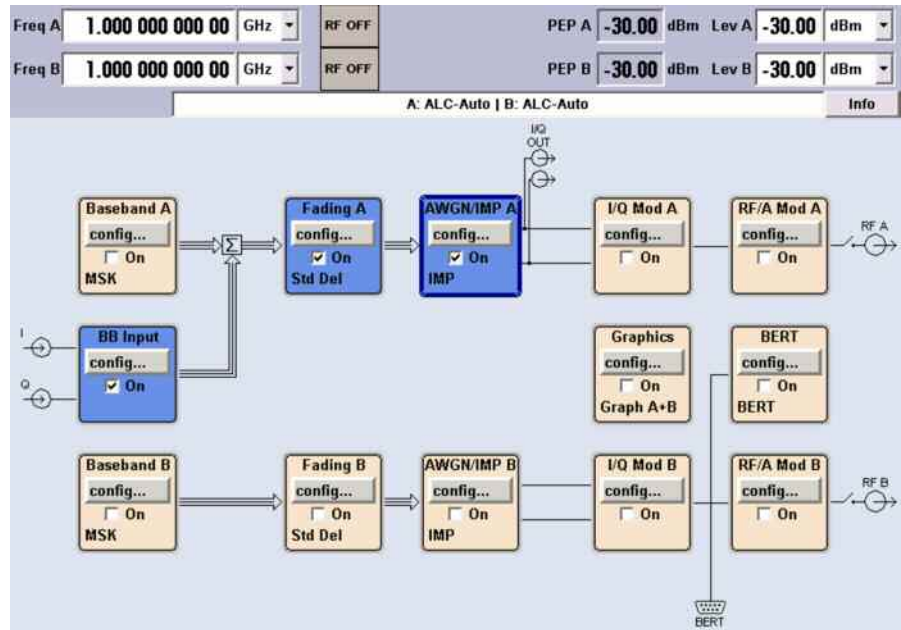

Fig. 5_4: Functional signal processing inside the SMU.

In the baseband path, the levels vary several times; see Fig. 5_5:

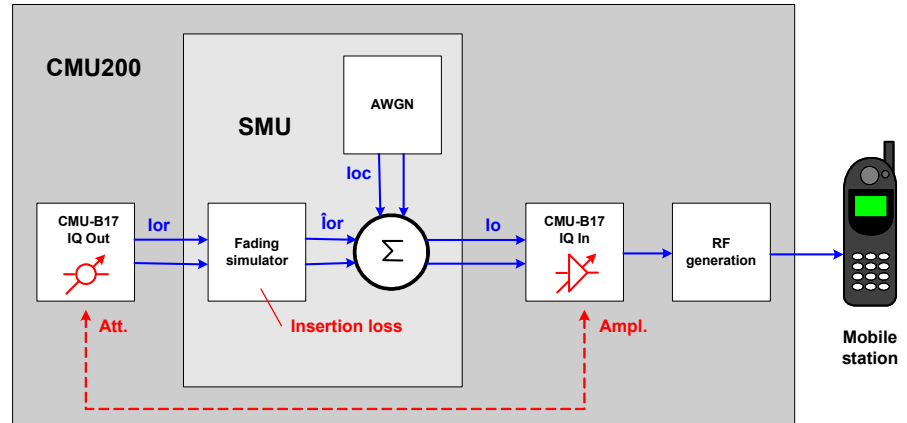

Fig. 5_5: Level variation in the fading path

Due to the high crest factor of CDMA2000® signals, the average level at the CMU baseband outputs is already reduced in the CMU-B17 before reaching the SMU inputs. If the checkbox *SMU Baseband Input Calibration* in the multipath test item is enabled (see Fig. 5_10), the SMU measures the level at its IQ inputs. The attenuation *Att.* in Fig. 5_5 is the difference between full scale and the measured level.

To avoid clipping, the fading simulator further reduces the baseband level. This attenuation is called *insertion loss* in Fig. 5_5.

- The SMU knows both attenuations, and adjusts the actual internal AWGN level automatically to maintain the required ratio \hat{I}_{or} / I_{oc} .

Whereas the level attenuation *Att.* in the CMU-B17 output block is compensated by an amplifier inside the CMU-B17 input block, the *insertion loss* in Fig. 5_5 is not yet taken into account. If no measures are taken, the RF output of CMU200 would be too low.

The test item *CDMA 2000 Fading SMU* copes with this by simulating a higher output attenuation for the CMU200. The *insertion loss* is added to the RF *cable loss*, and the CMU raises its level correspondingly.

Generic Test Item, Subtests, Sequences

The tests for sections 3.4.2, 3.4.7, 3.4.8, and 3.4.9 of the TIA-98 standard all use the same hardware setup and one common generic test item *CDMA 2000 Fading SMU*.

The tests of the four sections differ in their channel configuration:

Perform the tests from section 3.4.2 on the forward fundamental channel. Perform the tests from sections 3.4.7 and 3.4.9 on the forward fundamental channel if it is supported by the mobile station. Otherwise perform these tests on the forward dedicated control channel (not supported by CMU200). Perform the tests from section 3.4.8 on the forward supplemental channel if it is supported by the mobile station.

To set up the channel configuration use the test item *CDMA 2000 Call Setup*.

Furthermore, the tests differ in their power control configuration; set this up in the test item *CDMA 2000 Fading SMU*.

Perform the measurements for each band class the mobile station supports.

Each of the four sections contains a number of subtests (single measurements) with a specific combination of parameters for the level ratios, the data rates, and the fading simulator configurations. For each subtest, a parameter set is preprogrammed in the test item *CDMA 2000 Fading SMU*.

In addition, CMUgo provides several predefined test sequences for each section 3.4.2, 3.4.7, 3.4.8, and 3.4.9.

From the CMUgo user's point of view, the multipath tests are handled in the same way as tests with static RF level:

- Load a predefined test sequence.
- Adapt the parameters to your application and enter the path losses of your test setup (see section below).
- Save your test sequence for later use.
- Run the test.

Additional Tests on CDMA2000 Mobile Stations

For tests of section 3.4.2, take one of the three following sequences:

CDMA2000_3.4.2_T17.seq uses the parameters from test 17 of the 23 (sub-)tests of chapter 3.4.2. Use this sequence as an example, and modify the parameters as required by your application.

CDMA2000_3.4.2_T01-T23.seq contains all 23 tests. Before running this sequence, delete each subtest from the list that is not applicable to your device under test (e.g. if your mobile receiver does not support the requested radio configuration).

For tests of sections 3.4.7 - 3.4.9, take the following sequences:

CDMA2000_3.4.7_T02-T12.seq runs the tests 2, 4, 6, 8, 10, and 12 of section 3.4.7. (For the odd-numbered tests the parameters are not yet specified up to version F of standard TIA-98.)

CDMA2000_3.4.8_T01-T20.seq uses the parameters from test 1 to test 20 of chapter 3.4.8.

CDMA2000_3.4.9_T05-T16.seq uses the parameters from the tests 5 to 8, and tests 13 to 16 of chapter 3.4.9. For the other tests the parameters are not yet specified up to version F of standard TIA-98.)

The following lines refer to the sequence *CDMA2000_3.4.2_T17.seq* as an example. Handle the other sequences in the same way.

Test Procedure

- 1) Connect instruments and mobile station as shown in Fig. 5_3.
- 2) Run CMUgo, and then click *Configuration, Configure Tests*. The *Configure Test* window opens.
- 3) Click *Load Sequence*, and select *CDMA2000_3.4.2_T17.seq*.

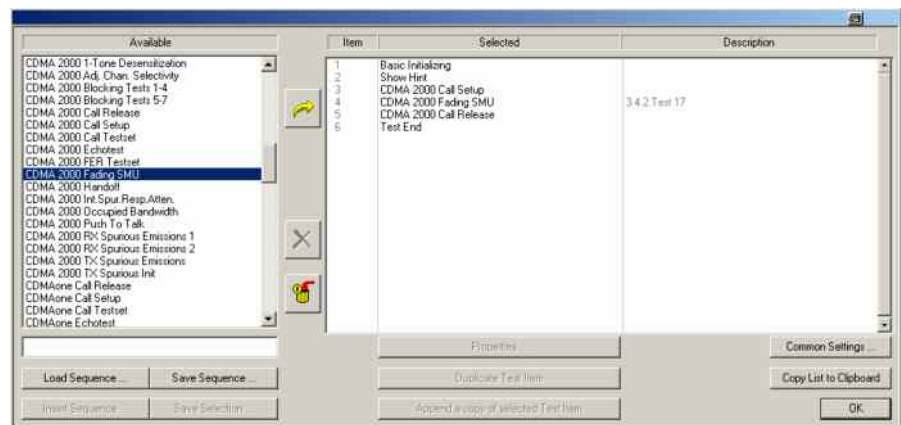

Fig. 5_6: Available and selected test items (test sequence) for the *demodulation of forward fundamental channel in multipath fading channel* test.

Additional Tests on CDMA2000 Mobile Stations

Check Basic Initializing:

Check whether the correct function group inside the CMU is activated; see table below:

BC0, BC2, BC3, BC7, BC9, BC10	IS-CDMA2000 Cellular Band
BC1, BC4, BC8	IS-CDMA2000 PCS Band
BC5	IS-CDMA2000 450 MHz
BC6	IS-CDMA2000 IMT2K Band

Table 5_7: Band classes and CMU function groups

Configure test item *CDMA 2000 Call Setup*:

- 4) Double-click *CDMA 2000 Call Setup* in the list of the selected test items.

The window *Call Setup Configuration* opens.

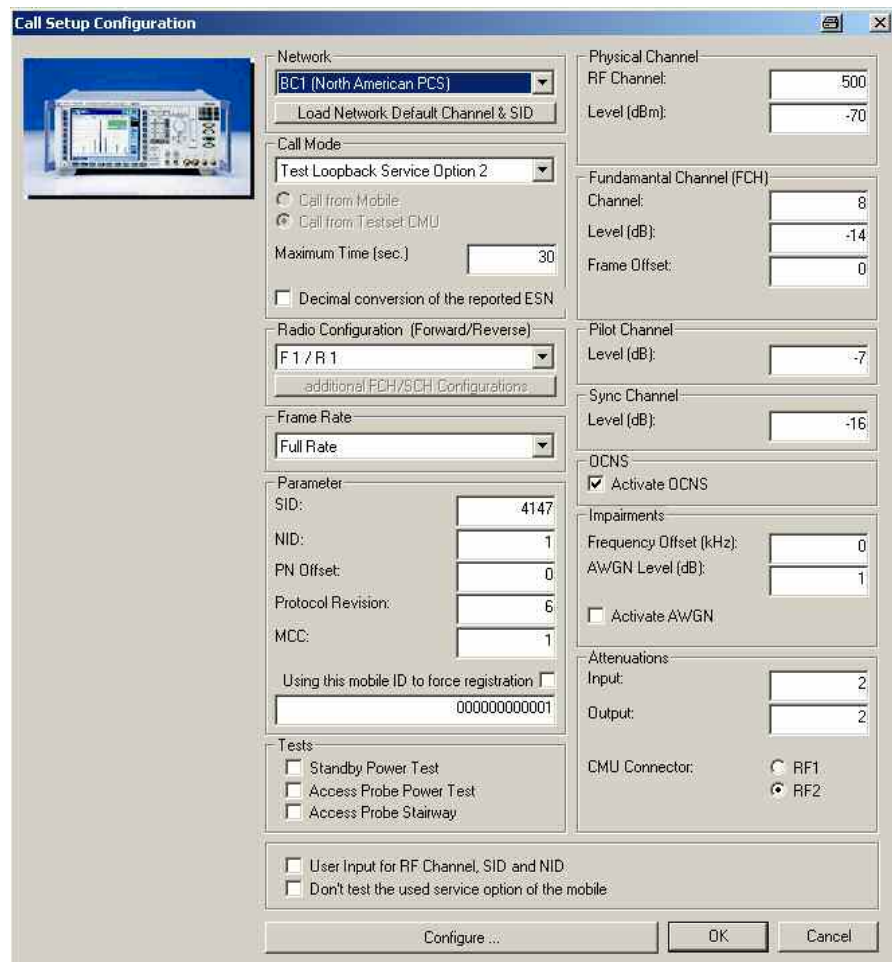

Fig. 5_8: Call setup configuration for demodulation of forward fundamental channel in multipath fading channel tests.

Additional Tests on CDMA2000 Mobile Stations

- 5) Select the *Network* corresponding to the band class (BC) of your mobile station.
- 6) Depending on the *Test Mode*, select one *Call Mode* from the service options supported by both the CMU and your mobile station (see tables 5.9 a, b):

Fundamental Channel			
Test Mode	RC of Forward Traffic Channel	RC of Reverse Traffic Channel	Call Mode (Service Option)
Test Mode 1	1	1	SO2 / SO55
Test Mode 2	2	2	SO9 / SO55
Test Mode 3	3	3	SO2 / SO55 / SO32
Test Mode 4	4	3	SO2 / SO55 / SO32
Test Mode 5	5	4	SO9 / SO55 / SO32

Table 5.9a: Test Modes, Radio Configurations and Call Modes on Fundamental Channel.

Supplemental Channel			
Test Mode	RC of Forward Traffic Channel	RC of Reverse Traffic Channel	Call Mode (Service Option)
Test Mode 3	3	3	SO32
Test Mode 4	4	3	SO32
Test Mode 5	5	4	SO32

Table 5.9b: Test Modes, Radio Configurations and Call Modes on Supplemental Channel.

- SO2: Loopback Service Option 2
 SO9: Loopback Service Option 9
 SO55: Loopback Service Option 55
 SO32: Test Data Service Option

Notes: Dedicated Control Channel Test Modes are currently not supported by the CMU200.

Supplemental Code Channel Test Mode 1 / 2 is currently not supported by the CMU200.

- 7) Select your *Radio Configuration (Forward / Reverse)* combination.
- 8) Enter a channel number for the call setup at *Physical RF Channel*.
- 9) Enter the path loss you measured between the MS and the CMU200 as *Input Attenuation* and *Output Attenuation*.
- 10) Make sure that OCNS is activated.

You may modify the other parameters if necessary.

11) Click OK.

You are back in the *Configure Test* window (Fig. 5_5):

Configure test item *CDMA 2000 Fading SMU*:

1) Double-click *CDMA 2000 Fading SMU* in the list of the selected test items.

The CDMA2000® fading window appears (see Fig. 5_10).

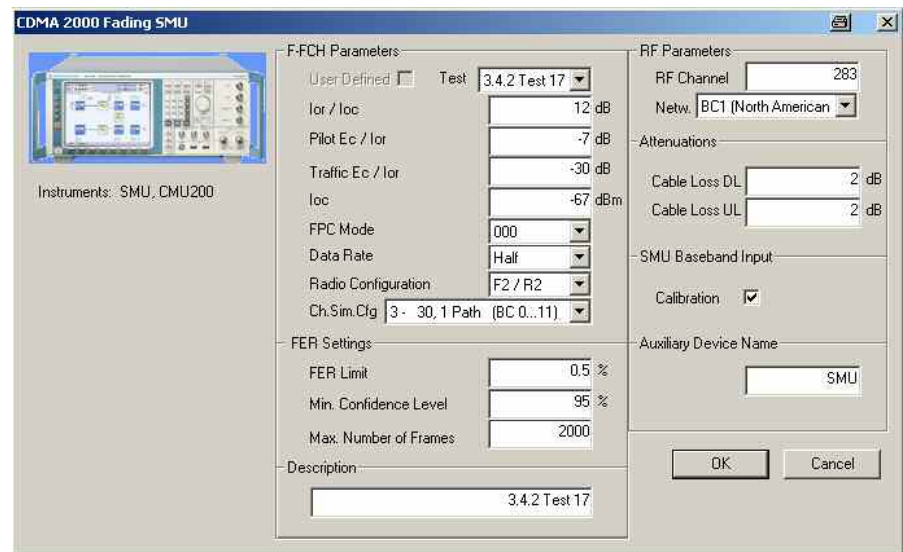

Fig. 5_10: The generic CDMA2000® window for *demodulation in multipath fading*.

The CDMA2000® fading window can be used for the test numbers 3.4.2, 3.4.7, 3.4.8, and 3.4.9.

2) Select your *Network (Band Class)*,

3) Select one *Test*.

Once the bandclass and a test are selected most of the parameter entries in the window above are preset with predefined values from standard TIA-98 such as the signal parameters \hat{I}_{or} / I_{oc} , $Pilot E_c / I_{or}$, $Traffic E_c / I_{or}$, the *Data Rate*, the *Channel Simulator Configuration*, and the *FER Limit*. If you modify one or more of these parameters, "User" will be indicated in the checkbox beside the test select field.

4) Modify these parameters if necessary.

Listed below are some of the remaining parameters:

5) Enter a *Confidence Level* and the *Number of Frames*.

6) Enter a channel number at *RF Channel*.

Additional Tests on CDMA2000 Mobile Stations

- 7) Enter the path loss you measured between the MS and the CMU200 as *Cable Loss DL* and *UL*.
- 8) **Enable the *SMU Baseband Input Calibration* checkbox in the item *CDMA2000 Fading SMU* which follows immediately after *CDMA 2000 Call Setup* in your test sequence.** The SMU will then measure the incoming baseband signal and adjust the AWGN correctly. This calibration remains valid for all following test items.
- 9) Add a comment in the *Description* field if you like.
- 10) Click *OK*.

You are back in the *Configure Test* window (Fig. 5_5).

- 11) Configure another item. If necessary, create your own sequence.

You may want to store your sequence. Use the *Save Sequence* button in the *Configure Test* window (see Fig. 5_5).

- 12) Finally click *OK* (in the *Configure Test* window).

This completes the measurement setup.

To start the measurement:

Click the start icon in the menu bar of CMUgo:

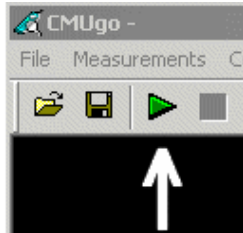

Fig. 5_11: Start icon in the menu bar of CMUgo

To stop a running measurement:

- Click the stop icon in the menu bar of CMUgo:

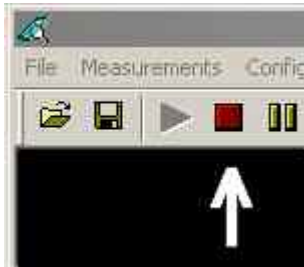

Fig. 5_12: Stop icon in the menu bar of CMUgo

Test description and measurement report:

Additional Tests on CDMA2000 Mobile Stations

When the basic initialization is completed, a pop-up menu instructs you to *Switch on the Mobile*. Ignore this message if it is already powered up. After the individual response time of the mobile station, the CMU200 automatically registers the mobile station and sets up a call connection. The pop-up menu disappears when the call is established.

The sequence *CDMA2000_3.4.2_T17.seq* sets up the channel simulator configuration 3. This simulates one path, and a velocity of 30 km/h. The CMU200 starts the frame error measurement. The minimum number of frames is defined in the standard TIA-98 for the requested confidence level of 95 % as 9000 frames. With a frame length of 20 ms, the measurement lasts 180 seconds. For a first orientation, fewer frames could be taken. (In the test sequences, the number of frames is set to 2000.)

Once the test has been completed, you get a display similar to Fig. 5_13.

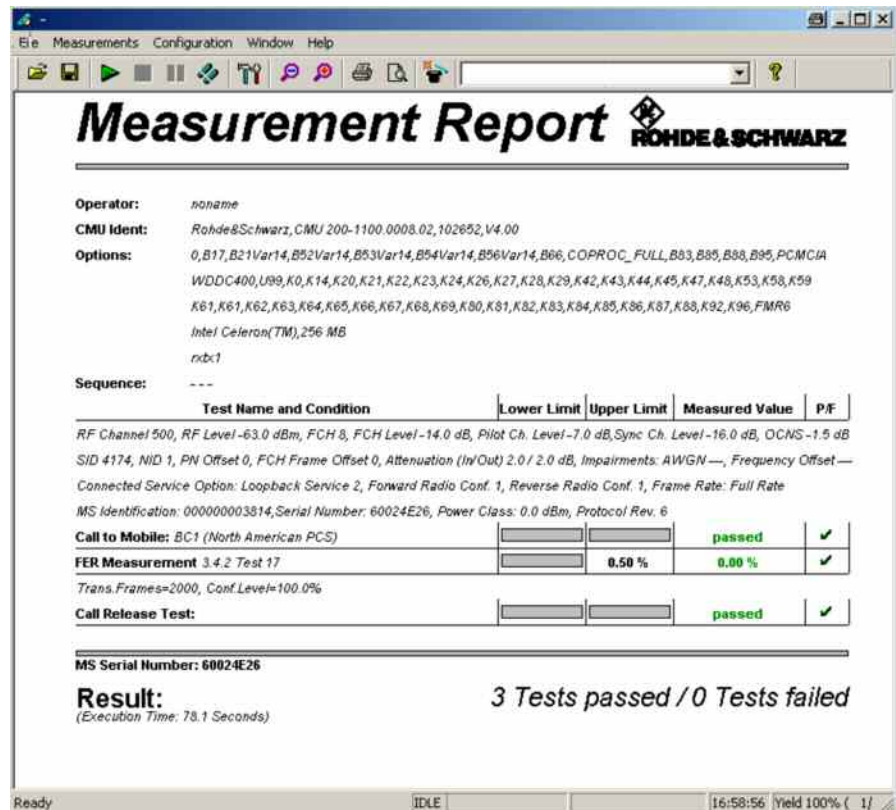

Fig. 5_13: Result for demodulation of forward fundamental channel in multipath fading channel test.

Measurement values that are inside the limits are displayed in green; those outside the limits are displayed in red. In addition, the right-hand column (P/F, for Pass/Fail) indicates whether a test was passed or failed. You see the number of frames, and the actual confidence level that was reached for this measurement.

Note: A test result which seems to be inside the limits (e.g. BER = 0%) could be displayed in red colour as failed, if the confidence level specified in the test item could not be reached. This could happen if the number of frames you entered was too low.

If your sequence contains more than one test item, each one provides a single test result. The total number of passed and failed tests are counted inside CMUgo and presented by the item *Test End*.

As another example, Fig. 5_14 shows the result of sequence *CDMA2000_3.4.2_T17_Char.seq*.

This sequence reveals the input characteristic of the mobile receiver: \hat{I}_{or} / I_{oc} has to be greater than 6 dB for a frame error rate below 0.5 %.

Additional Tests on CDMA2000 Mobile Stations

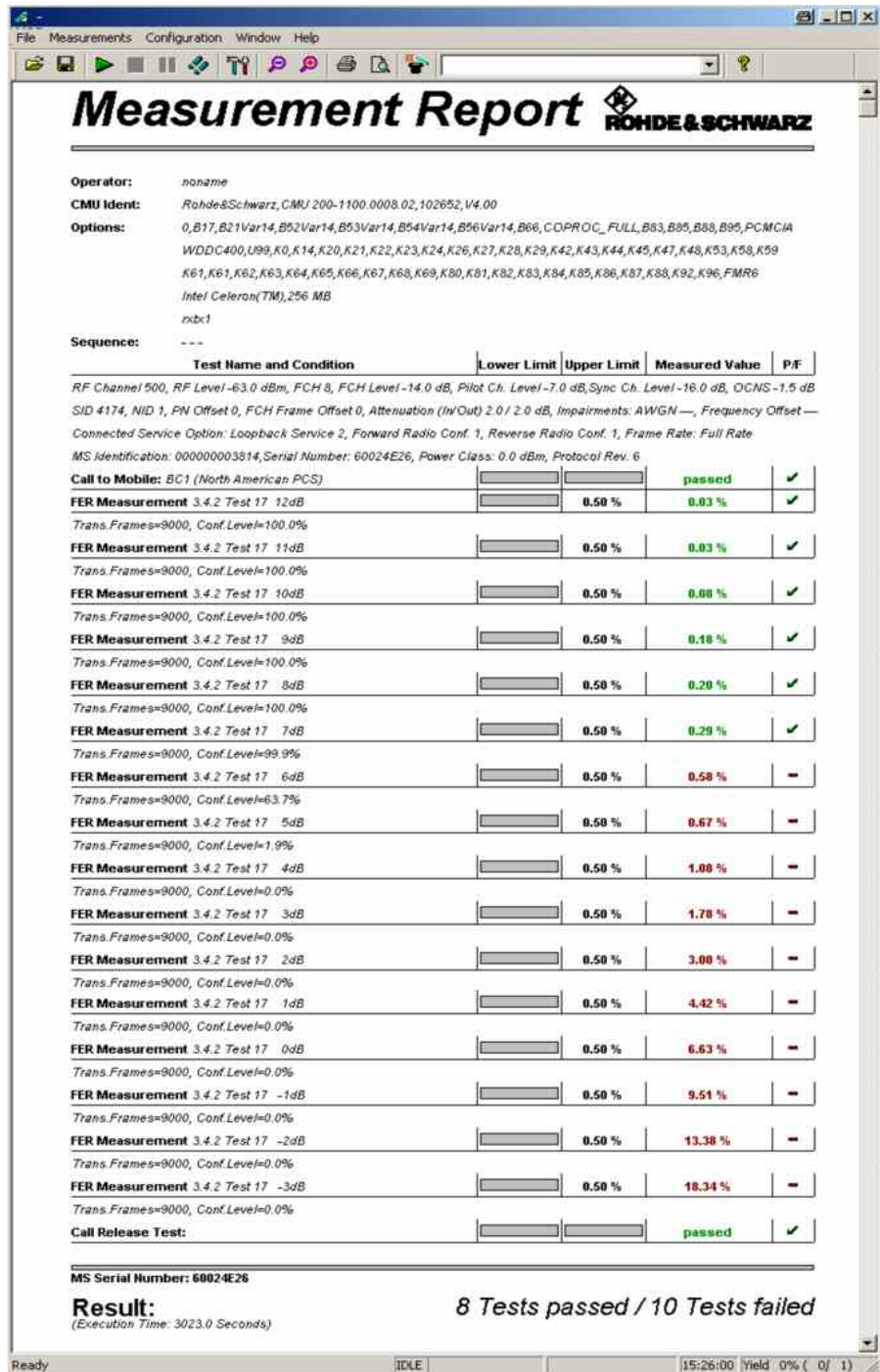

Fig. 5_14: Test CDMA2000_3.4.2_T17_Char.seq shows the receiver input characteristic.

If the call connection between the mobile station under test and the CMU200 has broken, CMUgo pops up a message box to inform you and skips the rest of the tests.

To repeat a test sequence, click the start button again (Fig. 5_11).

If your mobile station supports more than one band class, change the configurations accordingly and start the test sequence again.

4 Transmitter Tests

4.5.1: TX Conducted Spurious Emissions

TX conducted spurious emissions are spurious emissions at frequencies that are outside the assigned CDMA channel.

The emissions are measured during continuous TX transmission with a spectrum analyzer connected to the mobile station antenna port.

The purpose of test 4.5.1 is to verify that the emissions of the mobile station do not exceed a specific set of limits.

This test is performed for each band class the mobile stations supports.

Recommended test setup:

Fig. 4.5.1_1 shows the test setup for the TX conducted spurious emissions.

The RF ports of the Radio Communication Tester CMU200 and the mobile station under test are connected by means of a resistive combiner. During the test, a call is set up to the mobile station and a connection is established by CMU using this path. In addition, a spectrum analyzer is coupled in to measure the spurious emissions. The resistive combiner ensures a flat frequency response.

Both the CMU and the spectrum analyzer are remote-controlled by CMUgo to run the test automatically.

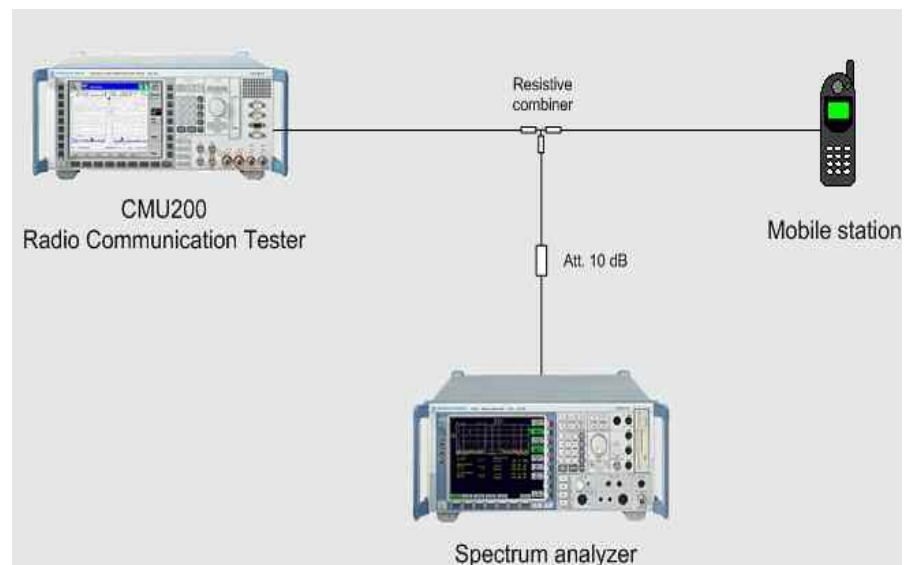

Fig. 4.5.1_1: Test setup for TX conducted spurious emission test

Instruments and accessories:

- CMU200, FSQ, FSU, FSP or FSL
- Resistive combiner (recommended: Weinschel 1515-1, DC to 12.75 GHz)

Additional Tests on CDMA2000 Mobile Stations

Path loss compensation:

(see previous section)

- Measure the path loss between the MS and the CMU200
- Measure the path loss between the MS and the spectrum analyzer

Test procedure:

- 1) Connect instruments and mobile station as shown in Fig. 4.5.1_1.
- 2) Run CMUgo, and then click *Configuration, Configure Tests*.

The *Configure Test* window opens.

- 3) Click *Load Sequence*, and select *CDMA2000_4.5.1.seq*.

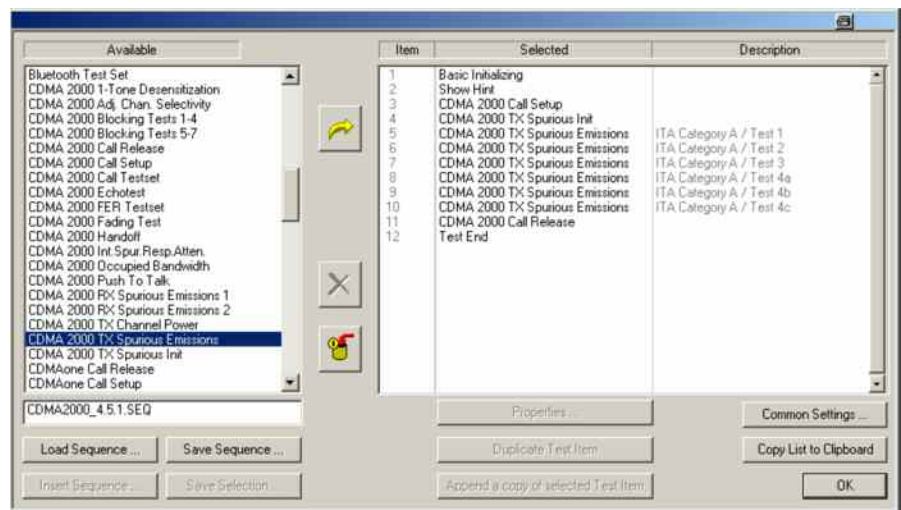

Fig. 4.5.1_2: Available and selected test items (test sequence) for TX conducted spurious emissions.

The sequence *CDMA2000_4.5.1.seq* contains as an example the test suite in accordance with ITU specification / Category A.

Test item *CDMA 2000 TX Spurious Init* causes the CMU to continuously send '0' power control bits to the mobile station. This sets the mobile station's output power to maximum. Test item *CDMA 2000 TX Spurious Init* has no parameter window.

First check Basic Initializing

Check whether the correct function group inside the CMU is activated (see table 4.5.1_3).

BC0, BC2, BC3, BC7, BC9, BC10	IS-CDMA2000 Cellular Band
BC1, BC4, BC8	IS-CDMA2000 PCS Band
BC5	IS-CDMA2000 450 MHz
BC6	IS-CDMA2000 IMT2K Band

Table 4.5.1_3: Band classes and CMU function groups.

Configure test item *CDMA 2000 Call Setup*:

- 1) Double-click *CDMA 2000 Call Setup* in the list of the selected test items.

The window *Call Setup Configuration* opens.

The screenshot shows the 'Call Setup Configuration' dialog box with the following settings:

- Network:** BC1 (North American PCS)
- Call Mode:** Test Loopback Service Option 2
- Radio Configuration (Forward/Reverse):** F 1 / R 1
- Parameter:** SID: 1, NID: 1, PN Offset: 0, Protocol Revision: 6, MCC: 1
- Physical Channel:** RF Channel: 500, Level (dBm): -70
- Fundamental Channel (FCH):** Channel: 8, Level (dB): -7.4, Frame Offset: 0
- Pilot Channel:** Level (dB): -7
- Sync Channel:** Level (dB): -16
- OCNS:** Activate OCNS
- Impairments:** Frequency Offset (kHz): 0, AWGN Level (dB): 1
- Attenuations:** Input: 6.8, Output: 6.8
- CMU Connector:** RF2
- Tests:** Standby Power Test, Access Probe Power Test, Access Probe Stairway
- User Input for RF Channel, SID and NID:** User Input for RF Channel, SID and NID
- Don't test the used service option of the mobile:** Don't test the used service option of the mobile

Fig. 4.5.1_4: Call setup configuration for TX Conducted Spurious Emissions test.

Depending on the *Call Mode* you selected, the configuration window provides a set of *Radio Configuration* combinations.

- 2) Select your *Radio Configuration (Forward/Reverse)* combination.
- 3) Enter a channel number for the call setup at *Physical RF Channel*.
- 4) Enter the path loss you measured between the MS and the CMU200 as *Input Attenuation* and *Output Attenuation*.

You may modify the other parameters if necessary.

- 5) Click *OK*.

Additional Tests on CDMA2000 Mobile Stations

You are back in the *Configure Test* window (Fig. 4.5.1_2):

Configure test items **CDMA 2000 TX Spurious Emissions:**

- 1) Double-click *CDMA 2000 TX Spurious Emissions* in the list of the selected test items.

The window *CDMA2000 TX Spurious Emissions* appears (see Fig. 4.5.1_5).

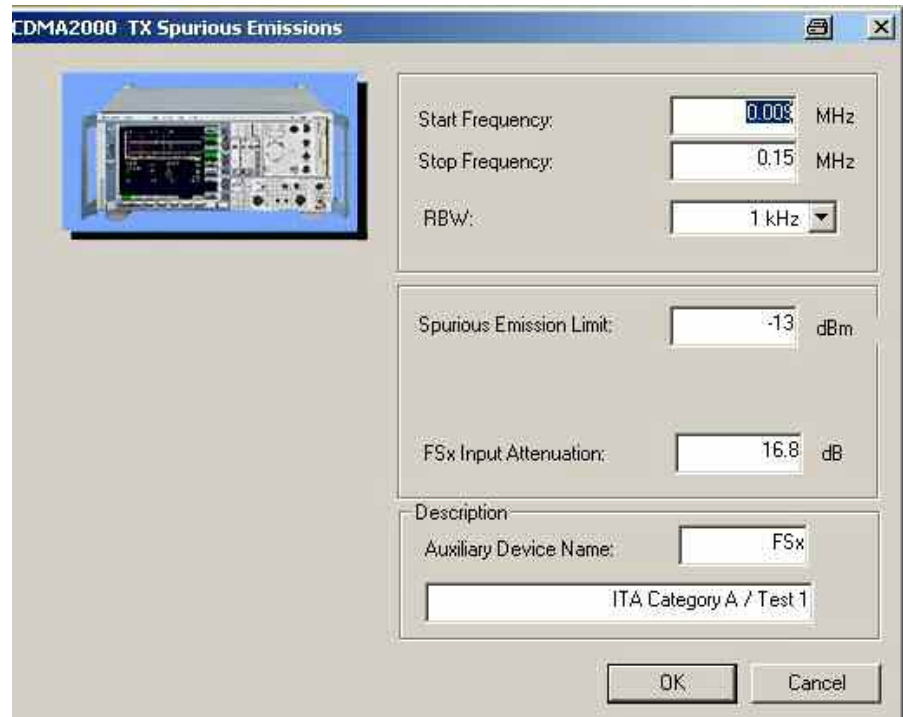

Fig. 4.5.1_5: Setup example for CDMA2000[®] TX conducted spurious emissions.

Predefined parameters are the *Start and Stop Frequencies*, the resolution bandwidth *RBW*, and the *Spurious Emission Limit*.

If you modify one of these entries, the selection changes to *User defined*.

- 2) Select your test.
- 3) Modify parameters if necessary.

Listed below are some of the remaining parameters:

- 1) Enter the path loss you measured between the MS and the spectrum analyzer as *FSx Input Attenuation*.
- 2) Enter as *Auxiliary Device Name* the name you specified for the analyzer's GPIB configuration (see section *Configuring the GPIB settings* on page 6).
- 3) Add a comment if you like.
- 4) Click *OK*.

You are back in the *Configure Test* window (Fig. 4.5.1_2).

Additional Tests on CDMA2000 Mobile Stations

- 5) Configure the next test item, e.g. the first out-of-band.
- 6) If necessary, create your own sequence.

You may want to store your sequence. Use the button *Save Sequence* in the *Configure Test* window (see Fig. 4.5.1_2).

- 7) Finally click *OK* (in the *Configure Test* window).

This completes the measurement setup.

To start the measurement:

- Click the start icon in the menu bar of CMUgo (see Fig. 3.5.2_7).

Test description and measurement report:

When the basic initialization is completed, the specified sections of the spectrum are scanned one after the other. For each section scanned, the maximum measured value is stored in CMUgo.

Once all test steps have been completed, you get a display similar to Fig. 4.5.1_6.

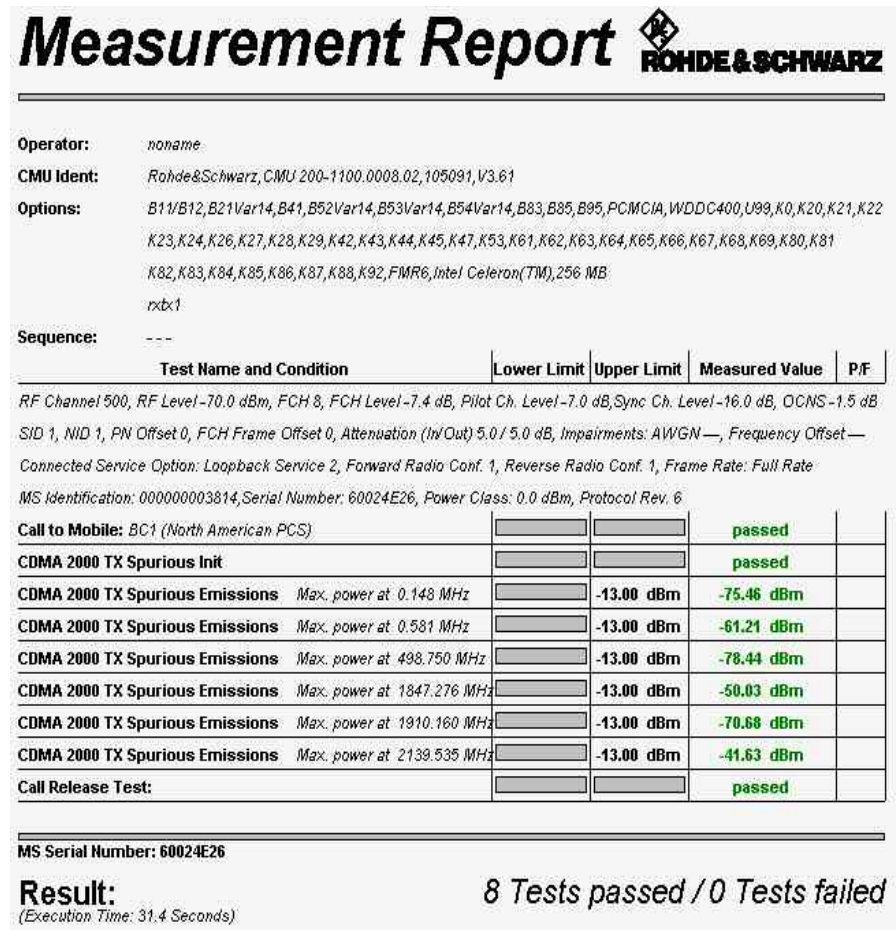

Fig. 4.5.1_6: Test result for TX conducted spurious emissions.

Measurement values that are below the limits are displayed in green; those which exceed the limits are displayed in red. In addition, the right-hand column (P/F, for Pass/Fail) indicates whether a test was passed or failed.

To repeat a test sequence, click the start button again (Fig. 3.5.2_7).

If your mobile station supports more than one band class, change the configurations accordingly and start the test sequence again.

4.5.3: Occupied Bandwidth

The occupied bandwidth (OBW) is defined as the frequency range, where the fractions of the total radiated power of a modulated carrier above and below the edge frequency are 0.5 % each, averaged over the frequency.

The occupied bandwidth is measured directly by the OBW procedure of the analyzer's firmware.

The purpose of test 4.5.3 is to verify that the OBW of the mobile station does not exceed 1.48 MHz for SR 1, nor 4.6 MHz for SR 3.

This test is applicable to BC 3 and 6 mobile stations only.

Recommended test setup:

Fig. 4.5.3_1 (on page 63) shows the test setup for the occupied bandwidth test. It is the same setup that is used for test 4.5.1.

The RF ports of the Radio Communication Tester CMU200 and the mobile station under test are connected by means of a resistive combiner. During the test, a call is set up to the mobile station and a connection is established by the CMU using this path. In addition, a spectrum analyzer is coupled in to measure the OBW. The resistive combiner ensures a flat frequency response.

Both the CMU and the spectrum analyzer are remote-controlled by CMUgo to run the test automatically.

Instruments and accessories:

- CMU200, FSQ, FSU, or FSP, or FSL
- Resistive combiner (recommended: Weinschel 1515-1, DC to 12.75 GHz)

Path loss compensation:

(see previous section)

- Measure the path loss between the MS and the CMU200
- Measure the path loss between the MS and the spectrum analyzer

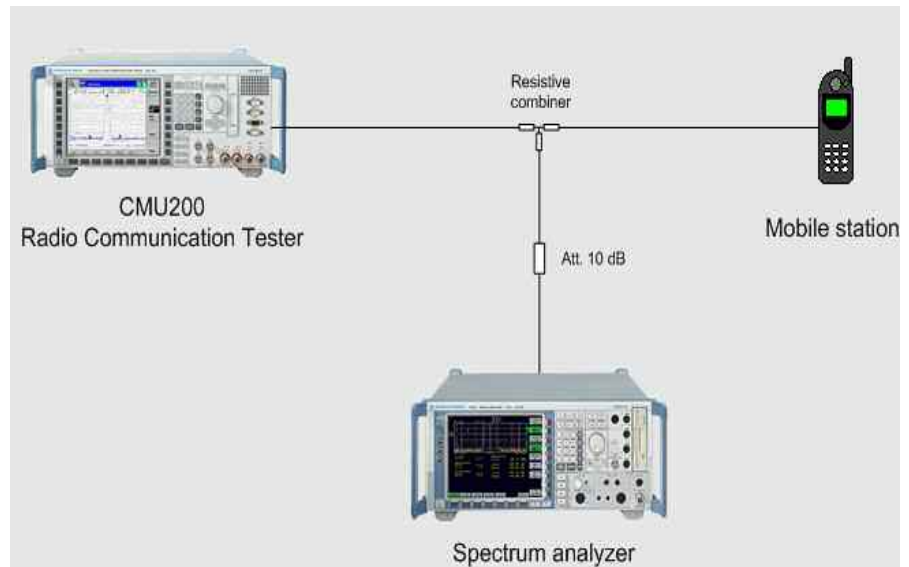

Fig. 4.5.3_1: Test setup for occupied bandwidth test.

Test procedure:

- 1) Connect instruments and mobile station as shown in Fig. 4.5.3_1.
- 2) Run CMUgo, and then click *Configuration, Configure Tests*. The *Configure Test* window opens.
- 3) Click *Load Sequence*, and select *CDMA2000_4.5.3.seq*.

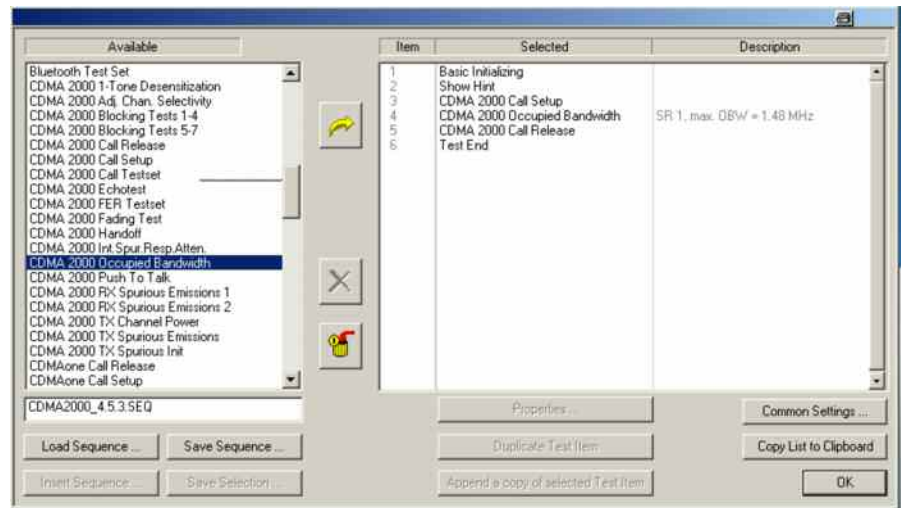

Fig. 4.5.3_2: Available and selected test items (test sequence) for occupied bandwidth.

Additional Tests on CDMA2000 Mobile Stations

Check Basic Initializing

The predefined sequence uses BC3. If you work with BC6, activate IS-CDMA2000 IMT2K Band (see table 4.5.3_3).

BC3	IS-CDMA2000 Cellular Band
BC6	IS-CDMA2000 IMT2K Band

Table 4.5.3_3: Band classes and function groups.

Configure test item *CDMA 2000 Call Setup*:

- 1) Double-click *CDMA 2000 Call Setup* in the list of the selected test items.

The window *Call Setup Configuration* opens.

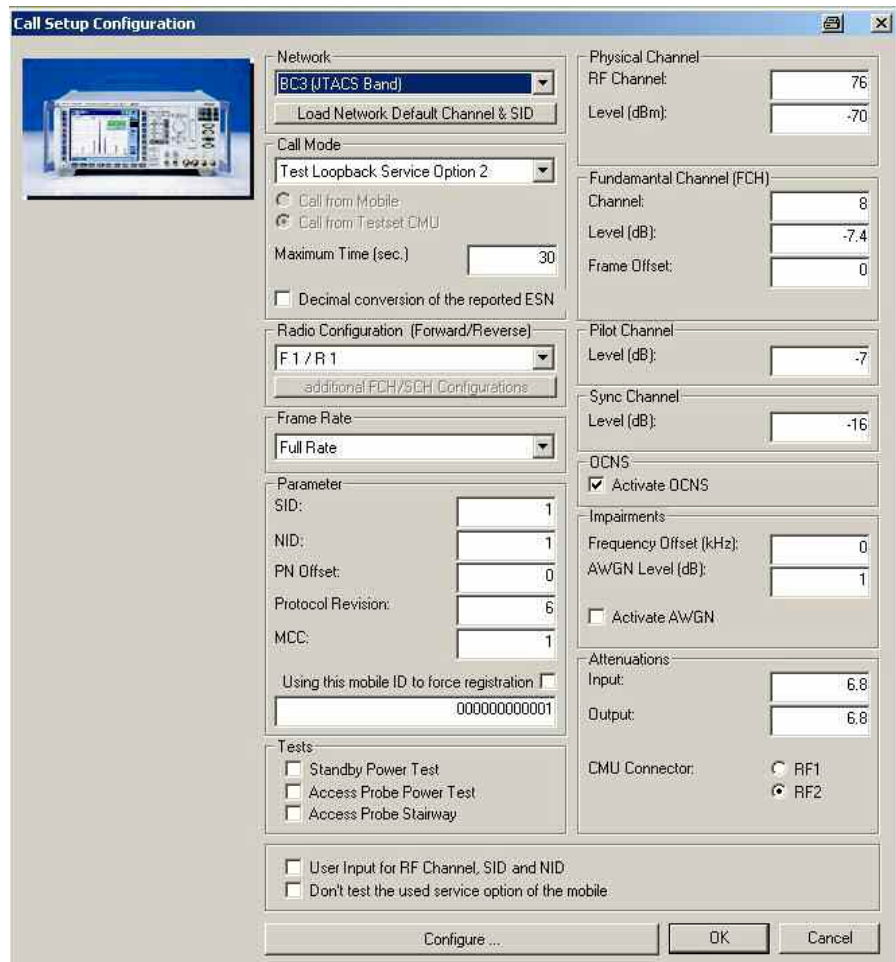

Fig. 4.5.3_4: Call setup configuration for occupied bandwidth.

Additional Tests on CDMA2000 Mobile Stations

The occupied bandwidth test is applicable to BC 3 or BC 6 mobile stations only.

- 2) Select your band class at *Network*.
- 3) Select a simple *Call Mode*, e.g. *Service Option 2* for Fundamental Channel Test Mode 1.
- 4) Select your *Radio Configuration (Forward/Reverse)* combination.
- 5) Enter a channel number for the call setup at *Physical RF Channel*.
- 6) Enter the path loss you measured between the MS and the CMU200 as *Input Attenuation* and *Output Attenuation*.

You may modify the other parameters if necessary.

- 7) Click *OK*.

You are back in the *Configure Test* window (Fig. 4.5.3_2):

Configure test item *CDMA 2000 Occupied Bandwidth*:

- 1) Double-click *CDMA 2000 Occupied Bandwidth* in the list of the selected test items.

The window *CDMA2000 Occupied Bandwidth Configuration* appears (see Fig. 4.5.3_5).

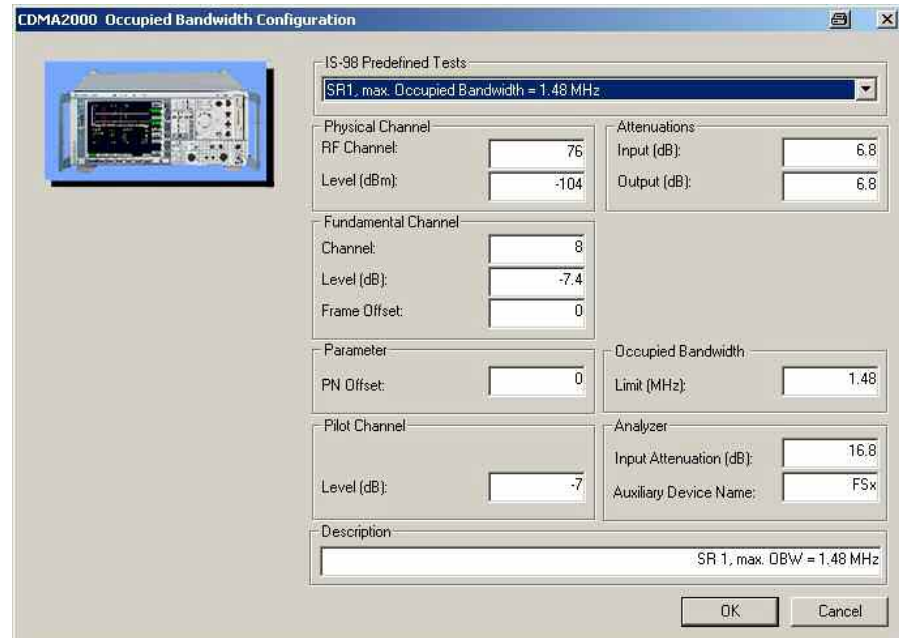

Fig. 4.5.3_5: Setup for CDMA2000[®] occupied bandwidth test.

Additional Tests on CDMA2000 Mobile Stations

Opening the pull-down list *IS-98 Predefined Tests* shows you the three available settings (see Fig. 4.5.3_6):

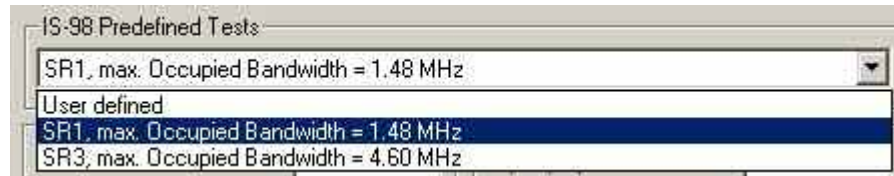

Fig. 4.5.3_6: Predefined tests for CDMA2000[®] Occupied Bandwidth

Predefined parameters are *CMU Levels*, and the *Occupied Bandwidth Limit*. If you modify one of these entries, the selection changes to *User defined*.

- 2) Select your test.
- 3) Modify parameters if necessary.

Listed below are some of the remaining parameters:

- 1) Enter a channel number at *Physical RF Channel*.
- 2) Enter the path loss you measured between the MS and the CMU200 as *Input* and *Output Attenuations*.
- 3) Enter the path loss you measured between the MS and the analyzer as *Input Attenuation* in the SMx field.
- 4) Enter as *Auxiliary Device Name* the name you specified for the generator's GPIB configuration (see section *Configuring the GPIB settings* on page 6).
- 5) Add a comment if you like.
- 6) Click *OK*.

You are back in the *Configure Test* window (Fig. 4.5.3_2).

- 7) Configure another item. If necessary, create your own sequence. You may want to store your sequence. Use the button *Save Sequence* in the *Configure Test* window (see Fig. 4.5.3_2).
- 8) Finally click *OK* (in the *Configure Test* window). This completes the measurement setup.

To start the measurement:

- Click the start icon in the menu bar of CMUgo (see Fig. 3.5.2_7).

Test description and measurement report:

When the basic initialization is completed, a pop-up menu instructs you to *Switch on the Mobile*. Ignore this message if it is already powered up. After the individual response time of the MS, the CMU200 automatically registers the mobile station and sets up a call connection. The pop-up menu disappears when the call is established.

Then the analyzer is set to the center frequency of the assigned channel, and the section that contains 99 % of the total power is evaluated. You get a display similar to Fig. 4.5.3_7.

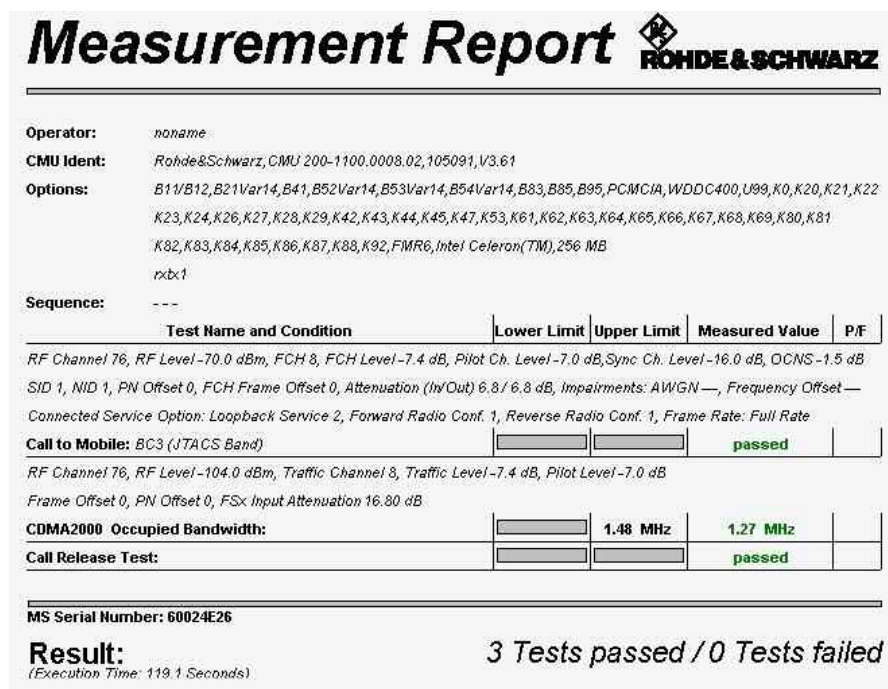

Fig. 4.5.3_7: Test result for occupied bandwidth

Measurement values that are below the limits are displayed in green; those which exceed the limits are displayed in red. In addition, the right-hand column (P/F, for Pass/Fail) indicates whether a test was passed or failed.

To repeat a test sequence, click the start button again (Fig. 3.5.2_7).

5 Summary

The program CMUgo has been enhanced by adding new test items for the CDMA2000[®] standard TIA-98. For seven tests of TIA-98 predefined test sequences are included to provide a basic parameter setting which can easily be adapted to an individual test scenario. These tests use the Radio Communication Tester CMU200 together with other instruments such as signal generators and spectrum analyzers.

For each of the tests mentioned above, the Application Note 1MA86 gives a short overview of the test itself, a recommended hardware setup, predefined test sequences, and step-by-step instructions on how to perform this test using the CMUgo software, and, finally, measurement results obtained with these predefined sequences.

For comments and suggestions to this Application Note, please contact

TM-Applications@rsd.rohde-schwarz.com.

6 References

- [1] Recommended Minimum Performance Standards for cdma2000[®] Spread Spectrum Mobile Stations, TIA-98
- [2] 3G CDMA2000 Wireless System Engineering, Samuel C. Yang, Artech House, 2004
- [3] IS-95 CDMA and cdma2000, Vijay K. Garg, Prentice Hall PTR, 1999
- [4] Generating and Analyzing cdma2000[®] Signals, Application Note 1MA34, Rohde & Schwarz, 2001

7 Ordering Information

Universal Radio Communication Testers

R&S [®] CMU200		1100.0008.02
R&S [®] CMU-K83	CDMA2000 (450 MHz)	1150.3500.02
R&S [®] CMU-K84	CDMA2000 (800 MHz)	1115.3600.02
R&S [®] CMU-K85	CDMA2000 (1900 MHz)	1115.3700.02
R&S [®] CMU-K86	CDMA2000 (2200 MHz)	1115.3800.02
R&S [®] CMU-K87	CDMA2000 Data Testing	1115.4007.02
R&S [®] CMU-K88	1xEV-DO	1115.3900.02
R&S [®] CMU-B17	I/Q-IF Interface	1100.6906.02
R&S [®] CMU-Z11	Shielded Cover	1150.1008.02

Vector Signal Generators

R&S [®] SMU200A	Vector Signal Generator	1141.2005.02
R&S [®] SMU-B102	RF Path A: 100 kHz to 2.2 GHz	1141.8503.02
R&S [®] SMU-B103	RF Path A: 100 kHz to 3 GHz	1141.8603.02
R&S [®] SMU-B104	RF Path A: 100 kHz to 4 GHz	1141.8703.02
R&S [®] SMU-B106	RF Path A: 100 kHz to 6 GHz	1141.8803.02
R&S [®] SMU-B202	RF Path B: 100 kHz to 2.2 GHz	1141.9400.02
R&S [®] SMU-B103	RF Path B: 100 kHz to 3 GHz	1141.9500.02
R&S [®] SMU-B10	Baseband with ARB (64 Msamples)	1141.7007.02
R&S [®] SMU-B11	Baseband Generator (ARB 16 MSAM)	1159.8411.02
R&S [®] SMJ-B11	Baseband Generator (ARB 16 MSAM)	1403.9009.02
R&S [®] SMU-B13	Baseband Main Module	1141.8003.02
R&S [®] SMJ-B13	Baseband Main Module	1403.9109.02
R&S [®] SMU-B14	Fading Simulator	1160.1800.02
R&S [®] SMU-B15	Fading Simulator Extension	1160.2288.02
R&S [®] SMU-K46	Digital Standard CDMA2000 incl. 1xEV-DO	1160.9876.02
R&S [®] SMJ100A	Vector Signal Generator	1403.4507.02
R&S [®] SMJ-B103	RF Path B: 100 kHz to 3 GHz	1403.8502.02
R&S [®] SMJ-K46	Digital Standard CDMA2000 incl. 1xEV-DO	1404.0605.02
R&S [®] SMJ-B10	Baseband with ARB (64 Msamples)	1403.8902.02

Additional Tests on CDMA2000 Mobile Stations

Signal Generators

R&S [®] SMR20	1 to 20 GHz	1104.0002.20
R&S [®] SMR-B11	0.01to 1 GHz	1104.4250.02
R&S [®] SMP02	2 GHz to 20 GHz	1035.5005.02
R&S [®] SMP-B11	0.01to 1 GHz	1036.6240.02
R&S [®] SML01	9 kHz to 1.1 GHz	1090.3000.11
R&S [®] SML02	9 kHz to 2.2 GHz	1090.3000.12

Baseband Signal Generator

R&S [®] AMU200A	1 to 20 GHz	1104.0002.20
R&S [®] AMU-B13	Baseband Main Module	1104.4250.02
R&S [®] AMU-B14	Fading Simulator	1402.5600.02
R&S [®] AMU-B15	Fading Simulator Extension	1402.5700.02
R&S [®] SMPxx	2 GHz to 20 GHz	1035.5005.xx
R&S [®] SMP-B11	0.01to 1 GHz	1036.6240.02
R&S [®] SML0x	9 kHz to 2.2 GHz	1090.3000.xx

Signal Analyzers, Spectrum Analyzers and Options

R&S [®] FSPxx	9 kHz to 40 GHz	1093.4495.xx
R&S [®] FSQxx	20 Hz to 26,5 GHz	1155.5001.xx
R&S [®] FSUxx	20 Hz to 46 GHz	1166.1660.xx
R&S [®] FSLxx	9 kHz to 18 GHz	1300.2502.xx
R&S [®] FSL-B22	RF Preamplifier	1300.5953.02
R&S [®] FSP-B9	Internal Tracking Generator	1129.6991.02
R&S [®] FSU-B9	Internal Tracking Generator	1142.8994.02
R&S [®] FSP-B10	External Generator Control	1129.7246.02



ROHDE & SCHWARZ

ROHDE & SCHWARZ GmbH & Co. KG · Mühldorfstraße 15 · D-81671 München · P.O.B 80 14 69 · D-81614 München ·
Telephone +49 89 4129 -0 · Fax +49 89 4129 - 13777 · Internet: <http://www.rohde-schwarz.com>

This Application Note and the supplied programs may be used only in accordance with the conditions of use set forth in the download area of the Rohde & Schwarz website.