

**Active in chemical and material fields
Suitable for semiconductor evaluation**



- High resolution of 5½-digit display
- Micro current measurement: 1fA to 19.9999mA
- High-resistance measurement: $3 \times 10^{17}\Omega$ (current function)
- Voltage source: $\pm 1\text{mV}$ to $\pm 1000\text{V}$
- High-speed measurement: up to 1000 readings/sec
- Floating measurement of 1000V (5450)
- Temperature and humidity measurement (with the optional accessory)
- Preset function for easy measurement condition setting
- Sequence program for routine measurement

GPIB USB BCD
Factory option

Ultra High Resistance Measurement

Leak Current Measurement

High-Speed Measurement

$3 \times 10^{17}\Omega$

Maximum

1 fA

Resolution

1000

Readings/sec



New Standard of Insulation Resistance and Micro Current Measurement

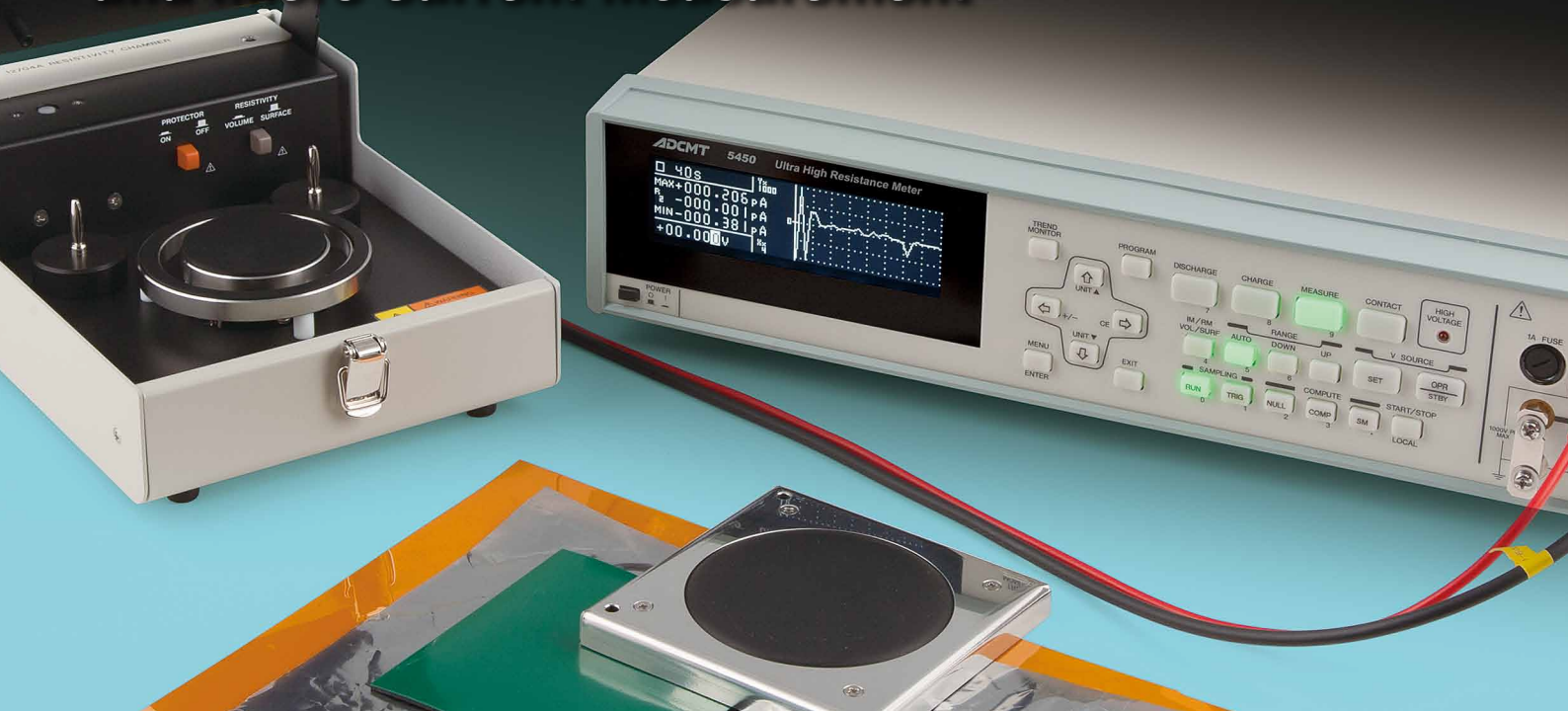

The 5450/5451 is a state-of-the-art ultra high resistance meter with 5½-digit display that integrates ADC's traditional technologies and new DC amplifier technologies. It was designed for ease of use so that anybody who operates this instrument can get the same measurement results. The 5450/5451 will be the new standard for insulation resistance measurement or micro current measurement of various kinds of insulating materials or semiconductors.

High Performance/High Speed

The 5450/5451 is ten times or more high performance than the conventional models. For example, the current measurement resolution is 1 fA, the high resistance measurement range is $3 \times 10^{17} \Omega$, the voltage to be applied to DUTs is up to $\pm 1000V$, the measurement speed is 1000 readings per second and the memory capacity for measurement results is 65000 data.

In addition, temperature and humidity can be measured at the same time with insulation resistance by using the optional accessory.

Easy to Use

The 5450/5451 is equipped with the preset function to set measurement conditions separately for each target device, the sequence program to always perform the same measurement, and the graphical display function to measure visually transient current of capacitive DUTs.

Automatic System

The 5450/5451 adopts the GPIB and the USB as standard interface and the BCD output optionally. In addition, the handler interface and the analog output are available to synchronize with other automatic devices.

Such a high-performance instrument, 5450/5451 is used in testing of secondary cell and semiconductor materials or testing of electronic parts such as capacitors and print-circuited boards. In addition, it can be used in various usages for insulating materials such as synthetic resins and rubbers from R&D, manufacturing to quality inspection fields.

Especially in testing of insulating materials, surface resistivity and volume resistivity measurement conforming to JIS (Japanese Industrial Standards) are available by using the various types of fixtures in combination.

For micro current measurement, leak current of a semiconductor device at high-voltage application can be measured with high sensitivity and at high speed.

The 5451 is provided with floating measurement capability up to 46 V peak. However, to test securely a DUT that is grounded at one side, the 5450 that is capable of floating measurement up to 1000 V peak is the best.

Flexible High Performance Measurement $3 \times 10^{17} \Omega$ and 1fA, Voltage Source $\pm 1000V$

High-Speed and High-Performance

The 5450/5451 is a high-performance meter capable of measuring micro current from 1fA to 19.9999mA and high resistance up to $3 \times 10^{17} \Omega$ (in current function). In addition, with its high-speed sampling capability up to 1000 readings per second, the 5450/5451 is suitable for Go/No-Go test in electronic part manufacturing.

Powerful and Flexible Voltage Source

As internal voltage source, a power supply that is capable of current source and sink up to 10W at $\pm 1000V$ was newly developed. This new power supply also applies negative voltage. Thus, the 5450/5451 can not only measure p-channel and n-channel semiconductors or avalanche photo diodes (APD) that operate with reverse bias voltage, but also help capacitors to be charged or discharged quickly. In addition, by setting the current limit values at will, devices are protected from overcurrent due to breakdown in semiconductor evaluation.

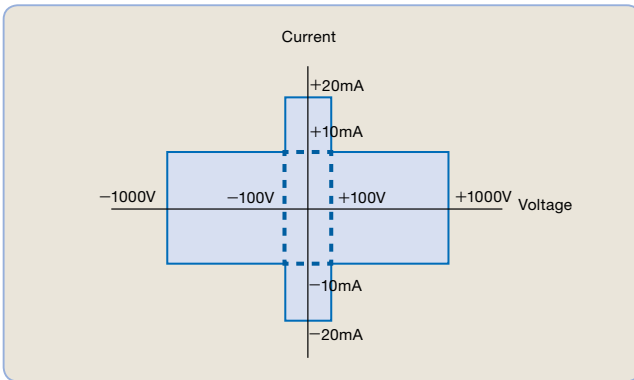

Selectable Ammeter Response

Actual ultra-high resistance measurement or micro current measurement is sometimes difficult to make under the influence of the ambient noise environment. However, a need exists for high-speed measurement in a noise-proof environment. To satisfy demands for various purposes, the 5450/5451 employs the variable gain feedback system and the response speed of the ammeter is selectable. Consequently, there is a choice between measurement highly durable against disturbance noise and high-speed measurement with quick response depending on the application or required accuracy, thus ensuring highly reliable measurement.

Ammeter response	Slow	Med	Fast	ExFast
Measurement speed	Slow	[Progressive bar]		Fast
Input resistance error	High	[Progressive bar]		Low
Noise immunity	Good	[Progressive bar]		Poor

Stable Measurement of Grounded Sample

The 5450/5451 is capable of floating measurement. The 5451 has floating measurement capability up to 46 V peak, however the 5450 up to 1000 V peak that enables a DUT grounded at one side to be measured.

Temperature and Humidity Measurement

JIS K6911 and K6723 specify temperature and humidity as test conditions for material resistivity measurement. The 5450/5451 can measure the ambient temperature and humidity by connecting the recommended temperature/humidity sensor probe.

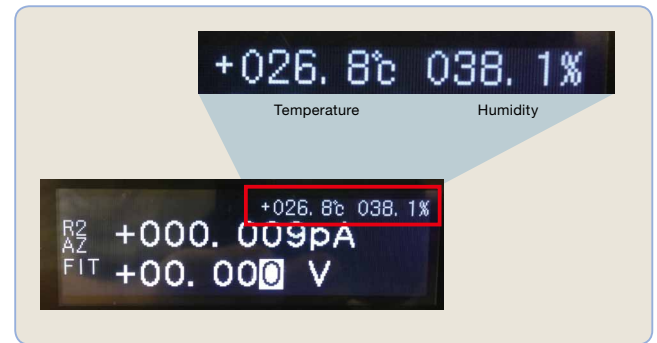

Interface Selection

In addition to GPIB and USB, the 5450/5451 is equipped with a handler interface that can control the timing with external devices such as an automatic machine in a production line. Moreover, the embedded interlock signal prevents unintended voltage output to help operators perform safety measurement.

Preset Function for Quick Operation

For ultra-high resistance or micro current measurement, the amplifier gain, the integration time and the input resistance need to be set according to its purpose. For surface or volume resistivity measurement, the electrode coefficient needs to be set. Like this, various settings are required before measurement. The 5450/5451 contains ten types of preset conditions for surface or volume resistivity measurement using the accessory, micro current measurement by pico ammeter, capacitor leak current measurement and other measurements. Thus, such a measurement can be started quickly by just selecting the preset condition without long condition settings. Of course, user parameter settings are also available.

Graphic Display, Contact Check Function and Other Various Functions Assures Consistent Measurement Results

Sequence Program Function

The order of settings or processes is important in each measurement.

The 5450/5451 has a sequence program function to store seven patterns of sequence such as order and conditions of measurements.

This function makes it possible to easily measure insulation resistance one minute after voltage application conforming to JIS. In addition, anyone can obtain the same measurement results by using the stored setting conditions.

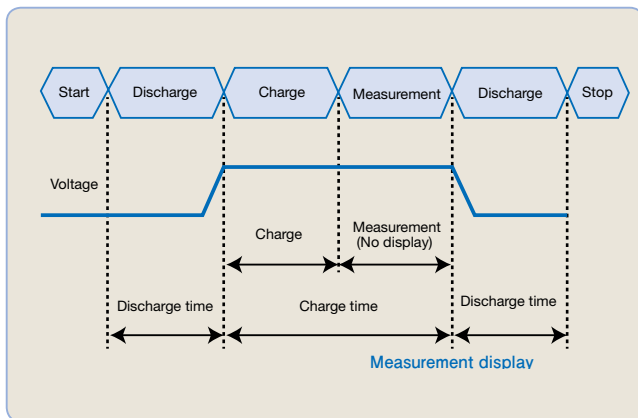

Much Safer Input Connector

When insulation resistance is measured by using floating measurement, voltage of the reverse polarity to the setting voltage is generated between the input terminal and the driving guard.

Conventional triaxial connectors are not necessarily safe because their metal parts are exposed.

The 5450/5451 adopts safer triaxial (S-Triax) connectors, securing measurement.

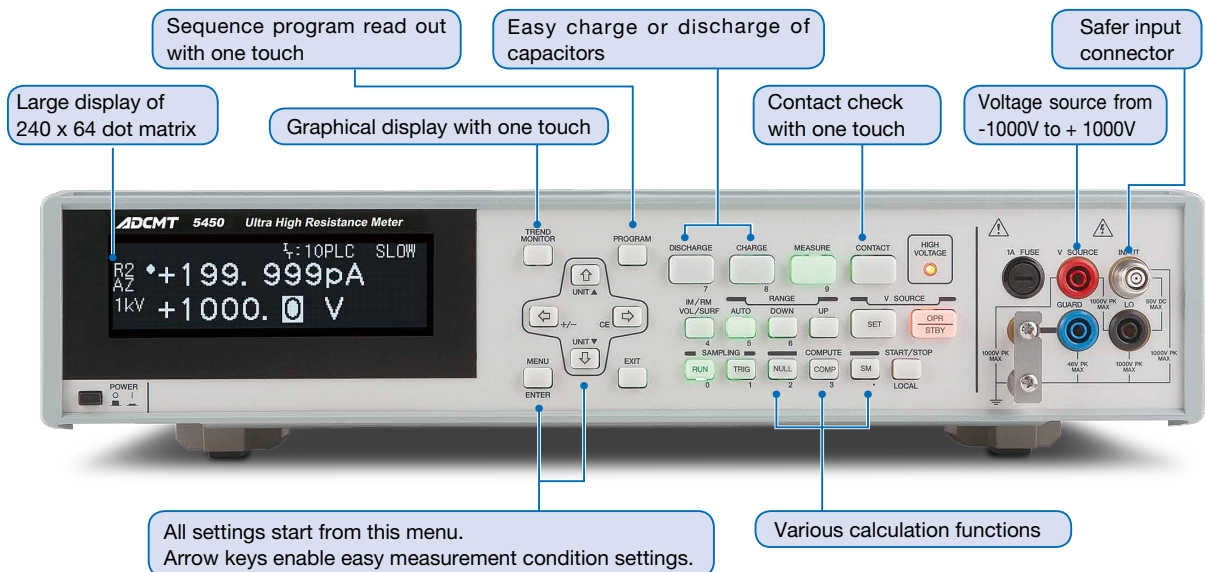
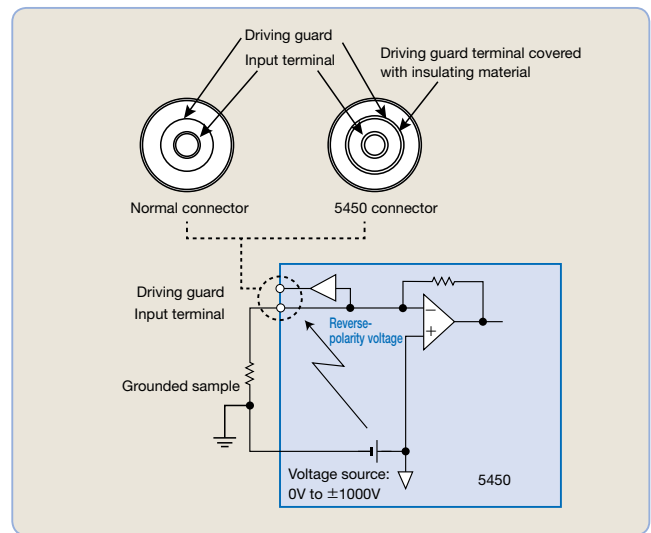

Graphical Display of Time Course

When the leak current of a capacitor is measured, right after DC voltage is applied, inrush current that is called charge current corresponding to the capacity flows then it decreases exponentially. This current is called absorption current that is caused by the time change during dielectric polarization inside the sample. A current flowing after the absorption current reaches equilibrium becomes leak current.

Here, the time it takes the absorption current to decrease exponentially and settle into equilibrium varies depending on the dielectric materials, and is sometimes very long.

To measure the leak current precisely, it is important to see if the absorption current settles down.

The 5450/5451 has a function to display the time course of measured values graphically on the dot-matrix LCD display. Thus, the measured values described above can be captured visually.

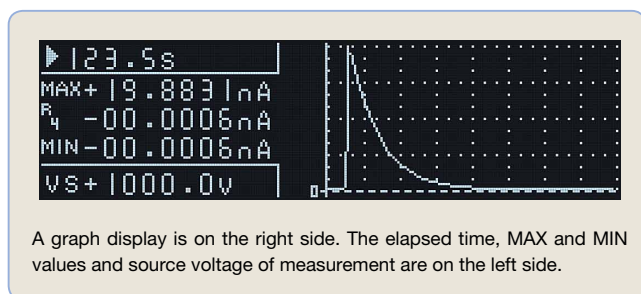

The judgment results in PASS when the capacity measured by contact check is larger than the capacity measured by Open Cal, or FAIL when it is smaller.

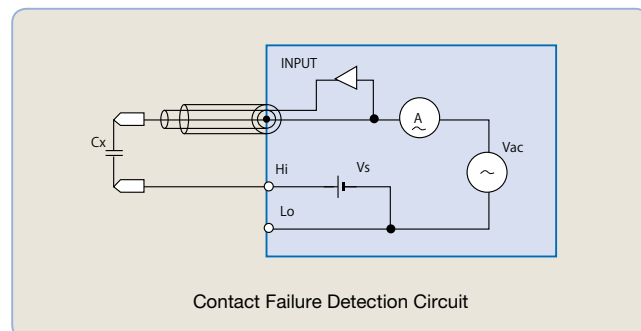

High-Speed Measurement in Auto Range

When current function measurement employs an auto range mode, high-speed device measurement is difficult because the switching time between device measurements is required, and it takes long to reach the range for a target value to be measured. Thus, to improve the takt time, a fixed range mode is normally used for measurement.

However, the upper and lower limits of an auto range can be set on the 5450/5451. Consequently, setting the minimum necessary auto range realizes the minimum switching time and improves the takt time significantly.

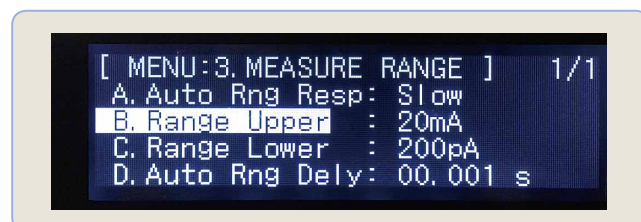

Contact Check Function

The 5450/5451 has a contact check function to detect quickly contact failures between capacitive samples (capacitors) and measurement cables or measurement electrodes. This function is executable when specified or in every measurement. Preceding Open Cal (default value measurement) cancels the capacity of the measurement cables or measurement electrodes, allowing precise contact check.

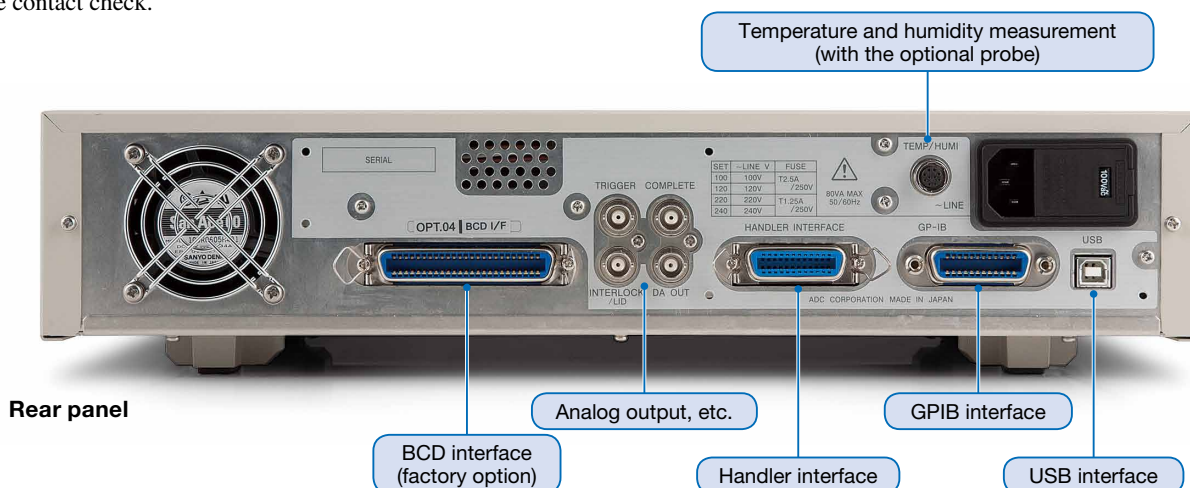

From Electronic Parts to Sheet, Film, Liquid and More JIS-Compliant High-Precision Measurement with Accessories

Condition Setting with One Touch

To measure the volume or surface resistivity of an insulating material, the electrode size needs to be set according to JIS.

The preset function of the 5450/5451 includes the default settings of typical electrode sizes that are widely used, making it simple to set measurement conditions for various insulating materials.

JIS number	Electrode size	Title
K6911	φ 50	Testing methods for thermosetting plastics
K6723	φ 70	Plasticized polyvinyl chloride compounds
C2170	φ 30.5	Methods of test for determining the resistance and resistivity of solid planar materials used to avoid electrostatic charge accumulation

Measurement with Voltage Source of ±1000V

JIS K6911 is the measurement standard for the volume or surface resistivity of insulating materials such as plastic. As for the surface resistivity measurement, it specifies that negative voltage should be applied to the ring electrode against the main electrode.

As the 5450/5451 is equipped with the bipolar voltage source that outputs both positive and negative voltage up to ±1000V, it can measure precisely the surface resistivity.

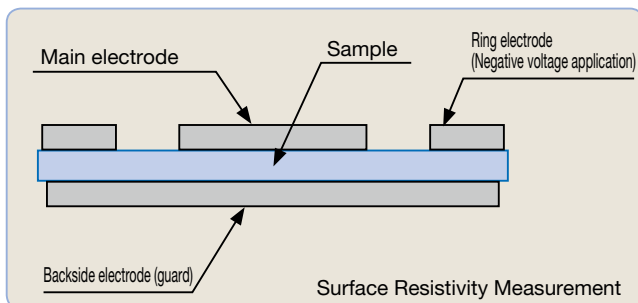

Print-Circuited Board Resistance Measurement

By using the accessory, test lead 12603, the insulation resistance of print-circuited boards can be measured.

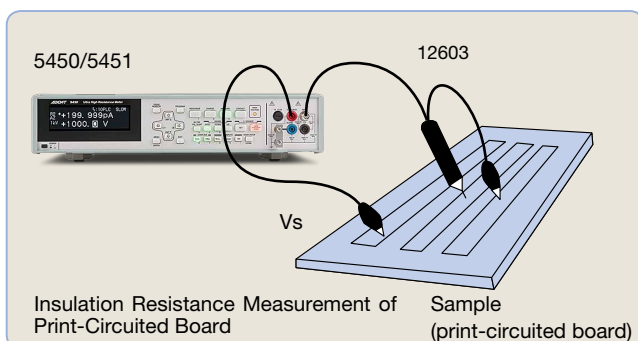

Solar Battery Leak Current (PID) Test

Solar batteries used in “Mega” solar power plants have a problem of output reduction called PID (potential-induced degradation) phenomenon in hot and humid conditions because leak current occurs in the module circuits at high voltage source.

The PID phenomenon occurs by interaction among the tempered glass on the surface, cell, back sheet and the aluminum frame of a solar battery. To evaluate this phenomenon, the leak current between the cell and frame needs to be measured.

Differently from the cell, negative voltage must be applied to the grounded frame. Thus, the 5450 capable of floating measurement of - 1000 V is the best choice.

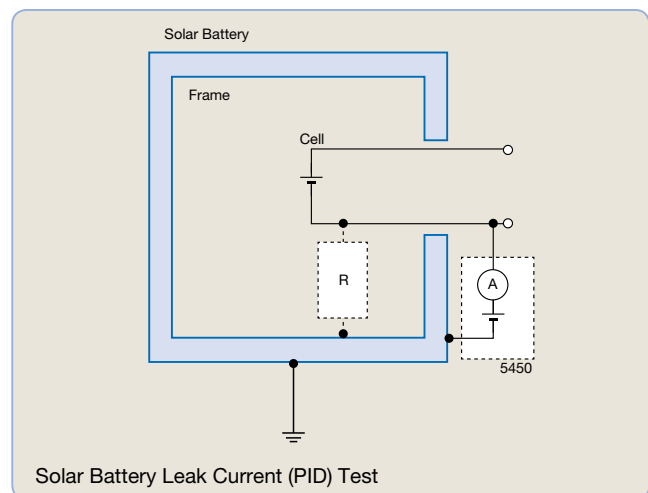

Cable Insulation Resistance Measurement

The 5450 is capable of floating measurement up to 1000 DCV. Thus, it is suitable for measuring the insulation resistance of grounded cables, transformers and so on.

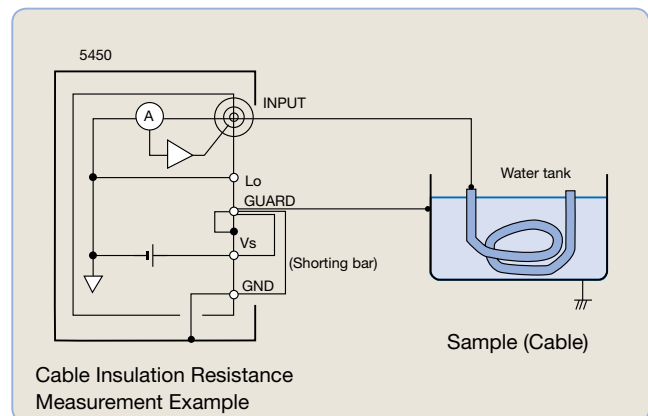

Electronic Part Evaluation System

The 5450/5451 not only performs high-speed measurement of up to 1000 readings per second, but also features the 65,000 data memory and the handler interface.

The 5450/5451 shows its excellent performance by connecting with a scanner or a handler via a PC, for example in automatic sorting of semiconductors or electronic parts.

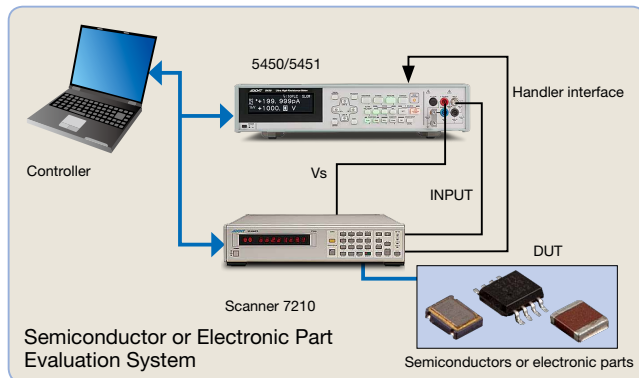

Pressure Test by Sweep Function of $\pm 1000V$

The 5450/5451 has a sequence program function that can sweep with a 4-digit setting resolution up to $\pm 1000V$. Using this function enables precise pressure test of semiconductors.

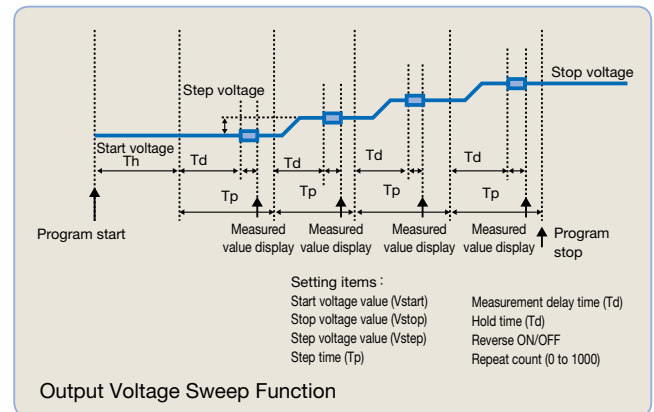

A Variety of Accessories for Research and Development of New Materials and Polymer Materials

Using the accessory resistivity chambers makes it easy to measure the volume or surface resistivity of materials. With the sequential program function and the LID signal, the 5450/5451 automatically performs discharge, charged and measurement according to the setting procedure in cover's open and close timings.

Once the measurement conditions are set, the 5450/5451 always performs the same measurement. It can prevent measurement failures due to operational mistakes to occur. Electrode coefficients necessary for volume or surface resistivity measurement can be set in addition to those of the resistivity chambers.

Purpose	Model	Exterior	Description
Sheet or film	12702A/B Resistivity chamber		For measurement of the volume or surface resistivity of sheet, filmy and play samples. The pressure to a sample is adjustable and its thickness is measurable. Thus, it is possible to measure the sample with the electrode firmly fixed by pressure.
	12704A Resistivity chamber		For measurement of the volume or surface resistivity of sheet, filmy and play samples. Adhesion with a sample is excellent because all electrodes use conductive rubber. One-touch switching between volume and surface resistivity measurement.
	12708 Resistivity chamber		For measurement of the volume or surface resistivity of sheet, filmy and play samples. Temperature in the range from normal temperature to +200°C can be applied to a sample.
	42 Resistivity chamber		For measurement of the volume or surface resistivity of sheet, filmy and play samples. For normal usage
Liquid	12707 Resistivity chamber for liquid sample		For measurement of the volume resistivity of liquid. It requires only 0.8cc of sample for measurement. The electrodes can be removed and cleaned easily.
Inspection	15045 series Standard resistance box		For inspection of digital electrometers. Five models available: $1 \times 10^3 \Omega$, $1 \times 10^5 \Omega$, $1 \times 10^{10} \Omega$, $1 \times 10^{11} \Omega$, $1 \times 10^{12} \Omega$

Purpose	Model	Exterior	Description
Electronic parts	12706A Test fixture		For insulation measurement or micro current measurement of electronic parts such as capacitor. Its structure takes shielding and isolation into account to allow stable measurement of low current and high resistance.
	12701A Test fixture		For current measurement of electronic parts such as semiconductor.
	12604 Tweezers probe		For insulation measurement of chip capacitors. With the tweezers-like shape, small chip components can be measured easily and efficiently.
	A08076 Shielded measurement plate		To be used with the 12604. For removing external noise. This measurement plate is shielded with Teflon, allowing measurement with low influence of induction noise.
Print-circuited board	12603 Test lead		For insulation resistance measurement and voltage or current measurement between patterns on print-circuited boards. It is suitable for measurement in which the measurement point is changed in succession. An external power supply is required for insulation resistance measurement.

For cables to connect the 5450/5451 with these accessories, refer to "Connection Cable List" on page 11.

Specifications

Unless otherwise specified, all accuracies are guaranteed for one year at a temperature of 23°C ±5°C and a relative humidity not exceeding 70%. The temperature coefficient is specified in the range between 0°C to 50°C.

Temperature coefficient: For the 4 ½-digit display, the digit error is reduced to 1/10.

DC Current Function (Current Display)

Current range	Maximum display	Resolution	5450 Accuracy ^{*1,2} ±(% of rdg+digits)	5451 Accuracy ^{*1,2} ±(% of rdg+digits)	Temperature coefficient ^{*3} ±(% of rdg+digits)/°C	Settling time ^{*4}
200pA	199.999pA	1fA	0.3 + 60 (60fA)	0.7 + 60 (60fA)	0.035 + 10 (10fA)	250ms
2000pA	1999.99pA	10fA	0.25 + 30 (300fA)	0.7 + 30 (300fA)	0.02 + 2 (20fA)	25ms
20nA	19.9999nA	100fA	0.2 + 30 (3pA)	0.3 + 30 (3pA)	0.01 + 2 (200fA)	5ms
200nA	199.999nA	1pA	0.1 + 30 (30pA)	0.3 + 30 (30pA)	0.01 + 2 (2pA)	
2000nA	1999.99nA	10pA	0.1 + 30 (300pA)	0.15 + 30 (300pA)	0.005 + 2 (20pA)	2ms
20μA	19.9999μA	100pA	0.1 + 20 (2nA)	0.15 + 20 (2nA)	0.005 + 2.5 (250pA)	
200μA	199.999μA	1nA	0.1 + 10 (10nA)	0.1 + 10 (10nA)	0.005 + 1 (1nA)	
2000μA	1999.99μA	10nA	0.1 + 10 (100nA)	0.1 + 10 (100nA)	0.005 + 1 (10nA)	
20mA	19.9999mA	100nA	0.1 + 10 (1μA)	0.1 + 10 (1μA)	0.005 + 1 (100nA)	

*1 Integration time: 10 PLC, Display digit: 5½, Auto zero: ON

*2 When the advanced setting function "input 1kΩ" is ON, 15 digits are added to the digit error.

*3 20fA/°C is added to the digit error at a temperature from 40°C to 50°C.

*4 Time to settle to the final value ±0.1% when the ammeter response is EXFAST. (Range switching time is not included)

Additional error depending on the integration time

Integration time	Display digit	Additional error ± (digits)			
		20mA range to 200nA range	20nA range	2000pA range	200pA range
500μs	4½ digits	2	10	30	50
2ms	4½ digits	2	10	30	50
1PLC	5½ digits	2	10	30	50

Noise rejection ratio (at 50/60 Hz ±0.08%)

Integration time	NMRR	Effective CMR ^{*5}
Integral multiple of 1PLC	60dB or more	120dB or more
Other	0dB	60dB or more

*5 Unbalanced impedance of 1kΩ

Input Specifications

Input resistance (maximum value)^{*6}

Current range	Ammeter response (input amplifier gain)			
	SLOW (×1)	MED (×10)	FAST (×100)	EXFAST (×10000)
200 pA	11 GΩ	1.1 GΩ	110 MΩ	10 kΩ
2000 pA	1 GΩ	100 MΩ	10 MΩ	1 kΩ
20 nA	100 MΩ	10 MΩ	1 MΩ	100 Ω
200 nA	10 MΩ	1 MΩ	100 kΩ	11 Ω
2000 nA	1 MΩ	100 kΩ	10 kΩ	2 Ω
20 μA	100 kΩ	10 kΩ	1 kΩ	1 Ω
200 μA	11 kΩ	1.1 kΩ	110 Ω	1 Ω
2000 μA	1.3 kΩ	130 Ω	13 Ω	1 Ω
20 mA	180 Ω	18 Ω	3 Ω	1 Ω

*6 When "input 1kΩ" is ON, 1.2kΩ is added.

Input voltage drop : ± (measuring current × input resistance + 100μV)

Input bias current : 30 fA or less

DC Current Function (Resistance Display)

Current range	Maximum display	Measurement range [Ω] ^{*10}	Accuracy	Temperature coefficient
200 pA	1 digit to 5 digits (1 to 9.9999)	5×10 ⁶ to 3×10 ¹⁷	*7 *11	*8
2000 pA		5×10 ⁵ to 3×10 ¹⁶		
20 nA		5×10 ⁴ to 3×10 ¹⁵		
200 nA		5×10 ³ to 3×10 ¹⁴		
2000 nA		5×10 ² to 3×10 ¹³		
20 μA		5×10 ¹ to 3×10 ¹²		
200 μA		5×10 ⁰ to 3×10 ¹¹		
2000 μA		5×10 ⁻¹ to 3×10 ¹⁰		
20 mA		5×10 ⁻² to 3×10 ⁹		

*7 Accuracy: ±(Accuracy 1+Accuracy 2) % of rdg

Accuracy 1 = A+B+Vi/(Vs-Vi) × 100 %^{*9}

A: Reading error of accuracy at current range for DC current function (current display) [%]

B: Setting error of accuracy at voltage source range for DC voltage source [%]

Vs: Source voltage

Vi: Input voltage drop ^{*12}

Accuracy 2 = {A/((Vs-Vi)/Rm) + B/Vs} × 100

A: Digit error of accuracy at current range for DC current function (current display) [A]

B: Digit error of accuracy at voltage source range for DC voltage source [V]

Vs: Source voltage

Vi: Input voltage drop ^{*12}

Rm: Measurement value

*8 Temperature coefficient: ±(Temperature coefficient 1 + Temperature coefficient 2) % of rdg/°C

Temperature coefficient 1 = A + B

A: Reading error of temperature coefficient at current range for DC current function (current display) [%/°C]

B: Setting error of temperature coefficient at voltage source range for DC voltage source [%/°C]

Temperature coefficient 2 = {A/((Vs-Vi)/Rm) + B/Vs} × 100

A: Digit error of temperature coefficient at current range for DC current function (current display) [A/°C]

B: Digit error of temperature coefficient at voltage source range for DC voltage source [V/°C]

Vs: Source voltage

Vi: Input voltage drop ^{*12}

Rm: Measurement value

*9 When the IV correction (input voltage drop correction) is ON, "Vi/(Vs-Vi) × 100 [%]" error is excluded

*10 When the measurement range is less than 10Ω or input resistance (IV correction: OFF), the accuracy is not guaranteed.

*11 Specified by "Vs| ≥ |Vi| + 100mV" application

*12 For how to calculate the input voltage drop, refer to the input specifications.

Resistance Function (Resistance Display)

Resistance range	Maximum display	Minimum display	Resolution	Settling time
100 kΩ	109.9 kΩ	5.0 kΩ	0.1 kΩ	Depending on current measurement range
1000 kΩ	1099 kΩ	50 kΩ	1 kΩ	
10 MΩ	10.99 MΩ	0.50 MΩ	0.01 MΩ	
100 MΩ	109.9 MΩ	5.0 MΩ	0.1 MΩ	
1000 MΩ	1099 MΩ	50 MΩ	1 MΩ	
10 GΩ	10.99 GΩ	0.50 GΩ	0.01 GΩ	
100 GΩ	109.9 GΩ	5.0 GΩ	0.1 GΩ	
1000 GΩ	1099 GΩ	50 GΩ	1 GΩ	
10 TΩ	10.99 TΩ	0.50 TΩ	0.01 TΩ	
100 TΩ	109.9 TΩ	5.0 TΩ	0.1 TΩ	
1000 TΩ	1099 TΩ	50 TΩ	1 TΩ	

(Continued from previous page) Resistance Function (Resistance Display)

Accuracy/Temperature coefficient*13

Resistance range		Source voltage						
		10V	25V	50V	100V	250V	500V	1000V
100kΩ	Current measurement range	20mA	20mA	20mA	—	—	—	—
	Accuracy	(1.3+0.003)	0.8+0.001	0.5+0.001				
	Temperature coefficient	0.12+0.0003	0.07+0.0001	0.04+0.0001				
1000kΩ	Current measurement range	2mA	2mA	2mA	20mA	20mA	20mA	—
	Accuracy	1.3+0.003	0.8+0.001	0.5+0.001	(1.3+0.003)	0.8+0.001	0.5+0.001	
	Temperature coefficient	0.12+0.0003	0.07+0.0001	0.04+0.0001	0.12+0.0003	0.07+0.0001	0.04+0.0001	
10MΩ	Current measurement range	200μA _w	200μA	200μA	2mA	2mA	2mA	20mA
	Accuracy	1.3+0.003	0.8+0.001	0.5+0.001	(1.3+0.003)	0.8+0.001	0.5+0.001	1.3+0.003
	Temperature coefficient	0.12+0.0003	0.07+0.0001	0.04+0.0001	0.12+0.0003	0.07+0.0001	0.04+0.0001	0.12+0.0003
100MΩ	Current measurement range	20μA	20μA	20μA	200μA	200μA	200μA	2mA
	Accuracy	2.3+0.005	1.3+0.002	0.8+0.001	(1.3+0.003)	0.8+0.001	0.5+0.001	1.3+0.003
	Temperature coefficient	0.27+0.0007	0.13+0.0003	0.07+0.0002	0.12+0.0003	0.07+0.0001	0.04+0.0001	0.12+0.0003
1000MΩ	Current measurement range	2μA	2μA	2μA	20μA	20μA	20μA	200μA
	Accuracy	3.3+0.008	1.7+0.003	1.0+0.002	(2.3+0.005)	1.3+0.002	0.8+0.001	1.3+0.003
	Temperature coefficient	0.22+0.0005	0.11+0.0002	0.06+0.0001	0.27+0.0007	0.13+0.0003	0.07+0.0002	0.12+0.0003
10GΩ	Current measurement range	200nA	200nA	200nA	2μA	2μA	2μA	20μA
	Accuracy	3.5+0.008	1.8+0.003	1.1+0.002	(3.3+0.008)	1.7+0.003	1.0+0.002	2.3+0.005
	Temperature coefficient	0.23+0.0005	0.11+0.0002	0.07+0.0001	0.22+0.0005	0.11+0.0002	0.06+0.0001	0.27+0.0007
100GΩ	Current measurement range	20nA	20nA	20nA	200nA	200nA	200nA	2μA
	Accuracy	3.5+0.008	1.8+0.003	1.1+0.002	(3.5+0.008)	1.8+0.003	1.1+0.002	3.3+0.008
	Temperature coefficient	0.23+0.0005	0.11+0.0002	0.07+0.0001	0.22+0.0005	0.11+0.0002	0.07+0.0001	0.22+0.0005
1000GΩ ^{*14}	Current measurement range	2nA	2nA	2nA	20nA	20nA	20nA	200nA
	Accuracy	3.9+0.008	2.2+0.003	1.5+0.002	(3.5+0.008)	1.8+0.003	1.1+0.002	3.5+0.008
	Temperature coefficient	0.24+0.0005	0.12+0.0002	0.08+0.0001	0.22+0.0005	0.11+0.0002	0.07+0.0001	0.22+0.0005
10TΩ ^{*14}	Current measurement range	200pA	200pA	200pA	2nA	2nA	2nA	20nA
	Accuracy	6.9+0.015	3.4+0.006	2.1+0.003	(3.9+0.008)	2.2+0.003	1.5+0.002	3.5+0.008
	Temperature coefficient	1.05+0.0025	0.46+0.0010	0.25+0.0005	0.23+0.0005	0.12+0.0002	0.08+0.0001	0.22+0.0005
100TΩ ^{*14}	Current measurement range	—	—	—	200pA	200pA	200pA	2nA
	Accuracy				6.9+0.015	3.4+0.006	2.1+0.003	3.9+0.008
	Temperature coefficient				1.05+0.0025	0.46+0.001	0.25+0.0005	0.23+0.0005
1000TΩ ^{*14}	Current measurement range	—	—	—	—	—	—	200pA
	Accuracy							6.9+0.015
	Temperature coefficient							1.05+0.0025

Accuracy: % of reading + % of range, Auto zero: ON

The accuracies in parentheses indicate guaranteed values by the resistance standard.

Others are calculated from DC current function (Current Display) accuracies and DC voltage source accuracies.

Temperature coefficient: % of reading + % of range

*13 Integration time: 10 PLC or longer, Auto zero: ON

*14 The accuracies in the 1000 GΩ or higher range are guaranteed at a temperature of 0° C to 40° C

DC Voltage Source

Voltage range	Source range	Setting resolution	Maximum output	Accuracy ±(% of setting + digits)	Temperature coefficient ± (% of setting + digits)/°C	Output noise (10-500Hz)
10V	0 to ±10.000V	1mV	±20mA	0.05 + 5 (5mV)	0.005 + 0.5 (0.5mV)	1mVp-p
100V	0 to ±100.00V	10mV	±20mA	0.05 + 5 (50mV)	0.005 + 0.3 (3mV)	2mVp-p
1000V	0 to ±1000.0V	100mV	±10mA	0.05 + 5 (500mV)	0.005 + 0.3 (30mV)	5mVp-p

Current limiter range	Setting range	Setting resolution	Accuracy ±(% of setting + digits)	Temperature coefficient ± (% of setting + digits)/°C
200μA	20.0μA to 200.0μA	0.1μA	0.3 + 50 (5μA)	0.01 + 10 (1μA)
2mA	0.201mA to 2.000mA	1μA	0.3 + 20 (20μA)	0.01 + 3 (3μA)
20mA	2.01mA to 20.00mA	10μA	0.3 + 10 (100μA)	0.01 + 2 (20μA)

Pure resistive load settling time*15

Voltage range	Current limiter range		
	200μA	2mA	20mA
10 V	7ms	3ms	3ms
100 V	25ms	5ms	5ms
1000 V	200ms	30ms	20ms

*15 Time to settle to 1% of the final value when changing the output from zero to full scale With the maximum setting voltage source value or limit value in each range.

Measurement Speed: DC Current Function (Current Display)

Integration time	Measurement speed	Display digit
500μsec(burst) *16	1000 readings/sec	19999
500μsec	200 readings/sec	
2msec	100 readings/sec	199999
1PLC	33 readings/sec	
5PLC	9 readings/sec	
10PLC	4.8 readings/sec	
40PLC	1.2 readings/sec	
80PLC	0.6 readings/sec	
160PLC	0.3 readings/sec	

*16 When the data memory store is set to Burst, integration time of 500μs, sampling interval of 1ms, free run, auto range OFF, calculation OFF and measurement display OFF are automatically set, allowing measurement of 1000 reading per second.

Advanced Setting Functions

- **Preset**
Ten types of parameters are preset for different applications.
- **Integration time and sampling interval**
There are eight types of integration time for A/D conversion and the sampling interval is set between 1ms and 9999.9s
- **Auto zero**
Removes the offset errors of the internal measurement circuits.
- **Input amplifier response (Input amplifier gain)**
Four levels of input amplifier gain adjust the noise immunity and the response.
- **Input resistance 1kΩ**
The input resistance 1kΩ is set to ON or OFF.
Setting to ON is recommended for stable operation for leak current or insulation resistance measurement of capacitors.
- **IV correction (Input voltage drop correction)**
Measures and corrects the input resistance error in DC current function (resistance display).
When it is set to ON, corrected voltage is displayed if valid measurement data exists.
*In resistance function (resistance display) it is always ON.
- **Auto range response**
Three levels of auto range switching speed
High-speed response measurement corresponding to the required number of digits is available.
- **Auto range delay**
Delay time to the next sampling after range change by auto range operation.
- **Range limit**
Upper and lower limits of the measurement range.
Limiting the measurement range reduces the measurement delay due to unnecessary range switching.
- **Contact check**
Function to detect contact failures of measurement samples
It is necessary for manufacturing capacitive samples such as capacitor.
Detection range: 0.5pF or more
Open Cal range: 0.5pF to 50pF
- **Sequence program**
Seven types of sequence program including JIS-compliant insulation resistance measurement that performs evaluation one minute after voltage application.

Calculation Function

- **NULL calculation** Displayed value (NULL) = Measured value - NULL constant
- **Smoothing calculation** Displayed value (SM) = Moving average of a specified number of times
- **Section average calculation** Displayed value (CAVE) = Average of a specified number of times
- **Comparator calculation** Judgment (HIGH) ← HIGH setting value < Measured value
Judgment (LOW) ← Measured value < LOW setting value
Display (GO) ← LOW setting value ≤ Measured value ≤ HIGH setting value
- **MAX/MIN/AVE calculation** Displayed value (MAX) = Maximum measured value after calculation start
Displayed value (MIN) = Minimum measured value after calculation start
Average value (AVE) = Average after calculation start
- **Integral calculation** Displayed value (Q) = (Measured current [A] × integral time [S]) of a specified number of times
- **Volume resistivity calculation** $\rho_V = (\pi d^2/4t) \times R_V$
- **Surface resistivity calculation** $\rho_S = \pi \times (D+d)/(D-d) \times R_S$

Display Functions

- **Graph display** Displays the time course of measured values on the 240 × 64 dot matrix LCD.
Charge current response and convergence can be checked visually, helping characteristic analysis of samples.

Interface Function

- **Remote command** Compliant to the ADC command system and the 8340A commands.
- **GPIB** Standard IEEE488.2
Connector Amphenol 24 pins
Interface functions SH1,AH1,T5,L4,SR1,RL1,PP0,DC1,DT1,C0,E2
Output format ASCII
Addressing 31 types of Talker and Listener addresses.
- **USB** Standard USB2.0 Full-Speed
Connector Type B
- **Handler interface** Function Input and output of synchronization signals with external devices such as auto handler
Connector Amphenol 24 pins
Input signal External trigger, contact check start, LID.
Output signal Complete output, comparator calculation result, contact check judgment result, measurement end, calculation end, alarm
Signal level Input: TTL, falling edge detection
Output: TTL, negative pulse (open collector)
- **External trigger input** Connector BNC
Signal level TTL, falling edge detection
Pulse width 100μs or more
- **Interlock/LID input** Connector BNC
Signal level TTL, rising edge and falling edge detection
- **Complete output** Connector BNC
Signal level TTL, negative pulse (open collector)
Sink current 5mA or less
Pulse width Selectable between approx. 100μs and 500μs
- **D/A output** Function Converts any 2- or 3-digit display data to analog form and outputs them.
Outputs any voltage in a range of ±1V (resolution of 1mV) (Remote only)
Connector BNC
Output voltage ±1V
Accuracy ±(0.2% + 2digit)
Output resistance 1Ω or less
Maximum load current ±0.5mA
Maximum allowable input voltage ±5V
- **BCD output (factory option)** Function Parallel output of displayed data in the BCD or binary code
OFF (all High) is selectable.
Digital output of Hi and Lo of any pins (in remote only)
Connector Amphenol 50 pins
Signal level TTL positive logic
- **Temperature and humidity sensor input** Temperature measurement range: -50° c to +100° c
Humidity measurement range: 0 to 100% RH (with the recommended temperature and humidity probe with output cable)

General Specification

- Operating environment: Temperature 0° C to +50° C
Relative humidity 85% or less without condensation

Storage environment: Temperature -25°C to +70°C
Relative humidity 85% or less without condensation

Warm-up time: 60 minutes or longer

Display: 240 × 64 dot matrix LCD

Range switching: Auto or manual

Input method: Floating

Measurement method: Integration

Over input display: OL display

Memory: Data memory: Up to 65000 data items
Condition setting memory: 4 (USER0 to USER3)

Trigger function: Internal and external triggers
External trigger: external control signal, panel key, remote (GPIB and USB)

Measurement terminal Input terminal: INPUT (5450: S.TRIAX, 5451: TRIAX)
Lo (black safety socket)
GUARD (blue safety socket, terminal block)
GND (terminal block)

Output terminal: VSOURCE (red safety socket)

Input protection fuse: 1A/250V time-lag fuse

Maximum allowable input voltage

Chassis	Input and output terminal			V SOURCE
			INPUT	
		LO	50Vdc	1000Vpeak
		1000Vpeak (46Vpeak)	1000Vpeak	1000Vpeak
GUARD		1000Vpeak (46Vpeak)	1000Vpeak	1000Vpeak
GND	46Vpeak	1000Vpeak (46Vpeak)	1000Vpeak	1000Vpeak

Voltages in parentheses are for 5451.

Maximum allowable input current: 50mApeak

Power supply: AC power supply: 100V/120V/220V/240V (user selectable)

Option Number	Standard	OPT. 32	OPT. 42	OPT. 44
Power supply voltage	100V	120V	220V	240V

Specify the option when ordering.

Use a power cable and a fuse that are compliant with the safety standard when changing the power supply voltage.

Line frequency: 50Hz/60Hz

Power consumption: 80VA or below

Dimensions: Approx. 424 (W) x 88 (H) x 350 (D) mm

Mass: 9.5kg or less

Safety: IEC61010-1, Measurement category II

EMC: EN61326 class B

Supplied accessories

Model	Quantity	Name
A01402	1	Power cable
CC010003-100*17	1	Input cable (S.TRIAX-safety)
CC010006*18	1	Input cable (TRIAAX-alligator)
CC010005	1	Output cable (safty-safety)
CC015005	*19	Alligator clip
A140001	1	Short plug

*17 : for 5450 *18 : for 5451 *19 : 2 sets for 5450 and 1 set for 5451

Optional accessories

Model	Name
CC010004-XXX*20	Input cable (S.TRIAX-high voltage TRIAX)
A01009-XXX*20	Input cable (TRIAAX-TRIAAX)
A01011-XXX*20	Input cable (TRIAAX-BNC)
A01036-1500	Input and output cable BNC-BNC 1.5m
A01044	Input and output cable safety plug
A01239-XXX*20	Input cable (high voltage TRIAX- TRIAX)
A04201	Connector (TRIAAXJ-TRIAAXJ)
A04202	Connector (TRIAAXJ-BNCP adapter 1)
A04203	Connector (TRIAAXJ-BNCP adapter 2)
A04207	Connector (BNCJ-MP)
A04208	Connector (TRIAAXJ receptacle)
A08531	Banana tip adapter for A01044
CC015003	Connector (S.TRIAX-high voltage TRIAXJ)
MI-03	BNC-alligator clip
12603, 12604	Test lead
A08076	Shielded measurement plate
127XX series	Test fixture, resistivity chamber
15045 series	Standard resistance
42	Resistivity chamber
CC028002	Front handle set (2U)
CC024002	Rack mount set (EIA 2U)
CC022002	Rack mount set (JIS 2U)

(The front handle set and the rack mount set can be used in combination.)

*20 XXX: The model changes depending on the cable length.

Recommended product

Model	Name
HC2-S-E2ACT-ADC	Temperature and humidity probe with output cable



- Please read through the operation manual carefully before using the products.
- All specifications are subject to change without notice.

Connection Cable List

Electrometer	Usage	Accessory							
		12701A	12702A/B	12704A	42	15045	12706A	12707	12708
5450 (Supplied accessory : CC010003-100, CC010005)	Input ^{*21}	A01239 + CC015003 /CC010004	A01239 + CC015003 /CC010004	A01239 + CC015003 /CC010004	A04207 + A01011 + CC015003	A01239 + CC015003 /CC010004	A01239 + CC015003 /CC010004	A01239 + CC015003 /CC010004	A01239 + CC015003 /CC010004
	Voltage application	A01044/ CC010005	A01044 + A08531/ CC010005 + A08531	A01044/ CC010005	A01044 + A08531/ CC010005 + A08531	A01044/ CC010005	A01044 + A08531/ CC010005 + A08531	A01044 + A08531/ CC010005 + A08531	A01044/ CC010005
	Inter lock	A01036-1500	—	A01036-1500	—	—	A01036-1500	A01036-1500	MI-03
5451 (Supplied accessory : CC010006, CC010005)	Input	A01009	A01009	A01009	A04207 + A01011	A01009	A01009	A01009	A01009
	Voltage application	A01044/ CC010005	A01044 + A08531/ CC010005 + A08531	A01044/ CC010005	A01044 + A08531/ CC010005 + A08531	A01044/ CC010005	A01044 + A08531/ CC010005 + A08531	A01044 + A08531/ CC010005 + A08531	A01044/ CC010005
	Inter lock	A01036-1500	—	A01036-1500	—	—	A01036-1500	A01036-1500	MI-03

*21 : When floating connection is not applied, A01009 is available instead of A01239



ADC CORPORATION

E-mail : kcc@adcmt.com URL : <http://www.adcmt-e.com>

Head Office

Shoei Bldg, 3-6-12, Kyobashi, Chuo-ku,
Tokyo 104-0031, Japan
Phone: +81-3-6272-4433 Fax: +81-3-6272-4437

Higashimatsuyama Office (R&D Center)

77-1, Miyako Namegawa-machi, Hiki-gun,
Saitama 355-0812, Japan
Phone: +81-493-56-4433 Fax: +81-493-57-1092