



## R6240A DC Voltage and Current Source/Monitor

High performance DC Voltage and Current Source/Monitor  
Pulse source with 4 A  
Pulse measurement with 500  $\mu$ s pulse width and 1  $\mu$ s resolution



# R6240A

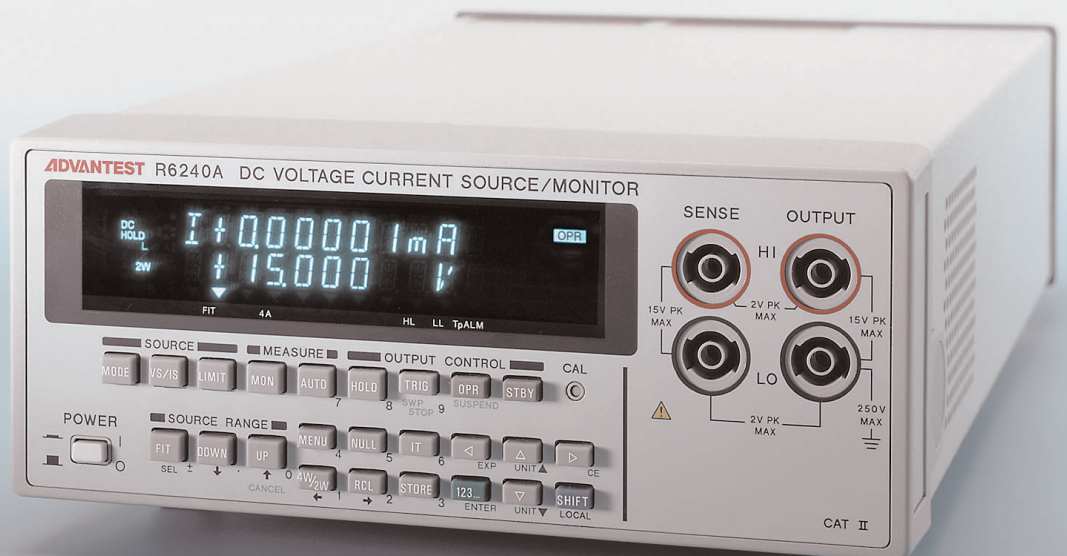

R6240A is a DC voltage and current source/monitor with high-performance features including source resolution of 4 1/2 digits, measuring accuracy of 5 1/2 digits, and basic accuracy of  $\pm 0.025\%$ . The R6240A has a pulse measuring function of pulse width of 500 $\mu$ s in addition to linear, fixed, and random sweep functions. This product can be used for a wide range of applications as a power source for evaluation in research and development of semiconductors and other electronic components, or a power source for a production line characteristic test system.

In particular, the pulse source and pulse load function with the maximum capacity of 4Amps fully demonstrates its capability in evaluation of compact devices of increasing current capacity. At the same time, the individual HI/LO limiter setting function demonstrates its power in evaluation of batteries and power source IC. The new suspend function enables selection of the optimum OFF state for each application, contributing to the throughput improvement.

- Source and measurement with the basic accuracy of  $\pm 0.025\%$
- Measuring accuracy of 5 1/2 digits ( $\pm 319999$ ), resolution of 10 $\mu$ V, and 10nA
- Source/sink of  $\pm 4$ A for a maximum period of 20ms
- Pulse measurement with minimum pulse width of 500 $\mu$ s and resolution of 1 $\mu$ s
- Linear/fixed/random sweep functions for characteristic measurement
- Individual settings of HI and LO limiters
- Suspend function that enables selection of an output OFF state
- Resistance measurement under constant voltage source or constant current source
- Synchronous measurement of multiple units

### Output range

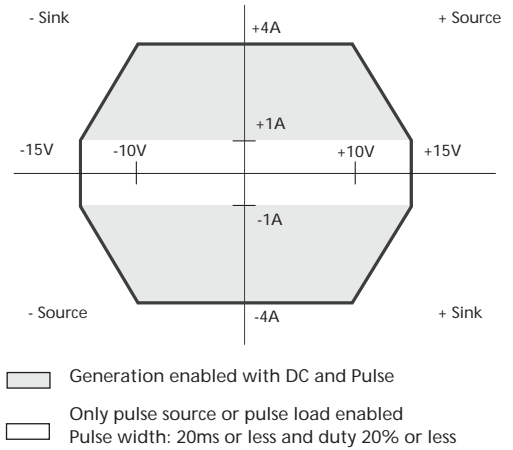

### Can generate pulse current of maximum 4A (20ms)

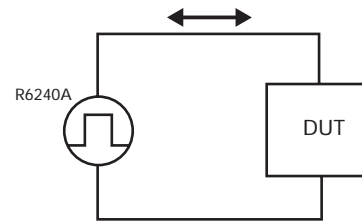

### Can supply to pulse load of maximum 4A (20ms)

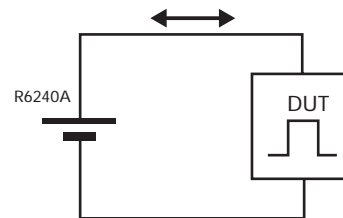

## Suspend Function

The R6240A supports three output OFF states, STBY (output relay OFF), HiZ (output relay ON, high resistance state), and LoZ (output relay ON, low resistance state). This eliminates the ON/OFF operations of the unnecessary relays, thereby solving the existing throughput deterioration problem by relay operation time. In addition, the setting of a suspend voltage (voltage at HiZ or LoZ state) prevents transitional current suction that occurs at connection of a voltage output device such as a battery.

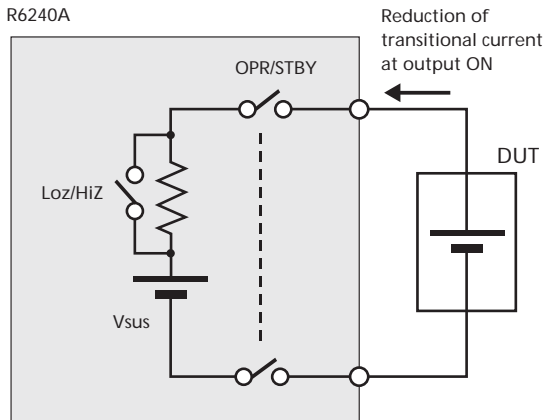

State at output OFF	Output relay	Output state	Current limiter setting value
LoZ	ON	Vsus, low resistance	VS: set current Limiter (IL) IS: 30 digits of the set current range
HiZ	ON	Vsus, high resistance	30μA
STBY	OFF	Open	—

Vsus:Suspend setting voltage (default = 0V)

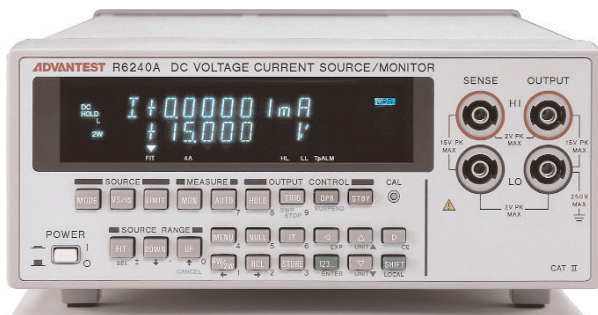

## For measuring ON resistance of MOSFET and analog SW

An example of measuring ON resistance of MOSFET is shown below.

On the drain side, by applying ISVM and 4-wire connection, the R6240A determines the current at the ON state with the source current (IS) and the drain voltage at the OFF state with the voltage limiter.

On the gate side, the SYNC OUT signal is input to TRIGGER IN of the R6240A on the drain side as the pulse source of ISVM. In this way, synchronous measurement by two units is achieved. By using the linear, pulse, or sweep function on the gate side and the fixed sweep function on the drain side, gate voltage – ON resistance characteristics can be measured easily.

- Resistance measuring range: 2.5μ-7.5MΩ
- Maximum current (Id Max): 4A (at pulse width 20ms or less)
- Pulse measurement at the minimum pulse width: 500μs and the minimum cycle: 2ms
- Gate current measurement at resolution 10nA

## Connection diagram

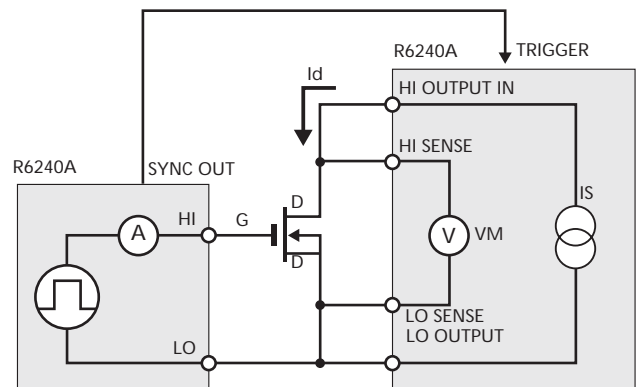

## Measurement waveform diagram

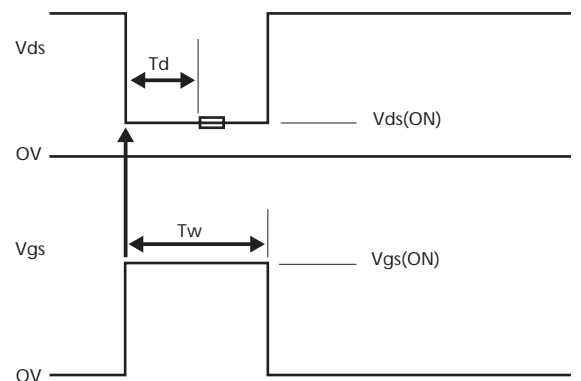

Tds: Drain voltage Vgs: Gate voltage Td: Major delay Tw: Pulse width

## For Battery Charge/Discharge Tests and Power Supply Device Evaluation

The R6240A handles bipolar output and is capable of  $\pm$  source and  $\pm$ sink operations. Therefore, this equipment is capable of 0V sink operation, which is not possible under a general electronic load. With its pulse source function, the R6240A can be used for evaluation of batteries and power supply devices that are used for various portable devices as pulse load.

- Capable of handling pulses of various portable telephones due to its minimum pulse width of 500  $\mu$ s and resolution of 1 $\mu$ s.
- Capable of CV  $\rightarrow$  CC operation for both charging and discharging due to its HI and LO voltage limiters

Both the HI and LO voltage limiters allow the + setting (or - setting). For instance, if HI is set to +1.8V and LO is set to 1.2V, at charging, the constant charge voltage state is reached at +1.8V and at discharging, the constant discharge voltage terminates at +1.2V (constant voltage state).

- Avoids unnecessary discharge at the output ON state by setting a Suspend voltage ( $V_{sus}$ ).

A general power supply is 0V or an open state of 0V when output is OFF and when output is ON, a low impedance state of 0V always occurs.

In this case, the battery discharges instantaneously. However, for instance by setting the Suspend voltage of the R6240A to +1.2V, unnecessary discharge can be avoided since the voltage of the output terminal is the same as that of the battery, which is +1.2V, even in a temporary low impedance state that occurs when the output is ON. This function is useful for preventing FET from being set to ON instantaneously at the output ON state when it is used as a gate voltage of J-FET or GaAsFET.

### Connection diagram

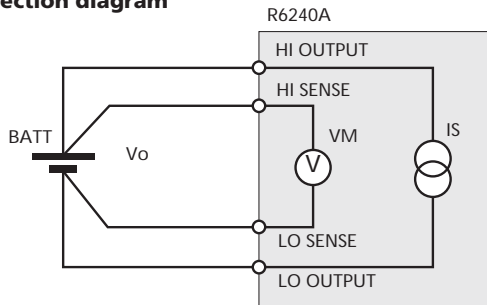

### Pulse discharge waveform

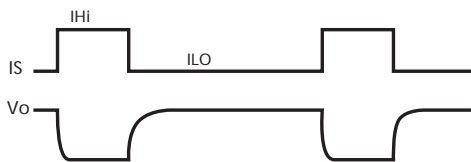

### Battery charge waveform

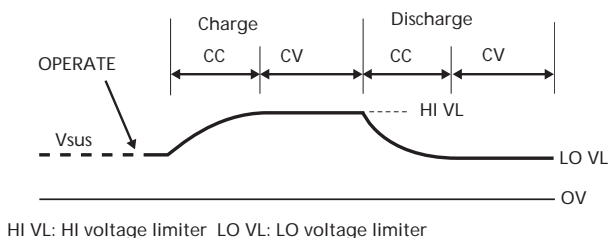

## For Evaluation of Solar Batteries

Since the conversion efficiency of solar batteries is influenced by a bias application time, measurement by pulse application is effective for finding a true conversion efficiency. The R6240A pulse sweep function enables measuring of the characteristics of photoelectric voltage - photoelectric current and photoelectric voltage - photoelectric power at a high speed. By changing the pulse width, characteristic changes that occur according to the application time can be measured easily.

- Minimum pulse width: 500 $\mu$ s, Minimum cycle: Measurement of 2ms pulse
- Maximum current 4A for pulse width 20ms or less
- Minimum voltage step: 100 $\mu$  (3V range)

### Connection diagram

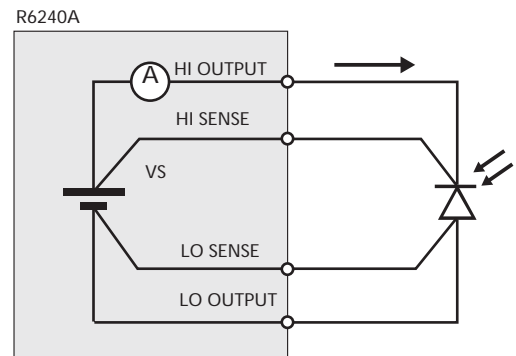

### Measurement waveform

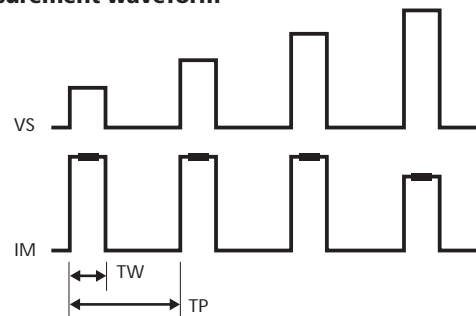

### Characteristics of photoelectric voltage, photoelectric current, and photoelectric power

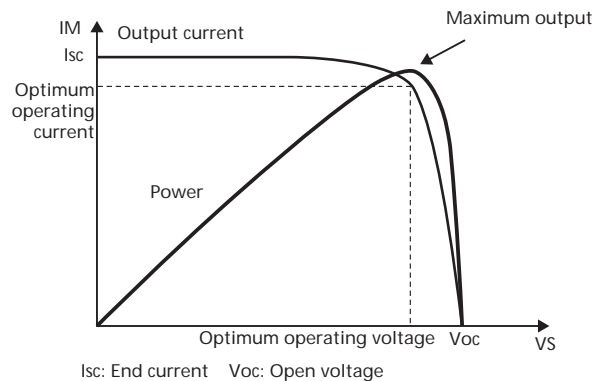

## Specifications

All the accuracies are guaranteed for one year when the equipment is used at temperatures of 23 ± 5°C and relative humidity of 85% or less.

### Voltage source/Measurement range

Range	Source range	Setting resolution	Measurement range	Measurement resolution
3V	0~±3.1000V	100μV	0~±3.19999V	10μV
15V	0~±15.000V	1mV	0~±15.1999V	100μV

### Current source/Measurement range

Range	Source range	Setting resolution	Measurement range	Measurement resolution
3mA	0~±3.1000mA	100nA	0~±3.19999mA	10nA
30mA	0~±31.000mA	1μA	0~±31.9999mA	100nA
300mA	0~±310.00mA	10μA	0~±319.999mA	1μA
1A	0~±1.0000A	100μA	0~±1.01999A	10μA
4A <sup>*)</sup>	0~±4.0000A	200μA	0~±4.01999A	10μA

<sup>\*)</sup>The source range is restricted by the duty factor condition.

For a 4A pulse source, maximum pulse width 20ms/duty factor≤20%

### Resistance Measurement range

Range	Source range	Setting resolution	Measurement range	Measurement resolution
Determined by the operation of Voltage range / Current range	—	—	0~7.5MΩ	Minimum 2μΩ

However, the measurement resolution under integration times 100μs and 500μs will be as follows.

Integration time	100μs	500μs
Measurement resolution (digits)	10	2

### Voltage limiter (compliance) range

Range	Maximum setting	Minimum setting <sup>*)</sup>	Setting resolution
3V	3.100V	60mV	1mV
15V	15.00V	600mV	10mV

### Current limiter (compliance) range

Range	Maximum setting	Minimum setting <sup>*)</sup>	Setting resolution
3mA	3.100mA	60μA	1μA
30mA	31.00mA	600μA	10μA
300mA	310.0mA	6mA	100μA
1A	1.000A	60mA	1mA
4A	4.000A	120mA	1mA

<sup>\*)</sup>Minimum difference between the HI side and LO side in the limiter settings

**Total accuracy:** Including calibration accuracy, 1-day stability, temperature coefficient, and linearity

**1-day stability:** Under constant power supply and load

**Temperature coefficient:** At temperature of 0 to 50°C

### Voltage Source

Range	Total accuracy	1-day stability	Temperature coefficient
	±(% of setting+V)		±(ppm of setting+V)/°C
3V	0.025+350μV	0.01+200μV	15+30μV
15V <sup>*)</sup>	0.025+3mV <sup>*)</sup>	0.01+2mV	15+300μV

### Voltage Limiter

Range	Total accuracy	1-day stability	Temperature coefficient
	±(% of setting+V)		±(ppm of setting+V)/°C
3V	0.05+3mV	0.01+1mV	15+100μV
15V <sup>*)</sup>	0.07+30mV	0.01+10mV	15+1mV

<sup>\*)</sup>For the 15V range, a value of 100μV is added at each remote sense voltage of 0.1V

## Current Source

Range	Total accuracy	1-day stability	Temperature coefficient
	±(% of setting+A+A × Vo/1V)		±(ppm of setting+A+A × Vo/1V)/°C
3mA	0.03+800nA+30nA	0.01+400nA+10nA	20+100nA+1nA
30mA	0.03+8μA+300nA	0.01+4μA+100nA	20+1μA+10nA
300mA	0.045+80μA+3μA	0.01+40μA+1μA	20+20μA+100nA
1A	0.05+800μA+30μA	0.02+400μA+10μA	35+100μA+1μA
4A	0.25+1mA+55μA	0.08+400μA+10μA	35+100μA+2μA

## Current Limiter

Range	Total accuracy	1-day stability	Temperature coefficient
	±(% of setting+A+A × Vo/1V)		±(ppm of setting+A+A × Vo/1V)/°C
3mA	0.045+3.5μA+30nA	0.01+1μA+10nA	20+200nA+1nA
30mA	0.045+35μA+300nA	0.01+10μA+100nA	20+2μA+10nA
300mA	0.055+350μA+3μA	0.01+100μA+1μA	20+10μA+100nA
1A	0.1+3.5mA+30μA	0.02+1mA+10μA	40+200μA+1μA
4A	0.25+6mA+55μA	0.08+1mA+10μA	40+200μA+2μA

Vo: Compliance voltage(-15V to +15V)

## Voltage measurement

(Auto zero: ON, Integration time:1PLC to 200ms)

Range	Total accuracy	1-day stability	Temperature coefficient
	±(% of reading+V)		±(ppm of reading+V)/°C
3V	0.025+120μV	0.008+60μV	15+15μV
15V	0.025+2mV	0.008+250μV	15+50μV

## Current measurement

(Auto zero: ON, Integration time:1PLC to 200ms)

Range	Total accuracy	1-day stability	Temperature coefficient
	±(% of reading+A+A × Vo/1V)		±(ppm of reading+A+A × Vo/1V)/°C
3mA	0.03+700nA+30nA	0.01+350nA+10nA	20+70nA+1nA
30mA	0.03+7μA+300nA	0.01+3.5μA+100nA	20+700nA+10nA
300mA	0.045+70μA+3μA	0.01+35μA+1μA	20+7μA+100nA
1A	0.05+700μA+30μA	0.02+350μA+10μA	35+70μA+1μA
4A	0.25+800μA+55μA	0.08+350μA+10μA	35+70μA+2μA

Vo: Compliance voltage(-15V to +15V)

## Resistance Measurement (Voltage Source)

(Auto zero: ON, Integration time:1PLC to 200ms)

Total accuracy	1-day stability	Temperature coefficient
±(% of reading)±(digits+digits+digits)		±(ppm of reading)±(digits+digits+digits)/°C
reading item: (setting item at voltage source + reading item of current measurement)		
Full scale item: (digit value of the full scale item at voltage source + digit value of the full scale item of current measurement + digit value of the CMV item) <sup>*)</sup>		

## Resistance Measurement (Current Source)

(Auto zero: ON, Integration time:1PLC to 200ms)

Total accuracy	1-day stability	Temperature coefficient
±(% of reading)±(digits+digits+digits)		±(ppm of reading)±(digits+digits+digits)/°C
reading item: (setting item of current source + reading item of voltage measurement)		
Full scale item: (digit value of the full scale item of the current source + digit value of the full scale item of voltage measurement + digit value of the CMV item) <sup>*)</sup>		

<sup>\*)</sup> CMV item = (A × Vo/1V) \* Source or measurement current" × "source or measurement voltage/digit value of 1V

Integration time: For measurement accuracy from 100μs to 10ms and 1-day stability, the following error is added.

Range		Integration time				
		10ms	5ms	1ms	500μs	100μs
Voltage measurement	3V	8	12	20	30	35
	15V	5	10	15	20	25
Current measurement 3mA-1A	4A	12	18	25	30	35
		24	30	45	55	65



**Source linearity:**  $\pm 3$  digits or less  
(However, for the 4A range,  $\pm 0.2\%$  of setting  $\pm 5$  digits or less)

**Maximum output current:**

0 to 15V:  $\pm 1A$ (DC),  
0 to 10V:  $\pm 4A$   
(Maximum pulse width 20ms/duty factor  $\leq 20\%$ )

**Maximum compliance voltage:** 1A (DC): 0 to  $\pm 15V$ , 4A (pulse): 0 to  $\pm 10V$

**Output noise:** No load at voltage source, [Vp-p] within the maximum load  
For the current source, [Ap-p] under the following load resistance

**Voltage Source**

Range	Load resistance	Low frequency noise		High frequency noise
		DC-100Hz	DC-10kHz	DC-20MHz
3V	—	100 $\mu$ V	400 $\mu$ V	5mV
15V	—	1mV	3mV	6mV

**Current Source**

Range	Load resistance	Low frequency noise		High frequency noise
		DC-100Hz	DC-10kHz	DC-20MHz
3mA	1k $\Omega$	200nA	2 $\mu$ A	6 $\mu$ A
30mA	1k $\Omega$	2 $\mu$ A	15 $\mu$ A	20 $\mu$ A
300mA	1k $\Omega$	20 $\mu$ A	100 $\mu$ A	150 $\mu$ A
1A	100 $\Omega$	200 $\mu$ A	1mA	1.5mA
4A	100 $\Omega$	200 $\mu$ A	1mA	1.5mA

**Switching Noise**

		Central value[p-p]	Load resistance
Output ON/OFF noise	Voltage source	600mV	At 100k $\Omega$
	Current source	600mV	At 100k $\Omega$
Range switching noise	Voltage source	50mV	—
	Current source	100 digits+50mV	—
	Voltage limiter	50mV <sup>*)</sup>	—
	Current limiter	50mV <sup>*)</sup>	—
	Voltage measurement	50mV <sup>*)</sup>	—
	Current measurement	50mV <sup>*)</sup>	—
Power OFF noise		600mV	At 100k $\Omega$

<sup>\*)</sup>The limiter is inactive. When the limiter is active, the noise level is the same as that of the source range switching noise.

**Settling time**

Time required to reach the  $\pm 0.03\%$  of the final value when output is changed from zero to the full-scale value (for the 4A range, time required to reach  $\pm 0.1\%$  of the final value). However, this applies under the conditions of net load resistance, load capacity of 200pF or less, and full-scale source and limiter setting values.

	Range	settling time
Voltage source	3V	300 $\mu$ s or less
	15V	700 $\mu$ s or less
Current source	3mA	700 $\mu$ s or less
	30mA	
	300mA	
	1A	2ms or less
	4A	500 $\mu$ s or less

3mA to 1A indicate the settling current range of compliance voltage 15V. 4A indicates the settling current of compliance voltage 10V.

**Overshoot:**  $\pm 0.1\%$  or less (under the net resistance load and at the standard cable end)

**Line regulation:**  $\pm 0.003\%$  of range or less

**Load regulation**

Voltage source :  $\pm 0.003\%$  of range or less (at 4-wire connection under the maximum load)

Current source: According to the CMV item (AXVo/1V) of the total accuracy

**Output resistance:** At 2-wire connection, excluding the output cable

**Maximum load capacity:** Maximum load capacity that does not generate oscillation while the voltage source or voltage limiter is active

Range	Output resistance ( $\Omega$ )		Maximum load capacity
	Voltage source	Current source	
3mA	10m $\Omega$ or lower	100M $\Omega$ or higher	100 $\mu$ F
30mA	10m $\Omega$ or lower	10M $\Omega$ or higher	100 $\mu$ F
300mA	10m $\Omega$ or lower	1M $\Omega$ or higher	2000 $\mu$ F
1A	10m $\Omega$ or lower	100k $\Omega$ or higher	2000 $\mu$ F
4A	10m $\Omega$ or lower	50k $\Omega$ or higher	2000 $\mu$ F

Resistance of the cable attached as the standard:100m $\Omega$  or lower

**Maximum inductive load:** Maximum inductive load that does not generate oscillation while the voltage source or current limiter is active.

Current source range/current limiter range	3mA-4A
Maximum inductive load	1mH

**Effective CMRR:** Under unbalanced impedance 1k $\Omega$

Under DC and AC50/60Hz $\pm 0.08\%$

	Integration time	
	100 $\mu$ s-10ms	1PLC-200ms
Voltage measurement/Current measurement	60dB	120dB

**INMRR:** :Under AC50/60Hz $\pm 0.08\%$

	Integration time	
	100 $\mu$ s-10ms	1PLC-200ms
Voltage measurement/Current measurement	0dB	60dB

**Source and measurement function**

DC source and measurement:	Source and measurement of DC voltage and current
Pulse source and measurement:	Source and measurement of pulse voltage and current (however, not possible for measurement auto range at pulse source)
DC sweep source and measurement:	Source and measurement by linear, random, fixed, and level
Pulse sweep source and measurement:	Source and measurement by linear, random, fixed, and level (however, not possible for measurement auto range at pulse source)
Integration time:	8 types including 100 $\mu$ s/500 $\mu$ s/1ms/5ms/10ms/1PLC/100ms/200ms
Sweep mode:	Reverse ON (two-way)/OFF(one-way)
Sweep repeat count:	1 to 1000, infinite
Maximum number of sweep steps:	5000 steps
Maximum random sweep memory:	5000 data
Measurement data memory:	5000 data
Measurement auto range:	Effective at VSIM and ISVM only
Limiter:	A separate limiter can be set on the HI side and the LO side (however, current limiters of the same polarity are not allowed)
Operation function:	NULL operation, compare operation (HI/GO/LO) Scaling operation MAX, MIN, AVE, and TOTAL operations
Trigger method:	Automatic trigger and external trigger
Output terminal:	Front; safety socket HI OUTPUT, HI SENSE, LO OUTPUT LO SENSE
Maximum input voltage between terminals:	15V peak MAX(HI_LO) 2V peak MAX(OUTPUT_SENSE) 250V MAX(LO_Frame)
Maximum remote sensing voltage:	$\pm 1V$ MAX HI OUTPUT - HI SENSE, LO OUTPUT - LO SENSE, (The voltage between HI SENSE and LO SENSE must be within the maximum output voltage range)

Voltage measurement input resistance:	100MΩ or higher
Voltage measurement input leak current:	±100nA or lower
GP-IB interface:	Complies with IEEE-std.488-1978 Interface function: SH1, AH1, T5, L4, SR1, RL1, PP0, DC1, DT1, C0, E2
Single-wire signal:	<ul style="list-style-type: none"> <li>● TRIGGER IN</li> <li>● INTERLOCK/OPERATE IN/OPERATE OUT</li> <li>● COMPLETE OUT/SYNC OUT</li> </ul>

### Setting time

**Minimum pulse width:** 500μs

**Minimum step (repeat) time:** Under fixed source/measurement range, integration time of 100μs, major delay time of 100μs, operation OFF, and voltage/current measurement

Measurement	Memory mode	Minimum step time
OFF	—	1ms
ON	BURST	2ms
	NORMAL	10ms
	OFF	

### Source delay time

Setting range	Resolution <sup>(*)</sup>	Setting accuracy
0.030ms~60.000ms	1μs	±(0.1%+10μs)
60.01ms~600.00ms	10μs	
600.1ms~6000.0ms	100μs	
6001ms~59998ms	1ms	

### Period (pulse cycle)

Setting range	Resolution	Setting accuracy
1.000ms~60.000ms	1μs	±(0.1%+10μs)
60.01ms~600.00ms	10μs	
600.1ms~6000.0ms	100μs	
6001ms~60000ms	1ms	

### Pulse width

Setting range	Resolution <sup>(*)</sup>	Setting accuracy
0.500ms~60.000ms	1μs	±(0.1%+10μs)
60.01ms~600.00ms	10μs	
600.1ms~6000.0ms	100μs	
6001ms~59998ms	1ms	

### Major delay time

Setting range	Resolution <sup>(*)</sup>	Setting accuracy
0.100ms~60.00ms	1μs	±(0.1%+10μs)
60.01ms~600.00ms	10μs	
600.1ms~6000.0ms	100μs	
6001ms~59998ms	1ms	

<sup>(\*)</sup>The setting resolution is determined by the period time resolution.

### Hold time

Setting range	Resolution	Setting accuracy
1ms~6000ms	1ms	±(2%+3ms)

- Please read the instruction manual before using this product for the correct use.
- A part of the specification may be changed without prior notice due to user requests or enhancement of the quality control of ADVANTEST CORP.

## General Specifications

Operating environment: Ambient temperature; 0°C to 50°C, Relative humidity; 85% or less (no condensation)  
Storage environment: Ambient temperature; -25°C to +70°C, Relative humidity; 85% or less (no condensation)  
Warmup: 60 minutes or more (until the specified accuracy is reached)  
Display: 16 segments x 12 digits fluorescent character display  
Power supply: AC 100V/120V/220V/240V (switchable by the user)

Option No.	Standard	OPT.32	OPT.42	OPT.44
Power source voltage	100V	120V	220V	240V

Line frequency: 50Hz/60Hz  
Power consumption: 95VA or less  
Dimensions: About 212(W) x 88(H) x 400(D)mm  
Mass: 5kg or less

## Main unit

DC voltage and current source/monitor: R6240A

## Standard accessories

Power cable: A01402  
Input/output cable (Red and black safety cable, 1m): A01044  
Alligator clip adaptor: A08532  
Banana chip adaptor: A08531

## Accessories

Text fixture: R12701A  
Test lead (1m): A01041  
Input/output cable (Banana-banana, 4-wire shield, 0.5m): A01047-01  
Input/output cable (Banana-banana, 4-wire shield, 1m): A01047-02  
Input/output cable (Banana-banana, 4-wire shield, 1.5m): A01047-03  
Input/output cable (Banana-banana, 4-wire shield, 2m): A01047-04  
BNC\_BNC cable (1.5m): A01037-1500  
EIA rack mounting set: A02463  
JIS rack mounting set: A02263  
EIA rack mounting set (twin): A02464  
JIS rack mounting set (twin): A02264  
Panel mounting set: A02039  
Panel mounting set (twin): A02040

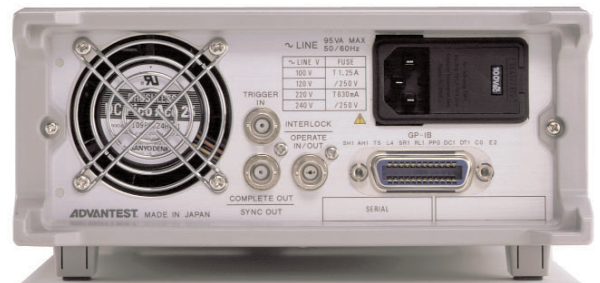

**ADVANTEST CORPORATION**

Shinjuku- NS building, 4- 1  
Nishi- Shinjuku 2-chome  
Shinjuku-ku, Tokyo 163-0880,  
Japan  
Tel: +81-3-3342-7500  
Fax: +81-3-5322-7270  
<http://www.advantest.co.jp>

**Europe:**

**Rohde & Schwarz**  
Europe GmbH  
Mühlendorfstraße 15  
D-81671 München, Germany  
(P.O.B. 80 14 29  
D-81614 München, Germany)  
Tel: +49-89-4129-13711  
Fax: +49-89-4129-13723  
<http://www.rohde-schwarz.com>  
e-mail: [CustomerSupport@rohde-schwarz.com](mailto:CustomerSupport@rohde-schwarz.com)

We support the cutting-edge technology

**ADVANTEST**®

**ADVANTEST CORPORATION**

---