

R&S® Series 5200 RADIOS

ATC radios for voice and data communications



Product Brochure
Version 01.01

AT A GLANCE

The very compact R&S®Series5200 radios combine a secure and flexible architecture with excellent RF performance for today's and tomorrow's full IP communications solutions.

Ready for full IP communications systems

ATC systems are evolving toward flexible and scalable IP architectures based on standardized network elements. The R&S®Series5200 radio interprets this changing scenario and goes beyond the simple concept of ATC radio. The R&S®Series5200 is an advanced and fully integrated network element that also provides a radio connection to the aircraft for voice or data ATC communications.

Like any other IP network element, such as a server or a router, the R&S®Series5200 can easily be integrated into even the most complex network infrastructures, serving as of an "air gateway" connecting the aircraft to the ground communications network.

Voice and data integration

The R&S®Series5200 radios support both amplitude modulation for voice communications as well as ACARS and VDL2 for VHF data links – with the outstanding RF characteristics you expect from a Rohde&Schwarz radio.

Different models supporting VHF or UHF aeronautical bands enable communications with all types of aircraft in the controlled airspace.

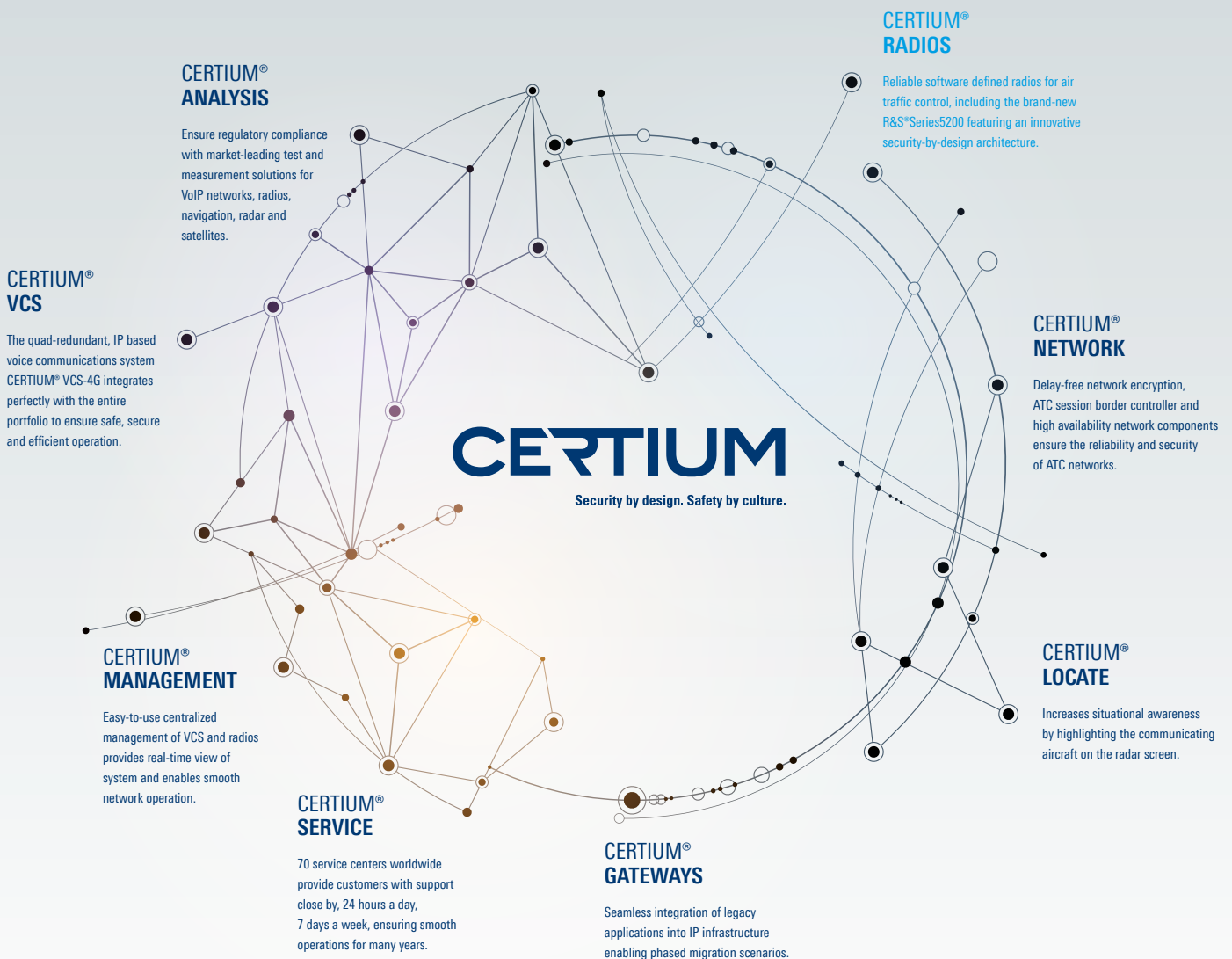

BENEFITS

Secure by design

Development of the R&S®Series5200 focused on cybersecurity as a prerequisite for reliable operation of the air navigation service provider's (ANSP) critical communications infrastructures. This resulted in an intrinsically secure radio architecture, preventing possible cyberattacks and minimizing their impact. User access control management and secure protocols help ANSPs achieve safe and reliable operation of their radio network.

Reduced operational costs

R&S®Series5200 radios require almost no scheduled maintenance. The comprehensive remote control capabilities and extremely simplified radio replacement concept dramatically decrease the need for intervention by highly qualified engineering personnel at the radio stations. This significantly reduces operational costs.

Part of CERTIUM® ecosystem

CERTIUM® is an advanced, ATC communications suite that increases safety and efficiency beyond existing standards.

All CERTIUM® products are harmonized, integrated and extensively tested within the CERTIUM® environment for maximum operational safety and security.

Although each single CERTIUM® product is easy to integrate with third-party systems, you fully benefit from the unique features of the CERTIUM® portfolio when operating CERTIUM® products together.

The R&S®Series5200, part of the CERTIUM® RADIOS, are the perfect match for CERTIUM® VCS and CERTIUM® MANAGEMENT.

Integration flexibility

- ▶ Multiple network interfaces for full integration flexibility
 - ▶ Separation of operational and monitoring networks optimizes IP connectivity
 - ▶ High system availability with redundant network connections
 - ▶ Compatible with any VoIP VCS with support of ED-137A to ED-137C
 - ▶ Smooth migration to VoIP thanks to parallel operation of analog and VoIP interfaces
 - ▶ Support of IPv4 and IPv6
 - ▶ Standardized SNMP interface for remote monitoring and controlling
- ▶ [page 4](#)

Reduced operational and lifetime costs

- ▶ Maintenance free operation with automatic oscillator calibration
 - ▶ Fast and error free radio replacement with R-ID card
 - ▶ Web based interface for intuitive and secure radio configuration
 - ▶ Efficient and safe maintenance operation with maintenance mode
 - ▶ Lower lifetime costs thanks to availability of new functions per software update
 - ▶ Efficient and future-proof installations with very compact form factor
- ▶ [page 6](#)

Superior and reliable radiocommunications for ATC

- ▶ High-quality, reliable communications with excellent RF performance
 - ▶ Integrated voice and data link communications
 - ▶ Scalable automatic radio redundancy
 - ▶ Geographical redundancy with virtual IP address concept
 - ▶ Increased safety with detection of simultaneous transmissions
- ▶ [page 8](#)

Secure by design

- ▶ Software hardening increases resilience of radio operations
 - ▶ True network separation down to the core minimizes impact of cyberattacks
 - ▶ Privileged radio access with user management
 - ▶ Secure connections ensure safe operation
- ▶ [page 10](#)

INTEGRATION FLEXIBILITY

Multiple network interfaces for full integration flexibility

The R&S®Series5200 architecture addresses current and upcoming requirements of ATC communications infrastructures, providing six Ethernet interfaces that ensure full integration flexibility in the most diverse system configurations. One interface is located on the front panel of the radio and is dedicated to local configuration and maintenance operation. Five Ethernet interfaces on the rear panel are available for remote connections.

Separation of operational and monitoring networks optimizes IP connectivity

With a simple configuration, the R&S®Series5200 radio can manage the network traffic of up to three separate networks, e.g. main and backup voice networks and the monitoring network. Each network can be configured separately to match the requirements of different infrastructures, e.g. of different telecommunications providers.

High system availability with redundant network connections

The service availability of the voice infrastructure is of primary importance for air traffic control. This is why ANSP networks are typically deployed with redundant elements (switches, routers) to minimize the probability of an outage. The R&S®Series5200 radios provide support for the connection to redundant networks, allowing direct connection to the redundant infrastructure. This eliminates additional external devices as a single point of failure.

Compatible with any VoIP VCS with support of ED-137A to ED-137C

The R&S®Series5200 supports the latest version of VoIP Standard Eurocae ED-137C that defines the interfaces to VCSs (volume 1), to recorders (volume 4) and to a standardized supervision system (volume 5). The previous versions A and B are also supported, ensuring that R&S®Series5200 is interoperable with any third-party VoIP VCS or recorder.

Operation in a simple system (e.g. small airport)

R&S®GB5450
Compact controller working position



IP network

R&S®Series5200
Transceiver



Parallel operation of VoIP and analog communication

IP VCS

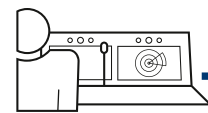

IP network

Legacy VCS

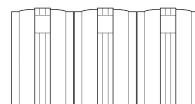

analog

Smooth migration to VoIP thanks to parallel operation of analog and VoIP interfaces

The R&S®Series5200 radios ensure a seamless transition from existing analog voice communications systems to modern VoIP VCSs with parallel operation of analog and VoIP audio interfaces.

Support of IPv4 and IPv6

The R&S®Series5200 radios support both the IPv4 and IPv6 protocol, ensuring full flexibility and scalability of installation in a wide variety of network scenarios ranging from small airport installations to countrywide systems with cross border interconnections.

Standardized SNMP interface for remote monitoring and controlling

Support of the standard SNMP protocol allows easy integration of the R&S®Series5200 radios into a third-party remote control and monitoring system or VCS. Eurocontrol's generic MIB and the comprehensive Rohde&Schwarz MIB both ensure maximal flexibility to match ANSP system requirements.

ection

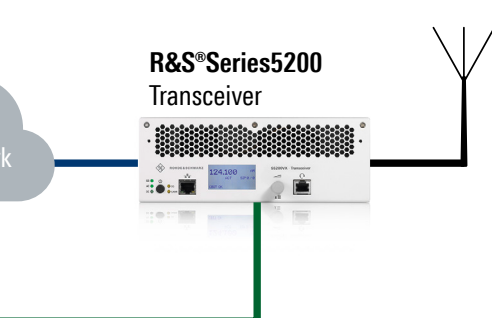

Operation in a complex countrywide system

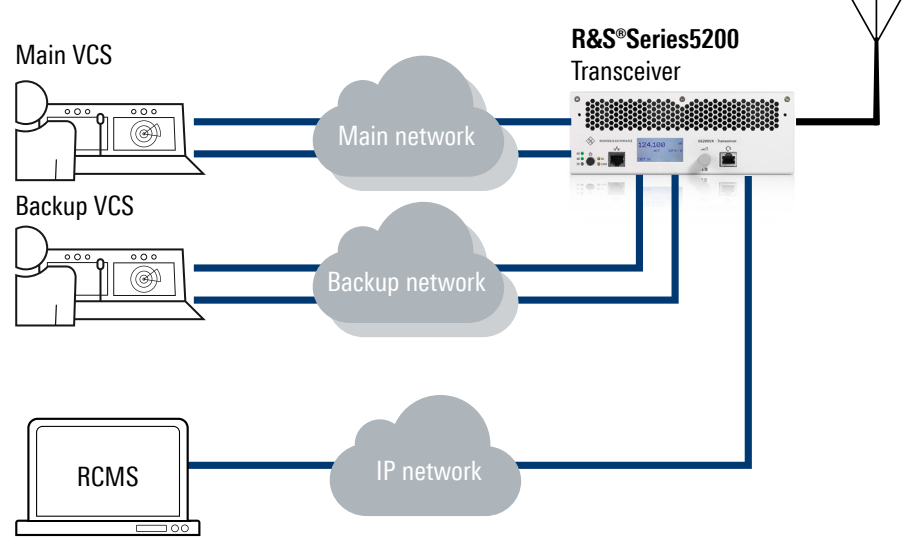

REDUCED OPERATIONAL AND LIFETIME COSTS

Maintenance free operation with automatic oscillator calibration

Although the R&S®Series5200 radios are provided with a high-performance reference oscillator, periodic calibration may still be necessary. If an NTP time server is available in the system, the R&S®Series5200 radio automatically compensates for the aging effects of the oscillator, making the R&S®Series5200 radio a maintenance free device.

Fast and error free radio replacement with R-ID card

In the unlikely event that a R&S®Series5200 radio needs to be replaced at the radio station, it can be very quickly replaced without any radio specific knowledge and without any possibility of mistakes.

The removable radio identity (R-ID) card in the radio hosts the radio's software, configuration and options.

If a radio needs to be replaced, simply extract the R-ID card from the faulty radio and plug it into the spare radio. The correct software, configuration and options are loaded and the spare radio is immediately ready for operation.

Web based interface for intuitive and secure radio configuration

The R&S®Series5200 radios are configured using a secure, modern, user-friendly, browser-based graphical user interface (webGUI).

Access to the webGUI is secured by an https connection. It can be accessed either locally via the maintenance port on the front panel or remotely over the available IP connections. A plug&play mechanism simplifies local access by automatically providing an IP address to the laptop connected to the front panel.

A network administrator manages the access rights to the webGUI by defining authorized users and assigning them different access rights.

For efficient deployment planning of the radio stations, the configuration of the radios can be easily exported, imported and edited offline.

WebGUI in dark mode

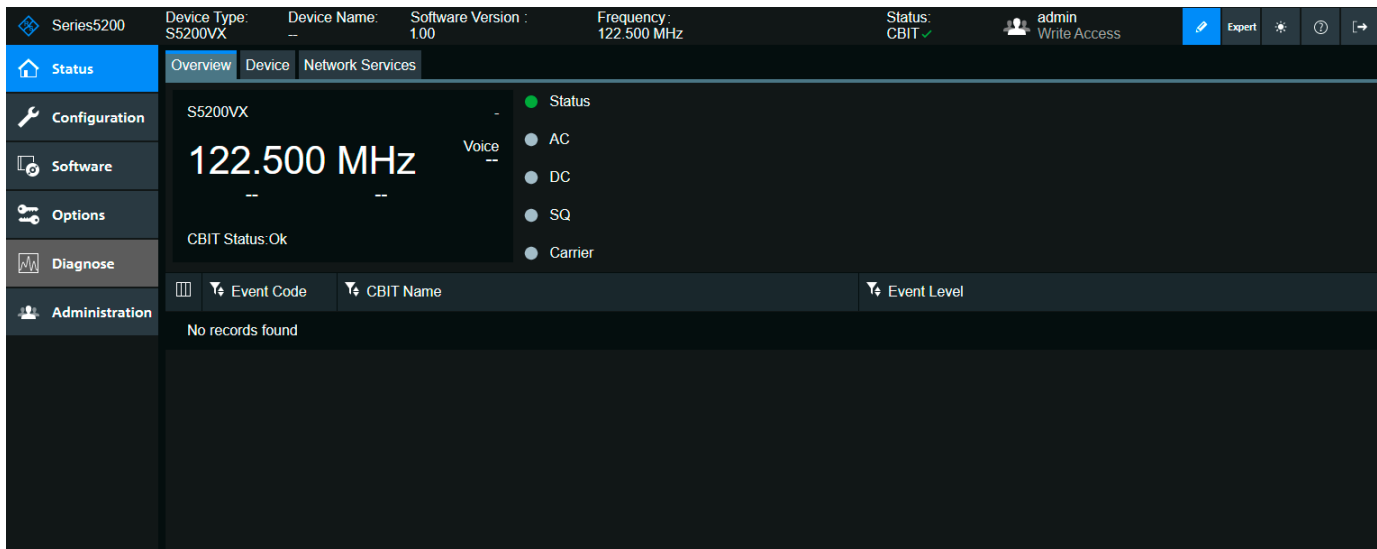

Efficient and safe maintenance operation with maintenance mode

Periodically checking the performance of the operational radio at the radio stations is a time-consuming activity for ANSPs. The ANSP maintenance personnel can benefit from the maintenance mode functionality of the R&S®Series5200. When entering maintenance mode, the radio is automatically reconfigured for performance tests and the central management system is informed of the non-operational status. When leaving maintenance mode, the operational parameter set is automatically recovered, ensuring fast and error free reactivation of the tested radio.

Lower lifetime costs thanks to availability of new functions per software update

The software defined architecture of the R&S®Series5200 radios enables upgrading to new features via simple software updates without any expensive and time-intensive hardware retrofitting. A software upgrade can be performed remotely, eliminating expensive travel to the radio stations. The software transfer process runs in the background while the radio operates and does not affect its functions.

Efficient and future-proof installations with very compact form factor

The R&S®Series5200 radios save 30% space in rack installations compared to the predecessor R&S®Series4200. This significantly reduces the amount of rack space needed for new systems and provides reserve space in existing installations for future channel extensions without additional infrastructure costs.

Two configuration sets in the radio



Normal operation

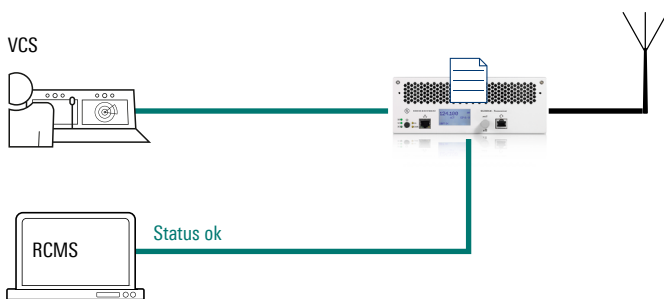

Maintenance operation

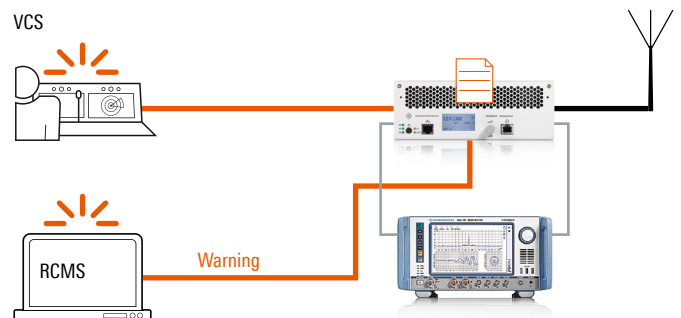

SUPERIOR AND RELIABLE RADIOCOMMUNICATIONS FOR ATC

High-quality, reliable communications with excellent RF performance

Excellence in RF performance is part of the DNA of Rohde&Schwarz. The R&S®Series5200 radio family is designed to operate in the most challenging ATC communications environments, meeting and exceeding the stringent system requirements for civil air traffic control – both for voice communications and data links.

This ensures high-quality, reliable communications even in the presence of strong interference. It also greatly simplifies the system design, minimizing or even eliminating the need for external filters.

Integrated voice and data link communications

The R&S®Series5200 radios are multimode devices that support both voice communications and ACARS/VDL2 data links on the same device.

This significantly simplifies the ANSP 's logistic effort for managing the radio fleet, reducing the need for duplicate spare parts and training for the maintenance team.

Scalable automatic radio redundancy

Critical communications infrastructures require redundancy to achieve the highest availability for practically uninterrupted pilot-controller communications.

The R&S®Series5200 supports the implementation of different automatic radio redundancy mechanisms that are fully independent of the analog or IP VCS in place. For this reason, the R&S®Series5200 represents the perfect solution to increase system availability without additional integration costs.

In the "1+1" automatic main/standby configuration, where every radio is backed up by its own standby device, a pair of R&S®Series5200 radios is treated by the VCS as a single device. This ensures ease of integration and an almost interruption-free communications thanks to a very fast radio switching time.

The "m+n" configuration, where a group of "m" main R&S®Series5200 radios are backed up by a shared pool of "n" standby radios, is also implemented without any external device or VCS support. In case of failure of one of the main devices, one of the available spare radio takes automatically over, without any intervention of the VCS. This ensures an efficient use of the spare radio pool that significantly reduces the investment and lifetime costs. As a standby radio can also take over in case another standby radio fails, this brings higher availability of single frequency compared to "1+1" redundancy.

1+1 main-standby redundancy

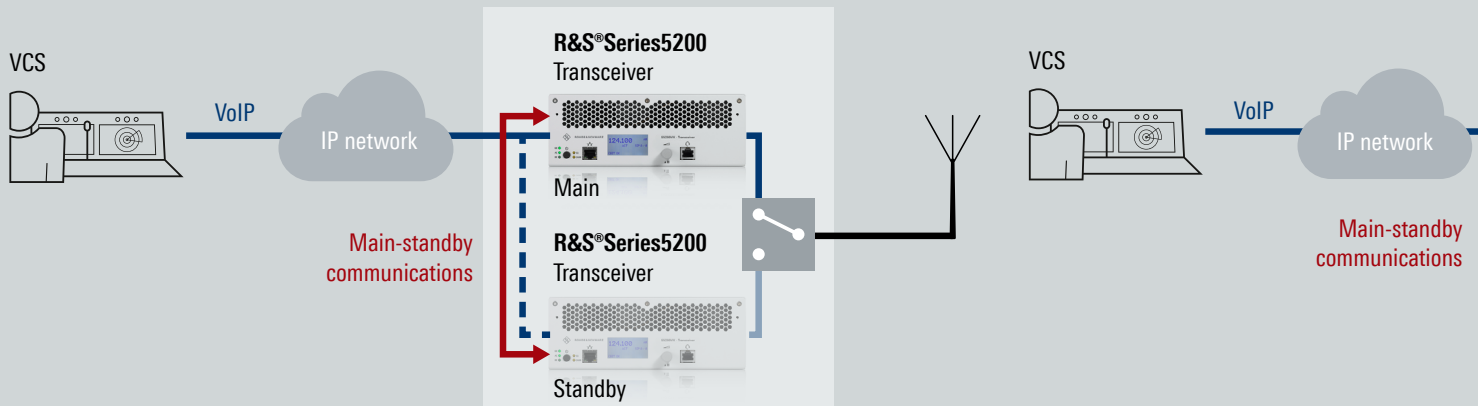

Geographical redundancy with virtual IP address concept

When operating with VoIP VCSs, both the “1+1” and “m+n” redundancy mechanisms of the R&S®Series5200 are combined with the concept of a virtual IP address, which is shared between main and standby radios.

Given proper network connectivity at the radio sites, this mechanism allows to deploy main and backup R&S®Series5200 devices at different radio sites, while the VCS only sees one IP address and the switching is done transparently, i.e. without any action or changes needed at the VCS.

This ensures not only functional, but also geographic redundancy, increasing further the availability of ground communications infrastructures, in case an entire radio site becomes unavailable due to e.g. a fire.

Increased safety with detection of simultaneous transmissions

The R&S®Series5200 radios support the detection of simultaneous transmission (DSiT) feature that increases safety by augmenting the situational awareness of the controllers.

The DSiT feature consists of an algorithm running in the radio receiver, which continuously monitors the spectrum of incoming signals. When the receiver detects the presence of more than one carrier on the radio channel, it raises a warning to inform the controller, who can take action accordingly.

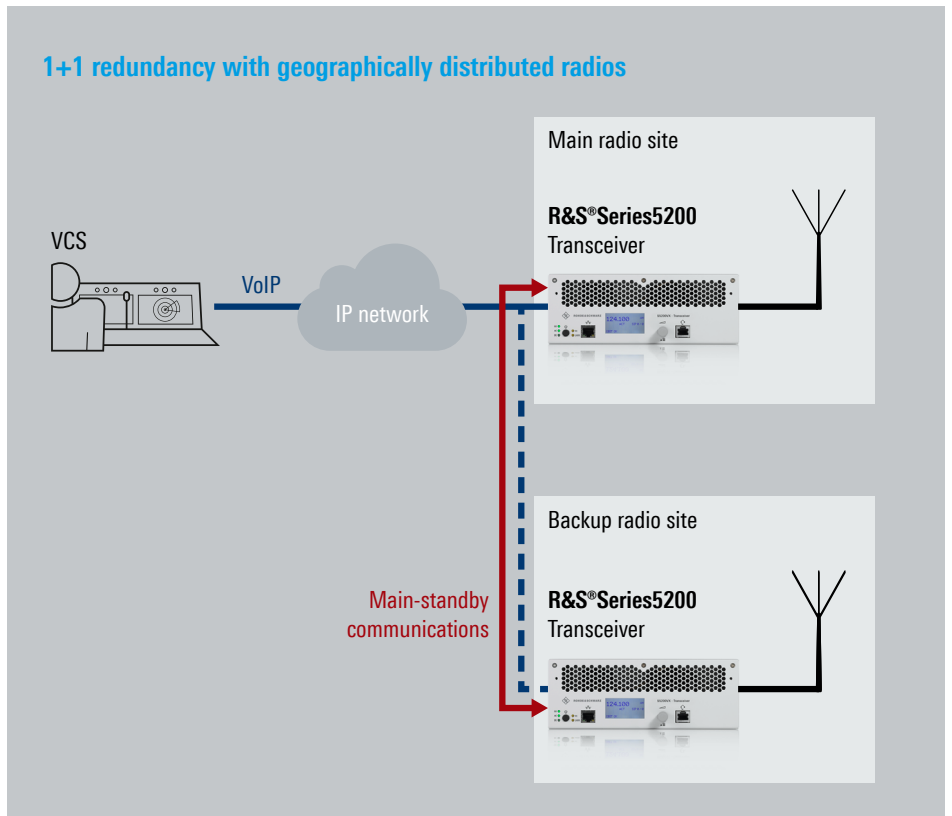
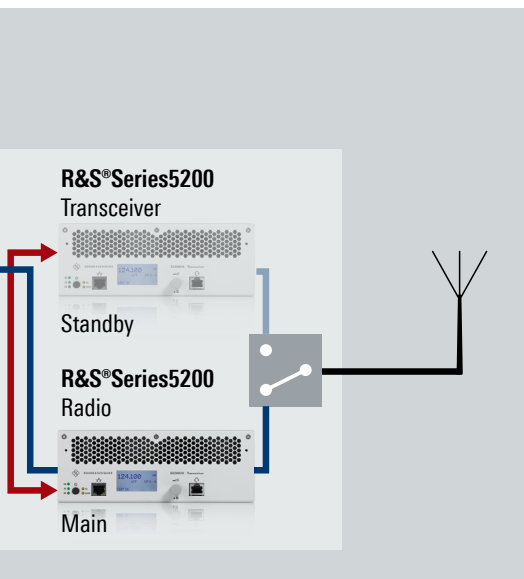

SECURE BY DESIGN

The development of the R&S®Series5200 focused on cybersecurity as a prerequisite for reliable operation of critical ANSP communications infrastructures. The R&S®Series5200 implementation already addresses the relevant recommendations in the Eurocontrol “Voice Over IP Security Handbook”.

Software hardening increases resilience of radio operations

The operating system and the application software for the R&S®Series5200 are designed in line with the most advanced software hardening techniques. The result is an intrinsically secure radio architecture based on a two level approach that prevents possible cyberattacks and minimizes their impact.

True network separation down to the core minimizes impact of cyberattacks

The innovative R&S®Series5200 architecture with its advanced multicore hardware – combined with sophisticated software isolation techniques – provides redundant and fully independent connectivity to main and backup networks. Any security issue appearing on one network will neither impair the operation of the radio nor affect the performance of the other networks, resulting in increased resilience of the entire radiocommunications system.

Privileged radio access with user management

In the R&S®Series5200 radios, a system administrator can define users and assign them different access rights for the configuration and maintenance webGUI. This enables the ANSP to selectively control access to the radio, ensuring that only authorized personnel can access critical information.

Secure connections ensure safe operation

The configuration and management interface and the remote control and monitoring connections transport security relevant information whose misuse can impair the availability of the entire system.

For this reason, the R&S®Series5200 radios support a secure https connection for the webGUI and SNMPv3 for remote control and management, ensuring that the transported information cannot be intercepted and misused.

True network separation down to the core

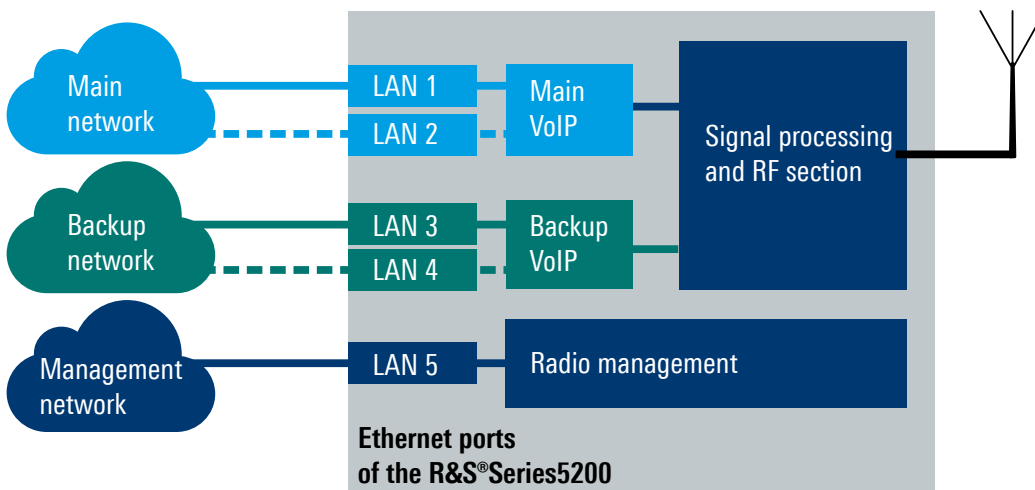

AIRPORT AND REMOTE TOWER APPLICATION

Thanks to its excellent versatility, the R&S®Series5200 is the optimal choice for any airport application.

From a simple airfield where a locally operated stand-alone transceiver is needed to sophisticated remote tower operations with unmanned radio installations requiring IP connectivity for voice and monitoring, the R&S®Series5200 radios are the perfect choice for reliable, high-quality radiocommunications.

The very compact form factor of the R&S®Series5200 satisfies even the most challenging space requirements, which are typical for such applications.



COUNTRYWIDE SYSTEMS AND VIRTUAL CENTER APPLICATION

The flexible architecture of the R&S®Series5200 ideally meets the requirements of the most complex infrastructures of countrywide ATC communications systems.

A secure architecture, multiple network interfaces and automatic radio redundancy are features ANSPs can rely on to efficiently implement a reliable and secure ATC communications system.

Full integration of the R&S®Series5200 with the CERTIUM®VCS-4G is the perfect fit for the challenging IP based virtual center application.

The R&S®RCMS II software suite ensures continuous monitoring of the system, reporting to the supervision operator in real time the status of all radios distributed across the country.

All components necessary for a complete radio site, such as racks, multicouplers, filters and antennas, are also part of the CERTIUM® advanced communication suite.

EASY AND INTUITIVE USER INTERFACE

TRANSCIVER/TRANSMITTER

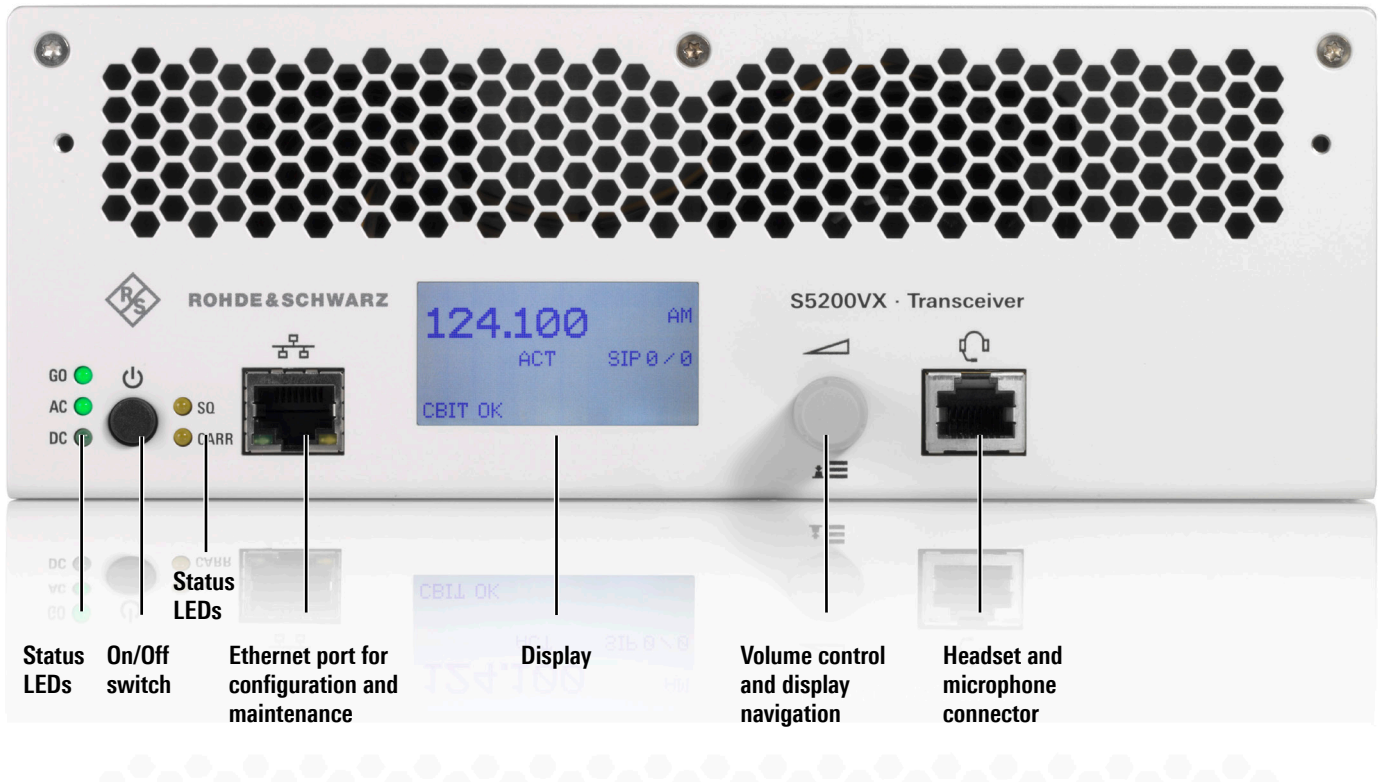

RECEIVER

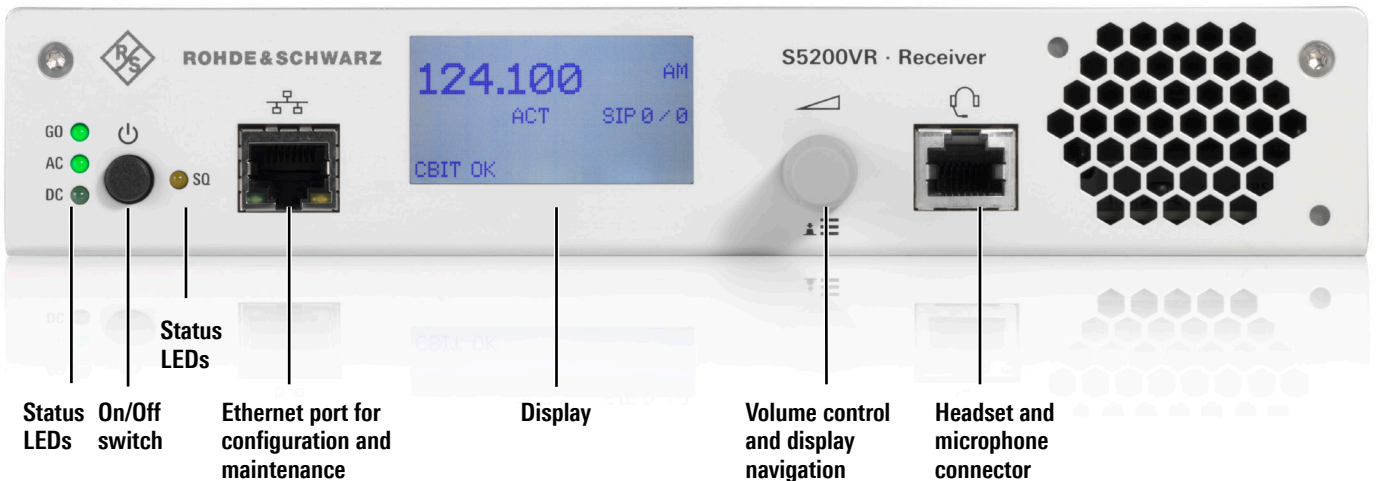

MULTIPLE INTERFACES FOR FLEXIBLE DEPLOYMENT

TRANSCIVER/ TRANSMITTER

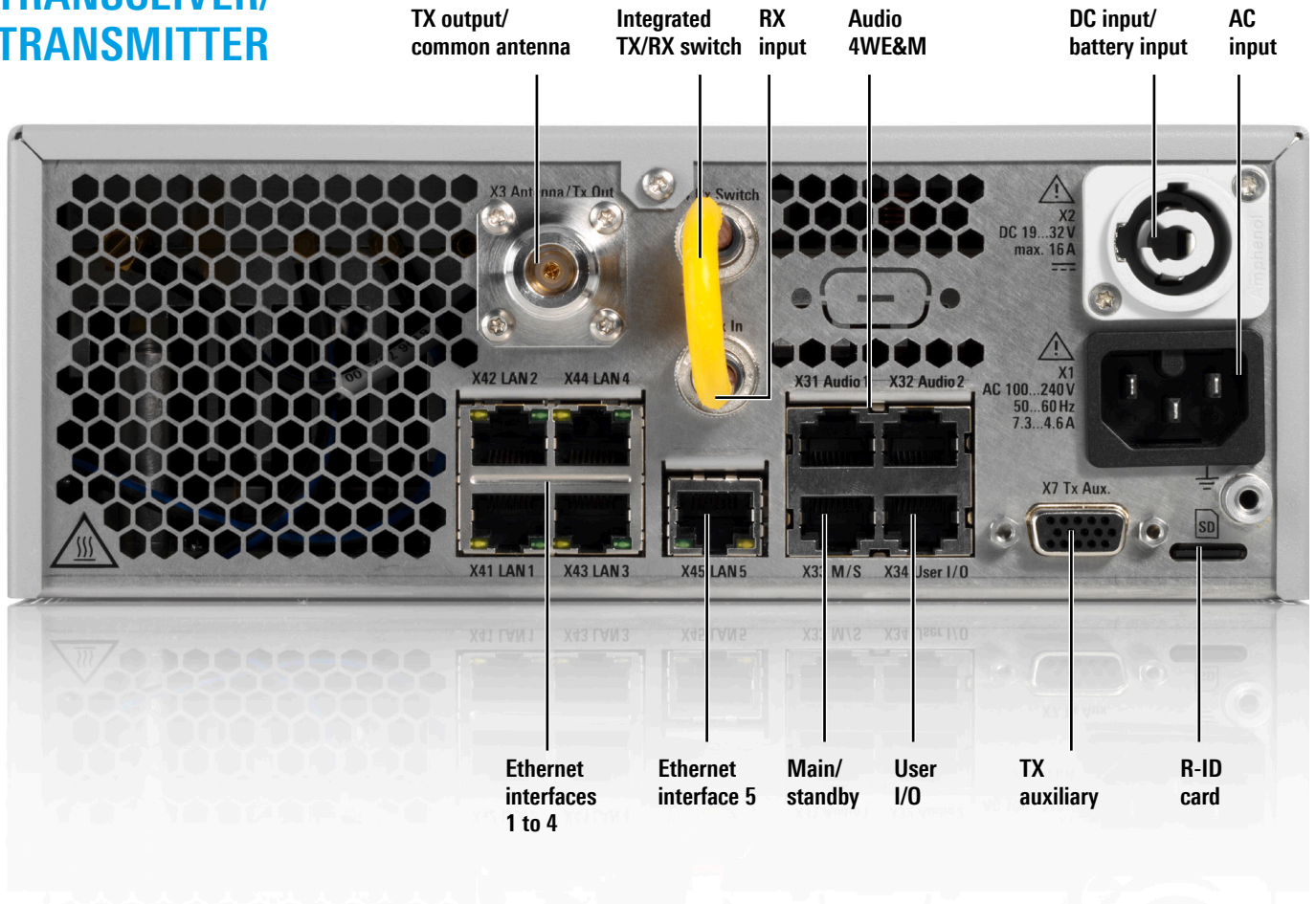

RECEIVER

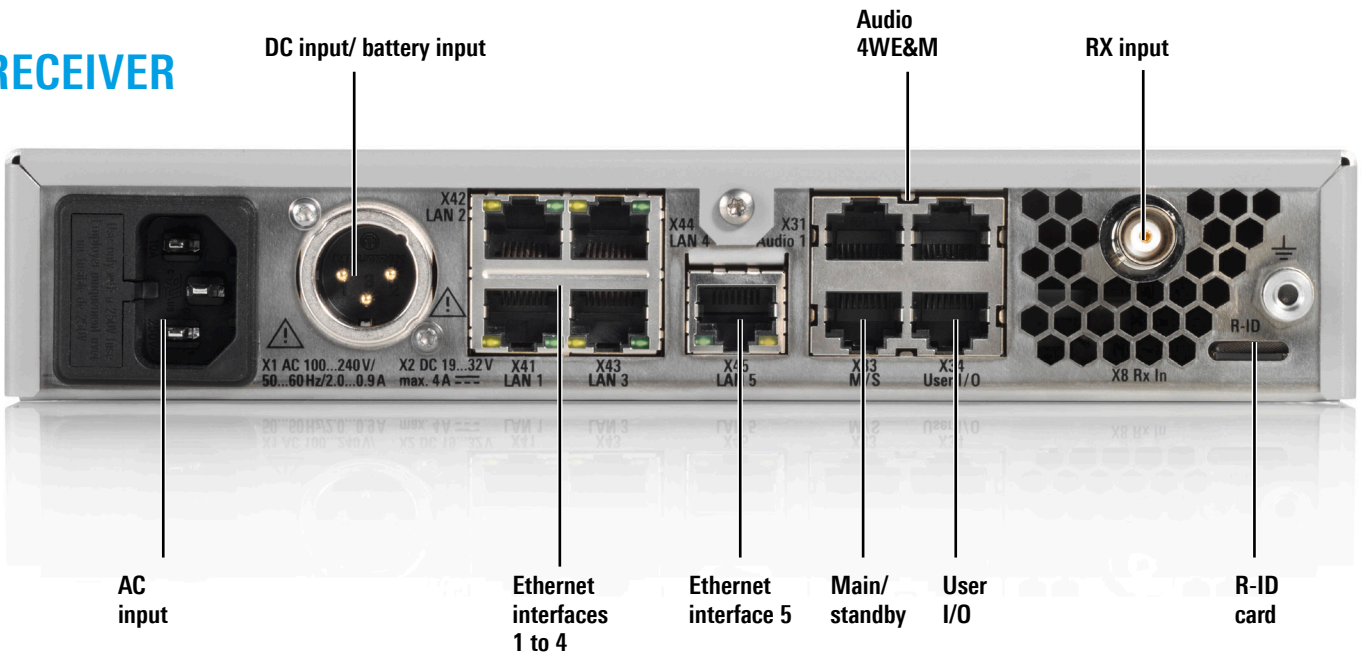

Service that adds value

- ▶ Worldwide
- ▶ Local and personalized
- ▶ Customized and flexible
- ▶ Uncompromising quality
- ▶ Long-term dependability

Rohde & Schwarz

The Rohde & Schwarz electronics group offers innovative solutions in the following business fields: test and measurement, broadcast and media, secure communications, cybersecurity, monitoring and network testing. Founded more than 80 years ago, the independent company which is headquartered in Munich, Germany, has an extensive sales and service network with locations in more than 70 countries.

www.rohde-schwarz.com

Sustainable product design

- ▶ Environmental compatibility and eco-footprint
- ▶ Energy efficiency and low emissions
- ▶ Longevity and optimized total cost of ownership

Certified Quality Management
ISO 9001

Certified Environmental Management
ISO 14001

Rohde & Schwarz training

www.training.rohde-schwarz.com

Rohde & Schwarz customer support

www.rohde-schwarz.com/support

