

# R&S® Installation Manager

# Getting Started

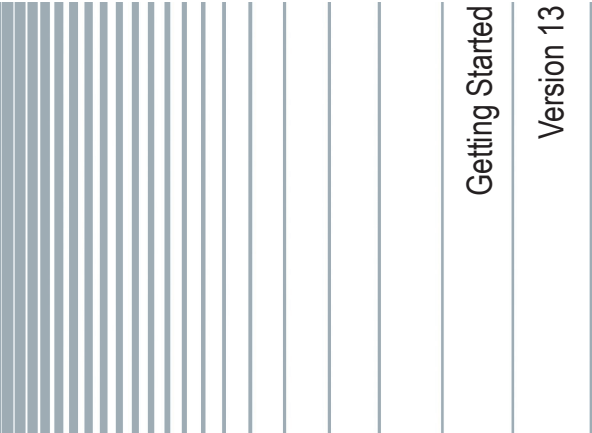

This manual applies to version **1.21** and later of the R&S®CMW-KT007, installation manager (1208.8744.02).

The software is free of charge and does not require a license.

The software contained in this product makes use of several valuable open source software packages. For information, see the "Open Source Acknowledgment" documents on the Rohde & Schwarz website at <https://www.rohde-schwarz.com/firmware/cmw500-pt/>.

Rohde & Schwarz would like to thank the open source community for their valuable contribution to embedded computing.

© 2020 Rohde & Schwarz GmbH & Co. KG

Mühlendorfstr. 15, 81671 München, Germany

Phone: +49 89 41 29 - 0

Email: [info@rohde-schwarz.com](mailto:info@rohde-schwarz.com)

Internet: [www.rohde-schwarz.com](http://www.rohde-schwarz.com)

Subject to change – Data without tolerance limits is not binding.

R&S® is a registered trademark of Rohde & Schwarz GmbH & Co. KG.

Trade names are trademarks of the owners.

1208.8750.02 | Version 13 | R&S®Installation Manager

The following abbreviations are used throughout this manual: R&S® is abbreviated as R&S. R&S®Installation Manager is abbreviated as Installation Manager. Microsoft®Windows® is abbreviated as Microsoft Windows or Windows.

# Contents

<b>1 Preface.....</b>	<b>5</b>
<b>1.1 Documentation Overview.....</b>	<b>5</b>
<b>1.2 Conventions.....</b>	<b>6</b>
<b>2 Introduction.....</b>	<b>7</b>
<b>3 Concepts.....</b>	<b>11</b>
<b>3.1 Software Repositories.....</b>	<b>11</b>
<b>3.2 Installation Manager Database.....</b>	<b>14</b>
<b>3.3 Automatic Updates of Database and Installation Manager.....</b>	<b>16</b>
<b>3.4 Licensing Information.....</b>	<b>17</b>
<b>3.5 R&amp;S Installation Manager Service.....</b>	<b>18</b>
<b>3.6 Download Resources.....</b>	<b>18</b>
<b>4 Installing and Starting the Application.....</b>	<b>20</b>
<b>5 Creating Repositories.....</b>	<b>22</b>
<b>6 Activating Repositories.....</b>	<b>24</b>
<b>7 Selecting Products and Actions.....</b>	<b>26</b>
<b>8 Executing Scheduled Actions.....</b>	<b>28</b>
<b>9 Contacting Customer Support.....</b>	<b>31</b>
<b>Glossary: Abbreviations and Terms.....</b>	<b>32</b>
<b>Index.....</b>	<b>35</b>



# 1 Preface

This guide is a compact introduction to installing and uninstalling software using the Installation Manager. It focuses on typical tasks and provides step-by-step procedures for using most important features.





## 1.1 Documentation Overview

This section provides an overview of the R&S CMW-KT007 user documentation.

The "Installation Manager" documentation is part of the R&S CMW protocol testing user documentation.

After registration on [GLORIS](#), you can select from these options for viewing and downloading documentation:

- **In the Installation Manager**

In the "Products" and "Details" views, use the buttons in the "Info" column for viewing manuals , release notes , features & functions  or open source acknowledgements .

If you have enabled "Settings" > "Show advanced settings" > "Repository Synchronization", the Installation Manager downloads all documents that are linked to a product or software to the specified software repository.

- **On GLORIS**

Visit GLORIS at <https://gloris.rohde-schwarz.com>.

Point to "Support&Services", and then select "My Products" > "MRT Customer Web". Use the product categories and then the documentation types for narrowing down the number of hits.

### Getting started guide

Introduces the Installation Manager and describes how to set up and start working with the product. A printed version is delivered with the instrument.

### "Installation Manager" help

Offers quick access to the complete information about using the Installation Manager.

## Features & functions

Summarizes the features. The "Installation Manager" features & functions is available on [GLORIS](#) (registration required).

## Release note

Provides additional information about software changes. The "Help" view provides a link to the latest release note on GLORIS.

## 1.2 Conventions

This document uses the following typographic conventions to make information easier to access and understand.

**Table 1-1: Typographic conventions**

Convention	Description
"Reference" "GUI element" "Menu name > command"	"Quotation-marks" enclose references or graphical user interface citations to other documentation parts. The > symbol indicates a path or an order to follow for making selections on the GUI. Example: On the taskbar, click "Start > All Programs > ...".
[Key]	Square brackets around a word indicate a key name. Example: [Ctrl] key.
<i>Input</i>	Letters in <i>italic</i> indicate a value that you must type in as shown. Example: <i>5400</i> .
code	Letters in fixed-width font indicate file names, commands, or program code.
<a href="#">Link</a>	Letters in blue font indicate links that you can follow.
<b>emphasis</b>	Letters in boldface indicate <b>emphasized</b> words.
<variable>	Angle brackets enclose variable values. Example: <release>.

## Screen captures

Screen captures generally serve as examples and for illustration. Actual screens and required settings can differ from the examples.

## 2 Introduction

The Installation Manager is an application that lets you install the software that is necessary for testing of wireless devices in a consistent way. You can administer the complete installation of many Rohde & Schwarz products and supporting software on different platforms.

### Welcome view

The Installation Manager user interface runs in a web browser window. The following figure shows the "Welcome" view that opens after starting the application.

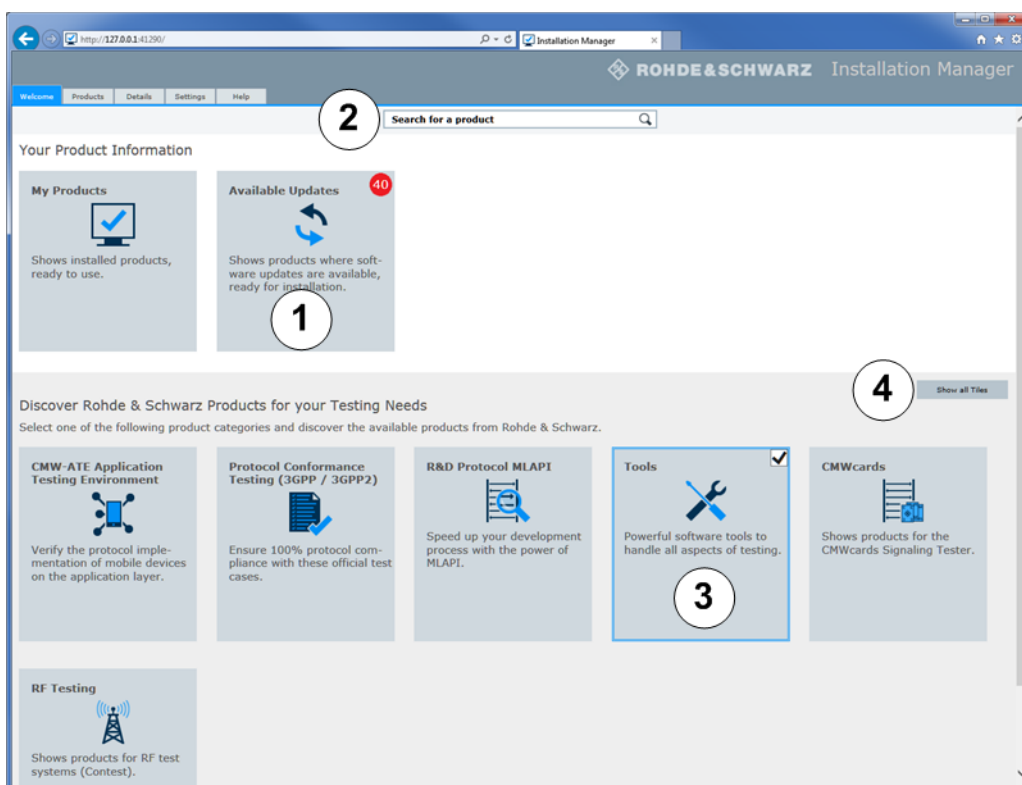

**Figure 2-1: Welcome view**

- 1 = "Available Updates" tile indicating the number of software products that are ready for update
- 2 = Search box for searching by product name
- 3 = Tiles with predefined filter categories; here: "Tools" category
- 4 = Toggle button "Show all Tiles"/"Apply"

The "Available Updates" tile indicates the number of products ready for installation at a glance (1).

With a single click on a product category tile, you can locate the products you are interested in (3). Alternatively, start typing the product's name in the search box (2) and select the product from the hit list.

All results are shown in the "Products" view.

## Products view

After switching to the "Products" view, you can perform typical installation tasks, see the following figure.

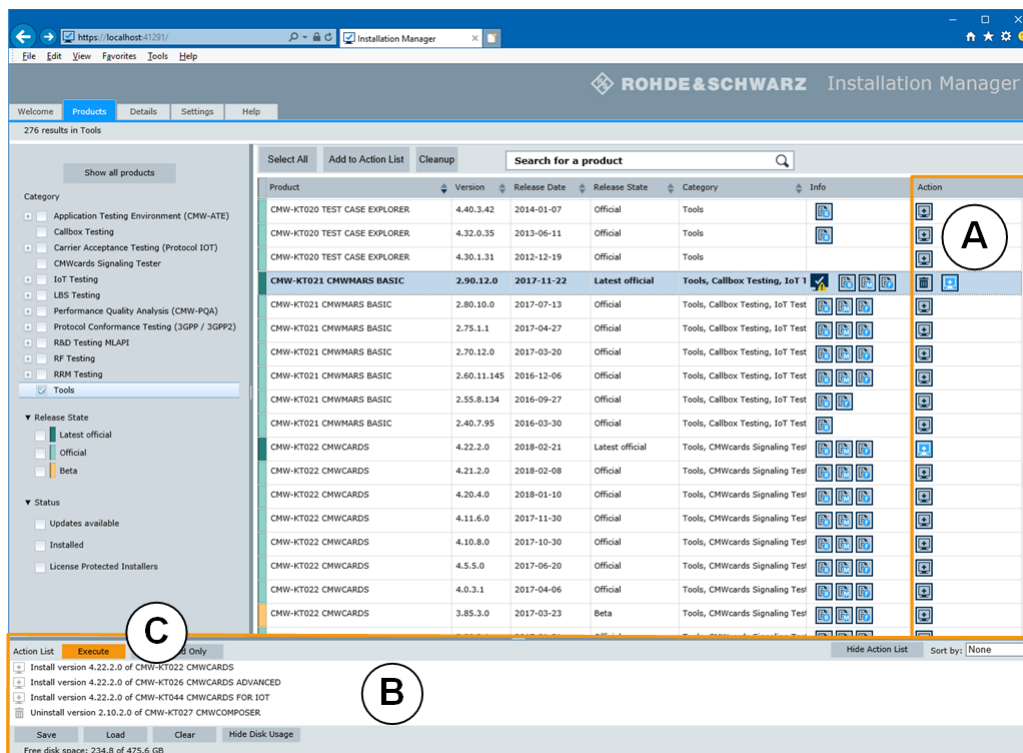

**Figure 2-2: Products view**

A = Selected actions, for example, "Install version"

B = "Action List"

C = "Execute" scheduled actions

You first collect all actions in a shopping cart like "Action List" (B). If you are finished, you execute (C) the "Action List" and thus actually install the products.

## Key features

Generally, due to continuous updates, several valid versions of a product are available in a repository. Things get complicated because of relations and dependencies between the products. If a product is based on other ones, a specific product version only works with certain versions of other products.



The Installation Manager frees you from taking care of such relations. It checks the dependencies between products and installs the product you selected and also all other needed products with the appropriate versions. This procedure can include uninstalling of already installed components with non-matching version numbers and replacing them by the appropriate versions.

- Web-based user interface: The Installation Manager user interface runs in a web browser.
- Comprehensive range of installations: You can install CMW BASE software, firmware applications, tools, test cases, test scenarios, environmental and other supporting software.
- Consistent installation: Dependencies of a selected product to other products are resolved by considering appropriate version numbers.
- Convenient search facilities: You can search for a product by entering a name or selecting categories in a faceted search.
- Bulk processing: Selected products are collected in a list; eventually all entries on the list are downloaded and installed with one action.

The following figure illustrates the three-step update procedure for products that are already available in a "software repository". A software repository is a location in the file system where all software installers and the Installation Manager data-base reside.



**Figure 2-3: Three-step software update procedure**

### Target platforms

The Installation Manager installs products on the platform where it is running.

**Supported platforms**

- R&S CMW500 Protocol Tester/CMWcards Signaling Tester
- R&S CMW290 IoT tester
- R&S CMWC Multi-CMW Controller
- R&S CMW-CU Control Unit running Windows 7
- R&S CONTEST system controller PC running Windows 7 or later
- Standard PC running Microsoft Windows 7 or later

For more information about the features, see the "Installation Manager" features & functions document.

## 3 Concepts

The Installation Manager uses **software repositories** as sources for installations. In combination with the **Installation Manager database**, it only takes the products and product versions from the applied software repositories into account.

The following figure shows involved components and how the Installation Manager is used.

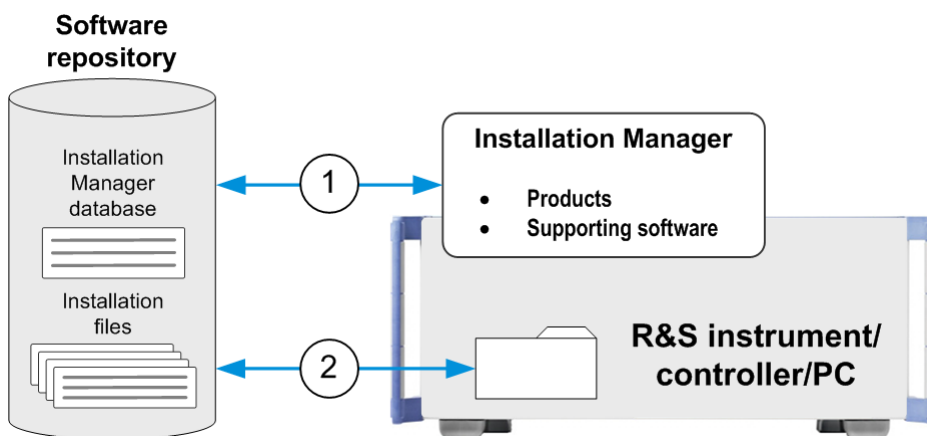

**Figure 3-1: Basic functionality of the Installation Manager**

1 = Scan software repository: Read-in Installation Manager database, and detect available installation files

2 = Install products and supporting software on the platform

• <a href="#">Software Repositories</a> .....	11
• <a href="#">Installation Manager Database</a> .....	14
• <a href="#">Automatic Updates of Database and Installation Manager</a> .....	16
• <a href="#">Licensing Information</a> .....	17
• <a href="#">R&amp;S Installation Manager Service</a> .....	18
• <a href="#">Download Resources</a> .....	18

### 3.1 Software Repositories

Software repositories are typically made up of folders that contain software installers. They can be on any accessible data storage. For example, software repositories can be on the hard disk drive of your Rohde & Schwarz test instrument, on your company network or on removable media (USB stick, DVD).

The Installation Manager is able to work with up to three independent software repositories concurrently. Each software repository can be structured in subfolders or provide shortcuts to folders outside the current system, for example, onto network drives. If several and structured software repositories are used, the Installation Manager displays the installable products contained in these repositories in a flat list as if there is just one flat repository.

The Installation Manager recognizes Windows installer and executable files (\*.msi or \*.exe) for installation. In addition, one of the software repositories must contain the Installation Manager database (InstallationManager\_<number>.rsupd), see [Chapter 3.2, "Installation Manager Database"](#), on page 14.

### Filling or updating software repositories

Rohde & Schwarz provides current versions of the installable products on the Internet, typically on [GLORIS](#) and a **download server** (registration required). You can download the current products from the Internet to fill your own software repositories. The following figure summarizes the options for updating Rohde & Schwarz software and for using several software (SW) repositories.

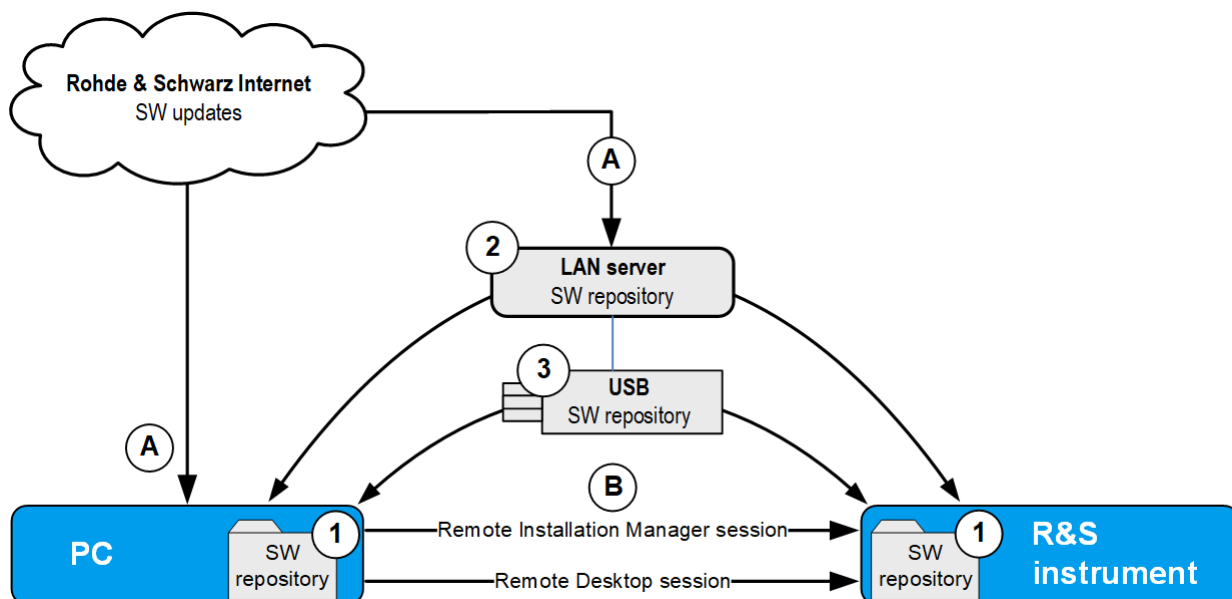

**Figure 3-2: Software update and software repositories (example)**

- A = Software download and update options from GLORIS or download server
- 1, 2, 3 = Selectable software repositories (examples): 1: local folder, 2: shared folder on the company LAN, 3: USB media (exchangeable repository)
- B = Remote access options: Run Installation Manager remotely or open a "Remote Desktop Connection" to maintain software installations on instruments

Rohde & Schwarz recommends updating the software repository regularly to take advantage of latest product versions and software updates.

Use one of the following options:

- Synchronize your software repository with the Rohde & Schwarz download server (recommended).
- Download the software from GLORIS. You can put missing products or software in an action list for instant download and installation. Alternatively, you can save the download actions to file and run them later.

### Synchronizing software repositories

Rohde & Schwarz maintains a **download server** containing the current versions of all officially released software and the latest Installation Manager database. Furthermore, it contains the versions from previous software releases. The download server is updated regularly.

You can manually download software from the download server or automatically synchronize (mirror) the folder on the download server with the **software repository** in your company, see the following figure.

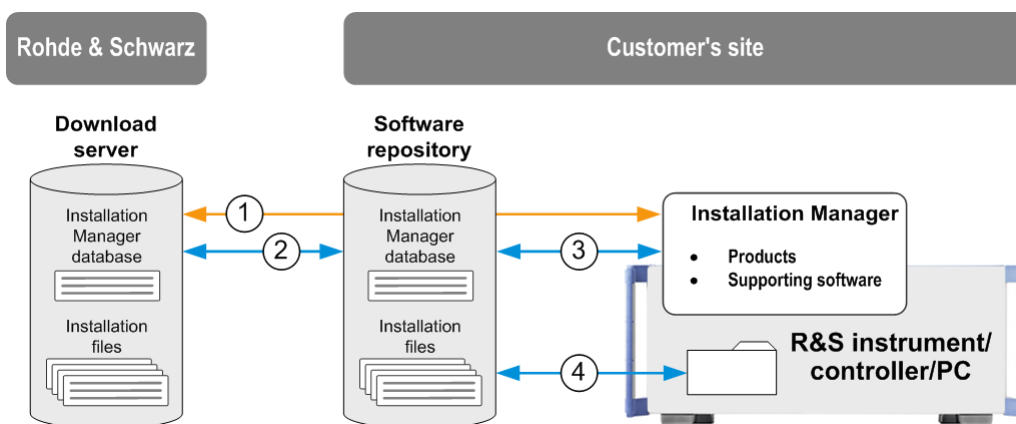

**Figure 3-3: Synchronizing software repository at customer's site**

1 = Read-in Installation Manager database directly from the download server

2 = Synchronize/mirror software repository

3 = Scan software repository, read-in Installation Manager database and detect available installation files

4 = Install products and supporting software on the instrument or PC

For more information about the Rohde & Schwarz download server address and port settings, see [Table 3-1](#).

You can select from the following options for automatic synchronization ((2) in the previous figure):

- Configure the Installation Manager for repository synchronization (recommended).  
For more information about this feature, see the "Installation Manager" help.
- Realize repository synchronization using a 3rd party tool, for example, WinSCP. WinSCP is an open source free SFTP client for Windows. It lets you download files or mirror directories and files from SFTP secured download servers in an automated way.

For information about performing manual or automatic synchronization, see the "R&S CMW500 Protocol Testing - Test Setups and Use Cases" manual.

## 3.2 Installation Manager Database

The Installation Manager obtains its information from the **Installation Manager database**. This database contains information about the products that are provided by Rohde & Schwarz to be installed with the Installation Manager and the Installation Manager itself. The database also includes conditions for installations, especially dependencies between software packages and version numbers.

The Installation Manager database is realized as a `InstallationManager_<number>.rsupd` file. You can download the latest Installation Manager database version from the Internet. Store the database in a software repository which the Installation Manager is connected with.



The Installation Manager always works on a copy of the latest Installation Manager database that was found in the software repositories. The file is stored here:

```
%ProgramData%\Rohde-Schwarz\InstallationManager\  
InstallationManager_<number>.rsupd
```

---

The Installation Manager exploits the information of the database in many ways including the following.

### Software scan

When the Installation Manager starts, it compares the software already installed or available in the connected software repositories with the database entries. It

detects if the installed software is up-to-date according to the version numbers in the database or if the software repositories contain the latest software versions.

When you click "Apply and Rescan" in the "Settings" view, the Installation Manager scans the activated software repositories and evaluates dependencies. In this way, it detects all changes since the last scan.

The Installation Manager informs you about recommended updates. You can either install selected products or cancel without installation.

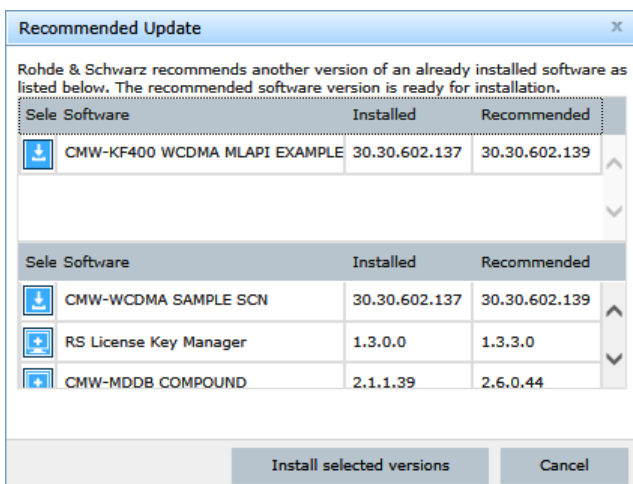

Figure 3-4: Recommended Update dialog box



The recommended update notification is also possible due to missing prerequisites. Verify the "Details" view > "Action List" on added software and scheduled actions.

## Evaluation of dependencies

A product or software can rely on other products or software for proper functioning; a specific version of software can only work with specific versions of other components. When you select a product or software, the Installation Manager calculates a dependency tree for this software and derives the required installation actions.

For example, the selected software **A** requires another software **B** with a certain version number whereas an older version of software **B** has already been installed.

## Automatic Updates of Database and Installation Manager

In this case, the installation actions include the following:

1. Uninstallation of software **B** with old version
2. Reinstallation of software **B** with the new version
3. Installation of software **A**

You can inspect the dependencies for selected software in the "Details" view. In the "Products" view, the dependencies are not shown but are evaluated in the background.

### Relations between software and hardware

The Installation Manager database contains information about which products can be installed on which test instruments. The Installation Manager detects the type of test instruments on which it is running. Only those products are displayed which can be installed on that instrument according to the database.

Optionally, you can command the Installation Manager on a PC to simulate that it is running on a specified test instrument ("Simulation Mode").

### Available updates of the Installation Manager

The Installation Manager database contains its version number and information about the latest known Installation Manager version. This information is a prerequisite for automatic updates as described in the next section.

## 3.3 Automatic Updates of Database and Installation Manager

The Installation Manager automatically updates its database and offers an instant update to a new Installation Manager version.

### Database update

The latest version of the Installation Manager database is provided on the Internet for download. The database is frequently updated, for example if new products or new software versions are available. The Installation Manager periodically looks for a new version on the Internet. If a newer version than the current one in the software repository is detected, the new version is automatically downloaded and replaces the old version in the software repository.



## Installation Manager update

An installer file for the latest version of the Installation Manager is provided on the Internet for download. The Installation Manager detects from the current database if a newer Installation Manager version than the currently installed one is available. In this case, it offers an update installation to the latest version with the "Update Available" dialog.

You are guided through the installation process that includes a download if the latest version is only available on the Internet and not in an activated software repository.

The new Installation Manager version maintains the settings from the previous version, for example, the software repositories.

## Proxy authentication

In general, no login is required for downloading the database or the Installation Manager installer file from the Rohde & Schwarz download area on the Internet.

Depending on the network settings of your company, proxy credentials are required to access the Internet:

- Name of the proxy server (system settings are used by default)
- Proxy user name
- Proxy password

Specify your credentials in the Installation Manager > "Settings" view > "Show advanced settings > Automatic Update".

## 3.4 Licensing Information

Typically, software products from Rohde & Schwarz are subject to license conditions. If you purchase a licensed software product, Rohde & Schwarz sends you one or more license keys or license files that contain the license keys (in short: licenses). To activate the licenses, you need a smart card reader and a smart card (full size or SIM size). For running software products, all necessary licenses must be active and permanently available.

The Installation Manager evaluates the licensing information provided by the License Proxy and the License Server. The Installation Manager indicates licensing issues already before starting any download or installation task.



### Failed license request

The key symbol in the "Info" column indicates a licensing issue, see the "Installation Manager" help, "Quick Reference". As a consequence, downloading and installing the software is not possible.

On Rohde & Schwarz instruments, the "Device Footprint" view provides information about active licenses, see the "Installation Manager" help, "Advanced Tasks".

When an R&S CONTEST smart card is detected, the platform is set to "System Controller".



### Licensing prerequisites on PCs

The Installation Manager can evaluate the licensing information on a PC when at minimum one product is installed. Initial product installation comprises License Server and License Proxy as a prerequisite.

For details about installing and activating licenses, see the "License Server" and "License Proxy" documentation.

## 3.5 R&S Installation Manager Service

A service named "InstallationManager" (display name "R&S Installation Manager") manages installation requests from Rohde & Schwarz applications. For successfully running the Installation Manager, this service must be started and running.

On multi-CMW (LAN) setups, the service must run on the R&S CMW-CU and all connected R&S CMW instruments.

## 3.6 Download Resources

The Installation Manager lets you download and install software automatically. It is not necessary to fill a [software repository](#) manually. But if you want to fill a software repository before running installations, you can use the *repository synchro-*

nization feature in the Installation Manager. For configuration details, see the "Installation Manager" help.

You can access the following resources on the Rohde & Schwarz Internet for downloading software and documentation updates.

**Table 3-1: Internet addresses for updates (registration required)**

Resource	Link/host	Section/folder	Port
GLORIS	<a href="https://gloris.rohde-schwarz.com">https://gloris.rohde-schwarz.com</a>	Support&Services > "My Products" > "MRT Customer Web"	–
SFTP	sft.rohde-schwarz.com	cmw_protocol_download	22
FTPS			990
WebDAV	<a href="https://sft.rohde-schwarz.com">https://sft.rohde-schwarz.com</a>		9443

For more information on accessing the Rohde & Schwarz download server, see the following website:

[https://gloris.rohde-schwarz.com/anonymous/en/pages/toplevel/sft\\_info.html](https://gloris.rohde-schwarz.com/anonymous/en/pages/toplevel/sft_info.html)



The ports for using SFTP/FTPS can be blocked in your company. If so, contact your local system administrator.

## 4 Installing and Starting the Application

Installation of the Installation Manager is necessary on PCs and all supported instruments that do not already run the Installation Manager.

### Installation hints

- The application is pre-installed on newly shipped instruments, including the following:
  - R&S CMW500 Protocol Tester and CMWcards Signaling Tester
  - R&S CMW290 CMWcards IoT Tester
  - R&S CMWC Multi-CMW Controller
  - System controller PC (as part of R&S CONTEST-based test systems)
- You need the right to install software on the instrument or PC where the application runs.
- In multi-CMW (LAN) setups (with R&S CMW-CU), run the same Installation Manager version on all connected instruments.

### To install and start the Installation Manager for the first time

Download the latest Installation Manager version from GLORIS at:

[https://gloris.rohde-schwarz.com/irj/portal/ccw\\_document?btxGuid=2039cd2a-bae7-3410-5087-8c2464195359](https://gloris.rohde-schwarz.com/irj/portal/ccw_document?btxGuid=2039cd2a-bae7-3410-5087-8c2464195359)

For download connection details, see [Chapter 3.6, "Download Resources"](#), on page 18.

1. Run the `InstallationManager_<version>.msi` installer file.
2. Follow the instructions on the screen.
3. During installation, keep the selection "Launch Application after Installation".  
The Installation Manager is installed. It starts up and the "Welcome" view opens in the default browser.

**Note:** If the "Welcome" view does not show up properly, check if an ad(vertisement) blocker prevents loading the Installation Manager. If so, set an exception for the Installation Manager. Press [F5] to reload the "Welcome" view.

4. Select the "Details" view.

The Installation Manager lists all mandatory software in its "Action List".

The Installation Manager is installed. The Installation Manager shows the "Installation Manager Monitor" icon in the Windows notification area (, service successfully running).

To complete initial installation, continue with ["To execute scheduled downloads and installations \(automatic download\)"](#) on page 29.

### To open Installation Manager in future sessions

1. Right-click the "Installation Manager Monitor"  in the Windows notification area.
2. Select "Open Installation Manager".

#### Result

The Installation Manager opens in the default browser.

## 5 Creating Repositories

As described in [Chapter 3, "Concepts"](#), on page 11, the Installation Manager uses software repositories and the Installation Manager database to keep all installations consistent.

The Installation Manager provides an initial software repository at first program start:

- If the Installation Manager is installed for the first time and a software repository is not present, the Installation Manager automatically creates a software repository here:  
`C:\Users\Public\Documents\Rohde-Schwarz\InstallationManagerRepository`
- When updating the Installation Manager, previous software repository settings are retained.

You can create your own software repositories. The Installation Manager can manage up to three independent software repositories which you can switch between. A newly created software repository is empty, so it is necessary that you first fill the repository with software installers.



### Path notation in shortcuts to remote computers

A software repository can contain shortcuts to other folders. If shortcuts point to shared folders on a network resource, Rohde & Schwarz recommends using the **UNC** syntax notation:

```
\\<ComputerName>\<SharedFolder>\  
<SoftwareRepositoryFolder>
```



You can skip the procedure of creating a software repository if it already exists. Often, a central software repository for many test instruments has already been established in the company network.

Continue with [Chapter 6, "Activating Repositories"](#), on page 24.

---

### To create a user-defined software repository

1. Open the Windows Explorer.
2. Create a folder that serves as software repository.

We recommend selecting a folder on the local hard disk drive. On a Rohde & Schwarz instrument, select drive D. However, you can also use any accessible storage location as shown in [Figure 3-2](#).

**Result**

A software repository is prepared. You can fill the folder with software installers provided in the Rohde & Schwarz internet for later installation.

For background information on download and additional options, see [Chapter 3.6, "Download Resources"](#), on page 18.

## 6 Activating Repositories

You can activate up to three independent software repositories. The Installation Manager considers all software installers within the activated software repositories, including those installers contained in subfolders or folders linked via short-cuts. You can specify and activate the software repositories in the "Settings" view, see the following figure.

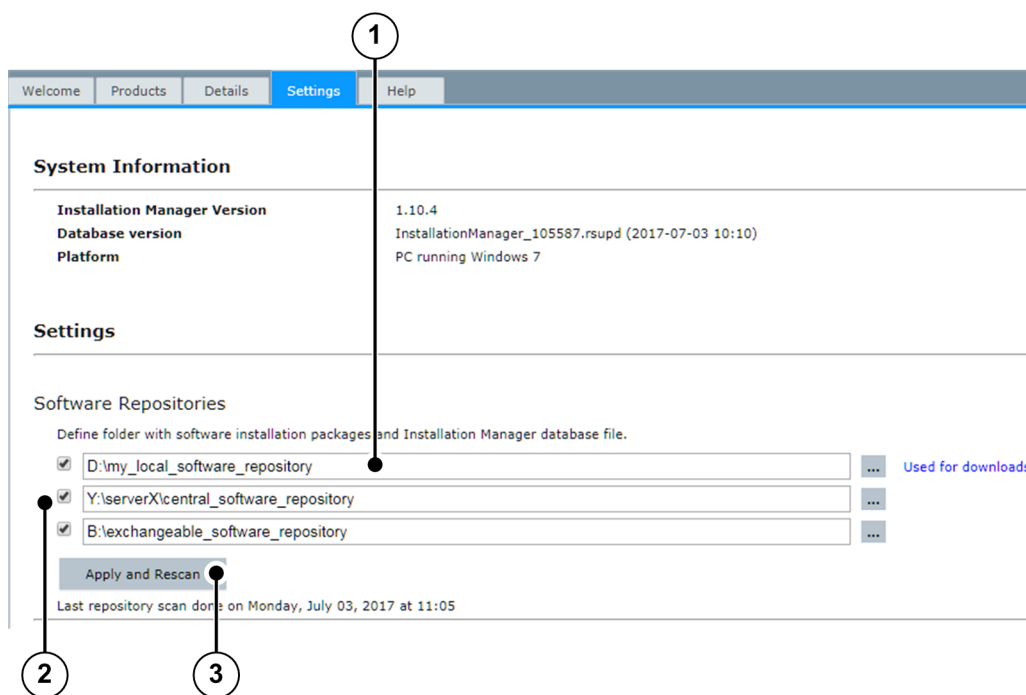

**Figure 6-1: Settings view – Activating software repositories**

- 1 = Full path to software repository
- 2 = Activates software repository (checkbox selected)
- 3 = "Apply and Rescan": Read in the software repositories and apply the selection



If no software repository is specified yet, the Installation Manager prompts you to do so.

### To activate a software repository

Prerequisite: You need write access to the folder where the first active software repository resides. This software repository is indicated by "Used for downloads". It is used as target folder for all software downloads from GLORIS.

1. Click "Settings".



2. Under "Software Repositories", specify the path to the software repository (1). You can browse for the folder or you can type or paste the path in one of the text boxes. In the folder browser, you can find a "Recent" list on the top. The list lets you select from latest connected folders.
3. Select the check box next to the software repository to activate it (2).
4. If you want to define a second or third software repository, repeat the previous steps for other folders.
5. Click "Apply and Rescan" (3).

All activated software repositories are scanned. All changes are detected and applied.

**Note:** The Installation Manager informs you if the folder is not existent or if the path is invalid. To resolve the problem, specify a suitable folder. The Installation Manager at least requires one valid software repository.

### **Result**

The software repositories are specified and up-to-date. You can keep the default values of all advanced settings in the "Settings" view.

## 7 Selecting Products and Actions

The Installation Manager automatically shows the "Products" view after clicking a category tile or after performing a search in the "Welcome" view. Furthermore, you can directly open the "Products" view, set categories on the left or search for a product. The result is then listed on the right, see the following figure.

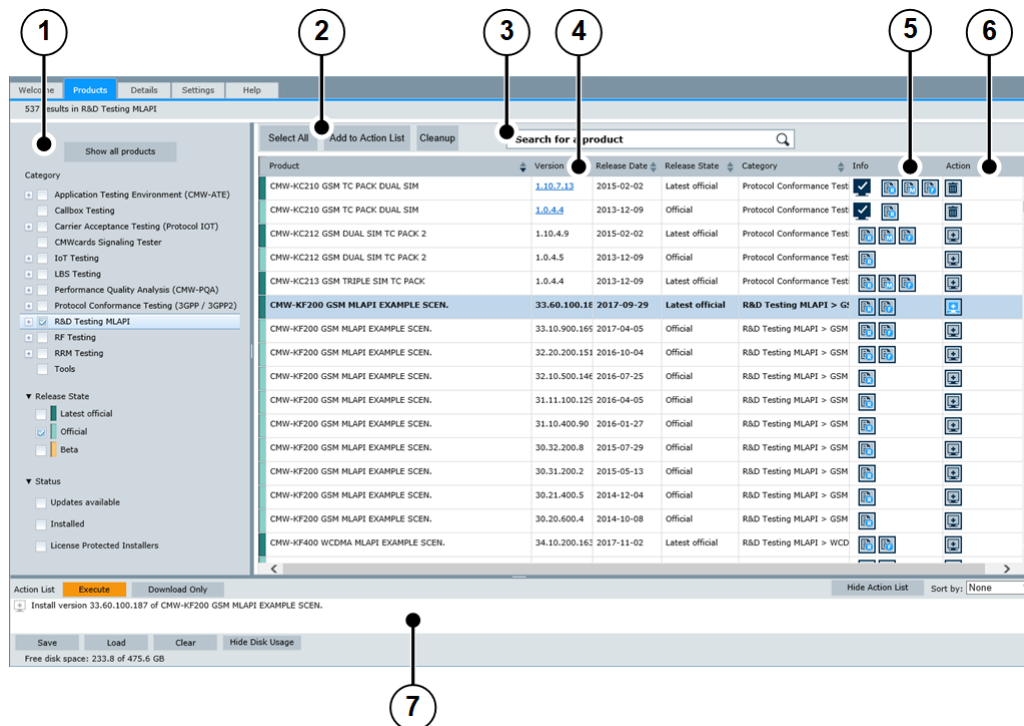

**Figure 7-1: Products view – product selection**

- 1 = Filter by category, release state and status
- 2 = Multiple selections: "Select All" and "Add to Action List"
- 3 = Search box: Type product name to start
- 4 = "Version" column: Shows versions and optionally links to folders where products have been installed
- 5 = "Info" column: Shows installation and licensing state; provides links to documentation
- 6 = "Action" column: Select product to add all components to the "Action List"
- 7 = "Action List": Initially hidden; available when a product has been selected via the "Action" column



- On R&S CMW290 CMWcards IoT Tester and R&S CONTEST system controller PC, only a subset of products are listed under "Category".
- The numbers in brackets in the following procedures refer to [Figure 7-1](#).

### To select a product

1. For defining or narrowing the product list, do one of the following:
  - Apply filter categories, for example, product category, release state and status (1).
    - or –
  - Directly search for a specific product (3).
2. Identify the desired products in the table.
3. Check the installation state for the products in the "Info" column (5).

Example states:

- "Installed" means that the product is already installed.
-  "Update available" means that an earlier version of the product is installed and updates are available.

**See also:** "Installation Manager" help, "Quick Reference"

4. Select the products.



#### Releasing the category filter

To release the current category filter settings in the "Products" view, click the "Show all products" button above the categories on the left. All installed, latest official versions out of all categories are shown.



---

### To schedule actions using "Add to Action List" button

1. Click the "Add to Action List" button (2).

Selected products with associated actions are added to the "Action List".
2. Inspect the scheduled actions in detail in the "Action List" (7).

### To remove a scheduled action from the Action List

- ▶ Click the action icon  again to cancel the selection of a product. The icon changes to .

#### Result

The actions associated with the product are removed from the "Action List".

## 8 Executing Scheduled Actions

All the products that are selected as an *action*, are scheduled in the "Action List": download, installation and uninstallation. The "Action List" also includes necessary dependent actions. You can now perform a bulk processing of the scheduled actions, see the following figure.

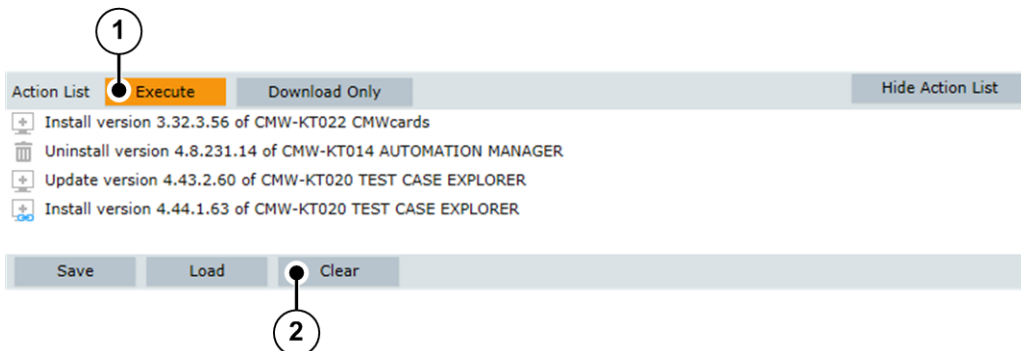

**Figure 8-1: Action List – actions to be performed**

- 1 = "Action List": "Execute" starts installation or prompts for download options  
2 = "Action List": "Clear" removes all actions from the list

### To execute scheduled actions

This procedure assumes that all required software installers are already present in the software repository; no download is necessary.



Close all running applications before you continue installation.

- ▶ Click "Execute" to perform all actions (1 in [Figure 8-1](#)).  
The Installation Manager starts processing the list. The Installation Manager indicates the installation progress and shows the information about the hard disk, see the following figure.

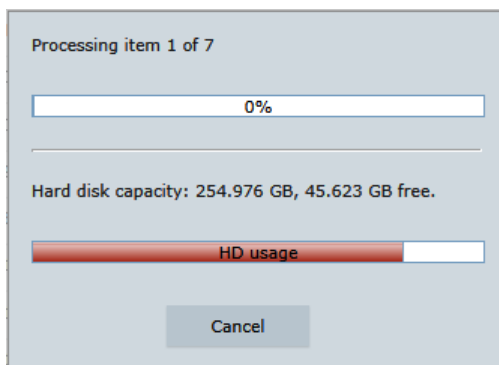

Figure 8-2: Action List – processing installations

## Result

The software installation is updated according to the selected actions.



### Software download requirement

You need write access to the folder where the first active software repository resides. This software repository is indicated by "Used for downloads". It is used as target folder for all software downloads from GLORIS.

### To execute scheduled downloads and installations (automatic download)

If downloads are necessary, the Installation Manager downloads missing software automatically right before installation.

1. Click "Execute" (1 in Figure 8-1).

"Execute" ensures that the Installation Manager performs all "download and installation" actions. Alternatively, you can select "Download Only" to perform installation later.

The Installation Manager shows the following dialog box in both cases.

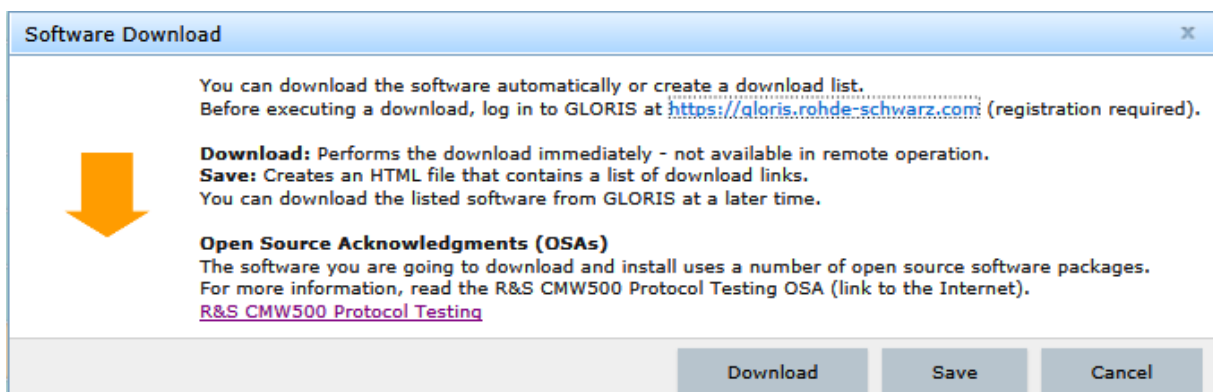
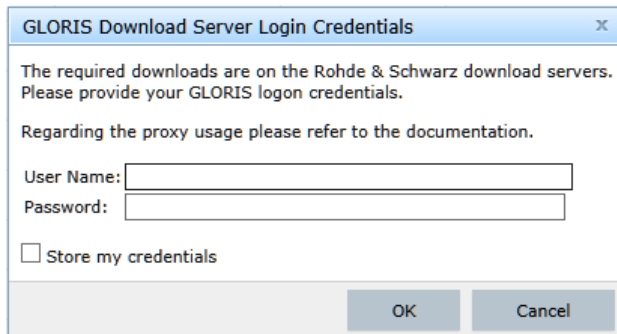

Figure 8-3: Selecting the download method

2. Click "Download".

The Installation Manager prompts you to provide your GLORIS credentials (e-mail address and password). You can save the settings for future Installation Manager sessions.



**Figure 8-4: Specifying GLORIS login credentials**

3. Click "OK".

The Installation Manager starts processing the "Action List". Processing covers verification of dependencies, downloading the software, scanning the software repository again and installing the software.

**Note:** If you are prompted to log in to GLORIS although you are already logged in, verify if the web browser blocks cookies. Specify a blocking exception for "gloris.rohde-schwarz.com" and retry.

### Result

The software installation is updated according to the performed actions. For information about saving the download list (manual download), see the "Installation Manager" help, "Advanced Tasks".

### To remove all scheduled actions

- ▶ Click the "Clear" button in the "Action List".

### Result

The "Action List" is cleared. You can start over.

See also ["To remove a scheduled action from the Action List"](#) on page 27.

For information about saving and loading an "Action List", see the "Installation Manager" help, "Advanced Tasks".

## 9 Contacting Customer Support

### Technical support – where and when you need it

For quick, expert help with any Rohde & Schwarz product, contact our customer support center. A team of highly qualified engineers provides support and works with you to find a solution to your query on any aspect of the operation, programming or applications of Rohde & Schwarz products.

### Contact information

Contact our customer support center at [www.rohde-schwarz.com/support](http://www.rohde-schwarz.com/support), or follow this QR code:



*Figure 9-1: QR code to the Rohde & Schwarz support page*

# Glossary: Abbreviations and Terms

## C

**CMW operating setup:** Short: CMW setup. Subset of [test equipment](#) in a CMW subnet. The [R&S CMW500](#) instruments in a CMW setup share same SysSync generator and reference frequency source.

**controller:** Generic term for both [R&S CMWC](#) and [R&S CMW-CU](#).

## D

**DVD:** Digital Versatile Disk

## F

**FTPS:** File Transfer Protocol using SSL or TLS

**FWA:** Denotes so-called "firmware applications", for example, CMW BASE, CMW Data Application Test Support and CMW Protocol Testing Support

## G

**GLORIS:** Global Rohde & Schwarz Information System. A secured and personalized part of the Rohde & Schwarz Internet services.

## H

**HTTP:** HyperText Transfer Protocol

**HTTPS:** HyperText Transfer Protocol Secure

## I

**IoT:** Internet of Things

## L

**LAN:** Local Area Network

**LAN mode:** Operating mode if only using the CMW subnet connections for controlling a multi-CMW test setup with the [R&S CMW-CU](#). See also [PCIe mode](#).



**M**

**MCC:** Multi-CMW Control. Rohde & Schwarz proprietary control connection type allowing for multi-CMW start-up procedures and license pooling.

**MRT:** Mobile radio tester

**P**

**PC:** Personal Computer

**PCIe:** PCI Express. Connection type between [R&S CMWC](#) and [R&S CMW500](#) allowing for highly performant communication solutions.

**PCIe mode:** Operating mode of the [R&S CMWC](#). This mode requires [PCIe](#) and [MCC](#) connections to the [R&S CMW500](#) in addition to the CMWsubnet connections. See also [LAN mode](#).

**platform:** Generic term that covers [PC](#) and [test equipment](#). Often used in the context of software update and licensing.

**protocol testing:** Generic term that refers to all testing activities on an R&S CMW500 Protocol Tester and on an R&S CMW500 CMWcards Signaling Tester.

**PT:** Protocol Tester

**R**

**R&S CMW-CU:** R&S CMW-CU Control Unit. A powerful computer that controls the test run in a [CMW operating setup](#). It only supports the [LAN mode](#).

**R&S CMW500:** R&S CMW500 Wideband Radio Communication Tester. Rohde & Schwarz solution for fast and precise testing of current and future mobile devices.

**R&S CMWC:** R&S CMWC Multi-CMW Controller. A powerful computer that controls the test run in a [CMW operating setup](#). It only supports the [PCIe mode](#).

**R&S CMX500:** The R&S CMX500 radio communication tester is the test platform extension for signaling in 5G NR frequency ranges FR1 and FR2 according to 3GPP TS 38.101.

**RAT:** Radio Access Technology

**S**

**SFTP:** SSH File Transfer Protocol

**software repository:** Storage location that contains the the software packages to be installed with the Installation Manager and the Installation Manager database (\* .rsupd).

**SSH:** Secure Shell

**SSL:** Secure Socket Layer

**SW:** software

**T**

**TCP:** [TCP/IP](#)

**TCP/IP:** Transport Control Protocol/Internet Protocol

**test equipment:** Generic term for main multi-CMW equipment: [R&S CMWC](#), [R&S CMW500](#) and [R&S CMW-CU](#).

**TLS:** Transport Layer Security

**U**

**UNC:** Universal Naming Convention – or – Uniform Naming Convention

**URI:** Uniform Resource Indicator

**USB:** Universal Serial Bus

# Index

- A**
- Action
    - Remove ..... 27
    - Scheduled ..... 28
  - Action List ..... 8
    - Clear ..... 30
    - Execute ..... 28
  - Activating
    - Software repository ..... 24
  - Automatic software download ..... 29
  - Automatic update
    - Database ..... 16
    - Installation Manager ..... 16
- C**
- Clear Action List ..... 30
  - Concepts ..... 11
  - Conventions, typographic ..... 6
  - Creating, software repository ..... 22
  - Customer support ..... 31
- D**
- Dependency, to other software ..... 14
  - Documentation, overview ..... 5
- E**
- Executing Action List ..... 28
- F**
- Features ..... 8
  - FTPS ..... 19
- G**
- GLORIS ..... 18, 19
- I**
- Installation Manager
    - Automatic update ..... 16
    - Concepts ..... 11
    - Database ..... 14
    - Database update ..... 16
    - Installing ..... 20
    - Launching ..... 20
    - Starting ..... 20
    - Updating ..... 20
  - Installing Installation Manager ..... 20
- K**
- Key features ..... 8
  - Key symbol
    - Meaning ..... 17
- L**
- Launch Installation Manager ..... 20
  - License
    - Managing ..... 17
  - License Proxy ..... 17
- P**
- Products view ..... 8, 26
- R**
- R&S Installation Manager, service ..... 18
  - Remove an action ..... 27
  - Repository, for software ..... 11
  - Resource, for downloads ..... 18
- S**
- Scheduled actions ..... 28
  - Selecting
    - Actions ..... 26
    - Products ..... 26
  - Service, InstallationManager ..... 18
  - SFTP ..... 19
  - Software download, automatic ..... 29
  - Software repository
    - Activate ..... 24
    - Creating ..... 22
    - Filling ..... 12
    - General ..... 11
    - Updating ..... 12
  - Starting Installation Manager ..... 20
- T**
- Task, scheduled ..... 28
  - Typographic conventions ..... 6
- U**
- Updating Installation Manager ..... 20

**V**

## View

Products .....	8
Welcome .....	7

**W**

WebDAV .....	19
Welcome view .....	7