

R&S®ATS-TEMP

Climate Option for R&S®ATS1000

User Manual



117827502

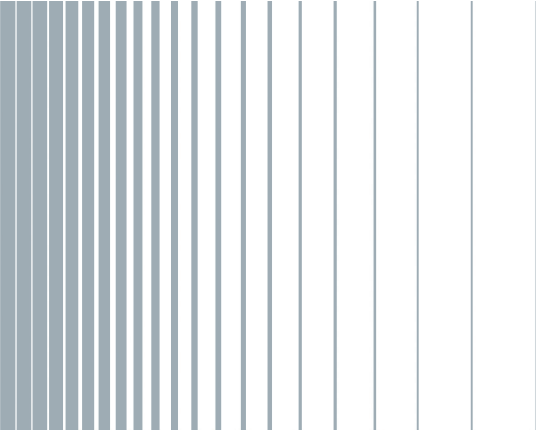

This document describes the R&S®ATS-TEMP, order no. 1533.8147.02.

© 2018 Rohde & Schwarz GmbH & Co. KG

Mühlhofstr. 15, 81671 München, Germany

Phone: +49 89 41 29 - 0

Fax: +49 89 41 29 12 164

Email: info@rohde-schwarz.com

Internet: www.rohde-schwarz.com

Subject to change – Data without tolerance limits is not binding.

R&S® is a registered trademark of Rohde & Schwarz GmbH & Co. KG.

Trade names are trademarks of the owners.

1178.7275.02 | Version 03 | R&S®ATS-TEMP

The following abbreviations are used throughout this manual: R&S® is abbreviated as R&S.

Contents

1	Safety Instructions	5
1.1	Intended Use.....	5
1.2	Requirements for Safe Operation.....	5
1.3	How to Prevent Risks.....	6
1.4	Safety Labeling.....	7
2	Product Description	8
2.1	Key Characteristics.....	8
2.2	Delivery.....	10
2.3	Product Overview.....	12
3	Putting into Operation	15
3.1	Test Setup.....	15
3.2	Connecting to Thermal Air-Stream Device.....	17
3.3	Preparing the DUT.....	19
3.4	Calibrating.....	21
4	Performing Measurements	25
5	Troubleshooting	27
	Glossary	28
	Index	30

1 Safety Instructions

Setup and operation of an R&S ATS-TEMP implies risks of severe injury:

- Burns caused by hot steam
- Burns caused by hot surface
- Frostbite caused by cold surface
- Intoxication caused by toxic fumes
- Injury caused by explosion of explosive gases
- Risks due to operation of a thermal device
- Risks due to operation of the R&S ATS1000 antenna test system

To reduce these risks and prevent accidents, carefully read the following chapters and all related user manuals and safety instructions.

Keep the product documentation in a safe place and pass it on to subsequent users.

1.1 Intended Use

The R&S ATS-TEMP is intended to be used within the R&S ATS1000 antenna test system. It allows measurement of RF characteristics of the DUT while exposed to temperatures between -20 °C to 85 °C.

The climate option for R&S ATS1000 has been manufactured in accordance with accepted engineering practices and the latest scientific and technical findings. The R&S ATS-TEMP has undergone many hours of testing and complies with relevant safety regulations when operated properly. There are, due to the covered temperature range, still dangers involved, even when the product is operated as intended.

1.2 Requirements for Safe Operation

- Installation
Make sure that the R&S ATS-TEMP is installed into the R&S ATS1000 by Rohde & Schwarz personnel, either on site or at the Rohde & Schwarz plant.
- Personnel
Make sure that only personnel familiar with the potential risks of temperature and environmental testing operates the R&S ATS-TEMP.
- Operating Area
Ensure that only personnel familiar with the potential risks of temperature and environmental testing enters the operating area.
Ensure that the operating area is kept free of flammable objects and is tidy.
- Operation
Ensure that during operation of the climate option for R&S ATS1000, all safety regulations and operating instructions are adhered to strictly.

Observe applicable local or national safety regulations and rules for the prevention of accidents.

Ensure that R&S ATS-TEMP, hoses, and adaptors are well-sealed before operation inside R&S ATS1000.

Ensure that the personnel wear protective clothing (work clothes and gloves).

Disconnect the DUT from power before touching/removing it from R&S ATS-TEMP.

Use the R&S ATS-TEMP only for its intended use and within its performance limits.

If you are unsure about the appropriate use, contact Rohde & Schwarz service.

- Environmental condition
Observe the operating conditions specified in the data sheet.
- R&S ATS-TEMP condition
Use the R&S ATS-TEMP only if it is in excellent condition. If you detect or suspect any irregularities, malfunctions, damage, or temperature leakage; immediately stop using the R&S ATS-TEMP and inform Rohde & Schwarz for a service check.
- Modifications
Never change or modify the climate option for R&S ATS1000 or make additions that can affect safety.
- Safety stickers
Do not remove the safety stickers on the outside of the bottom shell of the R&S ATS-TEMP. Always keep the stickers visible.
If the stickers peel off, you must replace them. Contact Rohde & Schwarz local support to order new stickers.

1.3 How to Prevent Risks

How to prevent burns caused by hot steam

When opening the R&S ATS-TEMP, hot steam can escape and scald you.

To prevent burns:

- ▶ Wait until the surface of the dome of R&S ATS-TEMP is at room temperature before opening and use heat/cold resistant gloves.

How to prevent burns or frostbite caused by hot or cold surface

Depending on operation during extreme temperature testing, the surfaces of the OTA Bubble, mast, hoses, and the DUT can be very hot or very cold. You can suffer from burns or frostbite, if you touch these surfaces. Especially, be aware that your fingers can freeze to a surface at temperatures below 0° C.

To prevent burns and frostbite:

- ▶ Allow the R&S ATS-TEMP to adjust to room temperature before touching.
- ▶ Use heat/cold resistant gloves when touching any hot or cold parts.

How to prevent intoxication and injury due to explosion

When loading the R&S ATS-TEMP with an unsuitable DUT, toxic or explosive gases can be produced. These gases can cause the R&S ATS-TEMP to explode and injure you. Toxic fumes can escape and lead to intoxication.

To prevent the formation of dangerous gases:

- ▶ Load the R&S ATS-TEMP only with materials/DUTs which do not form any toxic or explosive vapors when heated up.

How to prevent risk of injury due to operation of a thermal device





Operating a thermal device includes risks of temperature-related injuries.

To prevent these risks:

- ▶ Carefully read the safety instructions of the thermal device used.
- ▶ Limit the thermal device to the temperature range from -60°C to $+105^{\circ}\text{C}$.
Temperatures outside of this range can damage the equipment and lead to injuries. Note that the R&S ATS-TEMP and the R&S ATS1000 do not control the thermal device. Therefore, temperature limitation is in your responsibility.

1.4 Safety Labeling

Safety labels on the product warn against the potential hazards.

	Hot surface Do not touch. Keep the operation area dust-free. Risk of skin burns. Risk of fire.
	Cold surface Do not touch. Risk of frostbite.
	Electrical hazard Indicates live parts. Risk of electric shock.
	Danger of hot vapors or scaling Load the R&S ATS-TEMP only with materials/DUTs which do not form any toxic or explosive vapors when heated up.

2 Product Description

The R&S ATS-TEMP is a climate option for R&S ATS1000. This Rohde & Schwarz product allows 3D RF measurements of antenna characteristics in a temperature range from -20 °C to 85 °C to analyze temperature effect on the chipset and UE performance. The provided measurement conditions are suitable for tests at extreme temperatures and extreme temperature ranges.

The R&S ATS-TEMP operates mounted in an antenna test system R&S ATS1000. A current version of R&S ATS1000, which has a false-floor plate with predefined holes in it, supports the climate option for R&S ATS1000. A retrofit of an older R&S ATS1000 chamber to this thermal solution must be performed by Rohde & Schwarz service.

The R&S ATS-TEMP is designed for operation with thermal test device to be connected to the hose adaptors of the R&S ATS-TEMP. The thermal test device uses hot or cold airstream. It controls the temperature via its temperature sensors placed in the R&S ATS1000 chamber.

Rohde & Schwarz recommends the thermal device TA-5000A to be used with R&S ATS-TEMP. With this thermal test device, all connectors match.

This user manual contains a description of the functionality that the R&S ATS-TEMP provides. The latest version is available for download at the product homepage (www.rohde-schwarz.com/product/ats1000).

2.1 Key Characteristics

The R&S ATS-TEMP consists of an RF transparent material which minimizes the influence to the radiated measurements (< -1dB for 5G NR for 22 GHz to 45 GHz). Due to its compact design, the R&S ATS-TEMP results in fast and precise 3D measurements with excellent repeatability and angular resolution.

The key characteristics of the R&S ATS-TEMP are the following:

Table 2-1: Specification

Parameter	Value	Comments
Outer dimensions	30 cm	Diameter
Inner dimensions (max. DUT size)	22 cm x 22 cm	
Operational temperature range	-20 °C to 85 °C	Possible to go to -40 °C for short periods (less than five minutes)
Minimum soak time for extreme temperatures before cooling/heating cycle	3 minutes	
Maximum soak time for extreme temperatures	Dependent on the temperature outside R&S ATS-TEMP	If the ambient temperature outside R&S ATS-TEMP is above 40 °C, perform a cold temperature cycle to cool the OTA Bubble.

Parameter	Value	Comments
Software interface	None provided; control the thermal test device via its user interface	Set the temperature limits of the thermal device to -60°C and +105°C
Operational frequency range	23.5 GHz to 44.3 GHz	Can be operated outside this frequency range. Operational range is range in which RF loss/phase difference achieved.
RF loss of the dome at room temperature	< -1 dB	S21 path loss measurement at boresight with high gain horn antenna.
Phase difference of the dome at room temperature	< 5 degrees per GHz (slope of phase difference line)	S21 measurement at boresight with high gain horn antenna.
Hose adaptor interface	1/2 NPT hose	Refer to MPI Thermal
External temperature sensors	Two required: inside and outside the OTA Bubble	Part of thermal test device

For a detailed specification, refer to the data sheet.

Temperature Operation and Condensation

You can heat up the interior of R&S ATS-TEMP to 85 °C and cool down to -20 °C.

To prevent condensation, the system has several features:

- Sealed hose and adaptors from thermal test device to R&S ATS-TEMP.
- Patented [OTA Bubble](#) design to minimize condensation on outside of the OTA Bubble.
- Internal drainage for condensation in the OTA Bubble through the hose for air out.
- In addition, we recommend using a thermal test device that removes humidity from the airstream before going into the R&S ATS-TEMP.

After repeated hot/cold cycles, use a soft cloth to absorb any water condensation in and around the OTA Bubble, hoses, and mast. Place a small bowl at the R&S ATS1000 air out hose adaptor on the lower right side to catch the water. Alternatively, attach another hose to the air out hose adaptor to vent the cooled/heated air and condensation to another location.

2.2 Delivery

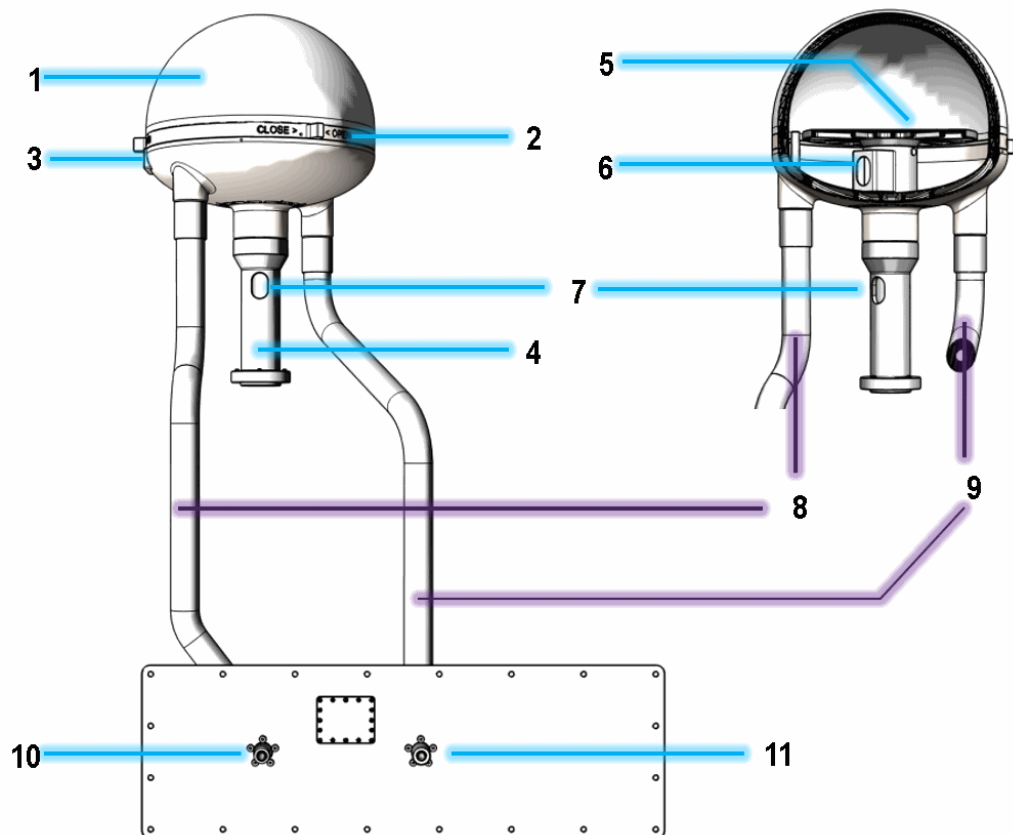

Figure 2-1: R&S ATS-TEMP components

- 1 = Dome of OTA Bubble
- 2 = Locking grip (part of dome)
- 3 = Bottom shell of OTA Bubble
- 4 = Mast
- 5 = DUT holder
- 6 = Cable feedthrough part, inner hole
- 7 = Outer hole (part of mast)
- 8 = Hose (air in)
- 9 = Hose (air out)
- 10 = Hose adaptor (air in)
- 11 = Hose adaptor (air out)

Inspecting the contents

The delivery package contains the following items:

- Dome (1) with locking grip (2) and bottom shell (3), jointly the **OTA Bubble**
- Mast (4) with two holes (6, 7) fastened via four metal screws to the turntable of R&S ATS1000
- Cable feedthrough part (6) with inner hole
- **DUT holder** (5) with a plastic cap in the middle. The **DUT holder** is fastened via four plastic screws to the mast

- Air hoses (8, 9) connected to the OTA Bubble via bayonet thread.
- Plate with hose adaptors (10, 11), 1/2 NPT female connectors (diameter 40 mm), possible opening for temperature sensors
- User manual

Inspect the package for damage

Keep the package and the cushioning material until the contents have been checked for completeness and the device has been tested.

If the packaging material shows any signs of stress, notify the carrier and your Rohde & Schwarz service center. Keep the damaged package and cushioning material for inspection.

Inspect the product

If the content is incomplete, damaged, or defect or if the R&S ATS-TEMP climate option for R&S ATS1000 does not operate properly, notify your Rohde & Schwarz service center.

Calibration certificate

The calibration certificate is not included in the standard shipping. The calibration is described in [Chapter 3.4, "Calibrating"](#), on page 21.

Additional equipment

The following required equipment is not included in the order number of an R&S ATS-TEMP. It must be also ordered:

- **R&S ATS1000**
Rohde & Schwarz delivers the R&S ATS-TEMP mounted in an R&S ATS1000. Only the service personnel of Rohde & Schwarz is authorized to retrofit the former versions of R&S ATS1000 to support the R&S ATS-TEMP.
To mount the R&S ATS-TEMP into the R&S ATS1000 or to remove it from the R&S ATS1000, contact Rohde & Schwarz service.
- **Thermal test device** with hoses and two external temperature sensors:
Rohde & Schwarz recommends [TA-5000A](#) to be used with R&S ATS-TEMP. With this thermal test device, all connectors match.
- **Measurement instruments:**
 - Signal analyzer (for example, [R&S ZVA](#) or [R&S FSW](#)) for **DUT** transceiver measurements: channel power, [EVM](#), [ACLR](#), [SEM](#), etc.
 - Signal generator (for example [R&S SMW200](#)) for passive **DUT** measurements.
- **R&S OSP:**
Switch box for automated/controlled switching between measurement instruments.
- **Cables** to the **DUT** for charging, RF connection, control IF, etc., if necessary.

2.3 Product Overview

The R&S ATS-TEMP consists of the following components:

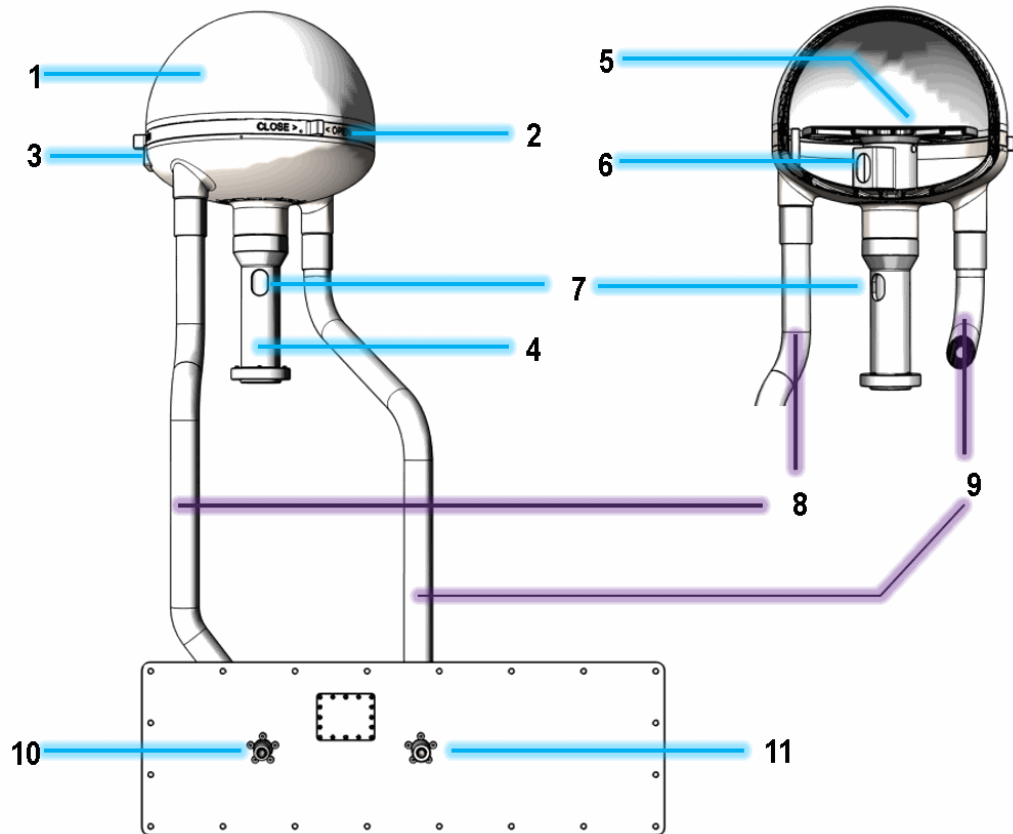

Figure 2-2: R&S ATS-TEMP components

- 1 = Dome (removable) of OTA Bubble
- 2 = Locking grip
- 3 = Bottom shell of OTA Bubble
- 4 = Mast
- 5 = DUT holder
- 6 = Cable feedthrough part, inner hole
- 7 = Outer hole
- 8 = Hose (air in)
- 9 = Hose (air out)
- 10 = Hose adaptor (air in)
- 11 = Hose adaptor (air out)

- **Dome**

Dome is a removable RF transparent component. It is made of ROHACELL®, material with outstanding thermic stability. It deteriorates after roughly 500 to 1000 hours of extreme temperature testing (hours of usage depend on temperature ramps and times). Contact Rohde & Schwarz for replacements.

- **Locking grip**

The plastic locking grip is attached to the dome. For fastening to the dome, match the position of dots at the dome and the bottom shell, then rotate to the right. To

loosen and remove the dome, rotate to the left. Do not remove the locking grip from the dome.

- **Bottom shell**

The bottom shell is a static component. It houses the rotating **DUT** holder and locks the dome during the tests.

Ensure that warning stickers placed at the bottom shell are always visible and heeded during and after operation.

- **Mast**

The mast is connected to the R&S ATS1000 turntable with four metal screws.

Wear heat resistant gloves when touching the metal screws after an extreme temperature testing.

The mast rotates during tests. For precise rotation of positioner, keep temperature in this area below 40 °C. If necessary, add additional insulation into the mast to prevent overheating.

- **DUT holder**

The **DUT** holder is drilled, to provide many possibilities to fasten the **DUT**. Use only plastic screws or bolts to fasten the **DUT**. Metal screws influence and corrupt the measurement results. Use a plastic cap in the middle, to avoid temperature losses. The holder rotates during tests.

- **Cable feedthrough part and inner hole**

The cable feedthrough part with a hole (matching with the upper hole in the mast) for cabling to the **DUT**

- **Outer hole**

Lower hole in the wall of mast for cables to the **DUT**. Preferably, use the inner space of the mast tube to conduct cables through to the **DUT**.

This section can become very hot or very cold immediately after testing. Avoid touching this area until the **DUT** and R&S ATS1000 have cooled down to ambient temperature.

- **Air in hose**

Hose from the thermal test device hose adaptor (air in) into the OTA Bubble. Be careful touching the section of the hose entering into the OTA Bubble as this joint can get very hot or very cold during and immediately after extreme temperature testing.

To fasten, rotate the hose in counterclockwise direction. To loosen, rotate the hose in clockwise direction.

- **Air out hose**

Hose from the OTA Bubble to the R&S ATS1000 hose adaptor (air out). Be careful touching the section of the hose exiting the OTA Bubble as this joint can get very hot or very cold during and immediately after extreme temperature testing.

To fasten, rotate the hose in counterclockwise direction. To loosen, rotate the hose in clockwise direction.

- **Plate with hose adaptors**

The plate on the lower left side of the R&S ATS1000 is equipped with:

- Hose adaptors (10, 11) - 1/2 NPT female connectors of diameter 40 mm - and
- A rectangle cover plate for feedthrough of temperature sensors

Hose adaptor (10) is used to connect a thermal test device via a hose (air in) to the OTA Bubble. Be careful touching the metal hose adaptor as this joint can get very hot or very cold during and immediately after extreme temperature testing.

Hose adaptor (11) between the air out hose from the OTA Bubble to the outside of the OTA Bubble. If necessary, place a container here to catch condensation, or attach another hose to ventilate the air to another location.

3 Putting into Operation

The R&S ATS-TEMP climate option for R&S ATS1000 has been designed to withstand a moderate amount of physical and temperature stress. Treat the product with care. It can be damaged if excessive force is applied.

NOTICE

Risk of instrument damage due to mechanical shock

Exercise care to prevent the product from receiving mechanical shock.

Always handle the product by the delivered hoses.

Avoid putting excessive strain on the product or exposing it to sharp bends.

During operation, the product heats up. This behavior is normal and not a sign of malfunction.

The following topics are covered in the next sections:

- [Test Setup](#)..... 15
- [Connecting to Thermal Air-Stream Device](#).....17
- [Preparing the DUT](#)..... 19
- [Calibrating](#).....21

3.1 Test Setup

The following figure shows the test setup for testing under extreme temperature conditions with R&S ATS-TEMP, including additional required equipment.

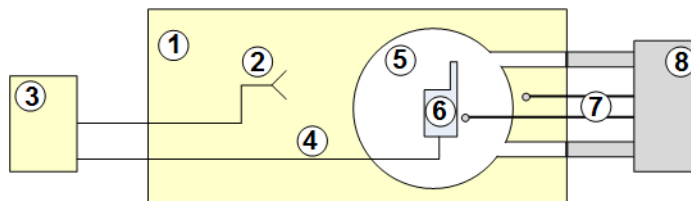

Figure 3-1: Test setup

- 1 = Antenna test system R&S ATS1000
- 2 = Test antenna (a part of R&S ATS1000)
- 3 = Rack with test instruments (part of R&S ATS1000 setup)
- 4 = RF connection (passive DUT only)
- 5 = OTA Bubble
- 6 = DUT
- 7 = Temperature sensors (part of thermal test device)
- 8 = Thermal test device

The R&S ATS1000 (1) is a test chamber with a moving test antenna (2). Its position and RF signals are controlled and post-process by test instruments typically mounted in a rack (3). Such a rack typically contains:

- Antenna positioning controller Maturo NCD
- Measuring receiver as
 - Signal and spectrum analyzer (for example [R&S FSW](#)) or
 - Vector network analyzer (for example [R&S ZVA](#))
- Vector signal generator for (for example [R&S SMW200](#)) used for an RF connection (4) to feed a passive DUT
- Switch unit (for example [R&S OSP](#)) for automated/controlled switching between measurement instruments

The R&S ATS-TEMP (5) is an RF transparent thermal chamber (OTA Bubble). It can be easily mounted into the R&S ATS1000 (1). It stabilizes a rotating DUT (6) for 3D measurements and contains thermal hoses for air circulation between the R&S ATS-TEMP and a thermal test device (8). The thermal test device controls test temperature cycles. The R&S ATS-TEMP enables the thermal test device to place external temperature sensors (7) inside and outside the OTA Bubble.

There are two recommended setups for R&S ATS-TEMP:

- [Device Cooling Test Setup](#)..... 16
- [High Temperatures Test Setup](#)..... 17

3.1.1 Device Cooling Test Setup

Device cooling can be performed with or without dome.

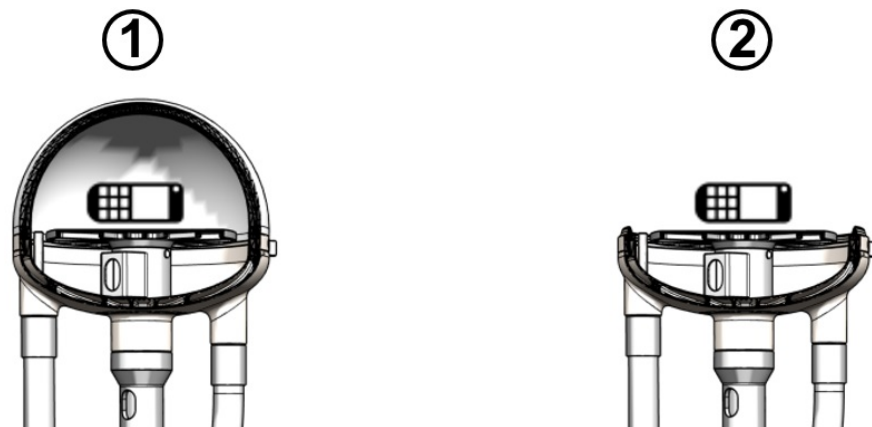

Figure 3-2: Setup: DUT cooling

- 1 = Self-enclosed (faster cooling)
- 2 = Open (no RF losses)



Use the open OTA Bubble only for cooling temperatures close to the ambient temperature.

It takes longer to cool down the DUT than if the OTA Bubble encloses the DUT, but there are lower RF path losses (see [Chapter 3.4.1, "Path Loss"](#), on page 21).

For a detailed description of R&S ATS-TEMP components, see [Chapter 2.3, "Product Overview"](#), on page 12.

For a list of additional equipment, see [Chapter 3.1, "Test Setup"](#), on page 15.

3.1.2 High Temperatures Test Setup

High temperatures measurements require a test setup with sealed dome.



Figure 3-3: Setup: high temperature testing



For high temperatures, the dome must be sealed. With a removed dome, high temperature can damage the antenna test chamber R&S ATS1000.

For a detailed description of R&S ATS-TEMP components, see [Chapter 2.3, "Product Overview"](#), on page 12.

For a list of additional equipment, see [Chapter 3.1, "Test Setup"](#), on page 15.

3.2 Connecting to Thermal Air-Stream Device

⚠ WARNING

Risk of injury due to operation of thermal device

Operating a thermal device includes certain risks of injuries. To prevent these risks, carefully read the safety instructions of the thermal device used.

NOTICE**Risk of equipment damage due to extreme temperatures of thermal devices**

Depending on the thermal test device that you use, the device's **temperature limits** can be far outside of the specified temperature range for the R&S ATS-TEMP. For example, the temperature range of the [TA-5000A](#) is -100 °C to +300 °C.

Exposing the R&S ATS-TEMP and the R&S ATS1000 to these extreme temperatures can damage your equipment. For example, polymer materials in your equipment can melt.

Note that the R&S ATS-TEMP and the R&S ATS1000 do not control the temperature limits of any external thermal device.

To avoid the risk of damage, make sure to **limit the output temperatures** of the thermal test device to the range from **-60 °C to +105 °C**. These settings allow operating the R&S ATS-TEMP in its specified temperature range from -20 °C to +85 °C (and down to -40 °C for <5 minutes).

There are several thermal test devices on the market.

Recommendation for features of thermal air-stream device:

- Operating temperature range at least -60 °C to 105 °C
- Automated temperature cycling
- Temperature control via at least two temperature sensors
- Frost-free test environment via dry air (nominal humidity 45%)

Rohde & Schwarz recommends the thermal device [TA-5000A](#) to be used with R&S ATS-TEMP. With this thermal test device, all connectors match.

To connect the [TA-5000A](#) to the R&S ATS-TEMP, proceed as follows:

1. To connect the flexible air hoses of the [TA-5000A](#) via bayonet thread to the hose adaptors, push and rotate to the right.
2. Remove the rectangle cover plate from the plate with hose adaptors.
3. Conduct two temperature sensors (labeled (7) in [Figure 3-1](#)) through the rectangular opening in the plate with hose adaptors.
4. Leave one sensor at the bottom of R&S ATS1000 near the mast.
If you use the [TA-5000A](#), select temperature sensor "T" for this position.
5. Conduct another temperature sensor through the opening in the bottom shell all the way up into the OTA Bubble (red arrow in [Figure 3-4](#)).
If you use the [TA-5000A](#), select temperature sensor "K" for this position.

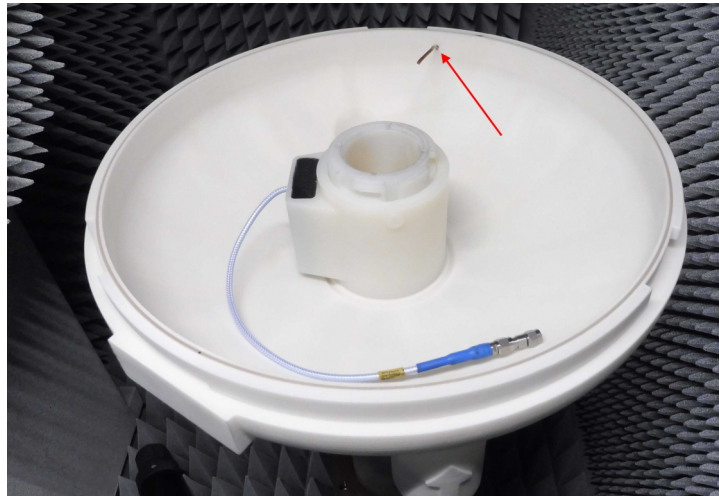

Figure 3-4: Position of temperature sensor K in the OTA Bubble

6. If you use the [TA-5000A](#), let it use temperature sensor "K" for temperature adjustment.

This selection avoids damage to the R&S ATS-TEMP and to the R&S ATS1000 that can result from using the wrong temperature sensor.

7. Set the **minimum temperature** of the thermal device to **-60 °C**.
8. Set the **maximum temperature** of the thermal device to **+105 °C**.

These settings allow operating the R&S ATS-TEMP in its specified temperature range from -20 °C to +85 °C (and down to -40 °C for <5 minutes).

3.3 Preparing the DUT

⚠ WARNING

Risk of intoxication and injury due to explosion

When loading the R&S ATS-TEMP with an unsuitable DUT, toxic or explosive gases can be produced. These gases can cause the R&S ATS-TEMP to explode and injure you. Toxic fumes can escape and lead to intoxication.

To prevent the formation of dangerous gases, load the R&S ATS-TEMP only with materials/DUTs, which do not form any toxic or explosive vapors when heated up.



Fasten and connect the DUT as follows:

1. Let us presume, the R&S ATS-TEMP is in delivered status. Make sure, its temperature is ambient.
2. Remove the dome, DUT holder and the cable feedthrough part.
3. If you use no DUT cables, continue with [step 3](#).
4. To establish the connections (RF, USB...) with the DUT, connect the cables to the interface inside the turntable of antenna test chamber. Refer to the user manual of R&S ATS1000, section Connecting a DUT in the Chamber.
5. Conduct the needed cables upwards inside the mast and through the inner hole of the mast positioned in the OTA Bubble.
Preferably, use the inner space of the mast tube to conduct cables to the DUT. If some cables do not fit into the mast, use the outer hole of mast.
6. Conduct the cables through the hole of cable feedthrough part. Mount the cable feedthrough part at the top of the mast.
7. Mount the DUT holder. Stabilize it via four plastic screws. Cover the opening in the middle by a delivered cap.
8. Connect the cables (RF, power, USB...) to the DUT.
9. Stabilize the DUT at the holder via plastic screws or bolts.
10. Fix the temperature sensor at the DUT holder near the DUT.
11. To place the dome correctly, match the dots of the dome and the bottom shell. To fix it via bayonet thread, rotate to the right.

3.4 Calibrating

There are two types of calibration required for proper use of R&S ATS-TEMP:

- **RF calibration** is a conventional path loss measurement to quantify the effect of the R&S ATS-TEMP as a function of frequency. See [Chapter 3.4.1, "Path Loss"](#), on page 21.
- **Thermal calibration** is a new type of OTA calibration. It requires an external temperature reference to calibrate the temperature sensors purchased separately in addition to the temperature effects on cables for passive measurements. See [Chapter 3.4.2, "Temperature Calibration"](#), on page 23.

For calibration purposes, it is assumed that all RF signals are continuous wave (CW) or swept frequency.

3.4.1 Path Loss

To perform this calibration, use one of the antenna measurement software packages: [R&S AMS32](#) or [R&S QS-ATSCAL](#) (R&S QuickStep) using a reference antenna with and without the dome of the R&S ATS-TEMP using a vector network analyzer (VNA), e.g., [R&S ZVA](#) or [R&S FSW](#) and vector signal generator [R&S SMW200](#) ([Figure 3-5](#)):

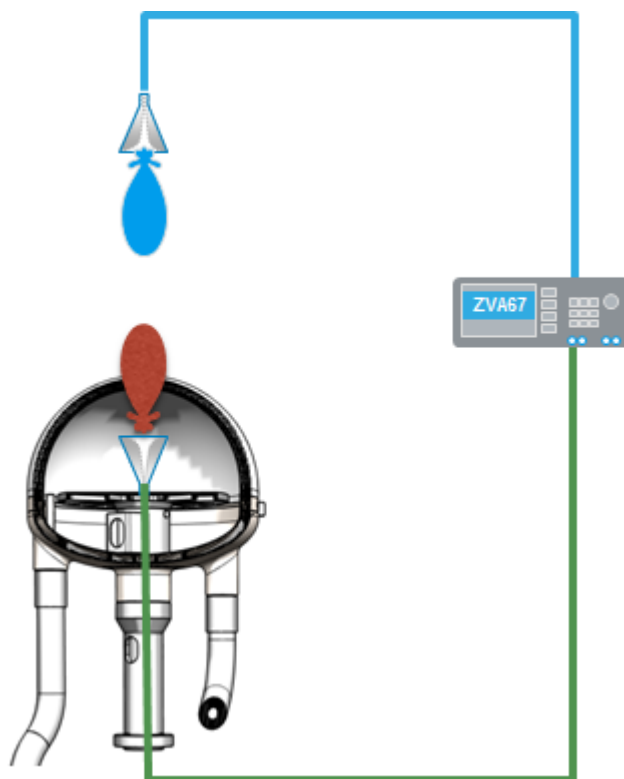

Figure 3-5: Gain calibration setup

1. Place the reference horn at the center of the DUT holder inside the R&S ATS-TEMP.
Direct the main antenna aperture upwards, toward the measurement antenna (in the boresight of the antennas).
2. To remove the dome of R&S ATS-TEMP, first rotate the dome by locking grip to the left.
3. Connect the VNA as follows:
 - Connect one port of the VNA via RF cable to the reference antenna at the DUT holder.
 - Connect the second (and third) port to the first (second) polarization of an RF test antenna at the top of the elevation arm.
4. Perform a S21 (and S31 for second polarization) measurement of amplitude over the desired frequency range.
5. Store the data into a file.
6. Place the dome of R&S ATS-TEMP matching two dots at the bottom shell and the dome.
The reference antenna is inside the OTA Bubble.
7. To lock the dome, rotate it to the right.
8. Repeat [step 4](#).
9. Store the data into the S21 . . . (S31 . . .) calibration log file.
The difference between the two measurements is the amplitude calibration coefficient.
10. Use the calibration log file S21 . . . (S31 . . .) in a measurement receiver (VNA), to compensate the error.

Figure 3-6 shows the results of a sample calibration procedure:

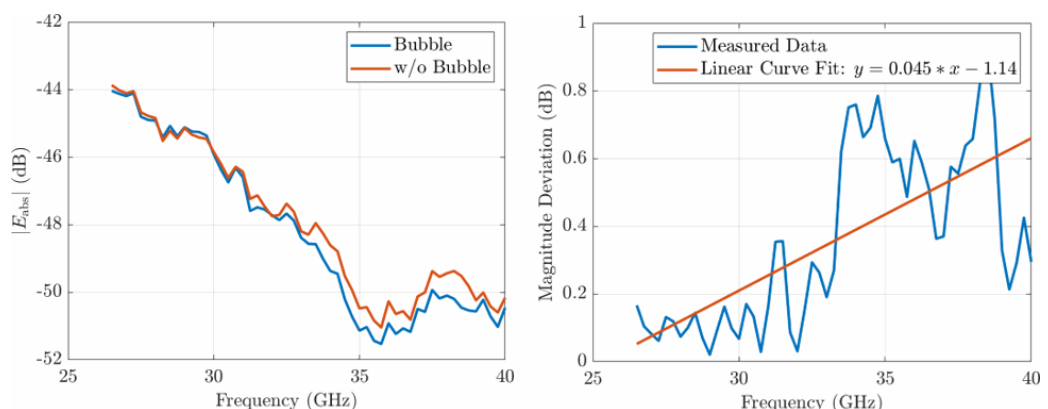

Figure 3-6: Amplitude difference in the calibration measurement

Left chart, blue line = Measured magnitude with OTA Bubble in place
Left chart, red line = Measured magnitude without OTA Bubble
Right chart, blue line = Magnitude deviation (dB), measured difference with/without OTA Bubble
Right chart, red line = Linear curve fit: $y = 0.045 * x - 1.14$

3.4.2 Temperature Calibration

WARNING

Risk of burns caused by hot steam or hot surface

During extreme temperature testing, the surfaces of the OTA Bubble, mast, hoses, and the DUT can be very hot. You can suffer from burns if you touch these surfaces.

To prevent burns, allow the R&S ATS-TEMP to adjust to room temperature before touching.

When opening the R&S ATS-TEMP, hot steam can escape and scald you. To prevent injury, wait until the surface of the dome of R&S ATS-TEMP is at room temperature before opening. Use heat resistant gloves when touching any hot parts.

For passive measurements using Teflon-based cables, perform a temperature calibration, due to the different electrical length and attenuation of the Teflon-based cable in different temperature conditions.

We recommend keeping the cable inside the R&S ATS-TEMP as short as possible.

For calibration measurements, use [R&S AMS32](#), [R&S CONTEST](#), or [R&S QS-ATS-CAL](#) (R&S QuickStep).

1. Place the reference horn at the center of the DUT holder inside R&S ATS-TEMP. Direct the main antenna aperture upwards, toward the measurement antenna (in the boresight of the antennas).
2. Connect the [VNA](#) as follows:
 - Connect one port to the reference antenna fixed at the DUT holder.
 - Connect the second port (third port) to the vertically polarized test antenna (to the horizontally polarized test antenna) at the top of the elevation arm.
3. Place the first temperature sensor of the thermal test device into the OTA Bubble, near the DUT.
4. Place the second temperature sensor outside the OTA Bubble, near the base of the mast.
5. Set the following values on thermal test device:
 - Room temperature: 25 °C
 - Soak time: 5 minutes
 - Flow rate: 10 CF

6. Perform a S21 (and S31 for dual-port measurement antenna) measurement of amplitude over the desired frequency range after 1 or 2 minutes of the soak time.
7. Store the data into the `S21Temp25` file.
8. Set temperature points corresponding to the desired temperatures with 5 minutes soak times.
9. Repeat [step 6](#) for each temperature.
10. Store the data into the `S21TempX` file.
The difference between the two measurements is the amplitude calibration coefficient.

4 Performing Measurements

WARNING

Risk of burns caused by hot steam or hot surface

During extreme temperature testing, the surfaces of the OTA Bubble, mast, hoses, and the DUT can be very hot. You can suffer from burns if you touch these surfaces.

To prevent burns, allow the R&S ATS-TEMP to adjust to room temperature before touching.

When opening the R&S ATS-TEMP, hot steam can escape and scald you. To prevent injury, wait until the surface of the dome of R&S ATS-TEMP is at room temperature before opening. Use heat resistant gloves when touching any hot parts.

WARNING

Risk of frostbite caused by cold surface

During extreme temperature testing, the surfaces of the OTA Bubble, mast, and hoses can be very cold. You can suffer from frostbite if you touch these surfaces. Especially, be aware that your fingers can freeze to a surface at temperatures below 0° C.

To prevent frostbite, allow the R&S ATS-TEMP to adjust to room temperature before touching. Use cold resistant gloves when touching any cold parts.

In this chapter, measurements are segmented according to the type of DUT: passive or active. For simplicity, even if an [R&S OSP](#) switch and control unit is used, this manual assumes a direct connection to the measurement instruments.

- A **passive DUT** is defined as an RF-cable fed DUT where one/two ports are connected to a [VNA](#). The other two ports are connected to the measurement antenna at the end of the elevation arm inside R&S ATS1000. Due to the temperature dependency of the cable attenuation and phase on temperature, perform first the R&S ATS-TEMP and temperature calibrations.
- An **active DUT** is defined as a DUT with an internal RF transceiver that can generate and/or receive RF signals that can be continuous wave (CW) or modulated signals. An RF-cable is not part of this setup and only a R&S ATS-TEMP calibration is necessary before measurements.

The remaining measurement steps are the same for both passive and active DUTs.

For measurements, perform the following steps:

1. Place the [DUT](#) at the center of the DUT holder inside the R&S ATS-TEMP, so that the antenna aperture is in the center of the quiet zone (for far-field measurements).
2. Connect the measurement equipment:
 - Passive: [VNA](#), as described in [Chapter 3.4.2, "Temperature Calibration"](#), on page 23.

- Active: connect the signal analyzer (R&S FSW) and/or the signal generator (R&S SMW200A) directly to the antenna ports on the side of the chamber or via an [R&S OSP](#) on the instrument rack.
3. Place the first temperature sensor of thermal test device into the OTA Bubble near the location of the DUT.
 4. Place the second temperature sensor of thermal test device outside the OTA Bubble near the base of the mast.
 5. Check that thermal test device uses correct sensor for temperature adjustment of airstream from thermal test device.
 6. At the thermal test device, set temperature points corresponding to desired temperatures with minimum 3 minutes soak times.
 7. Perform an S21 (S31 for second port) measurement of amplitude and phase over desired frequency range after 1 to 2 minutes into the soak time for all desired temperature points.
 8. Repeat for all measurements needed.
 9. Switch off thermal test device.
 10. Check for external condensation on the outside of the OTA Bubble.
 11. To continue with next measurements, wait until the temperature inside the OTA Bubble reaches room temperature.

5 Troubleshooting

- **General remarks**

We recommend performing regular checkups of the system thermal properties using an external temperature sensor at non-extreme temperatures.

- **If the system is taking longer than usual to reach desired temperatures**

- Check the flow rate on thermal test device. We recommend a flow rate of 10 CF, maximum 12 CF.
- Check for any thermal leakage on the dome. If there are obvious signs of deterioration (cracks in the surface, brittle surface when touched), call a Rohde & Schwarz sales representative to replace the dome.
- Check for any thermal leakage at the hose / OTA Bubble / antenna test chamber interface. If there is a leakage, tighten the hose. Otherwise call Rohde & Schwarz service for repair.

- **If there are visible signs of thermal damage on the OTA Bubble**

Call Rohde & Schwarz sales for a dome replacement.

- **If there is condensation outside the OTA Bubble**

Condensation is expected in particularly hot and humid climates. We recommend operating R&S ATS-TEMP in a temperature and humidity-controlled lab.

If there is still condensation, use a cloth to absorb the water. Run then R&S ATS-TEMP through several hot-cold iterations (without DUT) to remove the humidity from the air before performing DUT measurements.

Glossary

A

ACLR: adjacent channel leakage ratio

C

CW: continuous wave

D

DUT: device under test

E

EVM: error vector magnitude

O

OTA: over the air

OTA Bubble: RF transparent, oval-shaped thermal chamber of the R&S ATS-TEMP

R

R&S AMS32: Rohde & Schwarz measurement software (part of R&S EMC32 software), refer to www.rohde-schwarz.com/product/emc32

R&S ATS1000: Rohde & Schwarz antenna test system, refer to www.rohde-schwarz.com/product/ats1000

R&S CONTEST: Rohde & Schwarz application software

R&S FSW: Rohde & Schwarz signal and spectrum analyzer, refer to www.rohde-schwarz.com/product/fsw

R&S OSP: Rohde & Schwarz open switch and control platform, refer to www.rohde-schwarz.com/product/osp

R&S QS-ATSCAL: Rohde & Schwarz automatic calibration of R&S ATS1000 and positioner driver (part of R&S QuickStep software), refer to www.rohde-schwarz.com/product/quickstep

R&S SMW200: Rohde & Schwarz vector signal generator, refer to www.rohde-schwarz.com/product/smw200

R&S ZVA: Rohde & Schwarz vector network analyzer, refer to www.rohde-schwarz.com/product/zva

RF: radio frequency

S

SEM: spectral emission mask

T

TA-5000A: temperature testing system ThermalAir 5000A, refer to [MPI Thermal](#)

V

VNA: vector network analyzer

Index

C

Calibration	11
Path loss	21
Temperature	23
Characteristics	8
Connecting to DUT	19
Cooling	16

D

Dome (removable)	6, 12
DUT	6, 19

H

Heating	17
---------------	----

L

Labels	7
Locking grip	12

M

Measurements	
Active DUT	25
Passive DUT	25

O

OTA Bubble	10
------------------	----

P

Path loss calibration	21
-----------------------------	----

R

Risks	
Burns	6
Explosion	7
Frostbite	6
Intoxication	7
Thermal air-stream device	7

S

Safety	5
Labels	7
Setup	15
Device cooling	16
Extreme temperatures	17
Specification	8

T

Temperature calibration	23
Thermal air-stream device	7, 17

U

Unpacking	10
-----------------	----