

R&S[®]SMBV-K360, R&S[®]SMBVB-K360, R&S[®]SMW-K360 ERA-GLONASS Test Suite User Manual



1178544302
Version 11

ROHDE & SCHWARZ
Make ideas real



This manual describes the following R&S®CMWrun option for software version V1.9.10 or higher:

- R&S®SMBV-K360 (ERA-GLONASS test suite)
- R&S®SMBVB-K360 (ERA-GLONASS test suite)
- R&S®SMW-K360 (ERA-GLONASS test suite)

© 2022 Rohde & Schwarz GmbH & Co. KG
Muehldorfstr. 15, 81671 Muenchen, Germany
Phone: +49 89 41 29 - 0

Email: info@rohde-schwarz.com

Internet: www.rohde-schwarz.com

Subject to change – data without tolerance limits is not binding.

R&S® is a registered trademark of Rohde & Schwarz GmbH & Co. KG.

Trade names are trademarks of the owners.

1178.5443.02 | Version 11 | R&S®SMBV-K360, R&S®SMBVB-K360, R&S®SMW-K360

The following abbreviations are used throughout this manual: Options R&S®SMBV-K360, R&S®SMBVB-K360, and R&S®SMW-K360 are abbreviated as R&S SMx-K360. R&S® is abbreviated as R&S. R&S®SMBV100A and R&S®SMBV100B are abbreviated as R&S SMBV.

Contents

1	Key features	5
2	Prerequisites	7
3	Test setup	9
4	System configuration	10
4.1	Preparation of controller PC.....	10
4.2	Preparation of instrument connection.....	10
4.3	Preparation of IVS connection.....	11
5	Test configuration	16
5.1	Connection setting.....	17
5.2	Vehicle simulation setting.....	17
5.3	GNSS simulation setting.....	19
5.4	Signal power setting.....	20
5.5	Test case setting.....	21
5.6	Advanced settings.....	26
6	Test results	30
7	Monitoring	35
8	Test module details	37

1 Key features

The test suites R&S SMx-K360 provide ERA-GLONASS tests with the sequencer tool R&S CMWrun. The tests are performed on a connected in-vehicle system (IVS) for ERA-GLONASS. The tests are as closely aligned with the selectable test specifications as possible. You can select the test specification GOST 33471 or GOST R 55534.

The test equipment simulates a global navigation satellite system (GNSS). The R&S CMWrun controls the test equipment via SCPI commands and the IVS typically via vendor-specific commands. The test cases can be performed fully automatic, without user interaction.

Table 1-1: Supported test cases

Test case	Test purpose
5.1 - Availability of position/velocity for GLONASS L1	Checks that the GNSS receiver can receive and process the navigation signal of standard precision in L1 band of GLONASS GNSS to determine vehicle coordinates and its velocity
5.2 - Availability of position/velocity for GPS L1	Checks that the GNSS receiver can receive and process the navigation signal of standard precision in L1 band of GPS GNSS to determine vehicle coordinates and its velocity
5.3 - Availability of position/velocity for combined GPS/GLONASS L1 processing	Checks that the GNSS receiver can receive and process the navigation signal of standard precision in L1 band of GLONASS and GPS GNSS to determine vehicle coordinates and its velocity
5.4 - Verify NMEA transmission from DUT	Checks that the GNSS receiver outputs the navigation parameter data to external devices in NMEA-0183 format
5.5 - Functional RAIM test	Checks the receiver autonomous integrity monitoring (RAIM) algorithm by degrading the pseudo range of several satellites over time in the simulated signal. The satellites are biased over time and detected satellites must be neglected after exceeding the specified threshold
5.6 - Use different reference systems (PZ-90/WGS-84)	Checks that the receiver can utilize PZ-90 and WGS-84 coordinate systems
5.7 - Location accuracy (static receiver)	Estimates the error in the evaluation of the plane view and altitude in the autonomous static mode. A static location is simulated and the error between actual and determined location is calculated
5.8 - Location accuracy (moving receiver)	Estimates the error in the evaluation of the plane view, altitude and velocity in the dynamic mode. A certain trajectory is simulated and the error between actual and determined location as well as the velocity error is calculated
5.9 - Minimum update rate of NMEA stream	Checks that received message time delta between adjacent sentences does not exceed the specified threshold
5.10 - Reacquisition time	Evaluates the restore time for signal tracking for a certain GNSS constellation after tracking was lost due to signal blockage. To simulate blockage, the radio frequency signal is switched off for a specified time and the recovery time is measured after the signal was switched on
5.11 - Time-to-first fix (TTFF) under cold start conditions	Determines the time to first navigation fix for a reset receiver. The ephemeris and almanac data from all satellites are cleared and thus, the receiver has to gain all data and the time to first fix is measured. The averaged measurement time must not exceed the specified threshold

Test case	Test purpose
5.12 - Tracking and acquisition sensitivity	Verifies the sensitivity of the GNSS navigation module in signal acquisition mode and in tracking mode. The minimum navigation acquisition power is determined by decreasing the signal power stepwise. Afterwards the minimum power is ascertained until the receiver loses signal tracking. Caution: For this test, a precise calibration of the signal path is necessary.
5.13 - Change update rate of NMEA stream	Checks the supported observation data update rate. All required NMEA-0183 sentences must be received with same data rate.
5.14 - Check cutoff angle settings for navigation satellites	Checks that the receiver excludes satellites from the position calculation if the satellite is below the set minimum elevation angle because low-elevated satellites degrade the position calculation
5.15 - Checking power-off time of navigation module	Evaluates the power-off time of the GNSS navigation receiver after the power is switched off. The difference between actual and set switch-off time is verified

2 Prerequisites

Required equipment for **R&S SMBV-K360**:

- R&S SMBV100A for GNSS simulation must be equipped with the following options:
Hardware:
 - HW option R&S SMBV-B10
 - HW option R&S SMBV-B103/-B106Minimum required options:
 - R&S SMBV-K44, GPS
 - R&S SMBV-K91, extension to 12 satellites
 - R&S SMBV-K92, GNSS enhanced (motion files, atmospheric effects)
 - R&S SMBV-K94, GLONASS
 - R&S SMBV-K96, extension to 24 satellitesAdditional options for full test coverage:
 - R&S SMBV-K110, SBAS for functional RAIM test (5.5)
 - R&S SMBV-K102, antenna pattern and R&S SMBV-K103, spinning and attitude simulation for test location accuracy with moving receiver - test mode poor reception (test cases 5.8 and 5.9)
- R&S CMWrun base software, version 1.8.8 or higher.
No smart card and no licenses are required for R&S CMWrun.

Required equipment for **R&S SMBVB-K360**:

- R&S SMBV100B for GNSS simulation must be equipped with the following options:
Hardware:
 - HW option R&S SMBVB-B103Minimum required options:
 - R&S SMBVB-K520 real-time extension
 - R&S SMBVB-K44, GPS
 - R&S SMBVB-K94, GLONASSAdditional option for full test coverage:
 - R&S SMBVB-K108, antenna pattern, spinning and attitude simulation for test location accuracy with moving receiver - test mode poor reception (test cases 5.8 and 5.9)
- R&S CMWrun base software, version 1.9.6 or higher.
No smart card and no licenses are required for R&S CMWrun.

Required equipment for **R&S SMW-K360**:

- R&S SMW200A for GNSS simulation must be equipped with the following options:
Hardware:
 - HW option R&S SMW-B10
 - HW option R&S SMW-B103/-B203

Minimum required options:

- R&S SMW-K44, GPS
- R&S SMW-K94, GLONASS

Additional option for full test coverage:

- R&S SMW-K108, antenna pattern, spinning and attitude simulation for test location accuracy with moving receiver - test mode poor reception (test cases 5.8 and 5.9)
- R&S CMWrun base software, version 1.9.5 or higher.
No smart card and no licenses are required for R&S CMWrun.

3 Test setup

The following figure provides an overview of the test setup. In this example, the instrument an R&S SMBV100A is used. The test setup with another supported instrument is similar.

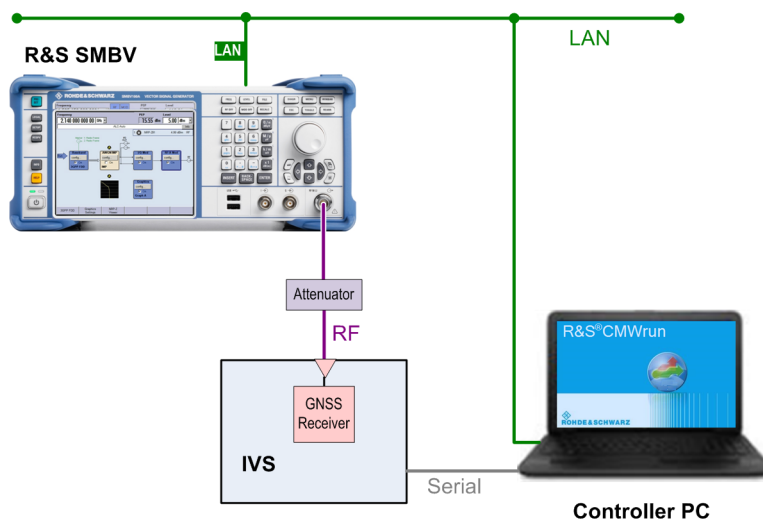

The test setup comprises the following components:

- An instrument, providing GNSS signals to the IVS for positioning. Connect the RF output port of the instrument to the RF port of the IVS (GNSS receiver).
- A computer executing the R&S CMWrun. The computer controls the instrument via SCPI connections (typically LAN). It controls the IVS typically via vendor-specific commands on a serial port interface.
- External attenuator is recommended for levels below -120 dBm, refer to "[External Power Attenuation](#)" on page 21.

4 System configuration

This chapter describes everything you have to do before using the system for the first time. Skip this chapter if you already have an operable system.

- [Preparation of controller PC](#)..... 10
- [Preparation of instrument connection](#)..... 10
- [Preparation of IVS connection](#)..... 11

4.1 Preparation of controller PC

To set up the controller PC, install the base software of R&S CMWrun. No smart card and no licenses are required for the R&S CMWrun with the R&S SMx-K360 ERA-GLO-NASS test suite.

Refer to the sequencer user manual, section Installation.



Ignore the message indicating no license is found.

4.2 Preparation of instrument connection

1. For remote control of the instrument, configure the resource settings "Resources" menu > "SCPI Connections". Configure the SCPI resource settings compatible to the test instrument. For the control of R&S SMBV, the entry with an alias "SMBV" is used. For the control of R&S SMW200A, the entry with an alias "SMW" is used. Refer to the sequencer user manual, section Resources > SCPI Connections.
2. For standard view of the measurement report, in the configuration dialog of measurement report, tab "Fail Options", deselect "Treat "Ignored" as "Failed""

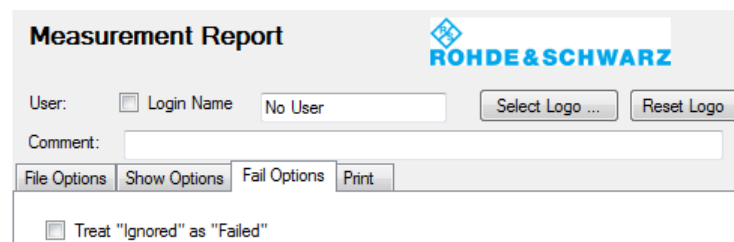

To access the measurement report configuration dialog, proceed as follows:

- a) To configure measurement report globally for all the tests, select "Resources" menu > "Measurement Report..."

- b) For only test plan-specific measurement report settings, double-click your test plan in the "File Browsers" on the left, the tab "Test Plans". On the test plan toolbar, select "Resources" menu > "Measurement Report...", use the button "Create Specific Settings".

Thus, the test plan contains the settings of test plan specific resources.

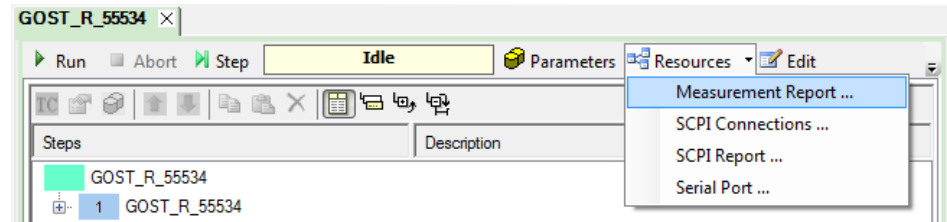

4.3 Preparation of IVS connection

1. For the remote control of an IVS, configure the resource settings "Resources" menu > "Serial Port". Configure the serial port resource settings compatible to your IVS.
Refer to the sequencer user manual, section Resources > Serial Port.

2. The following steps configure DUT attributes and properties.

Create your test plan:

- a) In the tab "Test Plans", specify a directory where you store your test plans.

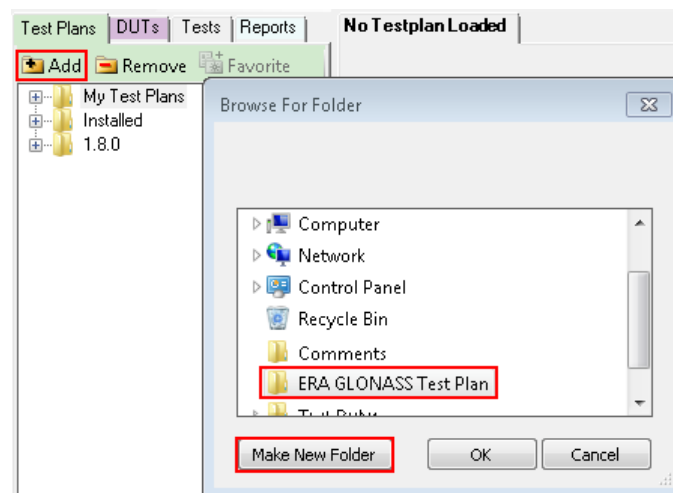

- b) Open configuration dialog via "File" > "New Testplan...".

- c) In the tab "Tests", select the installed ERA-GLONASS test plan.

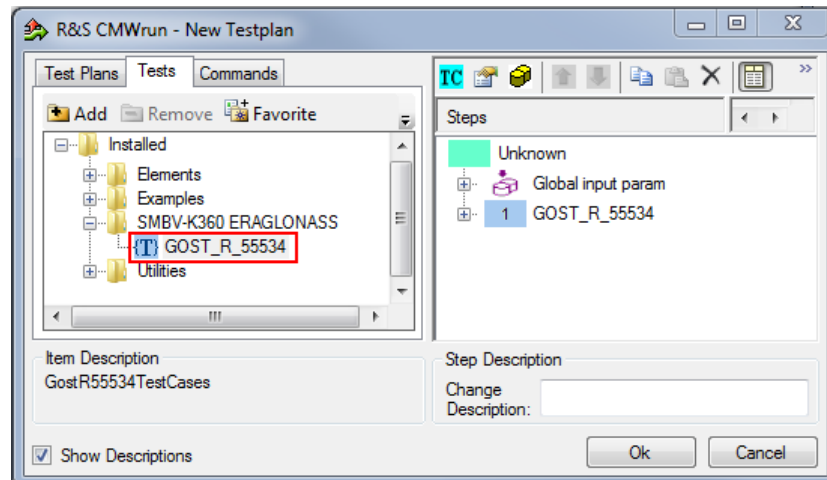

- d) Press "OK".

3. **Save your test plan** in the directory created in [step 2](#).

4. **Prepare your DUT's file:**

- a) In the tab "DUTs", you find several pre-defined DUT's configurations. To create your own, double-click `IVSTemplate.xml` to open configuration dialog "Edit DUT Properties".

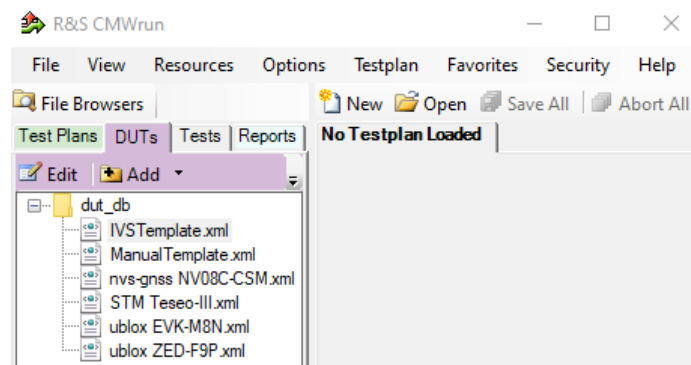

- b) Modify "Manufacturer" entry to assign DUTs name. Otherwise, you overwrite the pre-defined template.

- c) In the tab "Automation", configure the DUT-related automation methods, that are used for DUTs commands.
See also section DUT Files and Automation of the R&S CMWrun base manual.

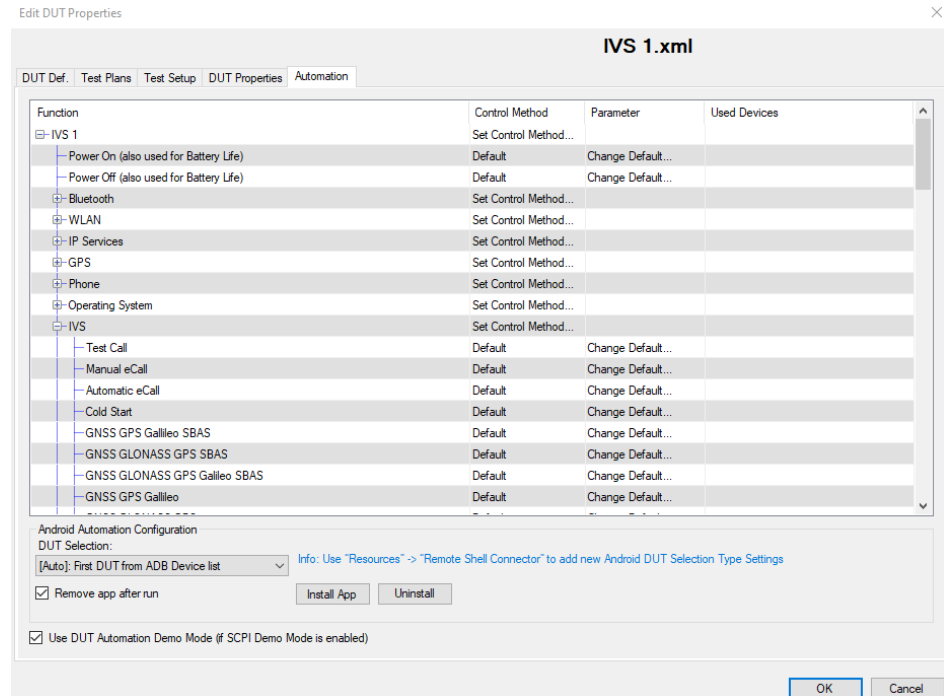

The test module supports the AT commands via COM ports and ADB commands. You can also mix control methods, e.g., ADB shell command sending with COM port NMEA reading. The default port is specified via "Resources" > "Serial Port".

Set all commands for which parameters are available. Furthermore, it is important to set the control method for the "IVS" -> "Read Back" function to read the NMEA stream properly.

For AT commands, map the serial ports accordingly to bi-directional or two-way usage.

- Bidirectional: uses common serial port for IVS configuration and the transmission of NMEA messages.
- Two-way: configures two serial ports to separate control connection and the connection for NMEA data.

- d) Each DUT command is connected to a new row in the corresponding dialogue. A waiting time after the execution can be set for each single command. Set also not needed commands to "not in use" to avoid automated stops for manual input. ASCII or hexadecimal notations are supported.

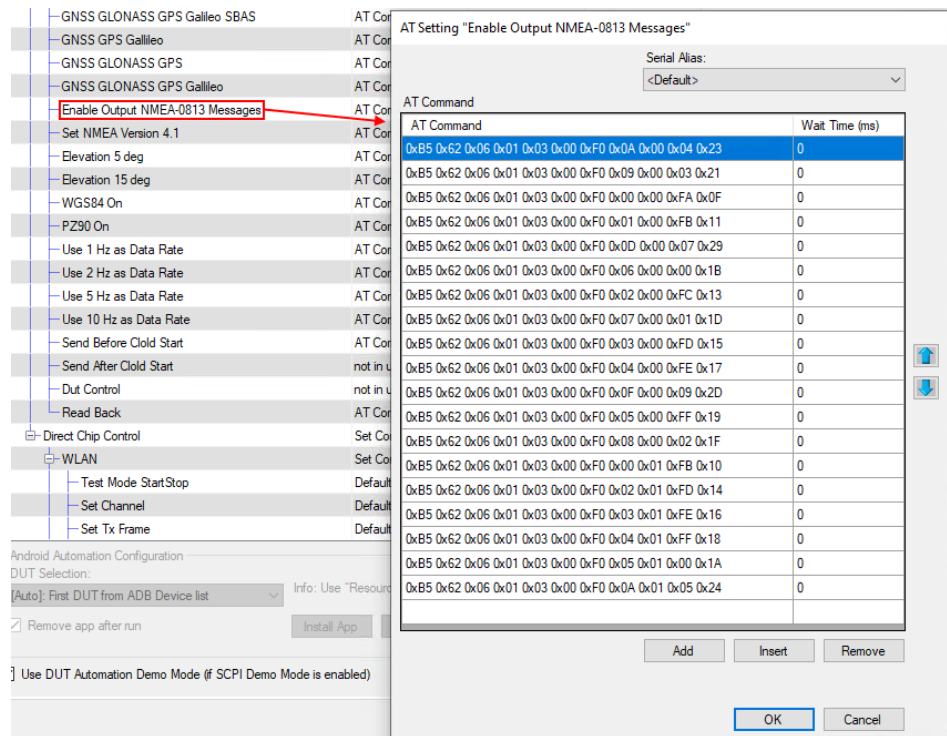

- e) Set all needed commands to control method "default"
 f) Set all not needed commands to control method "not in use"
 During test case execution, only command requests for all "default" commands show up

5. Assign a test plan to a DUT:

In the tab "Test Plans", select your test plan created in [step 2](#). Select "Add" and "OK".

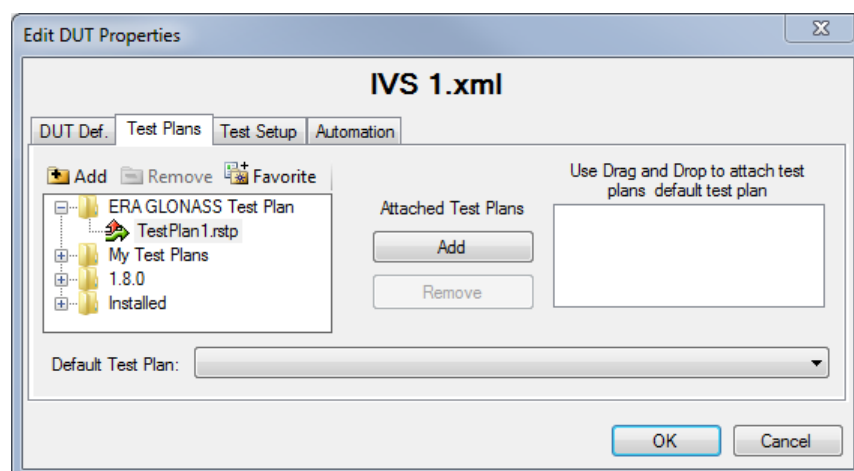

Your test plan is now assigned to your DUT.

6. Always start your tests from the tab "DUTs" by double-clicking a test plan assigned to your DUT. It guarantees, that the test plan executes the vendor-specific commands of your DUT. Otherwise, the test plan is aborted and with the error, "DUT type not found".

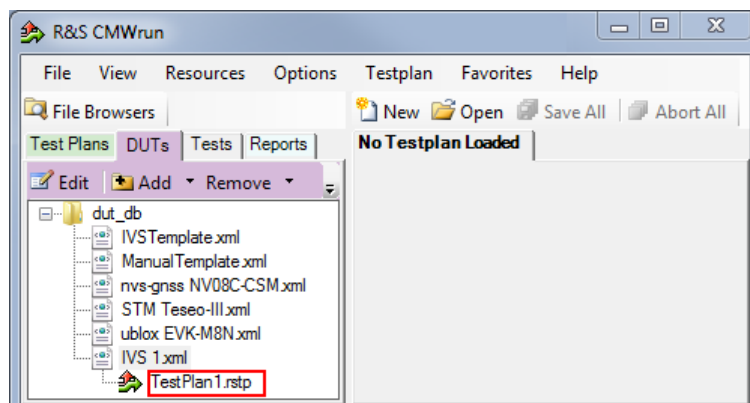

5 Test configuration

The property dialog box leads you to individual test configuration dialogs.

You can open the property dialog box from the "Testplan Details" subtab. Double-click the node, for example [1](#). Or select the node and click  "Properties ...".

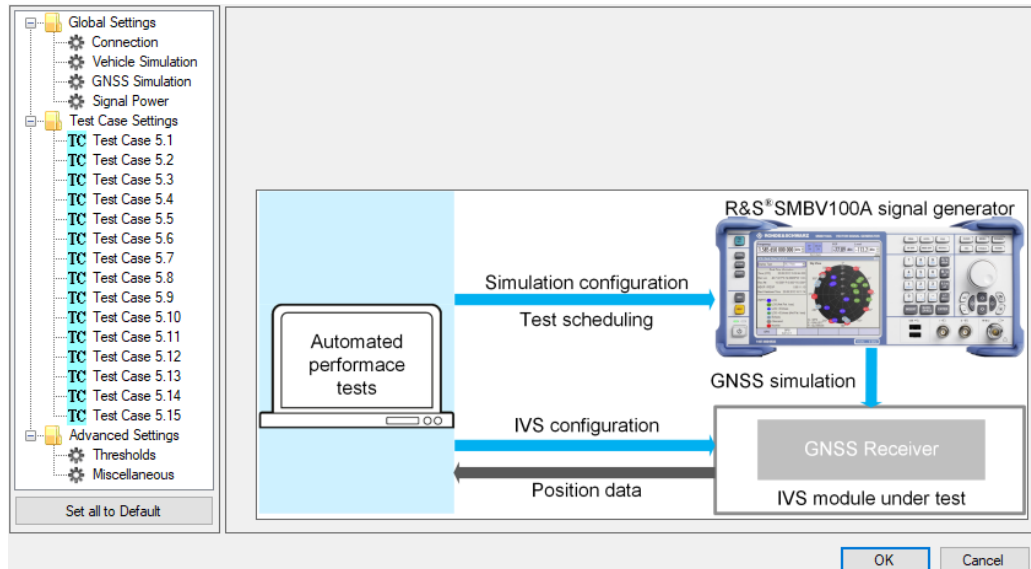

The property dialog box lists global settings, test case-specific settings for all supported ERA-GLONASS test cases from GOST 33471 or GOST R 55534 and advanced settings for non-conformance settings.

"Set all to Default" resets all settings: global settings, the settings of all test cases and advanced settings.



Changing the default settings results in deviation from the recommendations of GOST 33471. Any change in parameter values is indicated in the measurement report. The parameter values according to the test specification are always shown in SCPI reports.

Use the navigation tree on the left, to open the corresponding configuration dialog. For description, refer to the following sections.

- [Connection setting](#)..... 17
- [Vehicle simulation setting](#)..... 17
- [GNSS simulation setting](#)..... 19
- [Signal power setting](#).....20
- [Test case setting](#)..... 21
- [Advanced settings](#).....26

5.1 Connection setting

Specifies the data rate for NMEA stream transmitted by the GNSS generator.

Set to Default

Resets all settings in the dialog.

5.2 Vehicle simulation setting

Specifies the geo-position of the IVS and simulates its movement.

Simulation Start Date/Time.....	18
Fixed Vehicle Location.....	18
Files for Movement and Visibility.....	18
Set to Default.....	19

Simulation Start Date/Time

Specifies the time signaled within the generated positioning data. You can use the time zone 0 (UTC - Greenwich) or UTC+3 (Moscow).

Fixed Vehicle Location

Specifies the IVS location for the tests on stationary vehicles. Select predefined location or specify geographical position manually. You can use coordinate system WGS84 or PZ90.

Files for Movement and Visibility

Selects files with predefined movement geo-coordinates. The files are used by the test case 5.1, 5.2, 5.3, and 5.8, see "[Test Case 5.8](#)" on page 23.

The following files complying standard are provided in the installation package:

- `GOSTC2_C3.xtd` for full reception, starting in Moscow, elliptical trajectory with changing velocity
The file is suitable for "Maximum Velocity/ Manoeuvring" test.

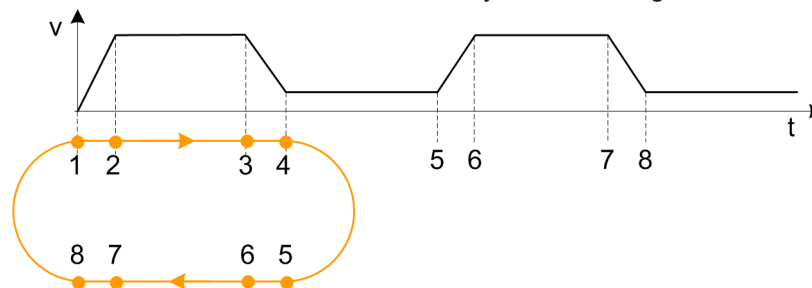

- `GOSTC4.xtd` for reception with periodical signal losses, starting in Moscow, movement in a circle
The file is suitable for "Blockage/ Poor Reception" test.

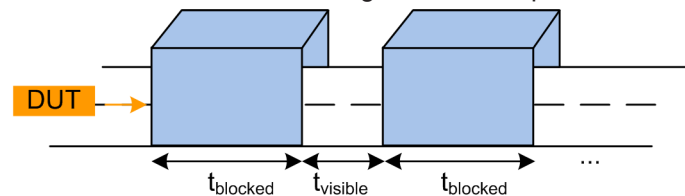

- `GOSTpoor_reception.ant_pat` for poor reception, e.g., between two buildings, with the following antenna pattern:
The file is suitable for "Poor Reception" test.

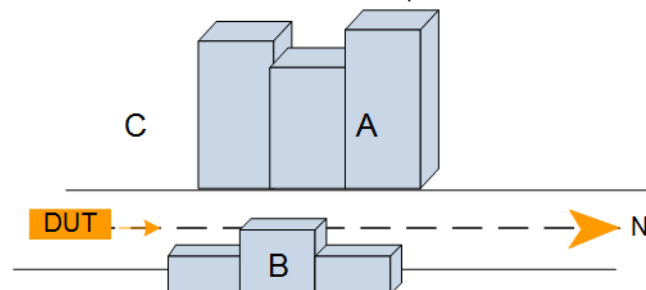

Table 5-1: Predefined visibility mask

Zone	Elevation	Azimuth	Description
A	0° to 60°	-150° to -30°	Bigger shield to the west
B	0° to 50°	70° to 130°	Smaller shield to the east
C	remaining	remaining	Open sky

Set to Default

Resets all settings in the dialog including pre-defined files.

5.3 GNSS simulation setting

Defines almanac and RINEX files and configures atmospheric models.

Type Approval.....	19
Almanac Files.....	20
Rinex Files.....	20
Troposphere.....	20
Ionosphere.....	20
Set to Default.....	20

Type Approval

Selects the test specification according to are the tests executed. You can select GOST 33471 or GOST R 55534.

Almanac Files

Specifies the path of almanac files containing orbit data and resources on active GNSS satellites.

Current GNSS almanac data can be downloaded from Internet via:

- <http://www.celestrak.com/GPS/almanac/>
The naming convention of the almanac file is: `almanac.sem/yuma.weekXXXX.YYYYYY.txt`,
Where `XXXX` denotes the GPS week and `YYYYYY` the time of almanac (TOA)
- <ftp://ftp.glonass-iac.ru/MCC/ALMANAC/>
The file extension of the GLONASS almanac file is: `xxx.agl`

Refer to the user manual of the instrument.

Rinex Files

Specifies the path of RINEX files.

The RINEX file format consists of three ASCII file types: observation data file, navigation message file and meteorological data file. The navigation RINEX files comprise the ephemeris information of all visible satellites at a control station or a commercial receiver.

RINEX navigation files can be downloaded from http://cddis.gsfc.nasa.gov/gnss_data-sum.html#brdc.

Refer to the user manual of R&S SMBV or R&S SMW200A, annex B.

Troposphere

Selects the tropospheric model to be simulated. The current version supports "Stanag" described in the NATO standard agreement 4294, issue 1.

Ionosphere

Selects the ionospheric model to be simulated.

- **Klobuchar**: default correction model used by GPS. It can be also used for delay estimations for any GNSS signal.
- **NeQuick**: 3D time-dependent ionospheric electron density model. It provides electron density in the ionosphere as a function of the position, time and the solar activity. For an R&S SMBV, option R&S SMBV-K110 for differential GPS is required.

Set to Default

Resets all settings in the dialog including pre-defined files.

5.4 Signal power setting

Configures the RF power of GNSS signal.

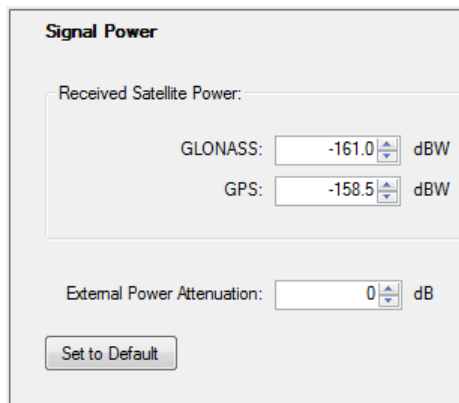

The image shows a dialog box titled "Signal Power". It contains three input fields with up and down arrows: "Received Satellite Power" (GLONASS: -161.0 dBW, GPS: -158.5 dBW) and "External Power Attenuation: 0 dB". A "Set to Default" button is located at the bottom left.

Received Satellite Power

Specifies the power of one GLONASS or GPS satellite.

External Power Attenuation

Specifies external power attenuation.

External attenuator is recommended for levels below -120 dBm for the following reasons:

- The level uncertainty increases for lower levels
- The maximum attenuation of the internal step attenuator is -150 dBW. Lower levels are achieved by reducing the internal amplification. The signal level goes down, but the noise floor remains at a constant level. Applying an external attenuator instead decreases the signal level and the noise floor to the same degree, thus maintaining the dynamic range.
- The minimum of the level setting range is -200 dBW. Attenuators are the only way to reach even lower levels

Refer to [Chapter 3, "Test setup"](#), on page 9.

Set to Default

Resets all settings in the dialog.

5.5 Test case setting

The dialog box lists all supported ERA-GLONASS test cases from GOST 33471 or GOST R 55534 (selectable).

Click an individual test case to the left, to open the corresponding configuration dialog. Most of the signal settings are by default according to the test specification.

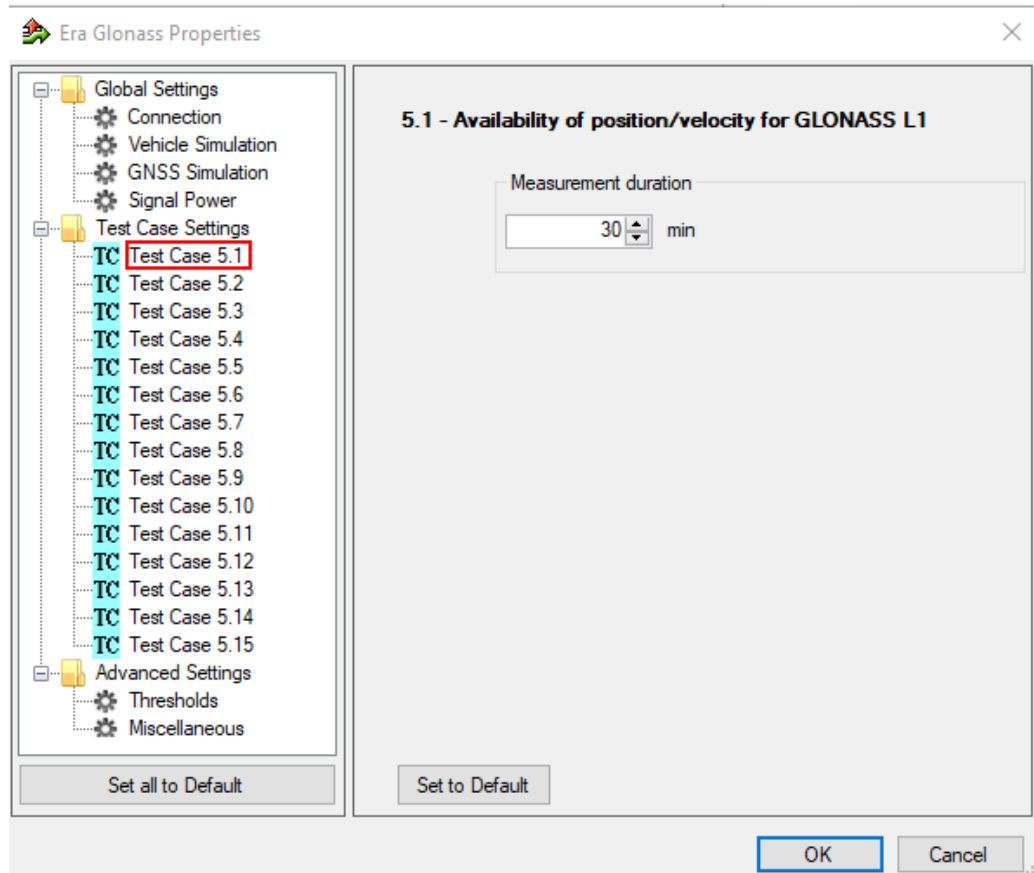

Several test cases contain self-explanatory settings as "Measurement Duration", "Total Test Duration...", or "Set to Default".

The total test duration per system specifies the total time for each subtest enabled in this test module per GNSS standard including waiting time (e.g. for acquisition).

The following description covers only remaining settings.

Test Case 5.5.....	23
Test Case 5.7.....	23
Test Case 5.8.....	23
Test Case 5.10.....	24
Test Case 5.11.....	25
Test Case 5.13.....	26
Test Case 5.14.....	26

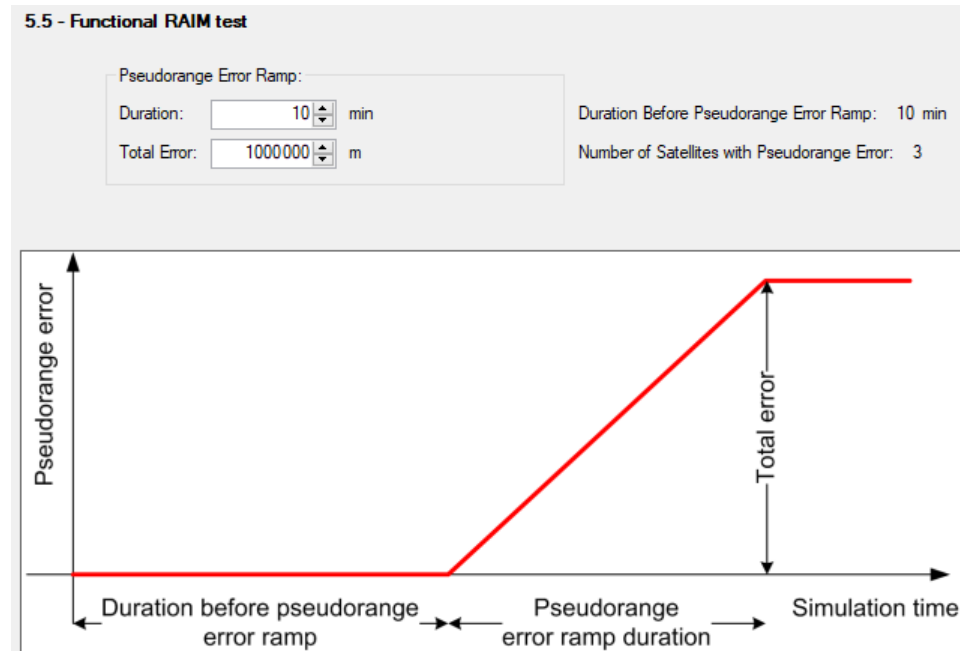
Test Case 5.5

GUI configures the following parameters:

- "Pseudorange Error Ramp": Within the specified "Duration", the fault in positioning data linearly increases from 0 to the specified "Total Error".
- "Duration Before Pseudorange Error Ramp": At the beginning, the instrument transmits GNSS signals of all satellites with correct positioning data for specified time.
- "Number of Satellites with Pseudorange Error": After the defined time period, the defined number of satellites transmits incorrect positioning data.

Test Case 5.7

GUI enables the standards to be tested: GLONASS, GPS or both standards and measurement durations per enabled GNSS standard.

Test Case 5.8

The configuration dialog enables and configures the "Maximum Velocity/ Manoeuvring" and "Blockage/ Poor Reception" tests of location accuracy.

5.8 - Location accuracy (moving receiver)

Measurement duration per system

Maximum Velocity/Manoeuvring	Blockage/Poor Reception
60 min	60 min

Almanac Collection ?

Time interval: 0 s

Total test duration per system and mode ?

Full Reception	Blockage/Poor Reception
65 min 00 sec	65 min 00 sec

System

	GLONASS/GPS	GLONASS	GPS
Maximum Velocity/Manoeuvring	<input checked="" type="checkbox"/>	<input checked="" type="checkbox"/>	<input checked="" type="checkbox"/>
Blockage/Poor Reception	<input checked="" type="checkbox"/>	<input checked="" type="checkbox"/>	<input checked="" type="checkbox"/>

Movement and antenna pattern files

GOSTC2_C3.xtd

GOSTC4.xtd

GUI enables the standards (GLONASS, GPS or both) and subtests to be tested including the test duration.

Measurement duration per system Sets the measurement time per enabled GNSS standard.

Almanac Collection Specifies the waiting time for the data collection by the IVS before starting the measurement

Total test duration per system and mode Specifies the total time for each subtest enabled in this test module per GNSS standard including waiting time.

System Enables the subtests to be executed and GNSS standard for testing. The subtests are per default configured via the following configuration files:

- "Maximum Velocity/ Manoeuvring": full reception test pre-configured via GOSTC2_C3.xtd.
- "Blockage/ Poor Reception": test pre-configured via GOSTC4.xtd

Movement and antenna pattern file The displayed files contain signal characteristics for particular subtests, refer to "[Files for Movement and Visibility](#)" on page 18.

Test Case 5.10

GUI configures the number of measurements per GNSS standard (GLONASS, GPS or both). One measurement comprises signal on, signal off, signal on, until the DUT can acquire the signal again.

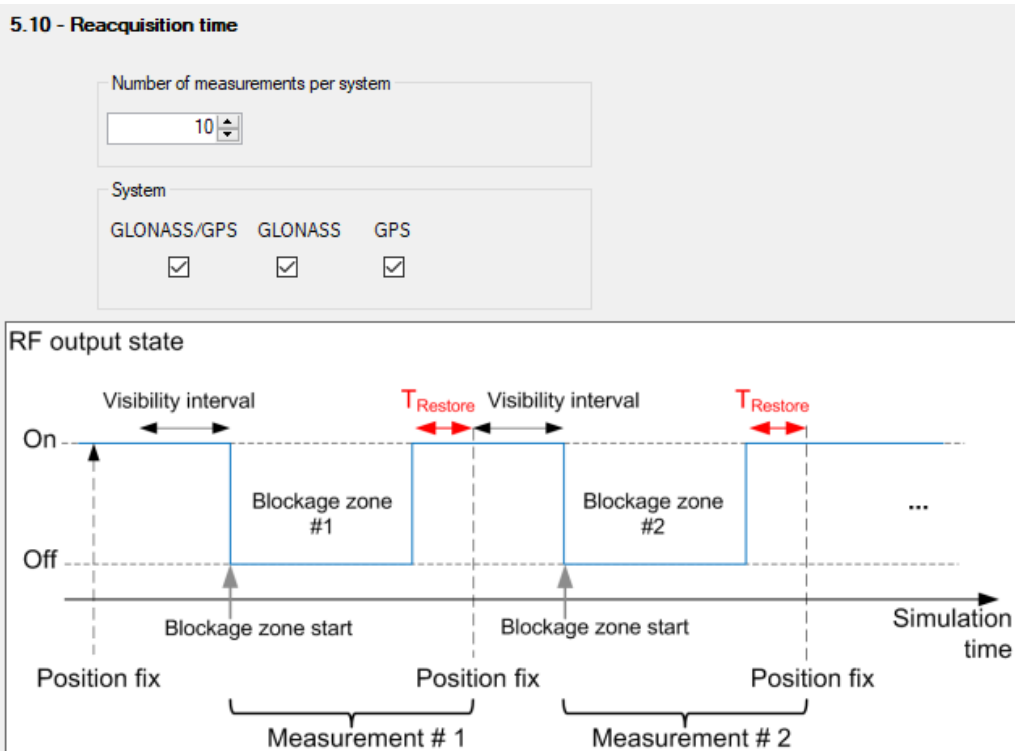
**Test Case 5.11**

GUI configures the number of measurements per standard (GLONASS, GPS or both). One measurement comprises specified visibility interval and cold start of the DUT, until it can acquire the signal again.

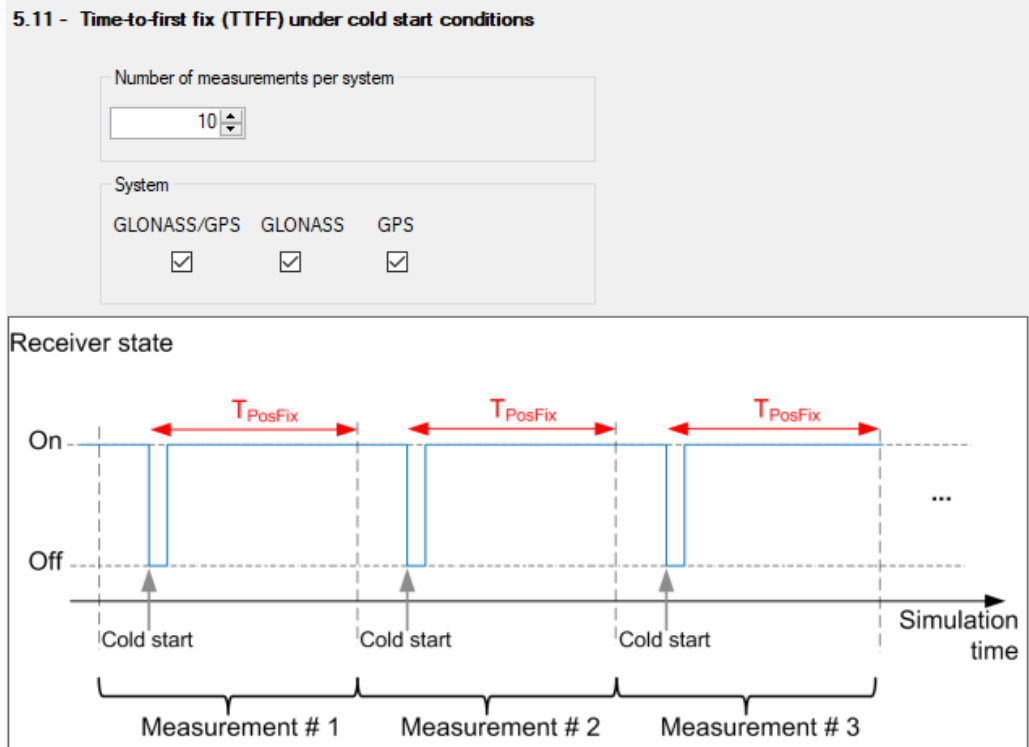
**Test Case 5.13**

GUI enables various data rates and sets the measurement duration per data rate.

Test Case 5.14

GUI enables the elevation cut-off angle to be tested.

5.6 Advanced settings

The following section specifies the settings to speed up the tests or to loosen the strict conformance limits and conditions. Note, that all default settings are according to the specification. For tests according to the specification, keep the advanced settings unchanged.

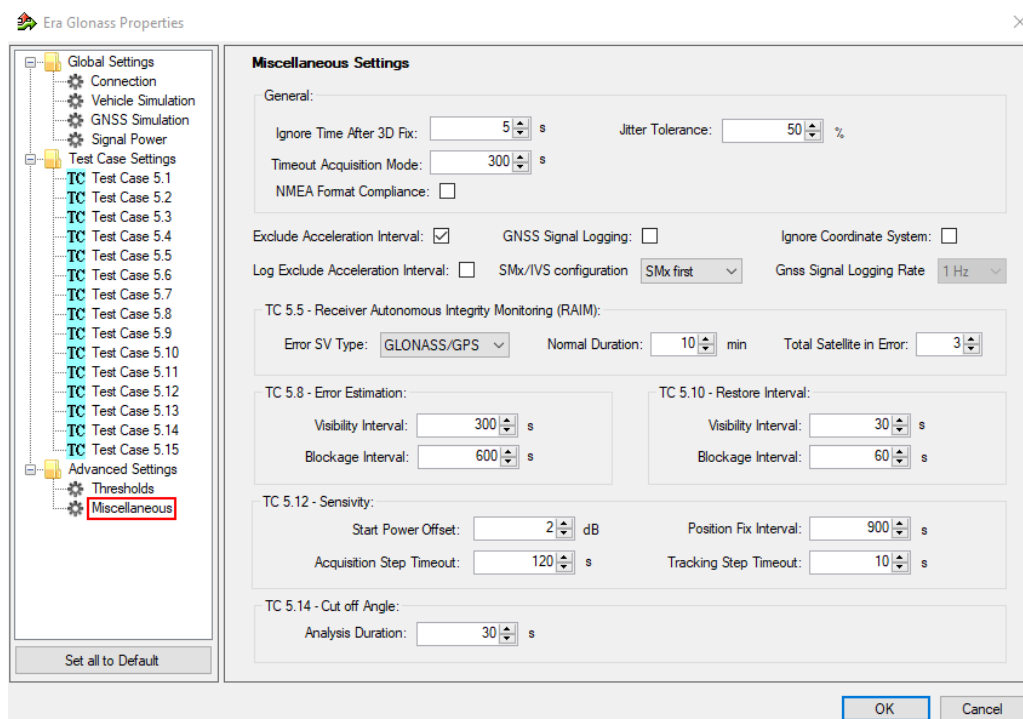

The following parameters are configurable.

Thresholds.....	27
Miscellaneous.....	27
L General.....	27
L Exclude Acceleration Interval.....	28
L GNSS Signal Logging.....	28
L Ignore Coordinate System.....	28
L Log Exclude Acceleration Interval.....	28
L SMx/IVS configuration.....	28
L GNSS Signal Logging Rate.....	29
L TC 5.5 Receiver Autonomous integrity Monitoring (RAIM).....	29
L TC 5.8 Error Estimation / TC 5.10 Restore Interval.....	29
L TC 5.12 Sensitivity.....	29
L TC 5.14 Cut off Angle.....	29

Thresholds

Specifies and enables different test limit values, than defined in standard. These settings change the criteria of pass/fail verdict, therefore they are password protected.

Miscellaneous

Specifies the settings for non-conformance tests.

General ← Miscellaneous

- **Ignore time after 3D fix:** the coordinates calculated by receivers are ignored in the test case for some time after the first 3D fix is attained. Some receivers make a fix far away the true location and converge to that point after couple of seconds. This

setting can bias the error statistics and can be increased for more stability of the results.

- **Jitter tolerance:** maximal jitter allowed for the transmission of NMEA block related to the NMEA rate
- **Timeout acquisition mode:** maximum time duration after that the IVS has to acquire satellite signals
- **Timeout tracking mode:** maximum time duration where the 3D fix is allowed to be lost
- **NMEA format compliance:** if enabled, the strict format compliance of the DUTs messages with NMEA standard is required to pass the test

Exclude Acceleration Interval ← Miscellaneous

If enabled, excludes trajectory intervals 1-2, 3-4, 5-6, and 7-8. The parameter is relevant for TC 5.8 and TC 5.13, measurements are not considered for error calculation.

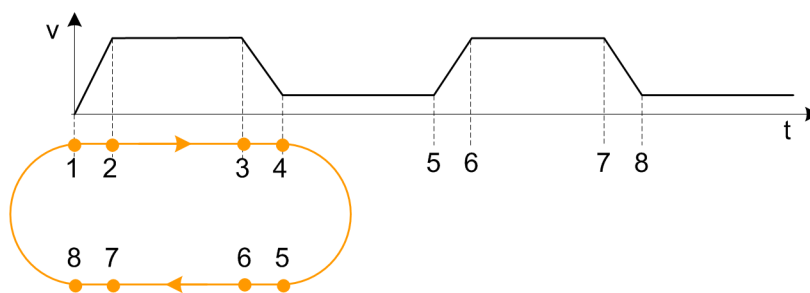

GNSS Signal Logging ← Miscellaneous

If enabled, the results with NMEA sentence are stored in log file in the instrument directory `/hdd/Gnss_Gen/Log`. The following naming conventions for the result files are applied:

```
<Test case>-<DUT>-<navigation system>-<coordinate system [-extension]>-
<date><time>.log
```

- Test case: TC51, TC52...
- DUT: The name of device under test
- Navigation system: GL (for GLONASS), GP (for GPS), GN (for GNSS)
- Coordinate system: W (for WGS84), P (for PZ90)
- Extension: F (for full reception), P (for pure reception), B (for blockage mode)
- Date: yyyy-mm-dd
- Time: hh-mm-ss

Ignore Coordinate System ← Miscellaneous

if enabled, all test cases can be executed even when IVS supports only one coordinate system.

Log Exclude Acceleration Interval ← Miscellaneous

If enabled, the exclusion is logged.

SMx/IVS configuration ← Miscellaneous

- "Parallel": the configurations of the instrument and IVS are started in parallel
- "SMx first": the instrument is configured first, afterwards the IVS is configured

GNSS Signal Logging Rate ← Miscellaneous

Sets the rate for GNSS signal logging at R&S CMWrun.

TC 5.5 Receiver Autonomous integrity Monitoring (RAIM) ← Miscellaneous

- **Error SV type:** GLONASS/GPS, GLONASS, or GPS
- **Normal duration:** Duration before pseudorange error ramp
- **Total satellite in error:** Number of satellites with erroneous pseudorange

TC 5.8 Error Estimation / TC 5.10 Restore Interval ← Miscellaneous

Specifies visibility and blockage intervals for TC 5.8 and TC 5.10.

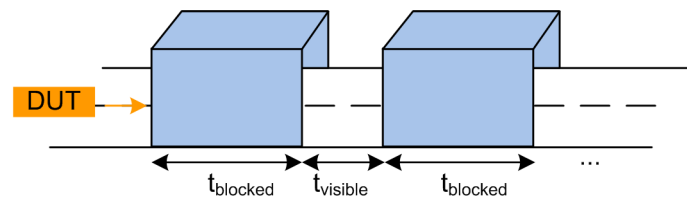
**TC 5.12 Sensitivity** ← Miscellaneous

Antenna input power [dBW]

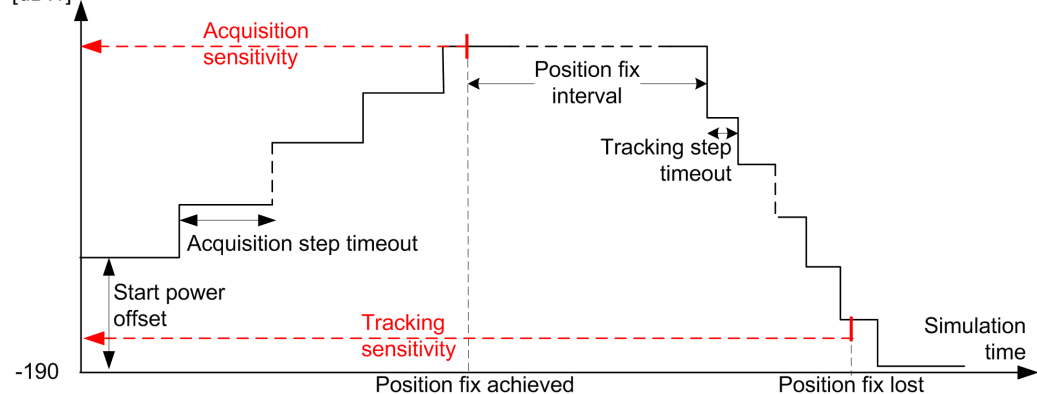

- **Start power offset:** Offset from the initial power in the acquisition phase. Add an offset if you know that your DUT acquisition sensitivity level is above the initial power value of -190 dBW. This parameter shortens test time significantly.
- **Position fix interval:** Time duration with fixed position to wait before decreasing the level of satellite signals
- **Acquisition step timeout:** Wait duration for the position fix at a certain power level before increasing the level again. The acquisition sensitivity is measured at increasing power steps and is stopped if IVS reports signal acquisition or the maximum output power of instrument is reached.
- **Tracking step timeout:** Wait duration for the position fix lost at a certain power level before decreasing the level again. The tracking sensitivity is measured at decreasing power steps and is stopped when IVS reports position loss.

TC 5.14 Cut off Angle ← Miscellaneous

Specifies analysis duration for TC 5.14.

6 Test results

The measurement report contains a result table for each executed test case. The tables list the test items and conditions, the performed test steps, their results and pass/fail verdicts. In addition, the measurement report indicates all the parameters set to non-default values.

The test cases 5.1 to 5.3 are similar. They are performed for different GNSS standard settings.

GOST_R_55534: 5.1 - Availability of position/velocity for GLONASS L1

Test Items and Conditions	DUT	Result	Unit	Status
Plane peak error <i>GLONASS</i>	ublox EVK-M8N	7.03	m	
Height peak error <i>GLONASS</i>	ublox EVK-M8N	9.72	m	
Velocity peak error <i>GLONASS</i>	ublox EVK-M8N	5.69	m/s	
Test result				Passed

GOST_R_55534: 5.4 - Verify NMEA transmission from DUT

Test Items and Conditions	DUT	Threshold	Result	Unit	Status
NMEA-0183 Sentence rate <i>GLONASS/GPS</i>	ublox EVK-M8N	500	123	ms	
NMEA-0183 Format: GGA <i>GLONASS/GPS</i>	ublox EVK-M8N		OK		
NMEA-0183 Format: GSA <i>GLONASS/GPS</i>	ublox EVK-M8N		OK		
NMEA-0183 Format: GSV <i>GLONASS/GPS</i>	ublox EVK-M8N		OK		
NMEA-0183 Format: RMC <i>GLONASS/GPS</i>	ublox EVK-M8N		OK		
NMEA-0183 Format: VTG <i>GLONASS/GPS</i>	ublox EVK-M8N		OK		
Test result					Passed

GOST_R_55534: 5.5 - Functional RAIM test

Test Items and Conditions	DUT	Result	Elapsed Time	Unit	Status
Satellite removed from Navigation solution: PRN 8	ublox EVK-M8N	YES	20.28	min	
Satellite removed from Navigation solution: PRN 40	ublox EVK-M8N	YES	20.3	min	
Satellite removed from Navigation solution: PRN 41	ublox EVK-M8N	YES	20.3	min	
Test result					Passed

GOST_R_55534: 5.6 - Use of different reference systems (PZ-90/WGS-84)

<i>Test Items and Conditions</i>	<i>DUT</i>	<i>Threshold</i>	<i>Result</i>	<i>Unit</i>	<i>Status</i>
Plane Transformation error <i>GLONASS</i>	ublox EVK-M8N	15	1.26	m	
Height Transformation error <i>GLONASS</i>	ublox EVK-M8N	20	3.47	m	
Test result					Passed

GOST_R_55534: 5.7 - Location accuracy (static receiver)

<i>Test Items and Conditions</i>	<i>DUT</i>	<i>Threshold</i>	<i>Result</i>	<i>Unit</i>	<i>Status</i>
Plane error <i>GLONASS</i>	ublox EVK-M8N	15	3.07	m	
Height error <i>GLONASS</i>	ublox EVK-M8N	20	3.49	m	
Plane error <i>GPS</i>	ublox EVK-M8N	15	1.34	m	
Height error <i>GPS</i>	ublox EVK-M8N	20	1.26	m	
Plane error <i>GLONASS/GPS</i>	ublox EVK-M8N	15	2.77	m	
Height error <i>GLONASS/GPS</i>	ublox EVK-M8N	20	2.45	m	
Average plane error	ublox EVK-M8N	15	2.39	m	
Average height error	ublox EVK-M8N	20	2.4	m	
Test result					Passed

GOST_R_55534: 5.8 - Location accuracy (moving receiver)

Test Items and Conditions	DUT	Threshold	Result	Unit	Status
- Full Reception Mode					
Plane error <i>GLONASS</i>	ublox EVK-M8N	15	3.16	m	
Height error <i>GLONASS</i>	ublox EVK-M8N	20	3.31	m	
Velocity error <i>GLONASS</i>	ublox EVK-M8N	0.1	0.02	m/s	
Plane error <i>GPS</i>	ublox EVK-M8N	15	1.28	m	
Height error <i>GPS</i>	ublox EVK-M8N	20	1.33	m	
Velocity error <i>GPS</i>	ublox EVK-M8N	0.1	0.01	m/s	
Plane error <i>GLONASS/GPS</i>	ublox EVK-M8N	15	2.74	m	
Height error <i>GLONASS/GPS</i>	ublox EVK-M8N	20	2.57	m	
Velocity error <i>GLONASS/GPS</i>	ublox EVK-M8N	0.1	0.01	m/s	
Average plane error		15	2.39	m	
Average height error		20	2.4	m	
Average velocity error		0.1	0.01	m/s	
- Blockage Mode					
Plane error <i>GLONASS</i>	ublox EVK-M8N	15	3.19	m	
Height error <i>GLONASS</i>	ublox EVK-M8N	20	3.61	m	
Velocity error <i>GLONASS</i>	ublox EVK-M8N	0.1	0.03	m/s	
Plane error <i>GPS</i>	ublox EVK-M8N	15	1.23	m	
Height error <i>GPS</i>	ublox EVK-M8N	20	1.17	m	
Velocity error <i>GPS</i>	ublox EVK-M8N	0.1	0.01	m/s	
Plane error <i>GLONASS/GPS</i>	ublox EVK-M8N	15	2.34	m	
Height error <i>GLONASS/GPS</i>	ublox EVK-M8N	20	2.56	m	
Velocity error <i>GLONASS/GPS</i>	ublox EVK-M8N	0.1	0.02	m/s	
Average plane error		15	2.25	m	
Average height error		20	2.45	m	
Average velocity error		0.1	0.02	m/s	
- Poor Reception Mode					
Plane error <i>GLONASS</i>	ublox EVK-M8N	40	10.72	m	
Height error <i>GLONASS</i>	ublox EVK-M8N	20	5.54	m	
Velocity error <i>GLONASS</i>	ublox EVK-M8N	0.1	0.07	m/s	
Plane error <i>GPS</i>	ublox EVK-M8N	40	0.88	m	
Height error <i>GPS</i>	ublox EVK-M8N	20	0.67	m	
Velocity error <i>GPS</i>	ublox EVK-M8N	0.1	0.02	m/s	
Plane error <i>GLONASS/GPS</i>	ublox EVK-M8N	40	4.17	m	
Height error <i>GLONASS/GPS</i>	ublox EVK-M8N	20	3.23	m	
Velocity error <i>GLONASS/GPS</i>	ublox EVK-M8N	0.1	0.01	m/s	
Average plane error		40	5.26	m	
Average height error		20	3.15	m	
Average velocity error		0.1	0.03	m/s	
--- Total Averages ---					
Average plane error		15	3.3	m	
Average height error		20	2.67	m	
Average velocity error		0.1	0.02	m/s	
Test result					Passed

GOST_R_55534: 5.9 - Minimum update rate of NMEA stream

Test Items and Conditions	DUT	Threshold	Result	Unit	Status
Equal adjacent coordinates			NO		
Test result					Passed

GOST_R_55534: 5.10 - Reacquisition time

<i>Test Items and Conditions</i>	DUT	Threshold	Result	Unit	Status
Average Position fix time in tracking mode <i>GLONASS/GPS</i>	ublox EVK-M8N	5	1.11	s	
Test result					Passed

GOST_R_55534: 5.11 - Time-to-first fix (TTFF) under cold start conditions

<i>Test Items and Conditions</i>	DUT	Threshold	Result	Unit	Status
Average Position fix time in cold start mode <i>GLONASS/GPS</i>	ublox EVK-M8N	60	35.57	s	
Test result					Passed

GOST_R_55534: 5.12 - Tracking and acquisition sensitivity

<i>Test Items and Conditions</i>	DUT	Threshold	Result	Unit	Status
Acquisition mode sensitivity <i>GLONASS/GPS</i>	ublox EVK-M8N	-163	-175	dBW	
Tracking mode sensitivity <i>GLONASS/GPS</i>	ublox EVK-M8N	-188	-191	dBW	
Test result					Passed

GOST_R_55534: 5.13 - Change update rate of NMEA stream

<i>Test Items and Conditions</i>	DUT	Threshold	Result	Unit	Status
GNSS Data Rate 1 Hz: Jitter tolerance 50%	ublox EVK-M8N	500	120	ms	
GNSS Data Rate 2 Hz: Jitter tolerance 50%	ublox EVK-M8N	250	121	ms	
Test result					Passed

GOST_R_55534: 5.14 - Check cutoff angle settings for navigation satellites

<i>Test Items and Conditions</i>	DUT	Result	Elapsed Time	Unit	Status
Satellite removed from Navigation solution at cut-off angle 5 degree: GLONASS SVID 11, Expected Time 105 s	ublox EVK-M8N	YES	106.48	s	
Satellite removed from Navigation solution at cut-off angle 15 degree: GLONASS SVID 18, Expected Time 230 s	ublox EVK-M8N	YES	231.46	s	
Test result					Passed

GOST_R_55534: 5.15 - Checking power-off time of navigation module

Test Items and Conditions	DUT	Measurement Time	Result	Unit	Status
Power off time	ublox EVK-M8N	1.50		Second	
Test result					Passed

The last table lists all errors and warnings collected during the test execution.

Annex: Errors and Warnings

Message	Test	Testcase	
Errors and Warnings			
[TC::NMEA] Total number of active satellites (20) in GSA sentence differs from total number of used satellites for solution (12) in GGA sentence	GOST_R_55534	Testcase53	Warning
[TC::NMEA] Total number of active satellites (18) in GSA sentence differs from total number of used satellites for solution (12) in GGA sentence	GOST_R_55534	Testcase54	Warning

The results with NMEA measurements and calculations are stored in CSV file on the controller PC in SCPI report folder. The following naming conventions for the result files are applied:

<Test case>-<DUT>-<navigation system>-<coordinate system [-extension]>-<date><time>.csv

- Test case: TC51, TC52...
- DUT: The name of device under test
- Navigation system: GL (for GLONASS), GP (for GPS), GN (for GNSS)
- Coordinate system: W (for WGS84), P (for PZ90)
- Extension: F (for full reception), P (for pure reception), B (for blockage mode)
- Date: yyyy-mm-dd
- Time: hh-mm-ss

The test module provides measurement results in line with the GOST 33471 or GOST R 55534 specification (selectable).

The results are displayed in the measurement report. There is a separate table for each test showing tested GNSS standard.

7 Monitoring

This option provides a "GNSS Monitor" subtab of a test plans pane.

After the execution of the test module, you can open a monitoring view via "GNSS Monitoring" link in a web browser.

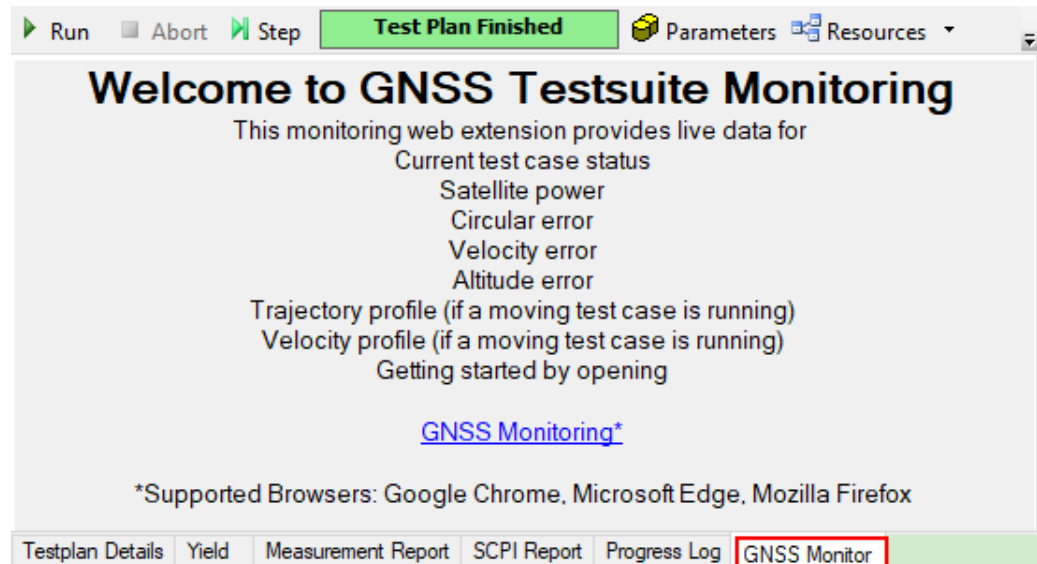

In the monitoring view, you find a graphical representation of measured signal characteristics. The monitoring view consists of a main view ("Welcome to GNSS Testsuit Monitoring") and several views that can be dragged and dropped to the main pane via buttons to the right.

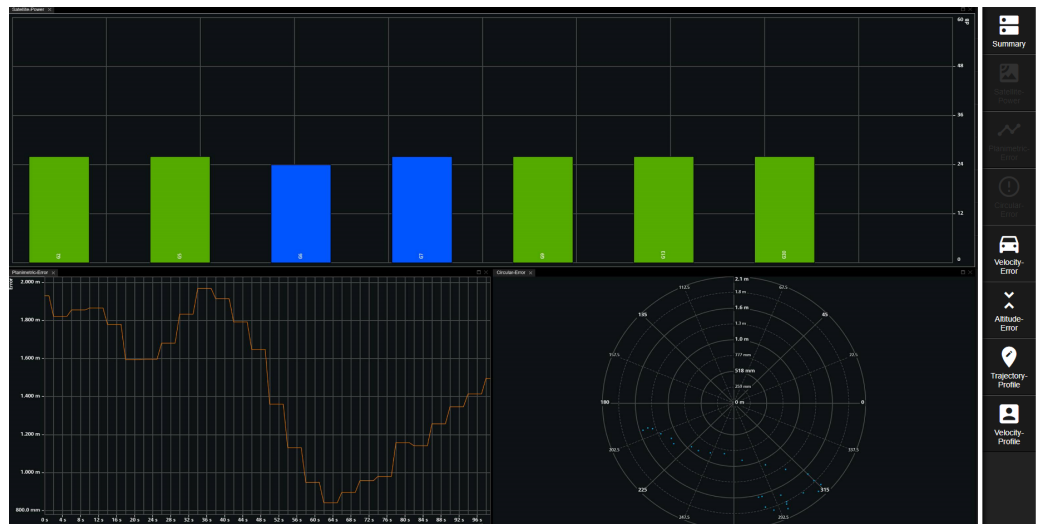

The views can be opened using the buttons to the right via drag and drop to the main view. A button of an opened view changes to gray. You can resize or close particular active view.

The following monitoring views are supported:

- **"Summary"** : lists the testcase name, overall elapsed time, position fix and position fix mode
- **"Satellite Power"** : displays the satellite signal level (in dB) vs time
Blue satellites are only tracked. The IVS does not use their positioning data.
- **"Planimetric Error"** : displays the position estimation error (in meters) vs time
- **"Circular Error"** : displays the position estimation error (in meters) vs angle
- **"Velocity Error"** : displays the measured velocity error (in meters per second) vs time
- **"Altitude Error"** : displays the altitude estimation error (in meters) vs time
- **"Trajectory Profile"** : displays the trajectory length (in km) vs position (distance in km)
- **"Velocity Profile"** : displays the velocity (in meters per second) vs position (distance in 100 m)

8 Test module details

The tests configure and control the simulated GNSS.

For each test case, the test automatically configures and controls the IVS, as required for the test case.

The test executes all test cases listed with an enabled checkbox.