

R&S® TSME

Ultracompact Drive Test Scanner

User Manual



1514654202

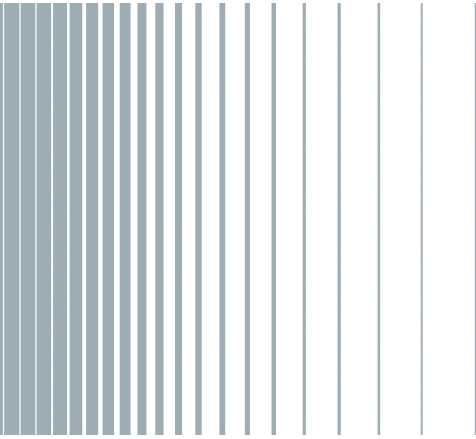

This manual describes the following R&S®TSME models and options:

- R&S®TSME (1514.6520K02)
- TD-SCDMA Option R&S®TSME-K20 (1510.0079.02)
- WCDMA Scanner Option R&S®TSME-K21 (1514.6820.02)
- CDMA2000® Option R&S®TSME-K22 (1514.6836.02)
- GSM Scanner Option R&S®TSME-K23 (1510.0085.02)
- 1xEVDO Option R&S®TSME-K24 (1510.0010.02)
- CW Scanner Option R&S®TSME-K25 (1522.6954.02)
- TETRA Scanner Option R&S®TSME-K26 (1514.6920.02)
- RF Power Scan Option R&S®TSME-K27 (1514.6813.02)
- WiMAX Scanner Option R&S®TSME-K28 (1514.6842.02)
- LTE Scanner Option R&S®TSME-K29 (1514.6859.02)
- LTE MIMO 2x2, 4x2, 4x4 R&S®TSME-K30 (1514.6871.02)
- LTE DL Allocation Analyzer R&S®TSME-K31 (1522.6990.02)
- LTE eMBMS Option R&S®TSME-K32 (1522.6960.02)
- LTE UL Allocation Analyzer R&S®TSME-K33 (4900.5112.02)
- NB-IoT/Cat NB1 Scanning R&S®TSME-K34 (1522.6731.02)
- Automatic Channel Detection R&S®TSME-K40 (1514.7232.02)

© 2020 Rohde & Schwarz GmbH & Co. KG

Mühlhofstr. 15, 81671 München, Germany

Phone: +49 89 41 29 - 0

Fax: +49 89 41 29 12 164

E-mail: info@rohde-schwarz.com

Internet: www.rohde-schwarz.com

Subject to change – Data without tolerance limits is not binding.

R&S® is a registered trademark of Rohde & Schwarz GmbH & Co. KG.

CDMA2000® is a registered trademark of the Telecommunications Industry Association (TIA -USA).

WiMAX Forum® is a registered trademark of the WiMAX Forum. WiMAX™, the WiMAX Forum logo, WiMAX Forum Certified™ and the WiMAX Forum Certified logo are trademarks of the WiMAX Forum.

Trade names are trademarks of the owners.

1514.6542.02 | Version 12 | R&S®TSME

The following abbreviations are used throughout this manual: R&S®TSME is abbreviated as R&S TSME.

Basic Safety Instructions

Always read through and comply with the following safety instructions!

All plants and locations of the Rohde & Schwarz group of companies make every effort to keep the safety standards of our products up to date and to offer our customers the highest possible degree of safety. Our products and the auxiliary equipment they require are designed, built and tested in accordance with the safety standards that apply in each case. Compliance with these standards is continuously monitored by our quality assurance system. The product described here has been designed, built and tested in accordance with the EC Certificate of Conformity and has left the manufacturer's plant in a condition fully complying with safety standards. To maintain this condition and to ensure safe operation, you must observe all instructions and warnings provided in this manual. If you have any questions regarding these safety instructions, the Rohde & Schwarz group of companies will be happy to answer them.







Furthermore, it is your responsibility to use the product in an appropriate manner. This product is designed for use solely in industrial and laboratory environments or, if expressly permitted, also in the field and must not be used in any way that may cause personal injury or property damage. You are responsible if the product is used for any purpose other than its designated purpose or in disregard of the manufacturer's instructions. The manufacturer shall assume no responsibility for such use of the product.

The product is used for its designated purpose if it is used in accordance with its product documentation and within its performance limits (see data sheet, documentation, the following safety instructions). Using the product requires technical skills and, in some cases, a basic knowledge of English. It is therefore essential that only skilled and specialized staff or thoroughly trained personnel with the required skills be allowed to use the product. If personal safety gear is required for using Rohde & Schwarz products, this will be indicated at the appropriate place in the product documentation. Keep the basic safety instructions and the product documentation in a safe place and pass them on to the subsequent users.











Observing the safety instructions will help prevent personal injury or damage of any kind caused by dangerous situations. Therefore, carefully read through and adhere to the following safety instructions before and when using the product. It is also absolutely essential to observe the additional safety instructions on personal safety, for example, that appear in relevant parts of the product documentation. In these safety instructions, the word "product" refers to all merchandise sold and distributed by the Rohde & Schwarz group of companies, including instruments, systems and all accessories. For product-specific information, see the data sheet and the product documentation.

Safety labels on products

The following safety labels are used on products to warn against risks and dangers.

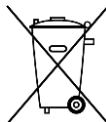
Symbol	Meaning	Symbol	Meaning
	Notice, general danger location Observe product documentation		ON/OFF Power
	Caution when handling heavy equipment		Standby indication
	Danger of electric shock		Direct current (DC)

Basic Safety Instructions

Symbol	Meaning	Symbol	Meaning
	Caution ! Hot surface		Alternating current (AC)
	Protective conductor terminal To identify any terminal which is intended for connection to an external conductor for protection against electric shock in case of a fault, or the terminal of a protective earth		Direct/alternating current (DC/AC)
	Earth (Ground)		Class II Equipment to identify equipment meeting the safety requirements specified for Class II equipment (device protected by double or reinforced insulation)
	Frame or chassis Ground terminal		EU labeling for batteries and accumulators For additional information, see section "Waste disposal/Environmental protection", item 1.
	Be careful when handling electrostatic sensitive devices		EU labeling for separate collection of electrical and electronic devices For additional information, see section "Waste disposal/Environmental protection", item 2.
	Warning! Laser radiation For additional information, see section "Operation", item 7.		

Signal words and their meaning

The following signal words are used in the product documentation in order to warn the reader about risks and dangers.



Indicates a hazardous situation which, if not avoided, will result in death or serious injury.



Indicates a hazardous situation which, if not avoided, could result in death or serious injury.



Indicates a hazardous situation which, if not avoided, could result in minor or moderate injury.



Indicates information considered important, but not hazard-related, e.g. messages relating to property damage.

In the product documentation, the word ATTENTION is used synonymously.

These signal words are in accordance with the standard definition for civil applications in the European Economic Area. Definitions that deviate from the standard definition may also exist in other economic areas or military applications. It is therefore essential to make sure that the signal words described here are always used only in connection with the related product documentation and the related product. The use of signal words in connection with unrelated products or documentation can result in misinterpretation and in personal injury or material damage.

Basic Safety Instructions

Operating states and operating positions

The product may be operated only under the operating conditions and in the positions specified by the manufacturer, without the product's ventilation being obstructed. If the manufacturer's specifications are not observed, this can result in electric shock, fire and/or serious personal injury or death. Applicable local or national safety regulations and rules for the prevention of accidents must be observed in all work performed.

1. Unless otherwise specified, the following requirements apply to Rohde & Schwarz products: predefined operating position is always with the housing floor facing down, IP protection 2X, use only indoors, max. operating altitude 2000 m above sea level, max. transport altitude 4500 m above sea level. A tolerance of $\pm 10\%$ shall apply to the nominal voltage and $\pm 5\%$ to the nominal frequency, overvoltage category 2, pollution degree 2.
2. Do not place the product on surfaces, vehicles, cabinets or tables that for reasons of weight or stability are unsuitable for this purpose. Always follow the manufacturer's installation instructions when installing the product and fastening it to objects or structures (e.g. walls and shelves). An installation that is not carried out as described in the product documentation could result in personal injury or even death.
3. Do not place the product on heat-generating devices such as radiators or fan heaters. The ambient temperature must not exceed the maximum temperature specified in the product documentation or in the data sheet. Product overheating can cause electric shock, fire and/or serious personal injury or even death.

Electrical safety

If the information on electrical safety is not observed either at all or to the extent necessary, electric shock, fire and/or serious personal injury or death may occur.

1. Prior to switching on the product, always ensure that the nominal voltage setting on the product matches the nominal voltage of the mains-supply network. If a different voltage is to be set, the power fuse of the product may have to be changed accordingly.
2. In the case of products of safety class I with movable power cord and connector, operation is permitted only on sockets with a protective conductor contact and protective conductor.
3. Intentionally breaking the protective conductor either in the feed line or in the product itself is not permitted. Doing so can result in the danger of an electric shock from the product. If extension cords or connector strips are implemented, they must be checked on a regular basis to ensure that they are safe to use.
4. If there is no power switch for disconnecting the product from the mains, or if the power switch is not suitable for this purpose, use the plug of the connecting cable to disconnect the product from the mains. In such cases, always ensure that the power plug is easily reachable and accessible at all times. For example, if the power plug is the disconnecting device, the length of the connecting cable must not exceed 3 m. Functional or electronic switches are not suitable for providing disconnection from the AC supply network. If products without power switches are integrated into racks or systems, the disconnecting device must be provided at the system level.
5. Never use the product if the power cable is damaged. Check the power cables on a regular basis to ensure that they are in proper operating condition. By taking appropriate safety measures and carefully laying the power cable, ensure that the cable cannot be damaged and that no one can be hurt by, for example, tripping over the cable or suffering an electric shock.

Basic Safety Instructions

6. The product may be operated only from TN/TT supply networks fuse-protected with max. 16 A (higher fuse only after consulting with the Rohde & Schwarz group of companies).
7. Do not insert the plug into sockets that are dusty or dirty. Insert the plug firmly and all the way into the socket provided for this purpose. Otherwise, sparks that result in fire and/or injuries may occur.
8. Do not overload any sockets, extension cords or connector strips; doing so can cause fire or electric shocks.
9. For measurements in circuits with voltages $V_{rms} > 30$ V, suitable measures (e.g. appropriate measuring equipment, fuse protection, current limiting, electrical separation, insulation) should be taken to avoid any hazards.
10. Ensure that the connections with information technology equipment, e.g. PCs or other industrial computers, comply with the IEC 60950-1 / EN 60950-1 or IEC 61010-1 / EN 61010-1 standards that apply in each case.
11. Unless expressly permitted, never remove the cover or any part of the housing while the product is in operation. Doing so will expose circuits and components and can lead to injuries, fire or damage to the product.
12. If a product is to be permanently installed, the connection between the protective conductor terminal on site and the product's protective conductor must be made first before any other connection is made. The product may be installed and connected only by a licensed electrician.
13. For permanently installed equipment without built-in fuses, circuit breakers or similar protective devices, the supply circuit must be fuse-protected in such a way that anyone who has access to the product, as well as the product itself, is adequately protected from injury or damage.
14. Use suitable overvoltage protection to ensure that no overvoltage (such as that caused by a bolt of lightning) can reach the product. Otherwise, the person operating the product will be exposed to the danger of an electric shock.
15. Any object that is not designed to be placed in the openings of the housing must not be used for this purpose. Doing so can cause short circuits inside the product and/or electric shocks, fire or injuries.
16. Unless specified otherwise, products are not liquid-proof (see also section "Operating states and operating positions", item 1). Therefore, the equipment must be protected against penetration by liquids. If the necessary precautions are not taken, the user may suffer electric shock or the product itself may be damaged, which can also lead to personal injury.
17. Never use the product under conditions in which condensation has formed or can form in or on the product, e.g. if the product has been moved from a cold to a warm environment. Penetration by water increases the risk of electric shock.
18. Prior to cleaning the product, disconnect it completely from the power supply (e.g. AC supply network or battery). Use a soft, non-linting cloth to clean the product. Never use chemical cleaning agents such as alcohol, acetone or diluents for cellulose lacquers.

Operation

1. Operating the products requires special training and intense concentration. Make sure that persons who use the products are physically, mentally and emotionally fit enough to do so; otherwise, injuries or material damage may occur. It is the responsibility of the employer/operator to select suitable personnel for operating the products.

Basic Safety Instructions

2. Before you move or transport the product, read and observe the section titled "Transport".
3. As with all industrially manufactured goods, the use of substances that induce an allergic reaction (allergens) such as nickel cannot be generally excluded. If you develop an allergic reaction (such as a skin rash, frequent sneezing, red eyes or respiratory difficulties) when using a Rohde & Schwarz product, consult a physician immediately to determine the cause and to prevent health problems or stress.
4. Before you start processing the product mechanically and/or thermally, or before you take it apart, be sure to read and pay special attention to the section titled "Waste disposal/Environmental protection", item 1.
5. Depending on the function, certain products such as RF radio equipment can produce an elevated level of electromagnetic radiation. Considering that unborn babies require increased protection, pregnant women must be protected by appropriate measures. Persons with pacemakers may also be exposed to risks from electromagnetic radiation. The employer/operator must evaluate workplaces where there is a special risk of exposure to radiation and, if necessary, take measures to avert the potential danger.
6. Should a fire occur, the product may release hazardous substances (gases, fluids, etc.) that can cause health problems. Therefore, suitable measures must be taken, e.g. protective masks and protective clothing must be worn.
7. Laser products are given warning labels that are standardized according to their laser class. Lasers can cause biological harm due to the properties of their radiation and due to their extremely concentrated electromagnetic power. If a laser product (e.g. a CD/DVD drive) is integrated into a Rohde & Schwarz product, absolutely no other settings or functions may be used as described in the product documentation. The objective is to prevent personal injury (e.g. due to laser beams).
8. EMC classes (in line with EN 55011/CISPR 11, and analogously with EN 55022/CISPR 22, EN 55032/CISPR 32)
 - Class A equipment:
Equipment suitable for use in all environments except residential environments and environments that are directly connected to a low-voltage supply network that supplies residential buildings
Note: Class A equipment is intended for use in an industrial environment. This equipment may cause radio disturbances in residential environments, due to possible conducted as well as radiated disturbances. In this case, the operator may be required to take appropriate measures to eliminate these disturbances.
 - Class B equipment:
Equipment suitable for use in residential environments and environments that are directly connected to a low-voltage supply network that supplies residential buildings

Repair and service

1. The product may be opened only by authorized, specially trained personnel. Before any work is performed on the product or before the product is opened, it must be disconnected from the AC supply network. Otherwise, personnel will be exposed to the risk of an electric shock.

Basic Safety Instructions

- Adjustments, replacement of parts, maintenance and repair may be performed only by electrical experts authorized by Rohde & Schwarz. Only original parts may be used for replacing parts relevant to safety (e.g. power switches, power transformers, fuses). A safety test must always be performed after parts relevant to safety have been replaced (visual inspection, protective conductor test, insulation resistance measurement, leakage current measurement, functional test). This helps ensure the continued safety of the product.

Batteries and rechargeable batteries/cells

If the information regarding batteries and rechargeable batteries/cells is not observed either at all or to the extent necessary, product users may be exposed to the risk of explosions, fire and/or serious personal injury, and, in some cases, death. Batteries and rechargeable batteries with alkaline electrolytes (e.g. lithium cells) must be handled in accordance with the EN 62133 standard.

- Cells must not be taken apart or crushed.
- Cells or batteries must not be exposed to heat or fire. Storage in direct sunlight must be avoided. Keep cells and batteries clean and dry. Clean soiled connectors using a dry, clean cloth.
- Cells or batteries must not be short-circuited. Cells or batteries must not be stored in a box or in a drawer where they can short-circuit each other, or where they can be short-circuited by other conductive materials. Cells and batteries must not be removed from their original packaging until they are ready to be used.
- Cells and batteries must not be exposed to any mechanical shocks that are stronger than permitted.
- If a cell develops a leak, the fluid must not be allowed to come into contact with the skin or eyes. If contact occurs, wash the affected area with plenty of water and seek medical aid.
- Improperly replacing or charging cells or batteries that contain alkaline electrolytes (e.g. lithium cells) can cause explosions. Replace cells or batteries only with the matching Rohde & Schwarz type (see parts list) in order to ensure the safety of the product.
- Cells and batteries must be recycled and kept separate from residual waste. Rechargeable batteries and normal batteries that contain lead, mercury or cadmium are hazardous waste. Observe the national regulations regarding waste disposal and recycling.
- Follow the transport stipulations of the carrier (IATA-DGR, IMDG-Code, ADR, RID) when returning lithium batteries to Rohde & Schwarz subsidiaries.

Transport

- The product may be very heavy. Therefore, the product must be handled with care. In some cases, the user may require a suitable means of lifting or moving the product (e.g. with a lift-truck) to avoid back or other physical injuries.
- Handles on the products are designed exclusively to enable personnel to transport the product. It is therefore not permissible to use handles to fasten the product to or on transport equipment such as cranes, fork lifts, wagons, etc. The user is responsible for securely fastening the products to or on the means of transport or lifting. Observe the safety regulations of the manufacturer of the means of transport or lifting. Noncompliance can result in personal injury or material damage.

Basic Safety Instructions

3. If you use the product in a vehicle, it is the sole responsibility of the driver to drive the vehicle safely and properly. The manufacturer assumes no responsibility for accidents or collisions. Never use the product in a moving vehicle if doing so could distract the driver of the vehicle. Adequately secure the product in the vehicle to prevent injuries or other damage in the event of an accident.

Waste disposal/Environmental protection

1. Specially marked equipment has a battery or accumulator that must not be disposed of with unsorted municipal waste, but must be collected separately. It may only be disposed of at a suitable collection point or via a Rohde & Schwarz customer service center.
2. Waste electrical and electronic equipment must not be disposed of with unsorted municipal waste, but must be collected separately.
Rohde & Schwarz GmbH & Co. KG has developed a disposal concept and takes full responsibility for take-back obligations and disposal obligations for manufacturers within the EU. Contact your Rohde & Schwarz customer service center for environmentally responsible disposal of the product.
3. If products or their components are mechanically and/or thermally processed in a manner that goes beyond their intended use, hazardous substances (heavy-metal dust such as lead, beryllium, nickel) may be released. For this reason, the product may only be disassembled by specially trained personnel. Improper disassembly may be hazardous to your health. National waste disposal regulations must be observed.
4. If handling the product releases hazardous substances or fuels that must be disposed of in a special way, e.g. coolants or engine oils that must be replenished regularly, the safety instructions of the manufacturer of the hazardous substances or fuels and the applicable regional waste disposal regulations must be observed. Also observe the relevant safety instructions in the product documentation. The improper disposal of hazardous substances or fuels can cause health problems and lead to environmental damage.

For additional information about environmental protection, visit the Rohde & Schwarz website.

Instrucciones de seguridad elementales

¡Es imprescindible leer y cumplir las siguientes instrucciones e informaciones de seguridad!

El principio del grupo de empresas Rohde & Schwarz consiste en tener nuestros productos siempre al día con los estándares de seguridad y de ofrecer a nuestros clientes el máximo grado de seguridad. Nuestros productos y todos los equipos adicionales son siempre fabricados y examinados según las normas de seguridad vigentes. Nuestro sistema de garantía de calidad controla constantemente que sean cumplidas estas normas. El presente producto ha sido fabricado y examinado según el certificado de conformidad de la UE y ha salido de nuestra planta en estado impecable según los estándares técnicos de seguridad. Para poder preservar este estado y garantizar un funcionamiento libre de peligros, el usuario deberá atenerse a todas las indicaciones, informaciones de seguridad y notas de alerta. El grupo de empresas Rohde & Schwarz está siempre a su disposición en caso de que tengan preguntas referentes a estas informaciones de seguridad.

Además queda en la responsabilidad del usuario utilizar el producto en la forma debida. Este producto está destinado exclusivamente al uso en la industria y el laboratorio o, si ha sido expresamente autorizado, para aplicaciones de campo y de ninguna manera deberá ser utilizado de modo que alguna persona/cosa pueda sufrir daño. El uso del producto fuera de sus fines definidos o sin tener en cuenta las instrucciones del fabricante queda en la responsabilidad del usuario. El fabricante no se hace en ninguna forma responsable de consecuencias a causa del mal uso del producto.

















Se parte del uso correcto del producto para los fines definidos si el producto es utilizado conforme a las indicaciones de la correspondiente documentación del producto y dentro del margen de rendimiento definido (ver hoja de datos, documentación, informaciones de seguridad que siguen). El uso del producto hace necesarios conocimientos técnicos y ciertos conocimientos del idioma inglés. Por eso se debe tener en cuenta que el producto solo pueda ser operado por personal especializado o personas instruidas en profundidad con las capacidades correspondientes. Si fuera necesaria indumentaria de seguridad para el uso de productos de Rohde & Schwarz, encontraría la información debida en la documentación del producto en el capítulo correspondiente. Guarde bien las informaciones de seguridad elementales, así como la documentación del producto, y entréguelas a usuarios posteriores.

Tener en cuenta las informaciones de seguridad sirve para evitar en lo posible lesiones o daños por peligros de toda clase. Por eso es imprescindible leer detalladamente y comprender por completo las siguientes informaciones de seguridad antes de usar el producto, y respetarlas durante el uso del producto. Deberán tenerse en cuenta todas las demás informaciones de seguridad, como p. ej. las referentes a la protección de personas, que encontrarán en el capítulo correspondiente de la documentación del producto y que también son de obligado cumplimiento. En las presentes informaciones de seguridad se recogen todos los objetos que distribuye el grupo de empresas Rohde & Schwarz bajo la denominación de "producto", entre ellos también aparatos, instalaciones así como toda clase de accesorios. Los datos específicos del producto figuran en la hoja de datos y en la documentación del producto.

Instrucciones de seguridad elementales

Señalización de seguridad de los productos

Las siguientes señales de seguridad se utilizan en los productos para advertir sobre riesgos y peligros.

Símbolo	Significado	Símbolo	Significado
	Aviso: punto de peligro general Observar la documentación del producto		Tensión de alimentación de PUESTA EN MARCHA / PARADA
	Atención en el manejo de dispositivos de peso elevado		Indicación de estado de espera (standby)
	Peligro de choque eléctrico		Corriente continua (DC)
	Advertencia: superficie caliente		Corriente alterna (AC)
	Conexión a conductor de protección		Corriente continua / Corriente alterna (DC/AC)
	Conexión a tierra		El aparato está protegido en su totalidad por un aislamiento doble (reforzado)
	Conexión a masa		Distintivo de la UE para baterías y acumuladores Más información en la sección "Eliminación/protección del medio ambiente", punto 1.
	Aviso: Cuidado en el manejo de dispositivos sensibles a la electrostática (ESD)		Distintivo de la UE para la eliminación por separado de dispositivos eléctricos y electrónicos Más información en la sección "Eliminación/protección del medio ambiente", punto 2.
	Advertencia: rayo láser Más información en la sección "Funcionamiento", punto 7.		

Instrucciones de seguridad elementales

Palabras de señal y su significado

En la documentación del producto se utilizan las siguientes palabras de señal con el fin de advertir contra riesgos y peligros.



Indica una situación de peligro que, si no se evita, causa lesiones graves o incluso la muerte.



Indica una situación de peligro que, si no se evita, puede causar lesiones graves o incluso la muerte.



Indica una situación de peligro que, si no se evita, puede causar lesiones leves o moderadas.



Indica información que se considera importante, pero no en relación con situaciones de peligro; p. ej., avisos sobre posibles daños materiales.

En la documentación del producto se emplea de forma sinónima el término CUIDADO.

Las palabras de señal corresponden a la definición habitual para aplicaciones civiles en el área económica europea. Pueden existir definiciones diferentes a esta definición en otras áreas económicas o en aplicaciones militares. Por eso se deberá tener en cuenta que las palabras de señal aquí descritas sean utilizadas siempre solamente en combinación con la correspondiente documentación del producto y solamente en combinación con el producto correspondiente. La utilización de las palabras de señal en combinación con productos o documentaciones que no les correspondan puede llevar a interpretaciones equivocadas y tener por consecuencia daños en personas u objetos.

Estados operativos y posiciones de funcionamiento

El producto solamente debe ser utilizado según lo indicado por el fabricante respecto a los estados operativos y posiciones de funcionamiento sin que se obstruya la ventilación. Si no se siguen las indicaciones del fabricante, pueden producirse choques eléctricos, incendios y/o lesiones graves con posible consecuencia de muerte. En todos los trabajos deberán ser tenidas en cuenta las normas nacionales y locales de seguridad del trabajo y de prevención de accidentes.

1. Si no se convino de otra manera, es para los productos Rohde & Schwarz válido lo que sigue: como posición de funcionamiento se define por principio la posición con el suelo de la caja para abajo, modo de protección IP 2X, uso solamente en estancias interiores, utilización hasta 2000 m sobre el nivel del mar, transporte hasta 4500 m sobre el nivel del mar. Se aplicará una tolerancia de $\pm 10\%$ sobre el voltaje nominal y de $\pm 5\%$ sobre la frecuencia nominal. Categoría de sobrecarga eléctrica 2, índice de suciedad 2.
2. No sitúe el producto encima de superficies, vehículos, estantes o mesas, que por sus características de peso o de estabilidad no sean aptos para él. Siga siempre las instrucciones de instalación del fabricante cuando instale y asegure el producto en objetos o estructuras (p. ej. paredes y estantes). Si se realiza la instalación de modo distinto al indicado en la documentación del producto, se pueden causar lesiones o, en determinadas circunstancias, incluso la muerte.
3. No ponga el producto sobre aparatos que generen calor (p. ej. radiadores o calefactores). La temperatura ambiente no debe superar la temperatura máxima especificada en la documentación del producto o en la hoja de datos. En caso de sobrecalentamiento del producto, pueden producirse choques eléctricos, incendios y/o lesiones graves con posible consecuencia de muerte.

Instrucciones de seguridad elementales

Seguridad eléctrica

Si no se siguen (o se siguen de modo insuficiente) las indicaciones del fabricante en cuanto a seguridad eléctrica, pueden producirse choques eléctricos, incendios y/o lesiones graves con posible consecuencia de muerte.

1. Antes de la puesta en marcha del producto se deberá comprobar siempre que la tensión preseleccionada en el producto coincida con la de la red de alimentación eléctrica. Si es necesario modificar el ajuste de tensión, también se deberán cambiar en caso dado los fusibles correspondientes del producto.
2. Los productos de la clase de protección I con alimentación móvil y enchufe individual solamente podrán enchufarse a tomas de corriente con contacto de seguridad y con conductor de protección conectado.
3. Queda prohibida la interrupción intencionada del conductor de protección, tanto en la toma de corriente como en el mismo producto. La interrupción puede tener como consecuencia el riesgo de que el producto sea fuente de choques eléctricos. Si se utilizan cables alargadores o regletas de enchufe, deberá garantizarse la realización de un examen regular de los mismos en cuanto a su estado técnico de seguridad.
4. Si el producto no está equipado con un interruptor para desconectarlo de la red, o bien si el interruptor existente no resulta apropiado para la desconexión de la red, el enchufe del cable de conexión se deberá considerar como un dispositivo de desconexión. El dispositivo de desconexión se debe poder alcanzar fácilmente y debe estar siempre bien accesible. Si, p. ej., el enchufe de conexión a la red es el dispositivo de desconexión, la longitud del cable de conexión no debe superar 3 m). Los interruptores selectores o electrónicos no son aptos para el corte de la red eléctrica. Si se integran productos sin interruptor en bastidores o instalaciones, se deberá colocar el interruptor en el nivel de la instalación.
5. No utilice nunca el producto si está dañado el cable de conexión a red. Compruebe regularmente el correcto estado de los cables de conexión a red. Asegúrese, mediante las medidas de protección y de instalación adecuadas, de que el cable de conexión a red no pueda ser dañado o de que nadie pueda ser dañado por él, p. ej. al tropezar o por un choque eléctrico.
6. Solamente está permitido el funcionamiento en redes de alimentación TN/TT aseguradas con fusibles de 16 A como máximo (utilización de fusibles de mayor amperaje solo previa consulta con el grupo de empresas Rohde & Schwarz).
7. Nunca conecte el enchufe en tomas de corriente sucias o llenas de polvo. Introduzca el enchufe por completo y fuertemente en la toma de corriente. La no observación de estas medidas puede provocar chispas, fuego y/o lesiones.
8. No sobrecargue las tomas de corriente, los cables alargadores o las regletas de enchufe ya que esto podría causar fuego o choques eléctricos.
9. En las mediciones en circuitos de corriente con una tensión $U_{\text{eff}} > 30 \text{ V}$ se deberán tomar las medidas apropiadas para impedir cualquier peligro (p. ej. medios de medición adecuados, seguros, limitación de tensión, corte protector, aislamiento etc.).
10. Para la conexión con dispositivos informáticos como un PC o un ordenador industrial, debe comprobarse que éstos cumplan los estándares IEC60950-1/EN60950-1 o IEC61010-1/EN 61010-1 válidos en cada caso.

Instrucciones de seguridad elementales

11. A menos que esté permitido expresamente, no retire nunca la tapa ni componentes de la carcasa mientras el producto esté en servicio. Esto pone a descubierto los cables y componentes eléctricos y puede causar lesiones, fuego o daños en el producto.
12. Si un producto se instala en un lugar fijo, se deberá primero conectar el conductor de protección fijo con el conductor de protección del producto antes de hacer cualquier otra conexión. La instalación y la conexión deberán ser efectuadas por un electricista especializado.
13. En el caso de dispositivos fijos que no estén provistos de fusibles, interruptor automático ni otros mecanismos de seguridad similares, el circuito de alimentación debe estar protegido de modo que todas las personas que puedan acceder al producto, así como el producto mismo, estén a salvo de posibles daños.
14. Todo producto debe estar protegido contra sobretensión (debida p. ej. a una caída del rayo) mediante los correspondientes sistemas de protección. Si no, el personal que lo utilice quedará expuesto al peligro de choque eléctrico.
15. No debe introducirse en los orificios de la caja del aparato ningún objeto que no esté destinado a ello. Esto puede producir cortocircuitos en el producto y/o puede causar choques eléctricos, fuego o lesiones.
16. Salvo indicación contraria, los productos no están impermeabilizados (ver también el capítulo "Estados operativos y posiciones de funcionamiento", punto 1). Por eso es necesario tomar las medidas necesarias para evitar la entrada de líquidos. En caso contrario, existe peligro de choque eléctrico para el usuario o de daños en el producto, que también pueden redundar en peligro para las personas.
17. No utilice el producto en condiciones en las que pueda producirse o ya se hayan producido condensaciones sobre el producto o en el interior de éste, como p. ej. al desplazarlo de un lugar frío a otro caliente. La entrada de agua aumenta el riesgo de choque eléctrico.
18. Antes de la limpieza, desconecte por completo el producto de la alimentación de tensión (p. ej. red de alimentación o batería). Realice la limpieza de los aparatos con un paño suave, que no se deshilache. No utilice bajo ningún concepto productos de limpieza químicos como alcohol, acetona o diluyentes para lacas nitrocelulósicas.

Funcionamiento

1. El uso del producto requiere instrucciones especiales y una alta concentración durante el manejo. Debe asegurarse que las personas que manejen el producto estén a la altura de los requerimientos necesarios en cuanto a aptitudes físicas, psíquicas y emocionales, ya que de otra manera no se pueden excluir lesiones o daños de objetos. El empresario u operador es responsable de seleccionar el personal usuario apto para el manejo del producto.
2. Antes de desplazar o transportar el producto, lea y tenga en cuenta el capítulo "Transporte".
3. Como con todo producto de fabricación industrial no puede quedar excluida en general la posibilidad de que se produzcan alergias provocadas por algunos materiales empleados —los llamados alérgenos (p. ej. el níquel)—. Si durante el manejo de productos Rohde & Schwarz se producen reacciones alérgicas, como p. ej. irritaciones cutáneas, estornudos continuos, enrojecimiento de la conjuntiva o dificultades respiratorias, debe avisarse inmediatamente a un médico para investigar las causas y evitar cualquier molestia o daño a la salud.
4. Antes de la manipulación mecánica y/o térmica o el desmontaje del producto, debe tenerse en cuenta imprescindiblemente el capítulo "Eliminación/protección del medio ambiente", punto 1.

Instrucciones de seguridad elementales

5. Ciertos productos, como p. ej. las instalaciones de radiocomunicación RF, pueden a causa de su función natural, emitir una radiación electromagnética aumentada. Deben tomarse todas las medidas necesarias para la protección de las mujeres embarazadas. También las personas con marcapasos pueden correr peligro a causa de la radiación electromagnética. El empresario/operador tiene la obligación de evaluar y señalar las áreas de trabajo en las que exista un riesgo elevado de exposición a radiaciones.
6. Tenga en cuenta que en caso de incendio pueden desprenderse del producto sustancias tóxicas (gases, líquidos etc.) que pueden generar daños a la salud. Por eso, en caso de incendio deben usarse medidas adecuadas, como p. ej. máscaras antigás e indumentaria de protección.
7. Los productos con láser están provistos de indicaciones de advertencia normalizadas en función de la clase de láser del que se trate. Los rayos láser pueden provocar daños de tipo biológico a causa de las propiedades de su radiación y debido a su concentración extrema de potencia electromagnética. En caso de que un producto Rohde & Schwarz contenga un producto láser (p. ej. un lector de CD/DVD), no debe usarse ninguna otra configuración o función aparte de las descritas en la documentación del producto, a fin de evitar lesiones (p. ej. debidas a irradiación láser).
8. Clases de compatibilidad electromagnética (conforme a EN 55011 / CISPR 11; y en analogía con EN 55022 / CISPR 22, EN 55032 / CISPR 32)
 - Aparato de clase A:
Aparato adecuado para su uso en todos los entornos excepto en los residenciales y en aquellos conectados directamente a una red de distribución de baja tensión que suministra corriente a edificios residenciales.
Nota: Los aparatos de clase A están destinados al uso en entornos industriales. Estos aparatos pueden causar perturbaciones radioeléctricas en entornos residenciales debido a posibles perturbaciones guiadas o radiadas. En este caso, se le podrá solicitar al operador que tome las medidas adecuadas para eliminar estas perturbaciones.
 - Aparato de clase B:
Aparato adecuado para su uso en entornos residenciales, así como en aquellos conectados directamente a una red de distribución de baja tensión que suministra corriente a edificios residenciales.

Reparación y mantenimiento

1. El producto solamente debe ser abierto por personal especializado con autorización para ello. Antes de manipular el producto o abrirlo, es obligatorio desconectarlo de la tensión de alimentación, para evitar toda posibilidad de choque eléctrico.
2. El ajuste, el cambio de partes, el mantenimiento y la reparación deberán ser efectuadas solamente por electricistas autorizados por Rohde & Schwarz. Si se reponen partes con importancia para los aspectos de seguridad (p. ej. el enchufe, los transformadores o los fusibles), solamente podrán ser sustituidos por partes originales. Después de cada cambio de partes relevantes para la seguridad deberá realizarse un control de seguridad (control a primera vista, control del conductor de protección, medición de resistencia de aislamiento, medición de la corriente de fuga, control de funcionamiento). Con esto queda garantizada la seguridad del producto.

Instrucciones de seguridad elementales

Baterías y acumuladores o celdas

Si no se siguen (o se siguen de modo insuficiente) las indicaciones en cuanto a las baterías y acumuladores o celdas, pueden producirse explosiones, incendios y/o lesiones graves con posible consecuencia de muerte. El manejo de baterías y acumuladores con electrolitos alcalinos (p. ej. celdas de litio) debe seguir el estándar EN 62133.

1. No deben desmontarse, abrirse ni triturarse las celdas.
2. Las celdas o baterías no deben someterse a calor ni fuego. Debe evitarse el almacenamiento a la luz directa del sol. Las celdas y baterías deben mantenerse limpias y secas. Limpiar las conexiones sucias con un paño seco y limpio.
3. Las celdas o baterías no deben cortocircuitarse. Es peligroso almacenar las celdas o baterías en estuches o cajones en cuyo interior puedan cortocircuitarse por contacto recíproco o por contacto con otros materiales conductores. No deben extraerse las celdas o baterías de sus embalajes originales hasta el momento en que vayan a utilizarse.
4. Las celdas o baterías no deben someterse a impactos mecánicos fuertes indebidos.
5. En caso de falta de estanqueidad de una celda, el líquido vertido no debe entrar en contacto con la piel ni los ojos. Si se produce contacto, lavar con agua abundante la zona afectada y avisar a un médico.
6. En caso de cambio o recarga inadecuados, las celdas o baterías que contienen electrolitos alcalinos (p. ej. las celdas de litio) pueden explotar. Para garantizar la seguridad del producto, las celdas o baterías solo deben ser sustituidas por el tipo Rohde & Schwarz correspondiente (ver lista de recambios).
7. Las baterías y celdas deben reciclarse y no deben tirarse a la basura doméstica. Las baterías o acumuladores que contienen plomo, mercurio o cadmio deben tratarse como residuos especiales. Respete en esta relación las normas nacionales de eliminación y reciclaje.
8. En caso de devolver baterías de litio a las filiales de Rohde & Schwarz, debe cumplirse las normativas sobre los modos de transporte (IATA-DGR, código IMDG, ADR, RID).

Transporte

1. El producto puede tener un peso elevado. Por eso es necesario desplazarlo o transportarlo con precaución y, si es necesario, usando un sistema de elevación adecuado (p. ej. una carretilla elevadora), a fin de evitar lesiones en la espalda u otros daños personales.
2. Las asas instaladas en los productos sirven solamente de ayuda para el transporte del producto por personas. Por eso no está permitido utilizar las asas para la sujeción en o sobre medios de transporte como p. ej. grúas, carretillas elevadoras de horquilla, carros etc. Es responsabilidad suya fijar los productos de manera segura a los medios de transporte o elevación. Para evitar daños personales o daños en el producto, siga las instrucciones de seguridad del fabricante del medio de transporte o elevación utilizado.
3. Si se utiliza el producto dentro de un vehículo, recae de manera exclusiva en el conductor la responsabilidad de conducir el vehículo de manera segura y adecuada. El fabricante no asumirá ninguna responsabilidad por accidentes o colisiones. No utilice nunca el producto dentro de un vehículo en movimiento si esto pudiera distraer al conductor. Asegure el producto dentro del vehículo debidamente para evitar, en caso de un accidente, lesiones u otra clase de daños.

Instrucciones de seguridad elementales

Eliminación/protección del medio ambiente

1. Los dispositivos marcados contienen una batería o un acumulador que no se debe desechar con los residuos domésticos sin clasificar, sino que debe ser recogido por separado. La eliminación se debe efectuar exclusivamente a través de un punto de recogida apropiado o del servicio de atención al cliente de Rohde & Schwarz.
2. Los dispositivos eléctricos usados no se deben desechar con los residuos domésticos sin clasificar, sino que deben ser recogidos por separado.
Rohde & Schwarz GmbH & Co.KG ha elaborado un concepto de eliminación de residuos y asume plenamente los deberes de recogida y eliminación para los fabricantes dentro de la UE. Para desechar el producto de manera respetuosa con el medio ambiente, diríjase a su servicio de atención al cliente de Rohde & Schwarz.
3. Si se trabaja de manera mecánica y/o térmica cualquier producto o componente más allá del funcionamiento previsto, pueden liberarse sustancias peligrosas (p. ej. plomo, berilio o níquel). Por eso el producto solo debe ser desmontado por personal especializado con formación adecuada. Un desmontaje inadecuado puede ocasionar daños para la salud. Se deben tener en cuenta las directivas nacionales referentes a la eliminación de residuos.
4. En caso de que durante el trato del producto se formen sustancias peligrosas o combustibles que deban tratarse como residuos especiales (p. ej. refrigerantes o aceites de motor con intervalos de cambio definidos), deben tenerse en cuenta las indicaciones de seguridad del fabricante de dichas sustancias y las normas regionales de eliminación de residuos. Tenga en cuenta también en caso necesario las indicaciones de seguridad especiales contenidas en la documentación del producto. La eliminación incorrecta de sustancias peligrosas o combustibles puede causar daños a la salud o daños al medio ambiente.

Se puede encontrar más información sobre la protección del medio ambiente en la página web de Rohde & Schwarz.

Customer Support

Technical support – where and when you need it

For quick, expert help with any Rohde & Schwarz product, contact our customer support center. A team of highly qualified engineers provides support and works with you to find a solution to your query on any aspect of the operation, programming or applications of Rohde & Schwarz products.

Contact information

Contact our customer support center at www.rohde-schwarz.com/support, or follow this QR code:



QR code to the Rohde & Schwarz support page

Contents

1	Introduction.....	5
1.1	Feature Overview.....	5
1.2	Measurement Setup.....	5
1.3	The R&S TSME Option Concept.....	8
2	Preparing for Use.....	11
2.1	Unpacking and Setting Up the Instrument.....	12
2.2	Connecting the R&S TSME.....	15
2.3	Switching the Instrument On and Off.....	33
2.4	Connecting the R&S TSME to a Software Application for the First Time.....	34
2.5	Checking the Instrument.....	36
3	Front and Rear Panel Description.....	38
3.1	Front Panel.....	38
3.2	Rear Panel.....	38
4	Basic R&S TSME Functions.....	42
4.1	The R&S TSME Device Manager.....	42
4.2	Obtaining Device Information.....	44
4.3	Changing the IP Address for Multiple R&S TSME Configuration.....	45
4.4	Installing and Managing Software License Keys.....	46
4.5	Obtaining Firmware and Correction Data Updates.....	49
4.6	Configuring Measurement Bands.....	51
4.7	Aligning R&S TSME Manually.....	53
4.8	Interacting with R&S ROMES, R&S NESTOR, and R&S ViCom.....	53
5	Maintenance.....	57
6	Troubleshooting.....	59
6.1	Overview of Instrument Modes.....	59
6.2	Guide to Solving Instrument Connection Problems.....	61
6.3	Solving Other Miscellaneous Problems.....	64

Annex..... 66

A Available Cellular Bands..... 66

Index.....73

1 Introduction

1.1 Feature Overview

The R&S TSME ultra compact drive test scanner is a high-power platform for optimizing all conventional mobile radio networks. A highly sensitive 20 MHz front end for any input frequencies from 350 MHz to 4400 MHz, and an FPGA-based software-defined architecture offer unsurpassed performance while providing maximum flexibility and future-proofness.

- User-definable input frequency range from 350 MHz to 4400 MHz
- An RF and signal processing path with a bandwidth of 20 MHz
- Measurements on various mobile communication standards
- Support of automatic channel detection
- Support of MIMO measurement setups
- Support of position estimation of base stations together with R&S ROMES software (R&S ROMES option ROMES4LOC)
- Parallel measurements in GSM, WCDMA, TD-SCDMA, CDMA2000® 1xEV-DO, WiMAX™, LTE and TETRA networks
- ViCom programming interface for customer-specific applications (optional)
- Future-proof software-defined architecture
- Embedded high sensitivity GPS receiver

1.2 Measurement Setup

The R&S TSME is not a stand-alone drive test scanner; it requires a *host PC* connected via LAN and some additional equipment in order to perform measurements.



Figure 1-1: Typical measurement setup with the R&S TSME



Important requirements for host PC

In order to control and perform measurements with the R&S TSME, a host PC or notebook with LAN interface is required (not included in the package), with the following **minimum configuration**:

- Intel Quad-Core i7
- 4 GB Memory
- Windows 7
- **Dedicated Gbit LAN adapter with Jumbo Frames (9 kB) and Flow Control enabled**

It is important for the host PC to have its own **dedicated LAN adapter** for the connection to one or more R&S TSMEs only, and is not integrated in a regular office network.

There are different possibilities for the host PC to control the R&S TSME:

- Using the drive test software platform R&S ROMES or R&S NESTOR (not part of this package!)
- Using the R&S ViCom programming interface package and integrating the R&S TSME as an OEM product into a customer-specific software application (not part of this package!)

The host PC is required for the following tasks:

- Obtaining hardware and firmware information on the R&S TSME (via the R&S TSME Device Manager, see [Chapter 4.2, "Obtaining Device Information"](#), on page 44)

- Configuring the R&S TSME (via the R&S TSME Device Manager, see [Chapter 4.1, "The R&S TSME Device Manager"](#), on page 42)
- Sending the measurement commands (via the drive test software), thus controlling and performing the actual measurement
- Updating the R&S TSME firmware when required (see ["Automatic firmware updates"](#) on page 54)

In addition to the host PC, the following further equipment is required to perform measurements with the R&S TSME:



For an overview of the package contents for the R&S TSME refer to ["Accessory list"](#) on page 12 and to the Release Notes.

Table 1-1: Equipment required to perform measurements with the R&S TSME

Equipment	Availability
Antennas	<ul style="list-style-type: none"> • GPS: active antenna with cable and SMA connector included in package • RF antenna and cable (not included) • Optionally: R&S TSME accessory antennas (See the product page on the Rohde & Schwarz website at: https://www.rohde-schwarz.com/product/TSME > "Options")
Connection cables	<ul style="list-style-type: none"> • DC power supply cable with a cigarette lighter connector (included in package) • Optionally, 4-fold DC y-cable (R&S TSME-ZYC4) to run 4 R&S TSMEs from one AC power supply (e.g. R&S TSMW-Z1) • LAN cable to connect host PC (RJ45 Patch cable CAT6 2m, included in package) • Synchronization cable to synchronize multiple R&S TSMEs <ul style="list-style-type: none"> – option R&S TSME-ZC2 - Synchronization cable for 2 R&S TSMEs (order no. 1522.6560.02) – option R&S TSME-ZC4 - Synchronization cable for 4 R&S TSMEs (order no. 1522.6831.02)
AC power supply	Optionally included in package: R&S TSME-Z1 (order number 1514.6913.02)
World-wide adapter for earthing type plug	Included in R&S TSME-Z1 option, required to use the R&S TSME-Z1 world wide
LAN switch	Optionally, 5-port Gbps LAN switch with 9k jumbo frame support, AC or USB powered, to connect 4 R&S TSMEs to one host PC (For example: R&S TSPC-LS Gbit LAN Switch - USB powered, order no. 3624.8364.02)
USB to LAN Adapter	Optionally, USB 3.0 To Gbit LAN Adapter (R&S TSPC-U2L, order no. 3593.8430.02), provides an additional LAN port on the host PC to connect two R&S TSMEs to one host PC
Mechanical connections for multiple R&S TSMEs	Metal brackets and screws included in option R&S TSME-ZC2 - Synchronization cable for 2 R&S TSMEs option R&S TSME-ZC4 - Synchronization cable for 4 R&S TSMEs
Required software options	Installed at the factory Additional software options can be installed subsequently via the R&S TSME Device Manager (for details refer to Chapter 4.6, "Configuring Measurement Bands" , on page 51).

Equipment	Availability
R&S ROMES or R&S NES-TOR measurement software with appropriate technology option(s)	Not included in package
or: R&S ViCom Interface package for customer software	Not Included in package

1.3 The R&S TSME Option Concept

The R&S TSME scanner consists of the R&S TSME hardware as well as a set of (specified) technology and band options when it comes from the factory.

1.3.1 Technology Options

Technology options allow for the R&S TSME to scan the input based on a specific technology, for example, LTE. All technology options can be installed on the same instrument; the R&S TSME can measure various technologies simultaneously.

Following technology options are available (for current availabilities see <http://www2.rohde-schwarz.com/product/TSME.html>):

Table 1-2: Available R&S TSME technology options

Options	Order number	Description
R&S TSME-K21	1514.6820.02	R&S TSME scanner option: WCDMA
R&S TSME-K22	1514.6836.02	R&S TSME scanner option: CDMA2000
R&S TSME-K23	1510.0085.02	R&S TSME scanner option: GSM
R&S TSME-K24	1510.0010.02	R&S TSME scanner option: EVDO
R&S TSME-K25	1522.6954.02	R&S TSME scanner option: CW
R&S TSME-K26	1514.6920.02	R&S TSME scanner option: TETRA
R&S TSME-K27	1514.6813.02	R&S TSME scanner option: RF-Power Scan
R&S TSME-K28	1514.6842.02	R&S TSME scanner option: WiMAX
R&S TSME-K29	1514.6859.02	R&S TSME scanner option: LTE
R&S TSME-K30	1514.6871.02	R&S TSME scanner option: LTE MIMO
R&S TSME-K32	1522.6960.02	R&S TSME scanner option: LTE eMBMS
R&S TSME-K34	1522.6731.02	R&S TSME scanner option: NB-IoT/Cat NB1-Scanning
R&S TSME-K40	1514.7232.02	R&S TSME Automatic Channel Detection



Ordering software options

When you order a software option you must supply the serial number of the R&S TSME. License keys are shipped as a printed "License Keys List". Advance deliveries may consist of a PDF file. Unregistered software licenses can be downloaded from the Rohde & Schwarz website (<https://extranet.rohde-schwarz.com/service>).

For details see the "R&S TSME-Kx Software Options Installation Manual".

1.3.2 Band Options

The band options have been introduced as a new concept to provide a more cost efficient scanner configuration when only a limited number of bands need to be measured. Using these options, the measurement bandwidth of the R&S TSME is limited to a number of cellular network bands (uplink and downlink). The bands can be freely selected by the user. Band options are independent from the technology options: a licensed technology can be measured in all licensed bands (uplink and downlink).

Alternatively, a R&S TSME band option is provided which can measure the full bandwidth. With this option the scanner can measure in the complete bandwidth from 350 MHz to 4.4 GHz without limitations. All installed technologies can be measured in this bandwidth at the same time.

Example:

For example, an R&S TSME with the technology options R&S TSME-K21 (WCDMA) and R&S TSME-K23 (GSM), as well as the band option R&S TSME-K2B (2 bands measured simultaneously), can scan for GSM and WCDMA signals in two bands (e.g. 900 MHz and 1800 MHz) at the same time.

Upgrade options are available to increase the bandwidth of the R&S TSME from a limited number of bands to full bandwidth.

Following band options are available:

Table 1-3: Available R&S TSME band options

Options	Order number	Description
R&S TSME-KAB	1514.7384.02	All bands measured simultaneously
R&S TSME-K1B	1514.7403.02	1 band measured simultaneously
R&S TSME-K2B	1514.7410.02	2 bands measured simultaneously
R&S TSME-K3B	1514.7426.02	3 bands measured simultaneously
R&S TSME-K4B	1514.7432.02	4 bands measured simultaneously
R&S TSME-K5B	1514.7449.02	5 bands measured simultaneously
R&S TSME-KUB	1514.7390.02	Upgrade: 1 additional band measured simultaneously

The R&S TSME band assignment can be reconfigured by the user (see [Chapter 4.6, "Configuring Measurement Bands"](#), on page 51).

For an overview of available cellular bands and their characteristics see [Chapter A, "Available Cellular Bands"](#), on page 66.

2 Preparing for Use

WARNING

Risk of injury due to disregarding safety information

Observe the information on appropriate operating conditions provided in the data sheet to prevent personal injury or damage to the instrument. Read and observe the basic safety instructions provided with the instrument, in addition to the safety instructions in the following sections. In particular:

- Do not use an isolating transformer to connect the instrument to the AC power supply.
- Do not open the instrument casing.

NOTICE

Risk of instrument damage during operation

An unsuitable operating site or test setup can cause damage to the instrument and to connected devices. Ensure the following operating conditions before you switch on the instrument:

- The instrument is dry and shows no sign of condensation.
- The instrument is positioned as described in the following sections.
- Signal levels at the input connectors are all within the specified ranges.

NOTICE

Instrument damage caused by electrostatic discharge

Electrostatic discharge (ESD) can damage the electronic components of the instrument and the device under test (DUT). Electrostatic discharge is most likely to occur when you connect or disconnect a DUT or test fixture to the instrument's test ports. To prevent electrostatic discharge, use a wrist strap and cord and connect yourself to the ground, or use a conductive floor mat and heel strap combination.



EMI suppression

Electromagnetic interference (EMI) may affect the measurement results.

To suppress generated electromagnetic interference (EMI):

- Use suitable shielded cables of high quality. For example, use double-shielded RF and LAN cables.
- Always terminate open cable ends.
- Note the EMC classification in the data sheet.
- Use the supplied DC cable or a DC cable shorter than 3 m.
- DC-based lab networks are not allowed to be used for power supply.
- Operate the instrument only with an **active** antenna connected to the [GPS ANT] connector.

2.1 Unpacking and Setting Up the Instrument

The following section describes how to set up the instrument.

NOTICE

Risk of instrument damage due to inappropriate operating conditions

Specific operating conditions are required to ensure accurate measurements and to avoid damage to the instrument. Observe the information on appropriate operating conditions provided in the basic safety instructions and the instrument's data sheet.

Check the equipment for completeness using the delivery note and the accessory lists for the various items. Check the instrument for any damage. If there is damage, immediately contact the carrier who delivered the instrument. Make sure not to discard the box and packing material.



Packing material

Retain the original packing material. If the instrument needs to be transported or shipped later, you can use the material to protect the control elements and connectors.

Accessory list

The following items are included with shipment of the R&S TSME:

- DC power supply cable with a cigarette lighter connector
- LAN cable to connect host PC (RJ45 Patch cable CAT6 2m)
- Active GPS antenna
- CD-ROM with required R&S TSME software, drivers, tools, and manual

Rackmounting

The R&S TSME can be installed in a 19 inch rack using a rack adapter kit for one or two R&S TSMEs (option R&S TSME-Z2, 1522.6502.02). The installation instructions are part of the adapter kit.



Figure 2-1: R&S TSME mounted in a rack (option R&S TSME-Z2)

Other mounting options

A stack of R&S TSMEs can be mounted to a metal base using the option R&S TSME-Z4 (1522.6590.02). How to connect the individual R&S TSMEs is described in [Chapter 2.2.5.4, "Connecting Multiple R&S TSMEs with Each Other"](#), on page 25.

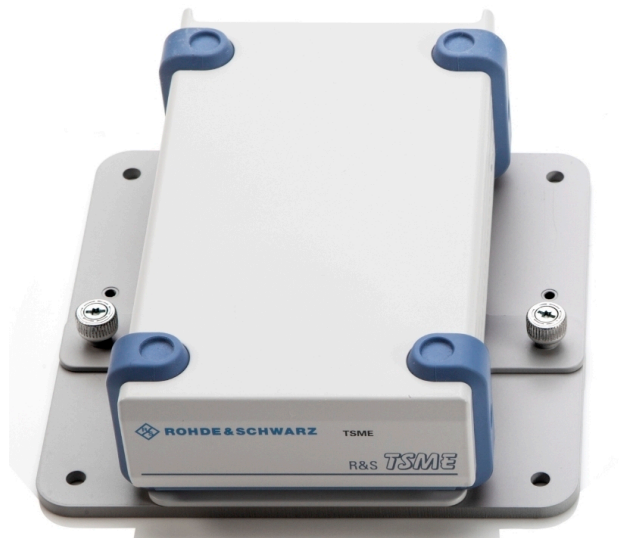

Figure 2-2: R&S TSME mounted to a metal base (option R&S TSME-Z4)

Alternatively, the R&S TSME can be packed in a backpack system (R&S TSME-Z3, order no. 1514.6936.02, see the corresponding "Getting Started" manual).



Figure 2-3: R&S TSME packed in a backpack system (option R&S TSME-Z3)

NOTICE

Risk of instrument damage due to overheating

An insufficient airflow can cause the instrument to overheat, which may disturb the operation and even cause damage.

Make sure that all fan openings are unobstructed and that the airflow perforations are unimpeded, particularly when the instrument is installed in a rack or packed in a backpack. The R&S TSME draws in fresh air from the bottom and warm air flows out at its sides.

Thus, if no active cooling is installed, ensure that the following surrounding spaces to the instrument are kept clear:

- Bottom side: minimum 1 cm
- Left/right sides: minimum 2 cm

In very warm environments, do not stack instruments - place them side by side so that each instrument can draw sufficiently cool air.

2.2 Connecting the R&S TSME

This section describes how to connect the R&S TSME to the other devices in the measurement setup (see also [Chapter 1.2, "Measurement Setup"](#), on page 5).

- [Connecting the DC Power Supply](#).....15
- [Setting Up the LAN Connection to the Host PC](#).....16
- [Connecting External Devices](#).....21
- [Connecting a Kensington Lock](#).....22
- [Connecting Multiple R&S TSMEs to one Host PC \(LTE MIMO Setups, Parallel Usage\)](#).....22

2.2.1 Connecting the DC Power Supply

The DC power supply connector is on the rear panel of the unit. Voltages from 10 V to 27 V are supported. There is no need to set the used voltage manually.

Possible power cable connections

The R&S TSME can work with the following DC power supplies:

- Cigarette lighter power supply (for example in a vehicle) using the supplied DC power cable
- Optional AC power supply and power cable R&S TSME-Z1 (see [Table 1-1](#))
- Proprietary power supply with an adapted power cable

Using the supplied cigarette lighter power supply cable

- ▶ To use the power supply from a cigarette lighter, connect the supplied power cable from the R&S TSME to the cigarette lighter.

Connecting a proprietary power supply

- ▶ To use a proprietary DC supply with the R&S TSME power cable, demount the cigarette lighter adapter from the supplied power cable and connect the open ends of the cable to the proprietary power supply. Be sure to respect the correct polarity (see [Figure 2-4](#)).

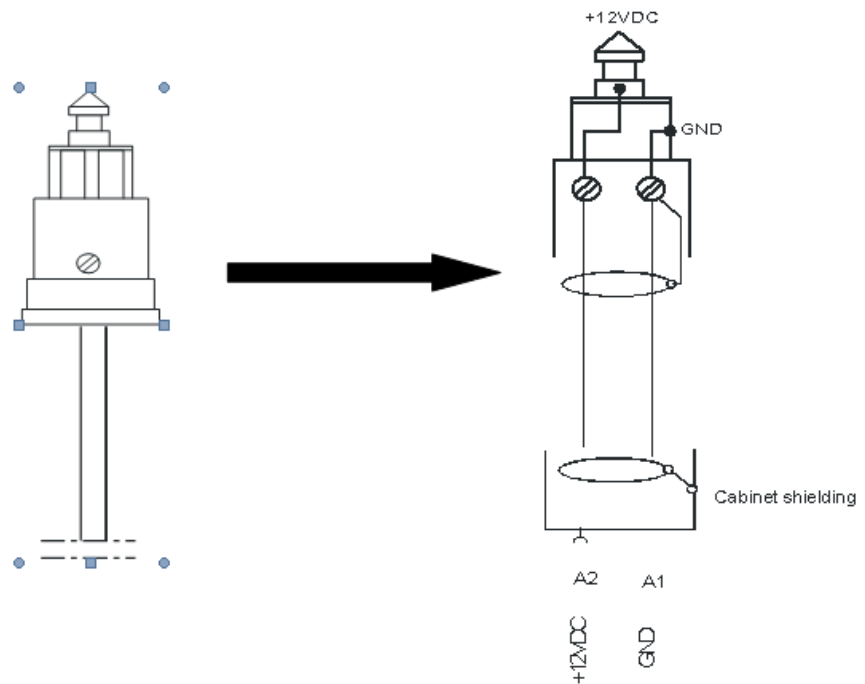

Figure 2-4: Supplied power cable with cigarette lighter adapter

⚠ DANGER

Danger of shock!

To avoid a shock hazard and instrument damage, note the following:

- After moisture condensation, allow the instrument to dry before switching on.
- The instrument is still power-supplied while it is in standby mode, that is, with the power button switched off, but still connected with the DC power supply.
- After connecting the power supply the instrument is immediately under power.
- The supplied DC connector is intended for disconnection.
- If any DC supply other than R&S TSME-Z1 is used:
 - The DC supply must be in accordance with IEC / EN / UL / CSA 60950-1 or IEC / EN / UL / CSA EN EN61010-1.
 - Use only Safety Extra Low Voltage (SELV) power supplies
 - Observe the DC input range of 10 V to 27 V with maximum of 1.8 A (inrush current)
 - The 12 V vehicle cigarette lighter socket must be fused

2.2.2 Setting Up the LAN Connection to the Host PC

As mentioned in [Chapter 1.2, "Measurement Setup"](#), on page 5, a host PC or notebook with LAN interface is required to control and perform measurements with the R&S TSME.

The R&S TSME is equipped with a network interface and can be connected to an Ethernet LAN (local area network). The interface can be used to connect the R&S TSME to a host PC.



How to connect multiple R&S TSMEs to a single host PC (for example for LTE MIMO setups) is described in [Chapter 2.2.5, "Connecting Multiple R&S TSMEs to one Host PC \(LTE MIMO Setups, Parallel Usage\)"](#), on page 22.

The following scenarios are possible.

- Connection between PC and R&S TSME(s) using static IP addresses.
- Connection between PC and R&S TSME(s) using dynamical generated IP addresses (**Auto-IP**).

Operating Modes



The "Full auto-IP" operating mode is only available with following versions of ROMES, ViCom and NESTOR software.

- R&S ROMES: Version 18.1 and later
- R&S ViCOM: Version 16.20 and later
- R&S NESTOR: Version 2.7.0 and later

- **"Full auto-IP" operating mode**

IP addresses are automatically generated on PC and R&S TSME(s) if the following conditions are met:

- PC network interface is configured to obtain an IP address automatically
- IP address stored in R&S TSME(s) is not in range 169.254.0.1 – 169.254.255.254 (inclusive).

Note: This is the IP address set by the R&S TSME Device Manager.

- **"Partial auto-IP" operating mode**

IP address is automatically generated on PC and a static IP address is used on R&S TSME if the following conditions are met:

- PC network interface is configured to obtain an IP address automatically
- IP address stored in R&S TSME is in range 169.254.0.1 – 169.254.255.254 (inclusive).

Note: This is the IP address set by the R&S TSME Device Manager.

- **"Static IP" operating mode**

IP address is manually set on PC and a static IP used on R&S TSME if the following conditions are met:

- PC LAN interface is configured to use a user-defined IP address, not in range 169.254.0.1 – 169.254.255.254 (inclusive).

Recommendations/Limitations of Operating Modes

- **"Full auto-IP" operating mode**

- Only 1 PC and 1 or more R&S TSME devices per LAN interface, either connected directly or via a L2 switch. (This operating mode shall not be used when

more than 1 PC is physically connected to the same subnetwork, e.g. via the switch.)

- PC's LAN interface shall not receive an IP from a DHCP server. (The IP address generated for PC shall be matching following pattern: 169.254.X.Y.)
- All R&S TSME devices on the same LAN interface shall be configured with stored IP addresses not in the range 169.254.1.0 – 169.254.254.255 (inclusive) to prevent conflicts.

Note: R&S TSME devices with stored IP addresses in ranges 169.254.0.1 – 169.254.0.255 (inclusive) or 169.254.255.0 – 169.254.255.254 (inclusive) are effectively operating in "partial auto-IP" operating mode.
- Depending on software accessing the R&S TSME devices, it may be mandatory to configure the stored IP addresses in all R&S TSME devices to be unique.

Example: R&S TSME Device Manager does not have this requirement, R&S ROMES / R&S Nestor may have such requirements depending on the use made internally of the stored IP address as unique identifier.
- **"Partial auto-IP" operating mode**

This mode shall only be used for specific cases, "full auto-IP" or "static IP" operating modes shall be preferred.

 - 1 or more PCs and 1 or more R&S TSME devices per LAN interface, either connected directly or via a L2 switch
 - Each of the PC's LAN interface physically connected to the sub network shall not receive an IP from a DHCP server. (The IP address generated for PC shall be matching following pattern: 169.254.X.Y.)
 - All R&S TSME devices on the same LAN interface shall be configured with stored IP addresses in the ranges 169.254.0.1 – 169.254.0.255 (inclusive) or 169.254.255.0 – 169.254.255.254 (inclusive), and use unique IP addresses. These ranges are important to prevent conflicts with IP addresses dynamically generated for the PC LAN interfaces.

Note: If a R&S TSME is shared with 2 or more PCs, and its stored IP address is not in the defined range above, this may lead in rare cases to IP conflicts. It is therefore recommended to respect this rule.
- **"Static IP" operating mode**
 - 1 or more PCs and 1 or more R&S TSME(s), either connected directly or via a L2 switch.
 - Other network devices are permitted, as long as all IP addresses used are unique.

This section describes how to configure the LAN interface for a single R&S TSME. It includes the following topics:

- [Configuring the LAN Interface on the Host PC](#)..... 19
- [Connecting the R&S TSME to the Host PC](#)..... 21

2.2.2.1 Configuring the LAN Interface on the Host PC

Each R&S TSME has the default IP address **192.168.0.2**. It is recommended that you define the fixed IP address **192.168.0.1** to the host PC.

To control the R&S TSME from the host PC, the LAN interface of the host PC must be configured as follows:

1. Press the "Windows" key or the [CTRL + ESC] key combination on your keyboard to access the Windows "Start" menu.
2. Select "Control Panel > Network and Internet > Network and Sharing Center".
3. Select "Change adapter settings".
4. Double-click the LAN interface with which the R&S TSME is connected.
The items used by the LAN connection are displayed.
5. Select the entry named "Internet Protocol Version 4 (TCP/IPv4)".

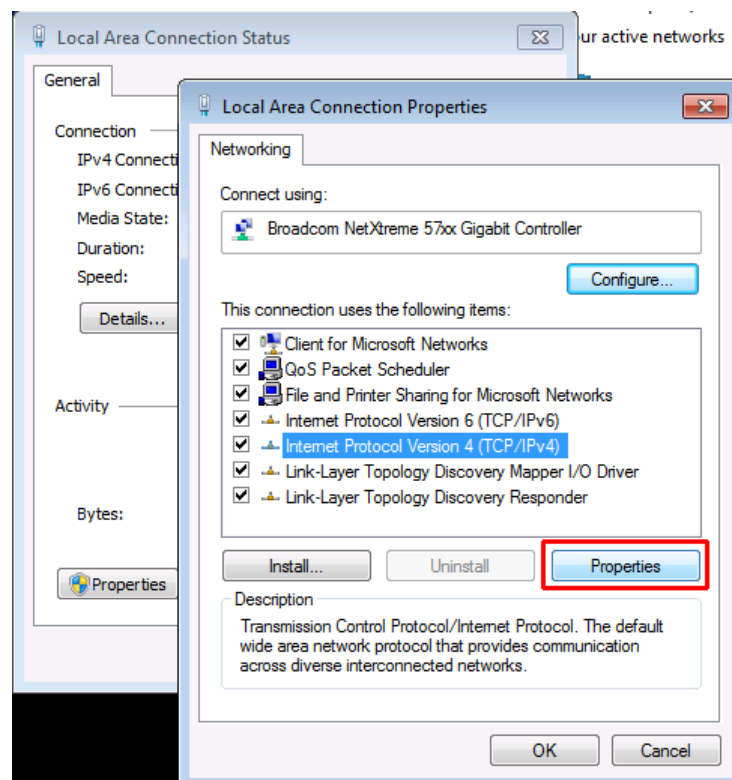

6. Select the "Properties" button.
7. Configure the following TCP/IP settings:
 - Select "Use the following IP address" (fixed IP, not dynamic)
 - IP address: **192.168.0.1** (recommended)
 - Subnet mask: 255.255.255.0
 - No Default Gateway

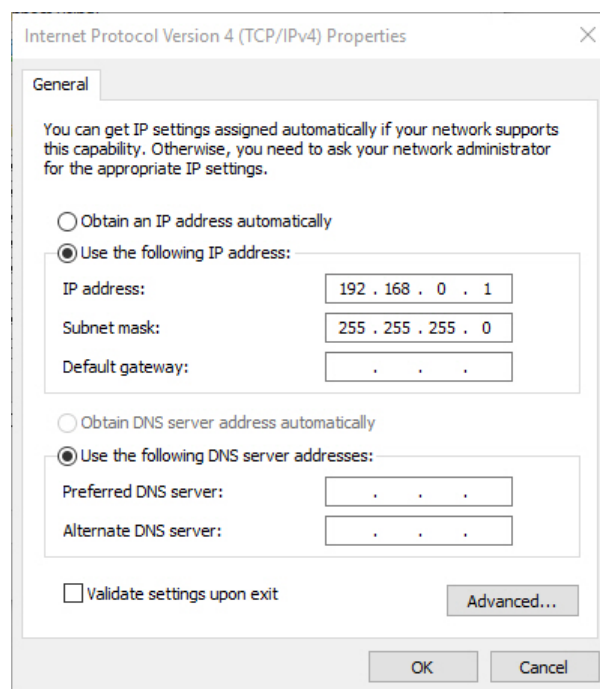

8. Enable the use of 9-kB-jumbo frames:
 - a) Return to the "Local Area Connection Properties" dialog box.
 - b) Select the entry for the LAN adapter and then "Properties".
 - c) Switch to the "Advanced" tab.

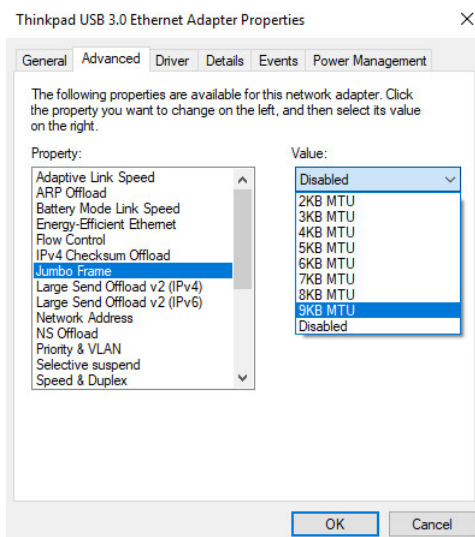

- d) Select the "Jumbo Frames" property and the "Value": "9014 Bytes".
Note: this setting may cause problems in Windows, but it is an important prerequisite for correct operation of the R&S TSME. See [Chapter 6.2, "Guide to Solving Instrument Connection Problems"](#), on page 61 for help.

9. Close the Control Panel, reboot the host PC and check if the connection can be established successfully (see [Chapter 6, "Troubleshooting"](#), on page 59).



Activating required ports

If your firewall is active make sure the following ports are available:

- Port 17476: Data transport between PC and R&S TSME

2.2.2.2 Connecting the R&S TSME to the Host PC

The R&S TSME has a built-in 1000BASE-T, (802.3ab) 1 Gbit/s Ethernet interface. The host PC must have a separate 1 Gbit network interface card with an independent LAN connection and a deactivated firewall.



Dedicated LAN adapter and IP address for host PC

It is important for the host PC to have its own dedicated LAN adapter for the connection to one or more R&S TSMEs (or a switch), rather than being integrated in a regular office network.

If multiple R&S TSMEs are connected to one host PC, following rules are valid.

- Using "static IP" or "partial auto-IP" operating mode, it is important to define unique IP addresses for each instrument using the R&S TSME Device Manager (see R&S TSME User Manual, chapter Configuring the R&S TSME).
- Using "full auto-IP" operating mode, it is recommended to define unique IP addresses for each instrument, but depending on software run, it may not be mandatory.

- ▶ Connect the supplied LAN cable to the LAN connector on the rear panel of the R&S TSME, and to the host PC.

Windows 10 automatically detects the network connection and all devices in the same subnet when the R&S TSME is switched on.

2.2.3 Connecting External Devices

The following external devices are required for standard operation (see also [Chapter 1.2, "Measurement Setup"](#), on page 5):

- Connect the instrument to the power supply as described in [Chapter 2.2.1, "Connecting the DC Power Supply"](#), on page 15.
- Connect the PC or notebook LAN port to the LAN port of the R&S TSME as described in [Chapter 2.2.2, "Setting Up the LAN Connection to the Host PC"](#), on page 16.
- Connect the (optional) antenna's SMA-connector to the RF IN connector.
- Connect the GPS antenna to the GPS ANT connector of the instrument for time synchronization to a GPS signal (3V, max.100 mA for active antenna). To ensure time synchronization of the R&S TSME, it is required to have a GPS antenna con-

ected. A missing GPS antenna will lead over time to the point that signals cannot be detected anymore.



The SMA connector is sensitive to mechanical stress. Use the following handling precautions.

- Always use a torque wrench and mount the cable end with 60 Ncm.
- Do not stack adapters directly at the SMA connector. If you need to use adapters (e.g: SMA to N), then always use a specific adapter cable (R&S no. 4900.1700.00).

NOTICE

Risk of instrument damage

Do not overload the input power at the RF input connector, otherwise the input stage could be severely damaged. For maximum allowed values, see the data sheet.

2.2.4 Connecting a Kensington Lock

The R&S TSME provides a connector for a Kensington lock, which can be used to secure a mobile device against theft. The connector is on the side panel of the instrument.



Figure 2-5: Connector for a Kensington lock on the R&S TSME

2.2.5 Connecting Multiple R&S TSMEs to one Host PC (LTE MIMO Setups, Parallel Usage)

In some cases it is useful to connect more than one R&S TSME to the same host PC. In particular, the following measurement scenarios require this setup:

- LTE MIMO setups
- Using two R&S TSMEs in parallel



Due to the compatibility of R&S TSME and R&S TSME6, the combined usage of R&S TSME and R&S TSME6 devices in an LTE-MIMO setup is possible.

2.2.5.1 Using Two R&S TSMEs in Parallel

Using two R&S TSMEs in parallel enhances the measurement capability compared to a single R&S TSME, and can increase measurement speed.

A R&S TSME intelligently captures signals of multiple technologies at the same time, if they fall within its 20 MHz frontend.

If two R&S TSMEs are connected, and a technology option is installed on at least one of the R&S TSMEs, the measurement software can perform measurements on both R&S TSME frontends. Thus you can create a virtual 40 MHz frontend.

Therefore, performing measurements on combined R&S TSMEs is faster than performing them on separate R&S TSMEs in shared spectrum networks.

Using two R&S TSMEs in parallel requires the following options:

- A band option (R&S TSME-KxB) on each R&S TSME
- Identical technology options on both R&S TSMEs to perform measurements on both R&S TSME frontends simultaneously

The following table demonstrates some sample configurations and applications for parallel usage

Table 2-1: Sample configurations and applications for parallel usage

Configuration		R&S TSME 1	R&S TSME 2	Application
Config 1	Options	GSM, KAB	KAB	Increase measurement speed
	Measurements	GSM	GSM	
Config 2	Options	LTE, KAB	WCDMA, GSM, KAB	Use scanners separately; join for increased speed
	Measurements	GSM, WCDMA, LTE	GSM, WCDMA, LTE	
Config 3	Options	LTE, MIMO, KAB	LTE, KAB	Use scanners separately; join for LTE MIMO measurement
	Measurements	LTE, MIMO	LTE, MIMO	

2.2.5.2 LTE MIMO Setups with Two R&S TSMEs

Basic LTE MIMO measurements are possible with a single R&S TSME, which can analyze two different transmission paths of a signal from two different transmit antennas. A single R&S TSME can determine the RSRP/Q and RS SINR results for both paths (see documentation of the measurement software for details).

If two R&S TSMEs are connected to one host PC, multiple signals can be received by two receive antennas and processed in one application. This is useful, for example, to

analyze a MIMO matrix, condition numbers, or ranks, or generally to optimize the LTE MIMO setup.

Required options

An LTE MIMO measurement setup with two R&S TSMEs requires the following options:

- LTE option (R&S TSME-K29) and a band option (R&S TSME-KxB) installed on at least one R&S TSME in the MIMO setup
- LTE MIMO option (R&S TSME-K30) installed on at least one R&S TSME in the MIMO setup
- MIMO extension option R&S TSME-K300, which is installed at factory by default, on each R&S TSME

The following table demonstrates the minimum configuration for LTE MIMO measurements.

Table 2-2: Sample (minimum) configuration for LTE MIMO measurements with 2 R&S TSMEs

R&S TSME	Option
1	KxB, LTE (K29), LTE MIMO (K30)
2	none (MIMO extension option R&S TSME-K300 installed by default)

Furthermore, the following connections are required for an LTE MIMO setup:

- Power supply for each R&S TSME, see [Chapter 2.2.1, "Connecting the DC Power Supply"](#), on page 15
The R&S TSME-ZYC option provides a cable to connect 2 R&S TSMEs to one power source
- Synchronization and mechanical connection of two R&S TSMEs using the R&S TSME-ZC2 option (mandatory)
- LAN connection between the two R&S TSMEs and the host PC, see [Chapter 2.2.5.5, "Configuring the LAN Connections Between Multiple R&S TSMEs Connected to One Host PC"](#), on page 28

2.2.5.3 LTE MIMO Setups with Four R&S TSMEs

If four R&S TSMEs are connected to one host PC, multiple signals can be received by four receive antennas and processed in one application. This is useful, for example, to perform LTE MIMO path measurements or throughput/CQI estimations (in addition to the results using 2 R&S TSMEs).

Required options

An LTE MIMO measurement setup with four R&S TSMEs requires the following options:

- One R&S TSME with an installed LTE option (R&S TSME-K29) and a band option (R&S TSME-KxB)
- One R&S TSME with an installed LTE MIMO option (R&S TSME-K30)

- All R&S TSMEs must have the MIMO extension option R&S TSME-K300, which is installed at factory by default

Table 2-3: Sample (minimum) configuration for LTE MIMO measurements with 4 R&S TSMEs

R&S TSME	Option
1	KxB, LTE (K29), LTE MIMO (K30)
2	none (MIMO extension option R&S TSME-K300 installed by default)
3	none (MIMO extension option R&S TSME-K300 installed by default)
4	none (MIMO extension option R&S TSME-K300 installed by default)

In addition, the following connections are required for an LTE MIMO setup with four R&S TSMEs:

- Power supply for each R&S TSME, see [Chapter 2.2.1, "Connecting the DC Power Supply"](#), on page 15
The R&S TSME-ZYC4 option provides a cable to connect four R&S TSMEs to one power source, such as the R&S TSMW-Z1 AC power supply
- Synchronization and mechanical connection of four R&S TSMEs using the R&S TSME-ZC4 option (mandatory)
- LAN connection between the four R&S TSMEs and the host PC, see [Chapter 2.2.5.5, "Configuring the LAN Connections Between Multiple R&S TSMEs Connected to One Host PC"](#), on page 28

2.2.5.4 Connecting Multiple R&S TSMEs with Each Other

For setups with multiple R&S TSMEs, the devices must be connected with each other mechanically, and also to a common synchronization cable.

For **2x2 setups**, the option R&S TSME-ZC2 is required. It consists of a metal mounting bracket with screws and a synchronization cable with 2 connectors.

For **4x4 setups**, the option R&S TSME-ZC4 is required. It contains three metal mounting brackets with screws and a synchronization cable with 4 connectors.

To connect the devices using the metal mounting brackets

1. Turn the first device upside down.
2. Place the mounting bracket on top of the device, with the hole over the airflow perforations and the brackets facing upwards.
3. Screw the metal plate to the bottom of the device using the supplied screws.



4. Turn the device with the connected bracket right side up.
5. Slide the bracket over the top of the second device.
6. Fasten the four screws of the bracket to the side panels of the second device using the supplied screws.



7. To connect a third and fourth R&S TSME, repeat these steps.
8. When all R&S TSMEs have been connected with the metal brackets, connect the synchronization cable to the AUX port on each device.



Figure 2-6: R&S TSME LTE MIMO 4x4 setup with synchronization cable



Further connections for setups with multiple R&S TSMEs

- Connect all R&S TSMEs to a power supply. Optionally, all devices can be connected to the same power supply.
The R&S TSME-ZYC option provides a cable to connect 2 R&S TSMEs to one power source
The R&S TSME-ZYC4 option provides a cable to connect four R&S TSMEs to one power source, such as the R&S TSMW-Z1 AC power supply.
- Connect an RF antenna (not included in package) to the R&S TSME.
- You only have to connect a GPS antenna to one of the connected R&S TSMEs. It is recommended that you connect it to the R&S TSME with the lowest IP address.
- Configure the LAN connection to the host PC as described in the following chapter.

2.2.5.5 Configuring the LAN Connections Between Multiple R&S TSMEs Connected to One Host PC

The LAN connection from multiple R&S TSMEs to the same host PC can be implemented using two different methods:

- Using separate network interface connectors (NICs)

This allows for optimum data rates since each scanner can use the full Gbit LAN bandwidth to the host PC

- Using a switch
This allows for simple connection and less wiring

Using separate network interface connectors (NICs)

The following graphic illustrates the setup for two R&S TSMEs connected to the same host PC in parallel, using a dual NIC adapter on the PC and a synchronization cable between the R&S TSMEs (AUX ports).

The optional USB 3.0 To Gbit LAN Adapter R&S TSPC-U2L provides an additional port on the host PC.

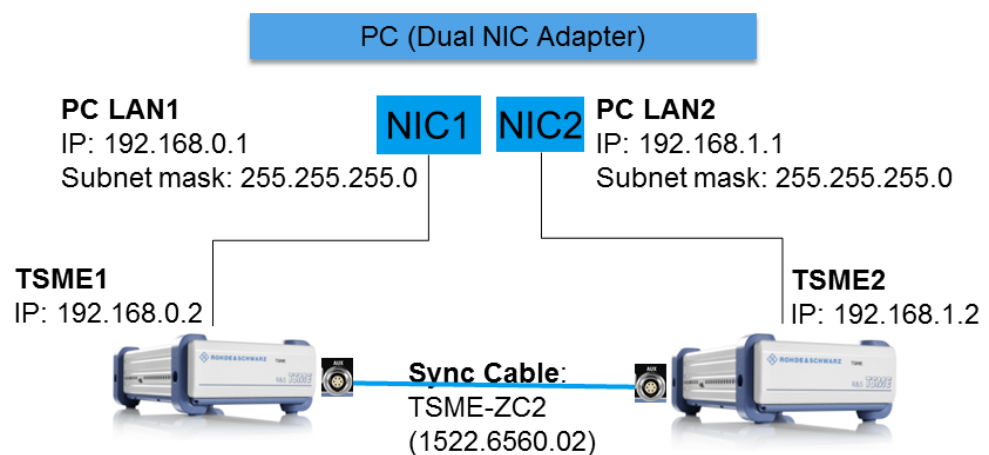

Figure 2-7: Configuration for parallel R&S TSME usage using separate network interface connectors

Each pair of R&S TSME and network interface connector is configured to be in a separate subnet.

To configure two R&S TSMEs connected to one host PC using different NICs

1. To configure the network settings for both R&S TSMEs, set up the first LAN interface on the PC to use the following network settings, as described in [Chapter 2.2.2.1, "Configuring the LAN Interface on the Host PC"](#), on page 19:
 - **IP address:** 192.168.0.1
 - **Subnet mask:** 255.255.255.0
2. Change the IP addresses of the R&S TSMEs so they are located in different subnets, as described in [Chapter 4.3, "Changing the IP Address for Multiple R&S TSME Configuration"](#), on page 45.
 - a) Start the R&S TSME Device Manager.
 - b) Connect the first R&S TSME to the PC.
 - c) Define the IP address: 192.168.0.2 (default).
 - d) Connect the second R&S TSME to the PC.
 - e) Define the IP address: 192.168.1.2.

- f) Close the R&S TSME Device Manager.
3. Move the connector from the second R&S TSME to the second LAN adapter.
4. Configure the LAN interfaces on the PC so they are located in the same subnets as the R&S TSMEs, using the following network settings, as described in [Chapter 2.2.2.1, "Configuring the LAN Interface on the Host PC"](#), on page 19:

LAN1: (already configured in [step 1](#))

- **IP address:** 192.168.0.1
- **Subnet mask:** 255.255.255.0

LAN2:

- **IP address:** 192.168.1.1
- **Subnet mask:** 255.255.255.0

5. Check the IP connections in the R&S TSME Device Manager.

All connected and switched on R&S TSMEs should be displayed.
(If not, see [Chapter 6, "Troubleshooting"](#), on page 59.)

Using a switch

The following graphic illustrates the setup for two R&S TSMEs connected to the same host PC in parallel, using a switch between the PC and the R&S TSMEs, and a synchronization cable between the R&S TSMEs (AUX ports). The setup for four R&S TSMEs is shown in [Figure 2-9](#).



The optional 5-port Gbit LAN Switch - USB powered R&S TSPC-LS allows you to connect four R&S TSMEs to the same host.



Prerequisites for the switch

When using a switch to connect multiple R&S TSMEs to one host PC, the following conditions apply:

- 1 GBit LAN switch
 - 9K Jumbo frame support
 - Dedicated LAN adapter on the host PC to connect the switch to
-

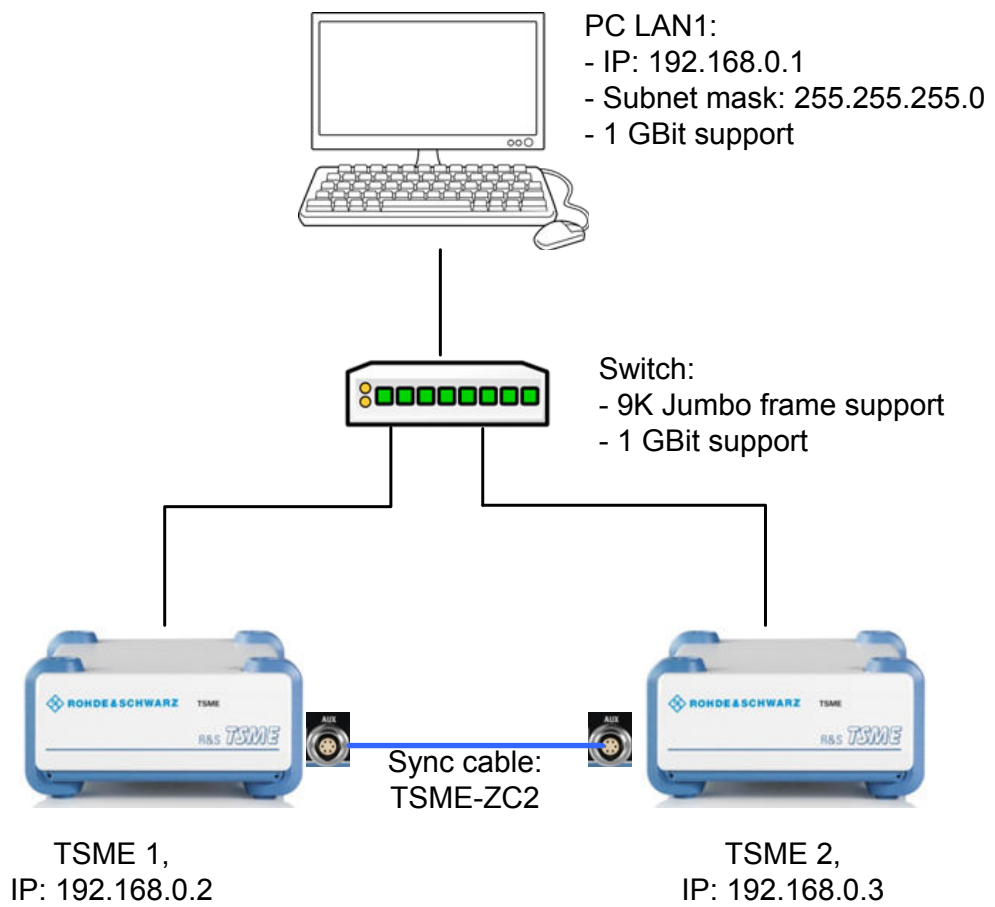

Figure 2-8: Configuration for parallel R&S TSME usage using a switch

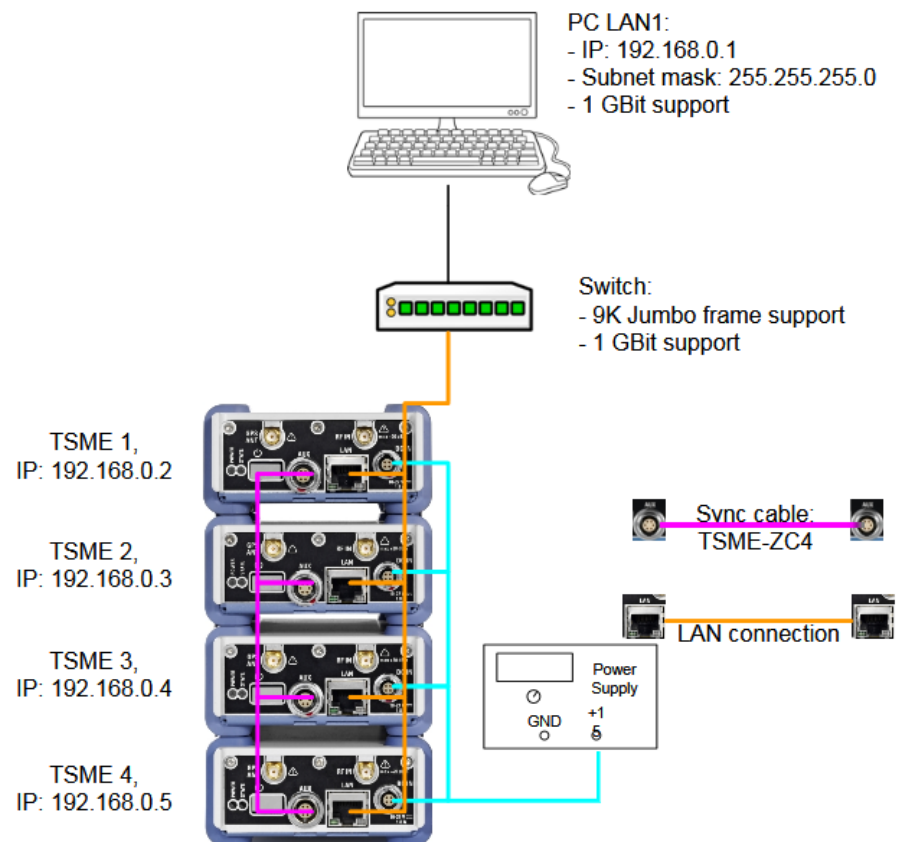

Figure 2-9: Configuration for LTE MIMO setup with four R&S TSMEs and a switch

To configure multiple R&S TSMEs connected to one host PC using a switch

1. Set up the LAN interface on the PC to use the following network settings, as described in [Chapter 2.2.2.1, "Configuring the LAN Interface on the Host PC"](#), on page 19:
 - **IP address:** 192.168.0.1
 - **Subnet mask:** 255.255.255.0
2. Change the IP addresses of the R&S TSMEs, as described in [Chapter 4.3, "Changing the IP Address for Multiple R&S TSME Configuration"](#), on page 45.
 - a) Start the R&S TSME Device Manager.
 - b) Connect the first R&S TSME to the PC.
 - c) Define the IP address: 192.168.0.2 (default).
 - d) Connect the second R&S TSME to the PC.
 - e) Define the IP address: 192.168.0.3.
 - f) Connect the third R&S TSME to the PC.
 - g) Define the IP address: 192.168.0.4.
 - h) Connect the fourth R&S TSME to the PC.
 - i) Define the IP address: 192.168.0.5.

- j) Close the R&S TSME Device Manager.
3. Check the IP connections in the R&S TSME Device Manager.
All connected and switched on R&S TSMEs should be displayed.
If not, see [Chapter 6, "Troubleshooting"](#), on page 59.

2.3 Switching the Instrument On and Off

To switch on the instrument

1. Use the supplied power cable to connect the power supply to the instrument.
2. Press the On/Off key on the rear panel of the R&S TSME.

After booting, the instrument switches to the idle mode and is ready to be accessed by an application.

For details on instrument modes see [Chapter 6.1, "Overview of Instrument Modes"](#), on page 59.

Switching off and standby mode

When you press the On/Off key on the rear panel of the R&S TSME to switch it off, the instrument changes to standby mode. In standby mode, the program execution on the instrument is stopped immediately, but the instrument is still under power connection.

NOTICE

Switching off during connection process

Do not switch off the instrument while a connection to the application software is being established, otherwise the application might not be able to close properly. As a result, the software could crash and must be shut down from the Windows Task Manager.

Removing the power supply

If you remove the power supply and reconnect it later, the behavior of the R&S TSME depends on the state of the instrument when the power was removed:

- **Standby mode:** the instrument returns to standby mode when power returns; must be switched on with the On/Off key
- **Any other operational mode:** the instrument automatically boots when power returns

2.4 Connecting the R&S TSME to a Software Application for the First Time

The following procedure describes the steps performed when you connect the R&S TSME to a software application (R&S ROMES, R&S NESTOR, or R&S ViCom) for the first time. Note that this process may take a few minutes initially.

1. Switch on the R&S TSME and the host PC.
2. Start the R&S ROMES / R&S NESTOR / R&S ViCom application on the host PC.
The application searches for R&S TSMEs connected to the host PC.
If the R&S TSME is detected by the software for the first time, the software downloads the calibration files from the R&S TSME to the host PC. This may take a few minutes.
3. If the firewall settings have not been defined to include the R&S TSME applications, a Windows Security Alert may appear. Change the firewall settings to permit access to the R&S TSME applications:

Connecting the R&S TSME to a Software Application for the First Time

- a) **Win 7:** In the Windows Control Panel, select "System and Security > Windows Firewall > Allow programs to communicate through Windows Firewall".
- Win10:** In the Windows Control Panel, select "System and Security > Windows Firewall > Allow apps to communicate through Windows Defender Firewall".

Allow programs to communicate through Windows Firewall

To add, change, or remove allowed programs and ports, click Change settings.

What are the risks of allowing a program to communicate?

Change settings

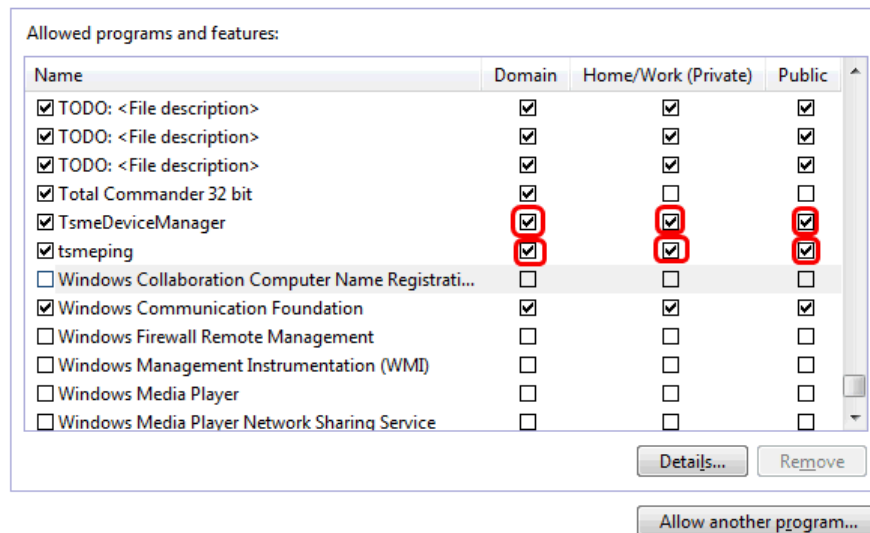

Figure 2-10: Firewall settings to permit application access (Win 7)

Allow apps to communicate through Windows Defender Firewall

To add, change, or remove allowed apps and ports, click Change settings.

What are the risks of allowing an app to communicate?

Change settings

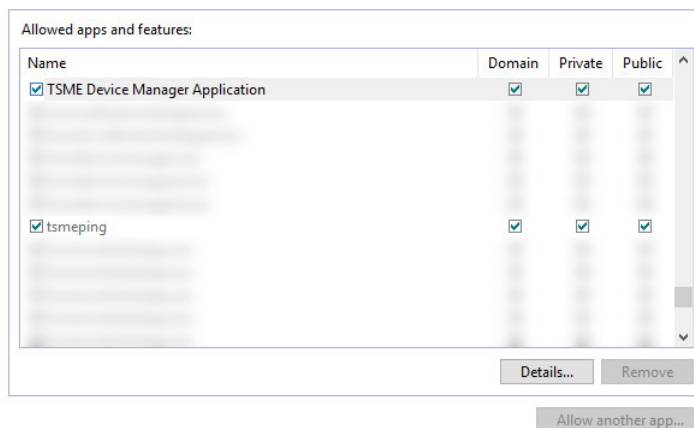
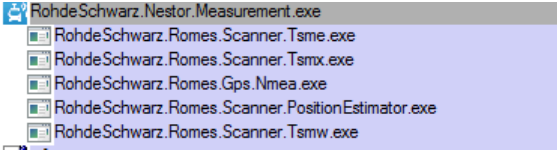

Figure 2-11: Firewall settings to permit application access (Win 10)

- b) Allow one or more specified application modules to communicate **on all three network types** (domain, private, public).

In particular, select:

- TSME Device Manager Application
- tsmeping

- c) Depending on which application is used, also select the following items:
- **R&S ROMES:**
 - ROMES.exe
 - Dll Loader for PHYLLIS Modules
(in the ROMES application folder)
 - **R&S NESTOR:**
 - RohdeSchwarz.Nestor.exe
 - 
 - **R&S ViCom:**
(User-specific) ViCom executable file
4. The application checks which firmware versions are installed on the R&S TSME and which version was used to boot the R&S TSME. Up to three firmware versions can be stored on the R&S TSME.
The following procedure depends on the detected version(s).
- If the firmware version required by the application was used for booting, the application establishes a connection to the R&S TSME directly.
 - If the firmware version required by the application is available on the R&S TSME, but was not used for booting, the application reboots the R&S TSME using the required firmware version. Then the application establishes a connection to the R&S TSME.
 - If the firmware version required by the application is not yet available on the R&S TSME, the application uploads the required firmware version to the R&S TSME (this may take about one minute). The application reboots the R&S TSME using the required firmware version, then establishes a connection to the R&S TSME.
 - If the firmware version required by the application is not yet available on the R&S TSME, and all three storage spaces for firmware are occupied by other versions, the application must do the following:
 - a) Clear all storage space for firmware versions on the R&S TSME (this may take about one minute).
 - b) Upload the required firmware version to the R&S TSME (this may take about one minute).
 - c) Reboot the R&S TSME using the required firmware version.
 - d) Establish a connection to the R&S TSME.

2.5 Checking the Instrument

The R&S TSME provides an application named R&S TSME Device Manager to check the state of the instrument. Operation and maintenance can also be performed using this tool. See [Chapter 4.1, "The R&S TSME Device Manager"](#), on page 42 for details.



The LEDs on the rear panel of the R&S TSME also indicate the state of the instrument, see [Table 3-1](#).

3 Front and Rear Panel Description

3.1 Front Panel

The front panel of the R&S TSME does not provide any connectors or control elements for operation.



Figure 3-1: Front panel view

3.2 Rear Panel

Figure [Figure 3-2](#) provides an overview of the control elements and the connectors on the rear panel of the instrument.

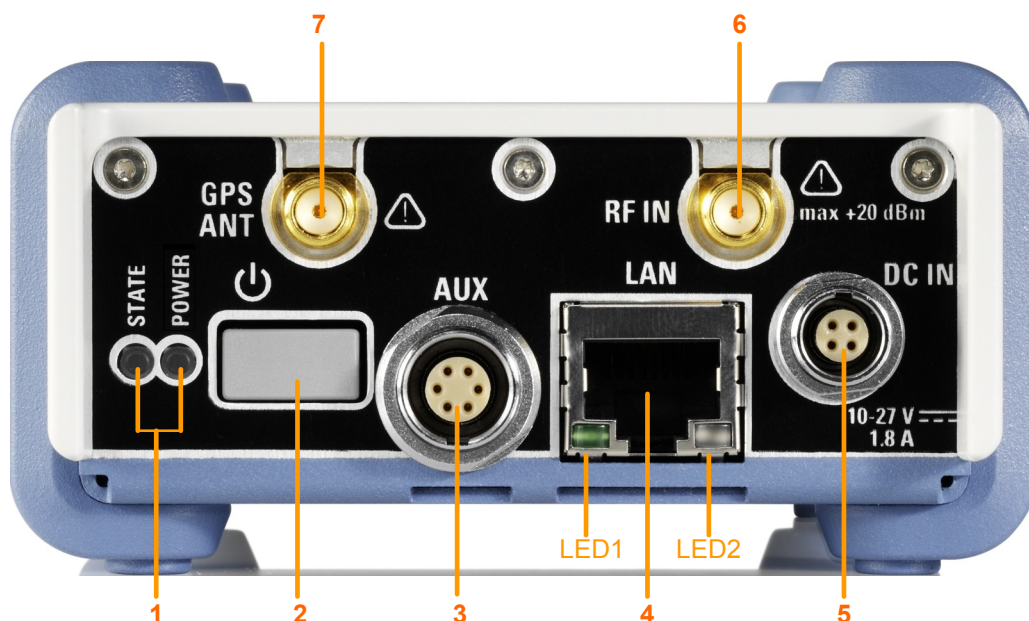

Figure 3-2: Rear panel view

- 1 = STATE / POWER LEDs
- 2 = On/Off key
- 3 = AUX connector
- 4 = LAN connector with LEDs
- 5 = DC IN connector
- 6 = RF IN connector
- 7 = GPS antenna connector

STATE / POWER LEDs

The [POWER] and [STATE] LEDs indicate the operating status of the R&S TSME.

Table 3-1: POWER and STATE LED states and their meaning

STATE LED	POWER LED	Meaning
off	off	no power supply connected at DC IN power supply off power supply < 10 V
off	yellow	standby
off	green, blinking (2 Hz)	FPGA configuration in progress
red (up to 5 seconds during startup)	green	FPGA configuration finished, preparing for start
off	green	R&S TSME ready, not connected
green	green	connected
green, blinking rapidly	green	measuring

STATE LED	POWER LED	Meaning
green, blinking 2 Hz	green, blinking 2 Hz	The instrument is being identified by the software (see "Identifying the currently selected device" on page 45).
red, blinking 2 Hz	green	temperature warning (controller board temperature = 65° C ... 70° C)
red (continuous)	green	temperature error (controller board temperature above 70° C)

On/Off Key

The On/Off key switches the instrument on and off if power is supplied via the DC IN connector. For details see [Chapter 2.3, "Switching the Instrument On and Off"](#), on page 33.

AUX Connector

The AUX connector can be used to connect additional devices, such as a signal generator that provides an external reference frequency for the R&S TSME, or a synchronization cable for multiple R&S TSMEs connected to one host PC.

LAN Connector

The LAN connector provides a high-speed Gigabit Ethernet interface with an RJ 45 connector using IPv4. It is required to connect the R&S TSME to a host PC.

For details see [Chapter 2.2.2, "Setting Up the LAN Connection to the Host PC"](#), on page 16.

The LEDs on the LAN connector indicate the status of the connection to the host PC. LED 1 is on the left side of the connector, LED 2 is on the right.

Table 3-2: LAN LED 1 states and their meaning

LED state	Description
off	No connection
green, blinking	Identifying connected device
green	Connection established

Table 3-3: LAN LED 2 states and their meaning

LED state	Description
off	No connection
green, blinking	Identifying connected device
green	Connection established; receiving good frame (valid data) or sending
yellow	Connection error; bad frame received (invalid data)

DC IN Connector

The DC IN connector is required for the DC power supply (10-27 V, max. 1.8 A).

For details see [Chapter 2.2.1, "Connecting the DC Power Supply"](#), on page 15.

RF IN 50 Ω Connector

The optional multi-band RF antenna (700 MHz to 2.6 GHz) or the device providing the RF signal is connected to the instrument's [RF Input] via a cable equipped with an appropriate connector (N female, 50 Ω input impedance, VSWR type 2.0).

NOTICE

Risk of instrument damage

Do not overload the maximum allowed input of 20dBm. Noncompliance will destroy the input mixer.



Depending on the intended use, the respective valid regulations regarding lightning protection of the antennas and regarding vehicle installation must be observed during installation.

GPS antenna connector

An SMA connector is provided for the supplied external active GPS antenna.

Antenna power: 3V, max. 25mA



Depending on the intended use, the respective valid regulations regarding lightning protection of the antennas and regarding vehicle installation must be observed during installation.

4 Basic R&S TSME Functions

Measurements are performed on the R&S TSME via the R&S ROMES, R&S NESTOR or R&S ViCom interface. Depending on the installed software options, the network is either scanned for individual standards, or globally over all frequency bands. Details on scanning networks are described in the R&S ROMES, R&S NESTOR and R&S ViCom manuals.

Basic device configuration tasks can be performed directly on the R&S TSME, via the host PC, using the R&S TSME Device Manager.

4.1 The R&S TSME Device Manager

The R&S TSME Device Manager is a configuration software tool for the R&S TSME. This utility is part of the R&S®TSME installation package. It can also be installed together with R&S ROMES, R&S NESTOR and R&S ViCom, and is available for download from the Rohde & Schwarz product website <https://www.rohde-schwarz.com/de/software/tsmx/>.

It provides the following tasks:

- Reading device information, such as:
 - Correction data status
 - Device temperatures
 - HW version
 - FPGA versions
 - Serial number
 - Warnings, errors or information concerning the device status
- Reading and setting the device's IP-address
- Reading and installing options
- For R&S TSMEs with limited band options:
 - Reading which bands are currently configured on the device
 - Changing the band configuration
- Updating basic FPGA and correction data



Administrator rights required

Note that the R&S TSME Device Manager requires administrator rights on the host PC in order to operate correctly.

To start the R&S TSME Device Manager

- ▶ To start the R&S TSME Device Manager, double-click the desktop icon or select the "R&S®TsmTools" program entry in the Windows "Start" menu.

If a connection to this application cannot be established correctly, check the firewall settings (see [Chapter 6.2, "Guide to Solving Instrument Connection Problems"](#), on page 61).

When you start the R&S TSME Device Manager, the following dialog box is displayed:

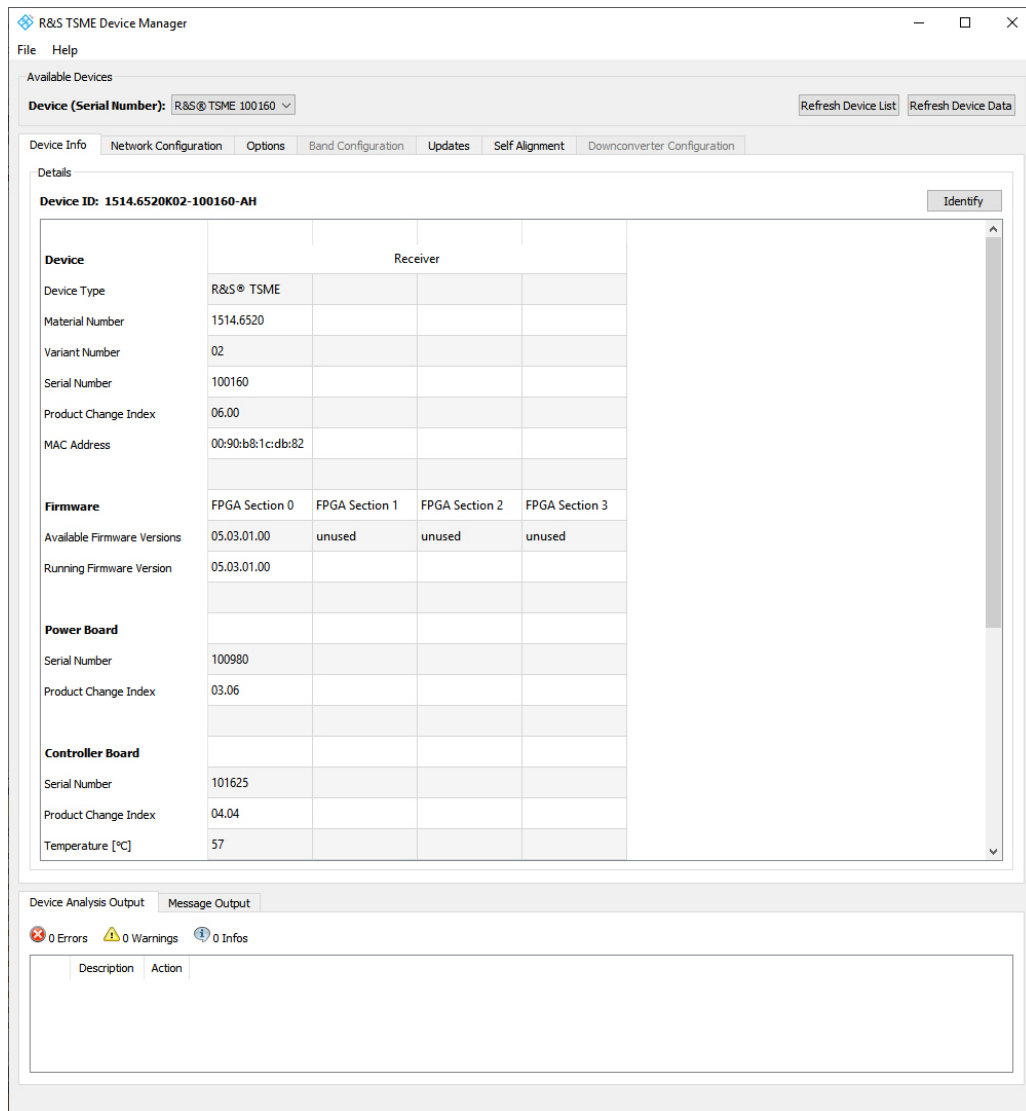

Figure 4-1: R&S TSME Device Manager

Selecting the device

The R&S TSME Device Manager can configure any connected R&S TSME that the software detects in the LAN. The individual devices are identified uniquely by their serial number. By selecting one of the "Available Devices" by its serial number in the R&S TSME Device Manager dialog box you determine which R&S TSME the current configuration applies to.

Updating the device selection list

If additional R&S TSMEs become available after the R&S TSME Device Manager has started, you must select the "Refresh Device List" button so the new devices are included in the "Available Devices" list.

Updating the displayed device data

If the current configuration or device information has changed and is not yet displayed correctly in the R&S TSME Device Manager, select the "Refresh Device Data" button to update the display.

4.2 Obtaining Device Information

The most important configuration settings for each available R&S TSME are displayed in the "Device Info" tab of the R&S TSME Device Manager (see [Figure 4-1](#)).

This includes the following information:

Table 4-1: R&S TSME device information

Label	Description
Device	
Device Type	Type of device (TSME family, TSMA family)
Material Number	Order number of the R&S TSME
Variant Number	Precise device type (variant)
Serial Number	Unique ID of the R&S TSME
Product Change Index	Version of the device
MAC Address	Network address of the R&S TSME
FPGA	
Available FPGA Bit File Versions	Previous firmware version backups stored on the device (see also " Automatic firmware updates " on page 54)
Current FPGA Bit File Version	Currently used firmware version
Power Board	
Serial Number	Unique ID of the power board
Product Change Index	Version of the power board
Controller Board	
Serial Number	Unique ID of the controller board
Product Change Index	Version of the controller board
Temperature	Current temperature of the hardware in [°]C
RF Board	
Serial Number	Unique ID of the RF board
Product Change Index	Version of the RF board

Label	Description
Temperature	Current temperature of the hardware in [°]C
Correction Data	
Version	Current version of the calibration data saved on the device
Type	<ul style="list-style-type: none"> • Factory The original factory calibration data are saved on the device. • Update An improved set of calibration data is available on saved on the device. (See "To perform an update" on page 50.)
Date	Timestamp of creating and saving the calibration data on the device
TCXO Date	Date of correction data for the internal reference

Device Analysis Output

Furthermore, any warnings, errors or information concerning the device status that may be available are displayed in the "Device Analysis Output" table. This table is available on all tabs, at the bottom of the R&S TSME Device Manager window.

Depending on their relevance, the messages are assigned to the following categories:

- **info**: information for the user, no action required
- **warning**: warning on behalf of the instrument - should be solved
- **error**: error on behalf of the instrument - must be solved before further operation



In case measurement problems occur with the R&S TSME, check the "Device Analysis Output" table for any errors that may have been detected. If available, a repair function is provided. See also [Chapter 6, "Troubleshooting"](#), on page 59.

Identifying the currently selected device

If several R&S TSMEs are connected to the host PC and are detected by the R&S TSME Device Manager, you may not be able to determine which of the (physical) devices is currently selected for configuration. When you select the "Identify" button, the STATE LED and the LAN LEDs on the rear panel of the device with the selected serial number start blinking rapidly for several seconds.

4.3 Changing the IP Address for Multiple R&S TSME Configuration

By default, each R&S TSME is delivered with the pre-configured IP address **192.168.0.2**. However, if multiple R&S TSMEs are connected to the same host PC, each device must have a unique IP address.

You can change the IP address for the connected R&S TSMEs directly via the R&S TSME Device Manager. If necessary, the LAN adapter settings on the host PC must also be adapted accordingly in order to reconnect with the R&S TSME (see also [Chapter 2.2.2, "Setting Up the LAN Connection to the Host PC"](#), on page 16). In partic-

ular, the host PC (LAN adapters) must use the subnet in which the IP addresses of the R&S TSMEs are located.

Define the IP address in the "Network Configuration" tab of the R&S TSME Device Manager. The currently active IP address for the selected R&S TSME is displayed for reference. It remains active until you select the "Accept Network Changes" button.

Auto IP Address

If "full auto-IP" operating mode is used, the "R&S TSME Device Manager" will show an extra field indicating the automatically generated IP address used for the connection to the host (see [Figure 4-2](#) with example IP address: 169.254.233.79).

In this case, the IP address stored in TSME (here 192.168.0.2) is still used as an identifier for the connection by the software applications, i.e. a kind of virtual IP address.

If partial auto-IP operating mode or static IP operating mode is used, the "R&S TSME Device Manager" will not show this extra field and the IP address stored in the R&S TSME is also the IP address used for the physical connection (in this example: 192.168.0.2).



The Auto IP functionality is only available with following versions of ROMES, ViCom and NESTOR software.

- R&S ROMES: Version 18.1 and later
- R&S ViCOM: Version 16.20 and later
- R&S NESTOR: Version 2.7.0 and later

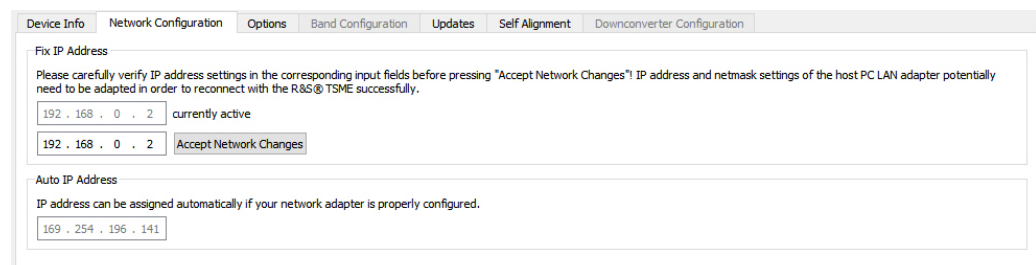

Figure 4-2: Tab "Network Configuration"

Applying changes to the LAN configuration

Changes to the IP Address configuration in the R&S TSME Device Manager are only applied when you select the "Accept Network Changes" button. The re-configured R&S TSME is then accessible only via the new IP address.

4.4 Installing and Managing Software License Keys

All new devices are preconfigured and specified technology and band options are already installed. Only if you obtain additional software options later you have to enable the options with the corresponding software license keys.

License keys are shipped as a printed "License Keys List". Advance deliveries may consist of a PDF file. Unregistered software licenses can be downloaded from the Rohde & Schwarz website (<https://extranet.rohde-schwarz.com/service>). For details see the "Installation Instructions for Options".

(Note: previously, license keys were shipped as xml files.)

Prerequisites to install software license keys

In order to install a software license key, the following conditions must apply:

- PC/notebook is connected via Gbit LAN adapter, with Jumbo Frames (9 kB) enabled
- The (registered) software license key must be available
- The R&S TSME is in idle mode, that is, it is switched on but no other software application is interacting with the R&S TSME (see [Chapter 6.1, "Overview of Instrument Modes"](#), on page 59).

Software license keys are installed using the R&S TSME Device Manager, in the "Options" tab.

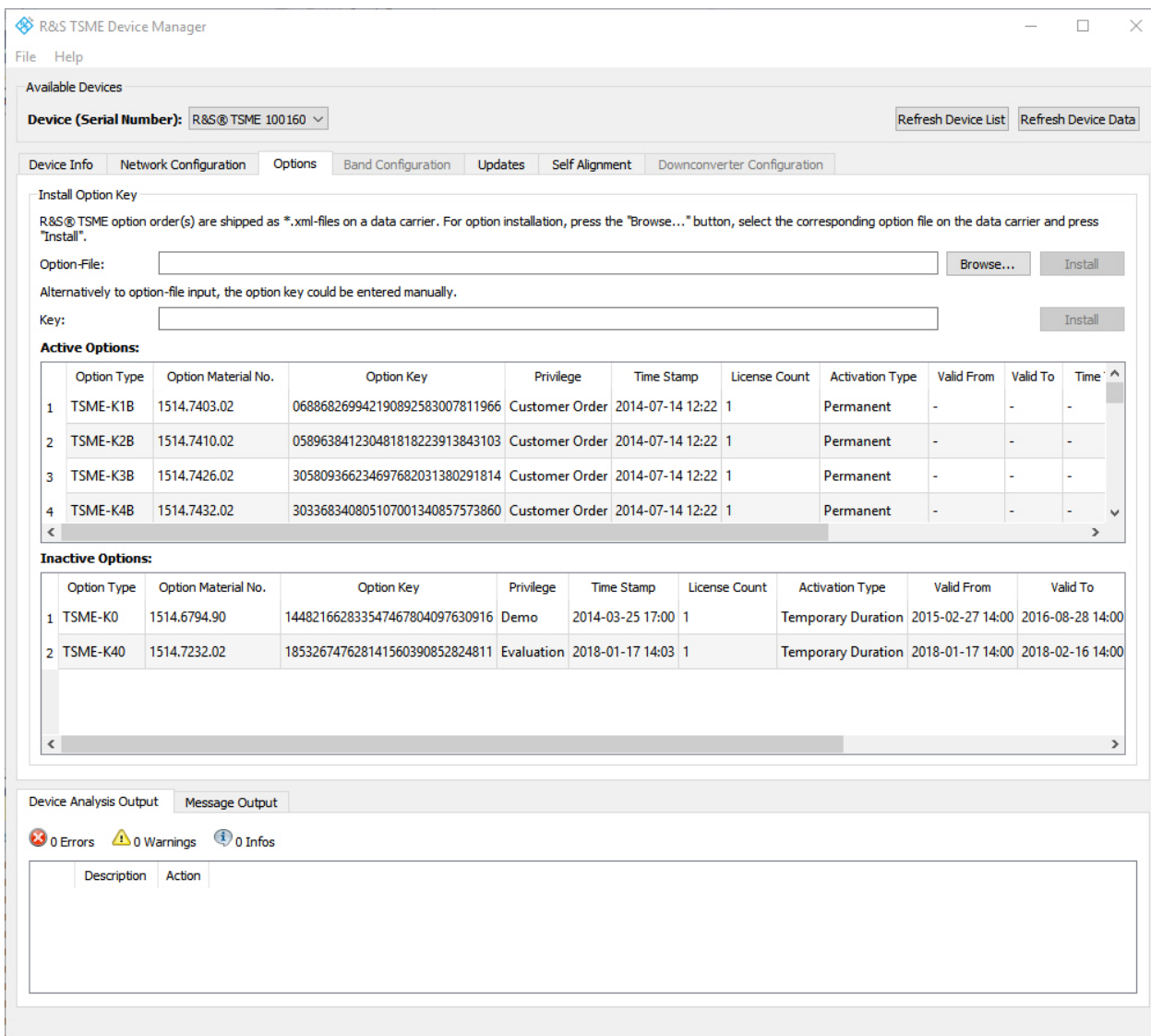

For each option, the following information is displayed:



Information for options that are no longer valid because their expiry date has passed are listed as "Inactive Options".

To replace temporary by permanent software license keys, contact your Rohde & Schwarz sales representative.

Table 4-2: Software license key information

Label	Description
Option Type	Band or technology option name
Option Material No.	Order number of the option
Option key	Software license key number
Privilege	Usage type (customer, services, demo)

Label	Description
Time Stamp	Time the software license key was installed
License Count	Number of times the (band upgrade) option is installed
Activation Type	Activation can be permanent or temporary
Valid From	Start of validity for temporary license
Valid To	End of validity for temporary license
Time to Expiration	Time left until license expires
Option Index	for internal use only
Format ID	for internal use only

Finding the software license key files

Previously, license keys were shipped as xml files. This function is only available for compatibility reasons.

If you do not know the precise path and file name of the required software license key, you can browse through the host PC's file system directly from the R&S TSME Device Manager, by selecting the "Browse" button in the "Options" tab.

Entering key codes

Enter the 30-digit key code from the "License Keys List" in the "Key" field.

Alternatively, if available, copy the key code from the supplied PDF license key file and paste it in the "Key" field.

To install the software license key on the currently selected R&S TSME, select the "Install" button (see ["Installing a software license key"](#) on page 49).

Installing a software license key

The software license key for which you have entered the key code in the R&S TSME Device Manager is installed on the currently selected R&S TSME when you select the "Install" button. It then appears in the "Active Options" list with its validity dates and other information (see [Table 4-2](#)).

4.5 Obtaining Firmware and Correction Data Updates

The R&S TSME Device Manager is always provided with the most recent basic FPGA (section 0). If a newer one becomes available due to security or functional issues, a message is indicated in the "Device Analysis Output" at the bottom of the R&S TSME Device Manager window. In this case, and only in this case, it is recommended that you install this update on your R&S TSME.

The correction data on your R&S TSME should always be kept up-to-date. Available updates are also indicated in the "Device Analysis Output" and it is recommended that you install them.

NOTICE**Risk of inoperability of device due to FPGA update**

Before performing an update, make sure you have a stable power supply and the LAN connection will not be interrupted. Both updates take a few minutes.

If the LAN connection is interrupted during an FPGA update, the device may become inoperable. Thus, only install such an update if it is explicitly recommended by a message in the "Device Analysis Output" of the R&S TSME Device Manager or by the Rohde & Schwarz support center.

You can update the basic FPGA or the correction data on your R&S TSME directly from the R&S TSME Device Manager, in the "Update" tab. The currently installed versions and the newest supported version (of the FPGA) or the minimum recommended version (of the correction data) are indicated.

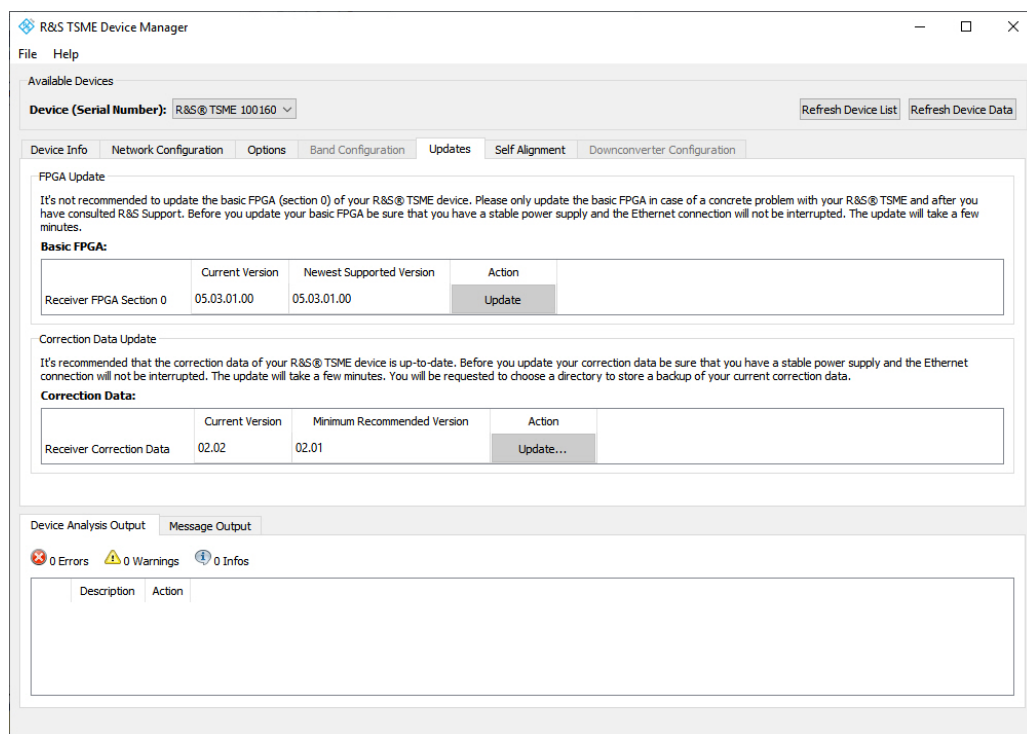
**To perform an update**

1. In the R&S TSME Device Manager, select the serial number of the R&S TSME to be updated.
2. In the "Update" tab, select the "Update" button for either the basic FPGA or the correction data.

When updating the correction data, you are asked to select a directory to store a backup of your current correction data.

4.6 Configuring Measurement Bands

Depending on which options are installed, various different bands and technologies can be scanned by the R&S TSME.



Before you can configure the measurement bands you must install all required software license keys, see [Chapter 4.4, "Installing and Managing Software License Keys"](#), on page 46.

The band configuration is stored on the R&S TSME and does not have to be performed every time you switch on the device.



When using a R&S TSME with a limited number of measurement bands (see [Chapter 1.3.2, "Band Options"](#), on page 9), you must consider the band configuration of the scanner when planning a measurement task. The scanner will only provide measurement results for those bands that are currently configured on the scanner.

Example:

A R&S TSME is configured with band option TSME-K2B (2 bands measured simultaneously). During the last measurement, the R&S TSME was used to perform measurements in 900 MHz and 1800 MHz bands. For the next measurement, the R&S TSME can still only be used in 900 MHz and 1800 MHz bands, unless you change the band configuration using the R&S TSME Device Manager.

The band configuration is defined in the "Band Configuration" tab of the R&S TSME Device Manager. Select the bands that are to be scanned by the R&S TSME in the "Band Table". Which bands are available is independent of the installed *technology* options; all installed technologies can be scanned in all configured bands at the same time. The *number* of bands available for selection depends on the installed band options (see [Chapter 1.3.2, "Band Options"](#), on page 9).

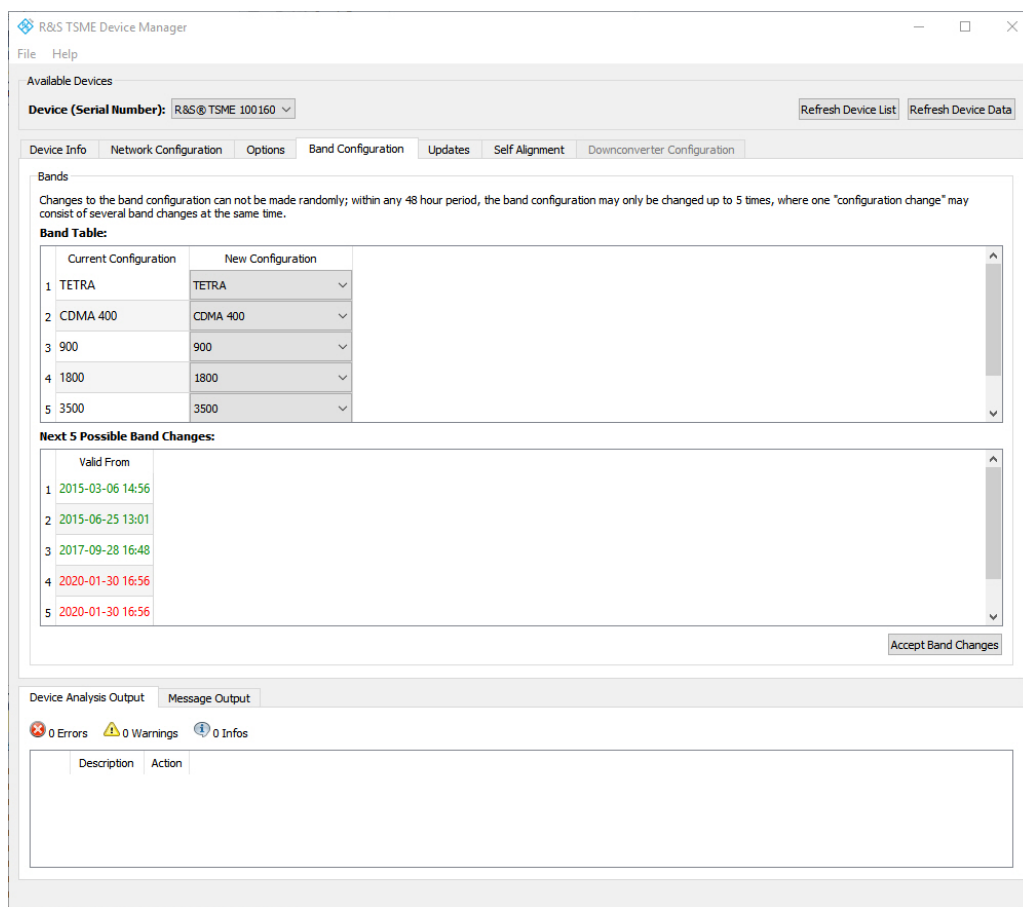

The current band configuration for the selected R&S TSME is displayed for reference. It remains active until you select the "Accept Band Changes" button.



Band configuration changes

Changes to the band configuration cannot be made randomly; within any 48-hour period, the band configuration may only be changed up to 5 times (where one "configuration change" may consist of several band changes at the same time, see ["Applying band configuration changes"](#) on page 52). A counter is decremented after each (applied) change. How many changes have already been performed and how many are still possible within the current time frame is displayed at the bottom of the "Band Configuration" tab of the R&S TSME Device Manager. Red dates indicate the changes recently made, while green dates indicate possible changes left.

Applying band configuration changes

Changes to the band configuration are only applied to the R&S TSME when you select the "Accept Band Changes" button in the "Band Configuration" tab of the R&S TSME Device Manager.

Only then the counter for possible band changes (within 48 hours) is decremented.

4.7 Aligning R&S TSME Manually

During self-alignment, the R&S TSME determines alignment values for the I/Q filter, ADC offset and the I/Q imbalance.

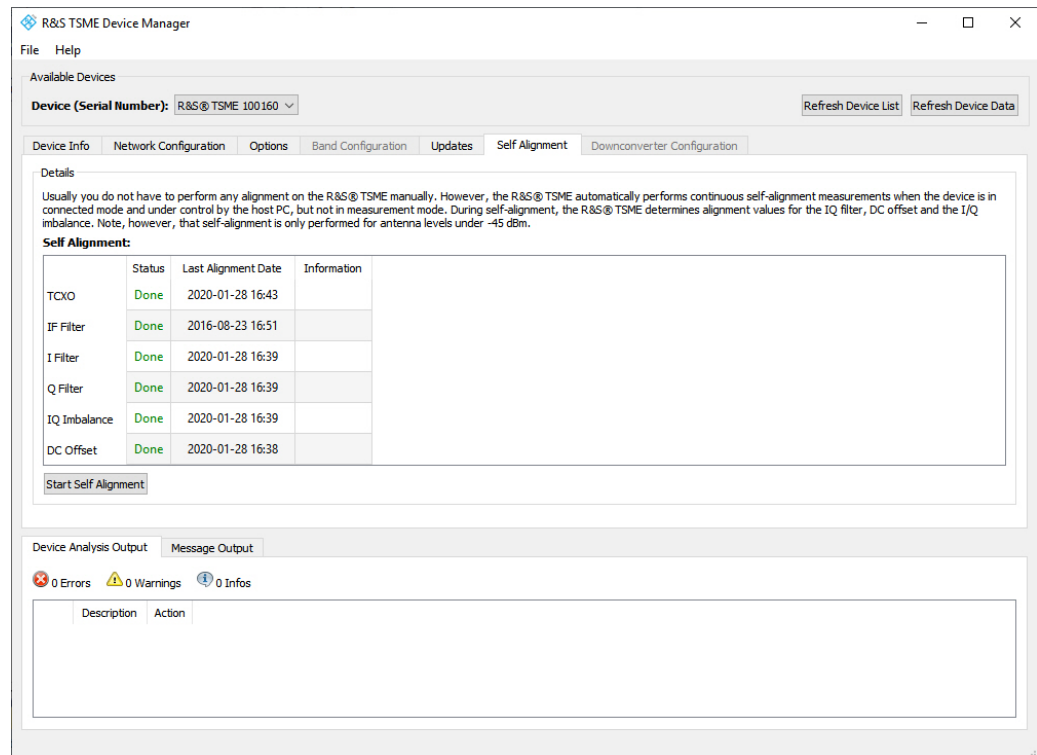

Figure 4-3: Tab "Self Alignment"

Start Self Alignment

To start the self-alignment manually, select the "Start Self Alignment" button in the Self Alignment tab of the "R&S TSME Device Manager".

4.8 Interacting with R&S ROMES, R&S NESTOR, and R&S ViCom

Measurements are performed on the R&S TSME via the R&S ROMES, R&S NESTOR, or R&S ViCom interface. Depending on the installed technology options, the network is either scanned for individual standards, or globally over all frequency bands.

An R&S TSME together with the R&S ROMES, R&S NESTOR, or R&S ViCom interface and the required technology options provides the following features:

- Parallel support of multiple wireless communications technologies
- Simultaneous measurements of GSM, WCDMA, CDMA2000®, 1xEVDO, WiMAX, TETRA and LTE technologies

- Calculation of base station locations from scanner measurements via R&S ROMES or R&S NESTOR software plus GPS position measurements plus high accuracy PPS
- Power scans over the entire frequency range from 350 MHz to 4400 MHz
- Simple scanner setup

The following sections briefly describe the basic requirements for interaction between the R&S TSME and the R&S ROMES, R&S NESTOR, or R&S ViCom interface. For details on using these interfaces see the R&S ROMES, R&S NESTOR, and R&S ViCom manuals.

4.8.1 Interacting with R&S ROMES

Prerequisites

In order to perform measurements with the R&S ROMES application, the following prerequisites apply:

- R&S ROMES Installation (refer to R&S ROMES manual)
- R&S ROMES option on dongle inserted (refer to R&S ROMES manual)
- Required technology options installed on the R&S TSME (see [Chapter 1.3.1, "Technology Options"](#), on page 8 and [Chapter 4.4, "Installing and Managing Software License Keys"](#), on page 46)
- Software options installed on the host PC (see information on the ROMES product page on the Rohde & Schwarz website: <https://www.rohde-schwarz.com/product/ROMES> > "Options")

After the R&S TSME has finished booting, start the R&S ROMES software application.



If a connection to this application cannot be established correctly, check the firewall settings (see [Chapter 6.2, "Guide to Solving Instrument Connection Problems"](#), on page 61)

Automatic firmware updates

Each time R&S ROMES is started, the software automatically compares the firmware version of the connected R&S TSME with the version currently available on the host PC. If a newer version is available, it is copied to and installed on the R&S TSME. Up to two previously installed firmware versions are stored as backups and maintained on the R&S TSME (see also [Table 4-1](#)). Thus, it is not necessary to perform firmware updates on the R&S TSME manually.

For details and information on how to configure R&S ROMES and carry out measurements with the R&S TSME, refer to the R&S ROMES manual.

4.8.2 Interacting with R&S NESTOR

Prerequisites

In order to perform measurements with the R&S NESTOR application, the following prerequisites apply:



For details on R&S NESTOR see the manual provided on the software DVD.

- R&S NESTOR installation on the host PC (refer to the R&S NESTOR manual)
- R&S NESTOR option on dongle inserted in host PC (refer to the R&S NESTOR manual)
- LAN connection between the R&S TSME and the host PC (note the special LAN adapter requirements specified in [Chapter 2.2.2, "Setting Up the LAN Connection to the Host PC"](#), on page 16)
- Required technology options installed on the R&S TSME (see [Chapter 1.3.1, "Technology Options"](#), on page 8 and [Chapter 4.4, "Installing and Managing Software License Keys"](#), on page 46)
- Software options installed on the host PC (see information on the NESTOR product page on the Rohde & Schwarz website: <https://www.rohde-schwarz.com/product/NESTOR> > "Options")
In particular, NESTOR SCN 1521.5031.xx (R&S Scanner Driver) is always required to operate the R&S TSME.

After the R&S TSME has finished booting, start the R&S NESTOR software application.



If a connection to this application cannot be established correctly, check the firewall settings (see [Chapter 6.2, "Guide to Solving Instrument Connection Problems"](#), on page 61)

Automatic firmware updates

Each time R&S NESTOR is started, the software automatically compares the firmware version of the connected R&S TSME with the version currently available on the host PC. If a newer version is available, it is copied to and installed on the R&S TSME. Up to two previously installed firmware versions are stored as backups and maintained on the R&S TSME (see also [Table 4-1](#)). Thus, it is not necessary to perform firmware updates on the R&S TSME manually.

For details and information on how to configure R&S NESTOR and carry out measurements with the R&S TSME, refer to the R&S NESTOR manual.

4.8.3 R&S ViCom Programming Interface



The R&S ViCom package is not part of the shipment.

R&S ViCom interface is a software package to develop software applications which integrate the R&S TSME as an OEM product into customer software.

The R&S ViCom package must be installed on the host PC. It includes documentation and sample applications.



Scanner Options

In order to interact with the R&S TSME via the R&S ViCom interface, the corresponding scanner options must be installed on the device. Open the R&S TSME Device Manager to see which scanner options are installed on the device (see [Chapter 4.4, "Installing and Managing Software License Keys"](#), on page 46).

For details and information on how to configure the R&S ViCom interface and carry out measurements with the R&S TSME, refer to the R&S ViCom manual.



If a connection to this application cannot be established correctly, check the firewall settings (see [Chapter 6.2, "Guide to Solving Instrument Connection Problems"](#), on page 61)

5 Maintenance

NOTICE

Instrument damage caused by cleaning agents

Cleaning agents contain substances such as solvents (thinners, acetone, etc.), acids, bases, or other substances. Solvents can damage the front panel labeling, plastic parts, or screens, for example.

Never use cleaning agents to clean the outside of the instrument. Use a soft, dry, lint-free dust cloth instead.

NOTICE

Risk of instrument damage during transportation and shipment

Insufficient protection against mechanical and electrostatic effects during transportation and shipment can damage the instrument.

- Always make sure that sufficient mechanical and electrostatic protection is provided.
- When shipping an instrument, the original packaging should be used. If this is not available, allow for sufficient padding to prevent the instrument from moving around inside the box. Pack the instrument in antistatic wrap to protect it from electrostatic charging.
- Secure the instrument to prevent any movement and other mechanical effects during transportation.

Firmware updates

You do not have to update the firmware on the R&S TSME manually. If necessary, firmware updates are downloaded from the host PC application (R&S ROMES, R&S NES-TOR, or R&S ViCom) automatically when the connection is established (see "[Automatic firmware updates](#)" on page 54).

Self-Alignment

Usually, you do not have to perform any alignment on the R&S TSME manually. However, the R&S TSME automatically performs continuous self-alignment measurements when the device is in connected mode and under control by the host PC, but not in measurement mode (for example it is loaded in ROMES, but no measurement is being performed, see also [Chapter 6.1, "Overview of Instrument Modes"](#), on page 59). During self-alignment, the R&S TSME determines alignment values for the I/Q filter, ADC offset and the I/Q imbalance. Note, however, that self-alignment is only performed for antenna levels under -45 dBm.

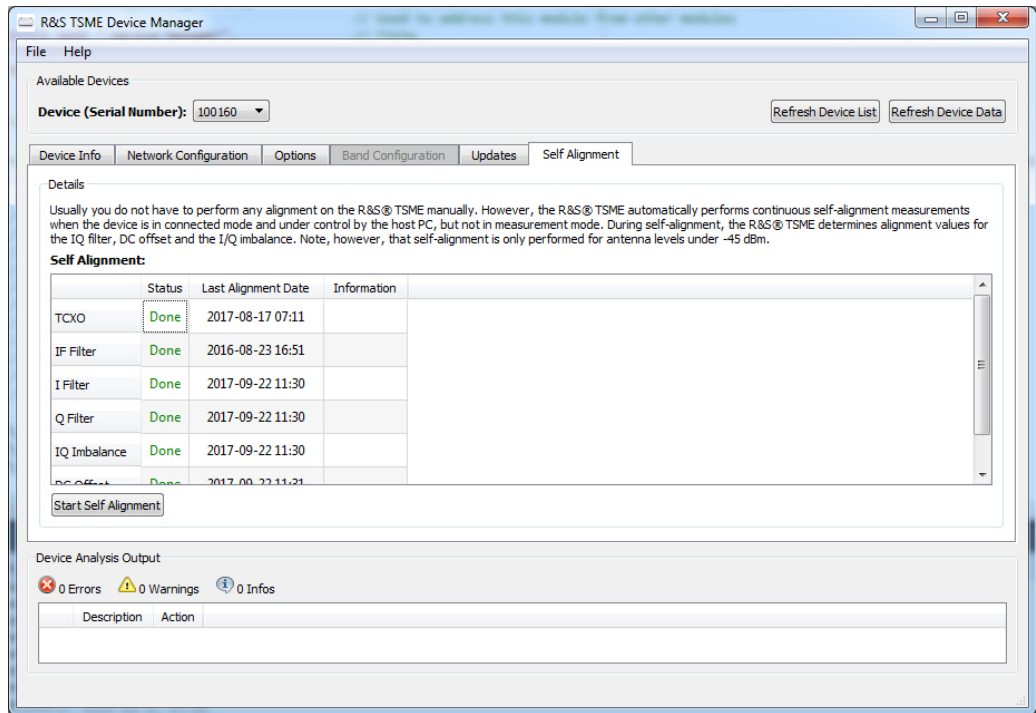

6 Troubleshooting

If errors occur during operation or connection of the R&S TSME, the following information may help you solve the issue.



Most errors that may occur during measurements with the R&S TSME are indicated in the host PC software (e.g. R&S ROMES, R&S NESTOR, or the R&S ViCom application) and must be solved within the software. This chapter refers only to errors that occur directly on the R&S TSME.

In case measurement problems occur with the R&S TSME, check the "Device Analysis Output" table in the R&S TSME Device Manager for any errors that may have been detected as a first measure (see [Chapter 4.1, "The R&S TSME Device Manager"](#), on page 42). If available, a repair function is provided.

6.1 Overview of Instrument Modes

Depending on the current operation and connection state of the R&S TSME, the instrument is considered to be in different modes. The possible modes and how to identify them are described here.



The meaning of the individual LED states is described in [Chapter 3.2, "Rear Panel"](#), on page 38.

Initial power on sequence

When the R&S TSME is supplied with power and switched on the first time after delivery, it automatically boots, performing the following steps before it is ready for operation:

1. FPGA configuration - indicated by a blinking green [POWER] LED.
2. FPGA configuration finished, preparing for start - indicated by a steady green [POWER] LED.
The red [STATE] LED lights up briefly (up to 5 seconds).
3. R&S TSME ready, not connected (Idle mode) - indicated by a green [POWER] LED; the [STATE] LED is off.

Idle mode

The state after booting has completed and before any connections have been established is referred to as *idle mode*.

This state is indicated by a green [POWER] LED; the [STATE] LED is off.

If you remove the power supply while the instrument is switched on and reconnect it later, the R&S TSME automatically boots again.

Connected mode

As soon as the host PC application (R&S ROMES or R&S NESTOR) or customer application based on the ViCom interface accesses the R&S TSME via the LAN interface, the R&S TSME switches to *connected mode*.

After establishing the connection to the R&S TSME, the first thing the host PC application does is to send the required application firmware to the R&S TSME. The R&S TSME is then ready for measurement commands sent from R&S ROMES, R&S NESTOR, or R&S ViCom.

The [STATE] LED is green.

Measuring mode

The instrument switches to *measuring mode* immediately after receiving any measuring command from the host PC software.

In measuring mode the [STATE] LED blinks green (rapidly).

Standby mode

When you press the "On/Off" key on the rear panel of the R&S TSME, the instrument switches to *standby mode*. Program execution on the instrument is stopped immediately, but the instrument is still under power connection. The [Power] LED is yellow, all other LEDs are off.

If you remove the power supply in standby mode and reconnect it later, the R&S TSME switches back to standby mode and does not automatically boot. You must press the "On/Off" key first to start booting.

Error mode

If an error occurs during operation and no measurements are possible, the R&S TSME falls into *error mode*.

The [STATE] LED turns red. If possible, warnings or errors are indicated in the "Device Analysis Output" table of the R&S TSME Device Manager (see [Chapter 4.2, "Obtaining Device Information"](#), on page 44).

The following diagram shows the order in which the R&S TSME goes through the various instrument modes.

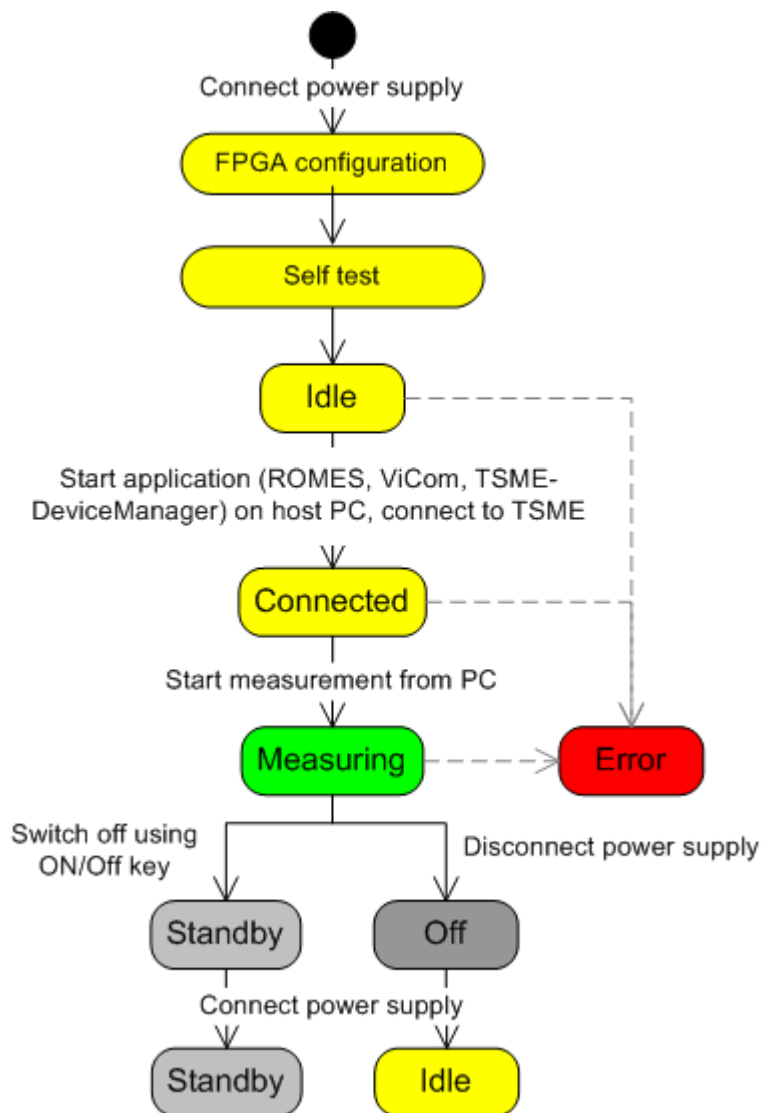
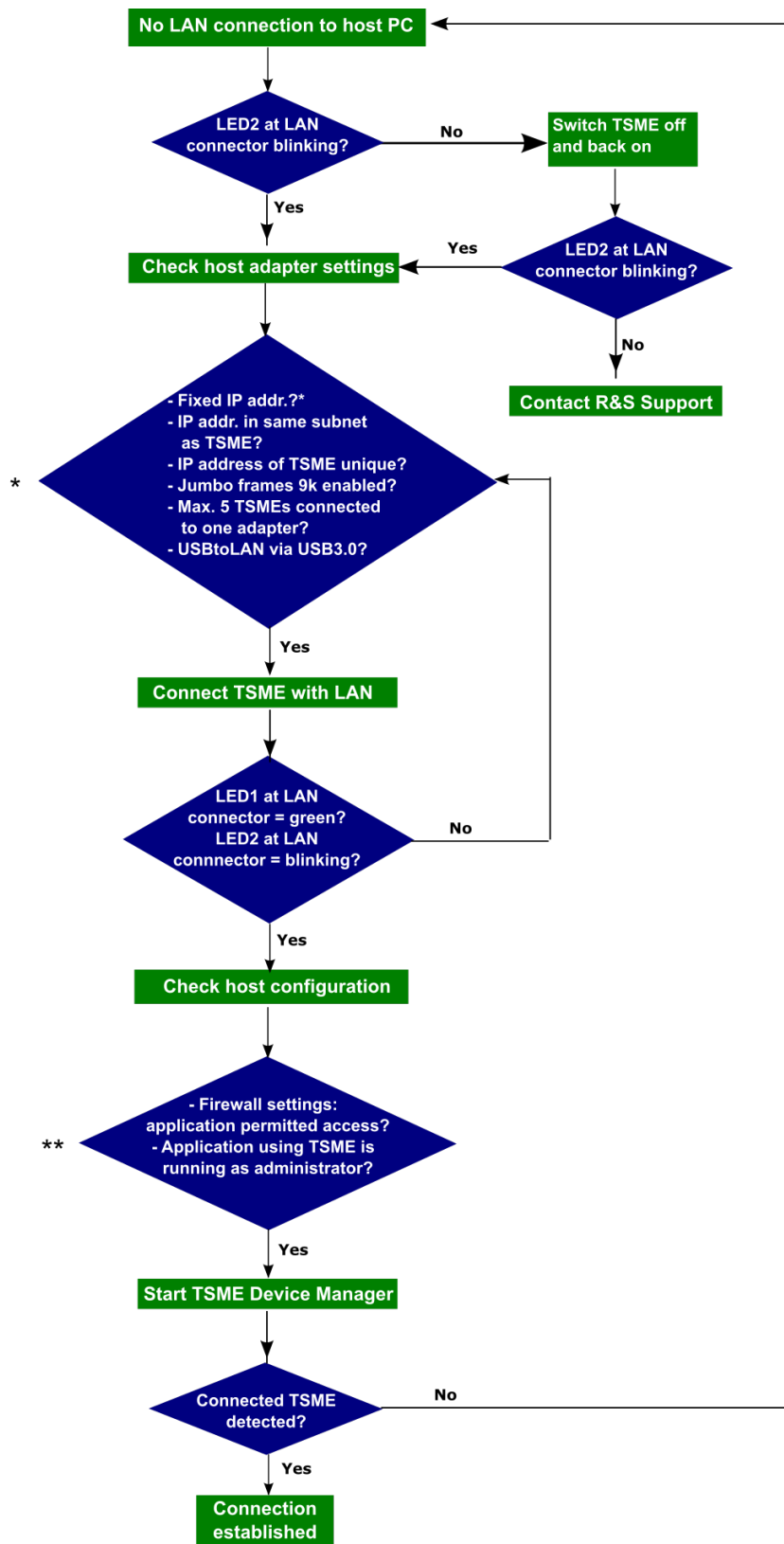

Figure 6-1: R&S TSME instrument modes

6.2 Guide to Solving Instrument Connection Problems

The following flow-diagram demonstrates how to check the LAN connection to the instrument when initial connection fails:



Scanner Link
OK

Figure 6-2: Troubleshooting: LAN Connection



Remarks to the troubleshooting flow-diagram

* For "full auto-IP" and "partial auto-IP" operating mode, following hints are valid:

- R&S TSME IP addresses are unique and physically in the network range (169.254.0.0 netmask 255.255.0.0).
- In "full auto-IP" operating mode, user has no control on IP addresses physically used.

** If the application using R&S TSME is not running as administrator, following problems may occur:

- The static ARP table conflicts with the dynamic configuration of R&S TSME. Clean up the ARP table or run the application as administrator to verify if the configuration is working.
- The host (respectively R&S TSME) is not be able to send and receive a multicast frame to IP address 239.192.1.5 port 16962.

The active firmware version must be 04.08.XX.00 or later (XX is the HW variant).

The following information may provide further solutions to frequent connection problems.

- Does the host provide a **Gbit LAN connector** and support **9k jumbo frames**? In some cases the Windows network adapter properties show that 9k are enabled, but in fact the adapter does not support the setting. You can **check this** using this command:

```
netsh interface ipv4 show interfaces
```

The "MTU" value in each line indicates the maximum transmission unit. Make sure the LAN adapter connected to the R&S TSME supports an MTU larger than 9000.

```
C:\Users\GASSLBAU>netsh interface ipv4 show interfaces
```

Idx	Met	MTU	State	Name
1	50	4294967295	connected	Loopback Pseudo-Interface 1
12	25	1500	disconnected	Wireless Network Connection
17	5	1500	disconnected	Wireless Network Connection 2
11	10	1500	connected	Local Area Connection
16	10	9000	disconnected	Local Area Connection 2

If the 9k jumbo frames cannot be enabled in the Windows dialog box, try the following command:

```
netsh interface ipv4 set subinterface [Idx] mtu=9000
store=persistent
```

where [Idx] is the network Id of the LAN adapter

For more information on the required settings see "[Important requirements for host PC](#)" on page 6.

- Are you using a USB2LAN adapter? Consider using an R&S TSPC-U2Ladapter, order no. 3593.8430.02.
- Does the **firewall** permit access to the R&S TSME applications? See [step 3](#) in [Chapter 2.4, "Connecting the R&S TSME to a Software Application for the First Time"](#), on page 34.
- Is the R&S TSME connected to the host PC properly?

Currently the R&S TSME does not answer to ICMP echo requests (PING). However, for ViCom users, a R&S TSME **Ping** tool is available after installation of R&S ViCom (C:\RuS\ViCom_15.0\tools\TSME\TsmPing.exe).

- Is the PC configured to use the subnet 192.168.0.0 with a different IP address to the R&S TSME (default: 192.168.0.2)? (See also [Chapter 2.2.2.1, "Configuring the LAN Interface on the Host PC"](#), on page 19.)
- Are **other applications** trying to access the R&S TSME at the same time (e.g. R&S ROMES, R&S NESTOR, R&S ViCom, R&S TSME Device Manager)? Check the Windows TaskManager and look for associated processes. If necessary, stop the processes.
- Is the host using **other network connections** at the same time, such as VPN? R&S TSME does not work when the PC is connected to VPN.
- Is the **connecting cable** between the host and the R&S TSME the one provided with the R&S TSME? Make sure you are using a quality CAT5e or better Gigabit Ethernet conform cable. RJ45 connectors must be shielded, not plastic.
- After switching the R&S TSME off and back on, is the **[power] LED** on the R&S TSME **blinking** while the **[state] LED** is **off**? This indicates that the TSME cannot boot. Contact Rohde & Schwarz Support Center.

6.3 Solving Other Miscellaneous Problems

In case measurement problems occur with the R&S TSME, check the "Device Analysis Output" table in the R&S TSME Device Manager for any errors that may have been detected as a first measure (see [Chapter 4.1, "The R&S TSME Device Manager"](#), on page 42).

Problem: R&S ROMES does not detect the R&S TSME	64
Problem: The R&S TSME Device Manager does not detect the R&S TSME	64
Problem: The options in the R&S TSME Device Manager are lost	65
Problem: MIMO operation on multiple R&S TSMEs fails	65
Problem: Error message: "No calibration data"	65
Problem: R&S TSME does not provide measurement data	65
Problem: The [STATE] LED is blinking red	65
Problem: Instrument shuts down at lower temperature than expected	65

Problem: R&S ROMES does not detect the R&S TSME

Possible solutions:

- Restart R&S ROMES, while the R&S TSME is connected and switched on.
- Restart the PC and then start R&S ROMES, while the R&S TSME is connected and switched on.

If you switch the instruments off and on again, be sure to switch on the R&S TSME before you start R&S ROMES!

Problem: The R&S TSME Device Manager does not detect the R&S TSME

Solution:

Be sure you have administrator rights on the host PC running the R&S TSME Device Manager.

Problem: The options in the R&S TSME Device Manager are lost

Solution:

Contact the Rohde & Schwarz Support Center.

Problem: MIMO operation on multiple R&S TSMEs fails

MIMO operation on multiple R&S TSMEs requires either a band option or the MIMO Extension option key R&S TSME-K300 on each of the R&S TSMEs (see [Chapter 2.2.5.2, "LTE MIMO Setups with Two R&S TSMEs"](#), on page 23). The K300 option is free of charge and is installed automatically at the factory. If for some reason this option is missing on your R&S TSME, contact the Rohde & Schwarz Support Center. You will receive the key free of charge.

Problem: Error message: "No calibration data"

Solution:

Delete the `TSME_ID_1514.6520K02-XXXXXX.cal` file in the application directory (e.g.

`C:\Program Files (x86)\Rohde-Schwarz\ROMES4.78` or `C:\RuS\ViCom_15.0\bin`) where `XXXXXX` is the serial number of the R&S TSME.

Problem: R&S TSME does not provide measurement data

Solution:

Delete the `TSME_ID_1514.6520K02-XXXXXX.cal` file in the application directory (e.g. `C:\Program Files (x86)\Rohde-Schwarz\ROMES4.78` or

`C:\RuS\ViCom_15.0\bin`) where `XXXXXX` is the serial number of the R&S TSME.

Problem: The [STATE] LED is blinking red

The instrument has become overheated. Check the airflow around the R&S TSME. If several instruments are stacked, set them side by side so each instrument can draw cool air from the bottom. If necessary, install an active cooling device. See the preconditions for setup described in ["Risk of instrument damage due to overheating"](#) on page 14.

Problem: Instrument shuts down at lower temperature than expected

By default, the instrument is set to shut down when it reaches a temperature of 75° C to prevent damage.

In rare occasions, it may shut down at a lower temperature. Check the "Device Analysis Output" in the R&S TSME Device Manager for a message and a repair function, if available.

Annex

A Available Cellular Bands

The following cellular bands are available for selection for R&S TSMEs with a limited band option (see [Chapter 1.3.2, "Band Options"](#), on page 9).

Table A-1: Available cellular bands for the R&S TSME

ID	TSME Band	Span	Start [MHz]	Stop [MHz]
1	"TETRA"	span 1	375	435
		span 2	445	475
		span 3	865	881
		span 4	910	926
2	"CDMA 400"	span 1	410	493
3	"480"	span 1	478	486
		span 2	488	496
4	"700"	span 1	698	862
5	"810"	span 1	806	821
		span 2	851	866
6	"850"	span 1	806	940
7	"900"	span 1	917	960
		span 2	872	915
8	"1400"	span 1	1427	1496
9	"PDC Japan"	span 1	1447	1463
		span 2	1495	1511
10	"1500/1600"	span 1	1626	1661
		span 2	1525	1559
11	"AWS"	span 1	1710	1780
		span 2	2110	2200
12	"1700"	span 1	1749	1785
		span 2	1840	1880
		span 3	1695	1710
		span 4	1995	2020
13	"1800"	span 1	1710	1785
		span 2	1805	1880
14	"1900"	span 1	1850	1915

ID	TSME Band	Span	Start [MHz]	Stop [MHz]
		span 2	1930	1995
15	"2100"	span 1	1920	2010
		span 2	2110	2200
16	"S-Band"	span 1	2000	2020
		span 2	2180	2200
17	"2600"	span 1	2496	2690
18	"3500"	span 1	3410	3490
		span 2	3510	3590
19	"WiMAX 7.x"	span 1	730	770
		span 2	890	903
		span 3	915	950
20	"WiMAX 8.A/TDD 1900/2000"	span 1	1785	1805
		span 2	1880	1930
		span 3	2010	2025
21	"TDD 1800"	span 1	1800	1830
22	"TDD 1930"	span 1	1930	1990
23	"TDD 2300"	span 1	2300	2400
24	"TDD 3300"	span 1	3300	3400
25	"TDD 3400"	span 1	3400	3600
26	"TDD 3600"	span 1	3600	3800
28	"ISM-Band"	span 1	433	435
		span 2	2400	2500
29	"600"	span 1	617	698

Table A-2: Additional information on cellular bands

ID	Band Name	Included standardized bands	UL low	UL high	DL low	DL high	Duplex
1	"TETRA"	T-GSM 380	380.2	389.8	390.2	399.8	FDD
		T-GSM 410	410.2	419.8	420.2	429.8	FDD
		GSM 450	450.4	457.6	460.4	467.6	FDD
		TETRA 380 to 400	380	390	390	400	FDD
		TETRA 410 to 430	410	420	420	430	FDD
		TETRA 450 to 470	450	460	460	470	FDD
		TETRA 900	870	876	915	921	FDD
		LTE Band 31	452.5	457.5	462.5	467.5	FDD

ID	Band Name	Included standardized bands	UL low	UL high	DL low	DL high	Duplex
2	"CDMA 400"	CDMA2000/EV-DO Band Class 11 (400 MHz European PAMR Band)	410	483	420	493	FDD
		CDMA2000/EV-DO Band Class 5 (450 MHz Band)	410	483	420	493	FDD
3	"480"	GSM 480	478.8	486	488.8	496	FDD
4	"700"	WiMAX 7.A	698	862	698	862	TDD
		CDMA2000/EV-DO Band Class 19 (Lower 700 MHz Band)	698	716	728	746	FDD
		LTE Band 12 (lower 700 A/B/C)	699	716	729	746	FDD
		3GPP WCDMA XII	699	716	729	746	FDD
		LTE Band 17 (lower 700 B)	704	716	734	746	FDD
		GSM 710	698	716	728	746	FDD
		LTE Band 44 TDD	703	803	703	803	TDD
		CDMA2000/EV-DO Band Class 7 (Upper 700 MHz Band)	776	788	746	758	FDD
		Band 13 (upper 700 C)	777	787	746	756	FDD
		WiMAX 7.B	776	787	746	757	FDD
		3GPP WCDMA XIII	777	787	746	756	FDD
		CDMA2000/EV-DO Band Class 18 (700 MHz Public Safety Band)	787	799	757	769	FDD
		LTE Band 14 (upper 700 D)	788	798	758	768	FDD
		3GPP WCDMA XIV	788	798	758	768	FDD
		WiMAX 7.C	788	798	758	768	FDD
		WiMAX 7.D	788	798	758	768	FDD
		GSM 750	777	793	747	763	FDD
		LTE Band 28 (700 APT)	703	748	758	803	FDD
		LTE Band 20	832	862	791	821	FDD
		3GPP WCDMA XX	832	862	791	821	FDD
LTE Band 29	N/A	N/A	717	728	FDD		
LTE Band 68	698	728	753	783	FDD		
LTE Band 67	N/A	N/A	738	758	FDD		
5	"810"	T-GSM 810	806	821	851	866	FDD
6	"850"	GSM 850	824	849	869	894	FDD
		3GPP WCDMA V	824	849	869	894	FDD
		LTE Band 5	824	849	869	894	FDD
		LTE Band 26	814	849	859	894	FDD

ID	Band Name	Included standardized bands	UL low	UL high	DL low	DL high	Duplex
		LTE Band 18	815	830	860	875	FDD
		CDMA2000/EV-DO Band Class 0 (800 MHz Band)	815	849	860	894	FDD
		CDMA2000/EV-DO Band Class 10 (Secondary 800 MHz Band)	806	901	851	940	FDD
		CDMA2000/EV-DO Band Class 12 (800 MHz PAMR Band)	870	876	915	921	FDD
		3GPP WCDMA VI	830	840	875	885	FDD
		3GPP WCDMA XIX	830	845	875	890	FDD
		3GPP WCDMA XXVI	814	849	859	894	FDD
		LTE Band 27	807	824	852	869	FDD
		LTE Band 6	830	840	875	885	FDD
		LTE Band 19	830	845	875	890	FDD
		TETRA 900	870	876	915	921	FDD
		CDMA2000/EV-DO Band Class 3 (JTACS Band)	887	925	832	870	FDD
7	"900"	P-GSM 900	890	915	935	960	FDD
		E-GSM 900 (includes P-GSM 900)	880	915	925	960	FDD
		R-GSM 900 (includes E-GSM 900)	876	915	921	960	FDD
		3GPP WCDMA VIII	880	915	925	960	FDD
		LTE Band 8	880	915	925	960	FDD
		WiMAX 7.G	880	915	925	960	FDD
		CDMA2000/EV-DO Band Class 9 (900 MHz Band)	880	915	925	960	FDD
		CDMA2000/EV-DO Band Class 2 (TACS Band)	872	915	917	960	FDD
8	"1400"	3GPP WCDMA XI	1427.9	1447.9	1475.9	1495.9	FDD
		LTE Band 11	1427.9	1447.9	1475.9	1495.9	FDD
		LTE Band 32	N/A	N/A	1452	1496	FDD
		LTE Band 45	1447	1467	1447	1467	TDD
		3GPP WCDMA Band XXXII	N/A	N/A	1452	1496	FDD
9	"PDC Japan"	3GPP WCDMA XXI	1447.9	1462.9	1495.9	1510.9	FDD
		LTE Band 21	1447.9	1462.9	1495.9	1510.9	FDD
10	"1500/1600"	CDMA2000/EV-DO Band Class 20 (L-Band)	1626	1660	1525	1559	FDD
		LTE Band 24	1626.5	1660.5	1525	1559	FDD

ID	Band Name	Included standardized bands	UL low	UL high	DL low	DL high	Duplex
11	"AWS"	3GPP WCDMA IV	1710	1755	2110	2155	FDD
		3GPP WCDMA X	1710	1770	2110	2170	FDD
		LTE Band 4	1710	1755	2110	2155	FDD
		LTE Band 10	1710	1770	2110	2170	FDD
		CDMA2000/EV-DO Band Class 15 (AWS Band)	1710	1755	2110	2155	FDD
		WiMAX 6.A	1710	1770	2110	2170	FDD
		LTE Band 66	1710	1780	2110	2200	FDD
12	"1700"	3GPP WCDMA IX	1749.9	1784.9	1844.9	1879.9	FDD
		LTE Band 9 (UMTS1700)	1749.9	1784.9	1844.9	1879.9	FDD
		CDMA2000/EV-DO Band Class 4 (Korean PCS Band)	1750	1780	1840	1870	FDD
		LTE Band 70	1695	1710	1995	2020	FDD
13	"1800"	DCS 1800	1710	1785	1805	1880	FDD
		3GPP WCDMA III	1710	1785	1805	1880	FDD
		LTE Band 3	1710	1785	1805	1880	FDD
		CDMA2000/EV-DO Band Class 8 (1800 MHz Band)	1710	1785	1805	1880	FDD
		WiMAX 6.C	1710	1785	1805	1880	FDD
14	"1900"	PCS 1900	1850	1910	1930	1990	FDD
		3GPP WCDMA II	1850	1910	1930	1990	FDD
		3GPP WCDMA XXV	1850	1915	1930	1995	FDD
		3GPP TDD incl. TD-SCDMA b	1850	1910	1930	1990	TDD
		LTE Band 2	1850	1910	1930	1990	FDD
		LTE Band 35 TDD	1850	1910	1850	1910	TDD
		CDMA2000/EV-DO Band Class 1 (1900 MHz Band)	1850	1910	1930	1990	FDD
		CDMA2000/EV-DO Band Class 14 (US PCS 1.9GHz Band)	1850	1915	1930	1995	FDD
		LTE Band 25 (PCS A-G superset of band 2)	1850	1915	1930	1995	FDD
		3GPP WCDMA I	1920	1980	2110	2170	FDD
15	"2100"	LTE Band 1	1920	1980	2110	2170	FDD
		CDMA2000/EV-DO Band Class 6 (2 GHz IMT2000 Band)	1920	1980	2110	2170	FDD
		WiMAX 6.B	1920	1980	2110	2170	FDD

ID	Band Name	Included standardized bands	UL low	UL high	DL low	DL high	Duplex
		LTE Band 65	1920	2010	2110	2200	FDD
16	"S-Band"	LTE Band 23	2000	2020	2180	2200	FDD
		CDMA2000/EV-DO Band Class 21 (S-Band)	2000	2020	2180	2200	FDD
17	"2600"	LTE Band 7	2500	2570	2620	2690	FDD
		CDMA2000/EV-DO Band Class 13 (25 GHz IMT-2000 Extension Band)	2500	2570	2620	2690	FDD
		3GPP WCDMA VII	2500	2570	2620	2690	FDD
		CDMA2000/EV-DO Band Class 16 (US 2.5 GHz Band)	2502	2568	2624	2690	FDD
		CDMA2000/EV-DO Band Class 17 (US 2.5 GHz Forward Link Only Band)			2624	2690	FDD (DL only)
		LTE Band 41 TDD	2496	2690	2496	2690	TDD
		WiMAX 3.A	2496	2690	2496	2690	TDD
		WiMAX 3.B	2496	2572	2614	2690	FDD
		LTE Band 38 TDD	2570	2620	2570	2620	TDD
		3GPP TDD incl. TD-SCDMA d	2570	2620	2570	2620	TDD
		LTE Band 69	N/A	N/A	2570	2620	FDD
18	"3500"	3GPP WCDMA XXII	3410	3490	3510	3590	FDD
		LTE Band 22	3410	3490	3510	3590	FDD
19	"WiMAX 7.x"	7.x* lower	730	770	730	770	TDD
		7.x* mid	890	903	890	903	TDD
		7.x* higher	915	950	915	950	TDD
20	"WiMAX 8.A/TDD 1900/2000"	WiMAX 8.A lower	1785	1805	1785	1805	TDD
		WiMAX 8.A mid	1880	1930	1880	1930	TDD
		WiMAX 8.A upper	2010	2025	2010	2025	TDD
		3GPP TDD incl. TD-SCDMA a (lower)	1900	1920	1900	1920	TDD
		LTE Band 33 TDD	1900	1920	1900	1920	TDD
		3GPP TDD incl. TD-SCDMA c	1910	1930	1910	1930	TDD
		LTE Band 37 TDD	1910	1930	1910	1930	TDD
		3GPP TDD incl. TD-SCDMA f	1880	1920	1880	1920	TDD
		LTE Band 39 TDD	1880	1920	1880	1920	TDD
		3GPP TDD incl. TD-SCDMA a (upper)	2010	2025	2010	2025	TDD
		LTE Band 34 TDD	2010	2025	2010	2025	TDD

ID	Band Name	Included standardized bands	UL low	UL high	DL low	DL high	Duplex
21	"TDD 1800"	WiMAX 8.G	1800	1830	1800	1830	TDD
22	"TDD 1930"	LTE Band 36 TDD	1930	1990	1930	1990	TDD
23	"TDD 2300"	LTE Band 40 TDD	2300	2400	2300	2400	TDD
		3GPP TDD incl. TD-SCDMA e	2300	2400	2300	2400	TDD
		WiMAX 1.A	2300	2400	2300	2400	TDD
		WiMAX 1.B	2300	2400	2300	2400	TDD
		WiMAX 2.D (lower)	2305	2320	2305	2320	TDD
		WiMAX 2.D (upper)	2345	2360	2345	2360	TDD
		WiMAX 2.E	2345	2360	2305	2320	FDD
		WiMAX 2.F	2345	2360	2305	2320	FDD
		LTE Band 30	2305	2315	2350	2360	FDD
24	"TDD 3300"	WiMAX 4.A	3300	3400	3300	3400	TDD
		WiMAX 4.B	3300	3400	3300	3400	TDD
		WiMAX 4.C	3300	3400	3300	3400	TDD
25	"TDD 3400"	LTE Band 42 TDD	3400	3600	3400	3600	TDD
		WiMAX 5L.A	3400	3600	3400	3600	TDD
		WiMAX 5L.B	3400	3600	3400	3600	TDD
		WiMAX 5L.C	3400	3600	3400	3600	TDD
		WiMAX 5L.D	3400	3500	3500	3600	FDD
26	"TDD 3600"	LTE Band 43 TDD	3600	3800	3600	3800	TDD
		WiMAX 5H.A	3600	3800	3600	3800	TDD
		WiMAX 5H.B	3600	3800	3600	3800	TDD
		WiMAX 5H.C	3600	3800	3600	3800	TDD
28	"ISM-Band"	ISM 433	433	435	433	435	TDD
		ISM 2400	2400	2500	2400	2500	TDD
29	"600"	LTE Band 71 - US Digital Dividend	663	698	617	652	TDD

Index

A		Idle mode	59
AUX		Instrument modes	59
Connector	40		
B		K	
Backpack system	13	Kensington Lock	
Band options	9	Connecting	22
Available	9	L	
C		LAN	
Connected mode	60	Configuration	16
Connectors		Connector	40
AUX	40	LAN connection	
DC IN	40	Troubleshooting	61
GPS antenna	41	LEDs	
LAN	40	Power	39
Overview	38	State	39
Rear panel	38	Locks	
RF IN	41	Connecting	22
D		M	
DC IN		Measuring mode	60
Connector	40	O	
Device data		On/Off key	40
Updating	44, 46, 52, 53	Options	
Device list		Band	9
Selecting devices	43	P	
Updating	44	Power	
Device Manager		LED	39
Finding software license keys	49	Power supply	
Installing software license keys	49	Removing	33
Selecting devices	43	R	
Software license keys	49	Rackmounting	13
Updating device data	44, 46, 52, 53	RF IN	
Updating device list	44	Connector	41
E		S	
Electrostatic discharge	11	Self-alignment	57
Equipment		Software license keys	49
Required	7	Finding	49
Error mode	60	Information	48
ESD	11	Installing	46
F		Managing	46
Firmware updates	57	Prerequisites	47
G		Updating	49
GPS		Standby mode	33, 60
Antenna connector	41	State	
H		LED	39
Host PC	6	Switching on/off	33
I		T	
Identifying		Technology options	8
Configuration	45	Available	8

Troubleshooting
 LAN connection 61

U

Updates
 Firmware 57