

R&S® UPP

Audio Analyzer

Quick Start Guide



1411106162

This operating manual describes the Audio Analyzers

- R&S®UPP200
- R&S®UPP400
- R&S®UPP800

and their options.

The software contained in this product uses several valuable open source software packages. For information, see the "Open Source Acknowledgment" document, which is available for download from the R&S UPP product page at www.rohde-schwarz.com/de/firmware/upp/.

Rohde & Schwarz would like to thank the open source community for their valuable contribution to embedded computing.

© 2018 Rohde & Schwarz GmbH & Co. KG

Mühlhofstr. 15, 81671 München, Germany

Phone: +49 89 41 29 - 0

Fax: +49 89 41 29 12 164

Email: info@rohde-schwarz.com

Internet: www.rohde-schwarz.com

Subject to change – Data without tolerance limits is not binding.

R&S® is a registered trademark of Rohde & Schwarz GmbH & Co. KG.

Trade names are trademarks of the owners.

1411.1061.62 | Version 09 | R&S®UPP

The following abbreviations are used throughout this manual: R&S®UPP is abbreviated as R&S UPP.

Basic Safety Instructions

Always read through and comply with the following safety instructions!

All plants and locations of the Rohde & Schwarz group of companies make every effort to keep the safety standards of our products up to date and to offer our customers the highest possible degree of safety. Our products and the auxiliary equipment they require are designed, built and tested in accordance with the safety standards that apply in each case. Compliance with these standards is continuously monitored by our quality assurance system. The product described here has been designed, built and tested in accordance with the EC Certificate of Conformity and has left the manufacturer's plant in a condition fully complying with safety standards. To maintain this condition and to ensure safe operation, you must observe all instructions and warnings provided in this manual. If you have any questions regarding these safety instructions, the Rohde & Schwarz group of companies will be happy to answer them.



Furthermore, it is your responsibility to use the product in an appropriate manner. This product is designed for use solely in industrial and laboratory environments or, if expressly permitted, also in the field and must not be used in any way that may cause personal injury or property damage. You are responsible if the product is used for any purpose other than its designated purpose or in disregard of the manufacturer's instructions. The manufacturer shall assume no responsibility for such use of the product.

The product is used for its designated purpose if it is used in accordance with its product documentation and within its performance limits (see data sheet, documentation, the following safety instructions). Using the product requires technical skills and, in some cases, a basic knowledge of English. It is therefore essential that only skilled and specialized staff or thoroughly trained personnel with the required skills be allowed to use the product. If personal safety gear is required for using Rohde & Schwarz products, this will be indicated at the appropriate place in the product documentation. Keep the basic safety instructions and the product documentation in a safe place and pass them on to the subsequent users.











Observing the safety instructions will help prevent personal injury or damage of any kind caused by dangerous situations. Therefore, carefully read through and adhere to the following safety instructions before and when using the product. It is also absolutely essential to observe the additional safety instructions on personal safety, for example, that appear in relevant parts of the product documentation. In these safety instructions, the word "product" refers to all merchandise sold and distributed by the Rohde & Schwarz group of companies, including instruments, systems and all accessories. For product-specific information, see the data sheet and the product documentation.

Safety labels on products

The following safety labels are used on products to warn against risks and dangers.

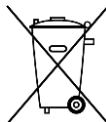
Symbol	Meaning	Symbol	Meaning
	Notice, general danger location Observe product documentation	○	ON/OFF Power
	Caution when handling heavy equipment	⏻	Standby indication
	Danger of electric shock	≡	Direct current (DC)

Basic Safety Instructions

Symbol	Meaning	Symbol	Meaning
	Caution ! Hot surface		Alternating current (AC)
	Protective conductor terminal To identify any terminal which is intended for connection to an external conductor for protection against electric shock in case of a fault, or the terminal of a protective earth		Direct/alternating current (DC/AC)
	Earth (Ground)		Class II Equipment to identify equipment meeting the safety requirements specified for Class II equipment (device protected by double or reinforced insulation)
	Frame or chassis Ground terminal		EU labeling for batteries and accumulators For additional information, see section "Waste disposal/Environmental protection", item 1.
	Be careful when handling electrostatic sensitive devices		EU labeling for separate collection of electrical and electronic devices For additional information, see section "Waste disposal/Environmental protection", item 2.
	Warning! Laser radiation For additional information, see section "Operation", item 7.		

Signal words and their meaning

The following signal words are used in the product documentation in order to warn the reader about risks and dangers.



Indicates a hazardous situation which, if not avoided, will result in death or serious injury.



Indicates a hazardous situation which, if not avoided, could result in death or serious injury.



Indicates a hazardous situation which, if not avoided, could result in minor or moderate injury.



Indicates information considered important, but not hazard-related, e.g. messages relating to property damage.

In the product documentation, the word ATTENTION is used synonymously.

These signal words are in accordance with the standard definition for civil applications in the European Economic Area. Definitions that deviate from the standard definition may also exist in other economic areas or military applications. It is therefore essential to make sure that the signal words described here are always used only in connection with the related product documentation and the related product. The use of signal words in connection with unrelated products or documentation can result in misinterpretation and in personal injury or material damage.

Basic Safety Instructions

Operating states and operating positions

The product may be operated only under the operating conditions and in the positions specified by the manufacturer, without the product's ventilation being obstructed. If the manufacturer's specifications are not observed, this can result in electric shock, fire and/or serious personal injury or death. Applicable local or national safety regulations and rules for the prevention of accidents must be observed in all work performed.

1. Unless otherwise specified, the following requirements apply to Rohde & Schwarz products: predefined operating position is always with the housing floor facing down, IP protection 2X, use only indoors, max. operating altitude 2000 m above sea level, max. transport altitude 4500 m above sea level. A tolerance of $\pm 10\%$ shall apply to the nominal voltage and $\pm 5\%$ to the nominal frequency, overvoltage category 2, pollution degree 2.
2. Do not place the product on surfaces, vehicles, cabinets or tables that for reasons of weight or stability are unsuitable for this purpose. Always follow the manufacturer's installation instructions when installing the product and fastening it to objects or structures (e.g. walls and shelves). An installation that is not carried out as described in the product documentation could result in personal injury or even death.
3. Do not place the product on heat-generating devices such as radiators or fan heaters. The ambient temperature must not exceed the maximum temperature specified in the product documentation or in the data sheet. Product overheating can cause electric shock, fire and/or serious personal injury or even death.

Electrical safety

If the information on electrical safety is not observed either at all or to the extent necessary, electric shock, fire and/or serious personal injury or death may occur.

1. Prior to switching on the product, always ensure that the nominal voltage setting on the product matches the nominal voltage of the mains-supply network. If a different voltage is to be set, the power fuse of the product may have to be changed accordingly.
2. In the case of products of safety class I with movable power cord and connector, operation is permitted only on sockets with a protective conductor contact and protective conductor.
3. Intentionally breaking the protective conductor either in the feed line or in the product itself is not permitted. Doing so can result in the danger of an electric shock from the product. If extension cords or connector strips are implemented, they must be checked on a regular basis to ensure that they are safe to use.
4. If there is no power switch for disconnecting the product from the mains, or if the power switch is not suitable for this purpose, use the plug of the connecting cable to disconnect the product from the mains. In such cases, always ensure that the power plug is easily reachable and accessible at all times. For example, if the power plug is the disconnecting device, the length of the connecting cable must not exceed 3 m. Functional or electronic switches are not suitable for providing disconnection from the AC supply network. If products without power switches are integrated into racks or systems, the disconnecting device must be provided at the system level.
5. Never use the product if the power cable is damaged. Check the power cables on a regular basis to ensure that they are in proper operating condition. By taking appropriate safety measures and carefully laying the power cable, ensure that the cable cannot be damaged and that no one can be hurt by, for example, tripping over the cable or suffering an electric shock.

Basic Safety Instructions

6. The product may be operated only from TN/TT supply networks fuse-protected with max. 16 A (higher fuse only after consulting with the Rohde & Schwarz group of companies).
7. Do not insert the plug into sockets that are dusty or dirty. Insert the plug firmly and all the way into the socket provided for this purpose. Otherwise, sparks that result in fire and/or injuries may occur.
8. Do not overload any sockets, extension cords or connector strips; doing so can cause fire or electric shocks.
9. For measurements in circuits with voltages $V_{rms} > 30$ V, suitable measures (e.g. appropriate measuring equipment, fuse protection, current limiting, electrical separation, insulation) should be taken to avoid any hazards.
10. Ensure that the connections with information technology equipment, e.g. PCs or other industrial computers, comply with the IEC 60950-1 / EN 60950-1 or IEC 61010-1 / EN 61010-1 standards that apply in each case.
11. Unless expressly permitted, never remove the cover or any part of the housing while the product is in operation. Doing so will expose circuits and components and can lead to injuries, fire or damage to the product.
12. If a product is to be permanently installed, the connection between the protective conductor terminal on site and the product's protective conductor must be made first before any other connection is made. The product may be installed and connected only by a licensed electrician.
13. For permanently installed equipment without built-in fuses, circuit breakers or similar protective devices, the supply circuit must be fuse-protected in such a way that anyone who has access to the product, as well as the product itself, is adequately protected from injury or damage.
14. Use suitable overvoltage protection to ensure that no overvoltage (such as that caused by a bolt of lightning) can reach the product. Otherwise, the person operating the product will be exposed to the danger of an electric shock.
15. Any object that is not designed to be placed in the openings of the housing must not be used for this purpose. Doing so can cause short circuits inside the product and/or electric shocks, fire or injuries.
16. Unless specified otherwise, products are not liquid-proof (see also section "Operating states and operating positions", item 1). Therefore, the equipment must be protected against penetration by liquids. If the necessary precautions are not taken, the user may suffer electric shock or the product itself may be damaged, which can also lead to personal injury.
17. Never use the product under conditions in which condensation has formed or can form in or on the product, e.g. if the product has been moved from a cold to a warm environment. Penetration by water increases the risk of electric shock.
18. Prior to cleaning the product, disconnect it completely from the power supply (e.g. AC supply network or battery). Use a soft, non-linting cloth to clean the product. Never use chemical cleaning agents such as alcohol, acetone or diluents for cellulose lacquers.

Operation

1. Operating the products requires special training and intense concentration. Make sure that persons who use the products are physically, mentally and emotionally fit enough to do so; otherwise, injuries or material damage may occur. It is the responsibility of the employer/operator to select suitable personnel for operating the products.

Basic Safety Instructions

2. Before you move or transport the product, read and observe the section titled "Transport".
3. As with all industrially manufactured goods, the use of substances that induce an allergic reaction (allergens) such as nickel cannot be generally excluded. If you develop an allergic reaction (such as a skin rash, frequent sneezing, red eyes or respiratory difficulties) when using a Rohde & Schwarz product, consult a physician immediately to determine the cause and to prevent health problems or stress.
4. Before you start processing the product mechanically and/or thermally, or before you take it apart, be sure to read and pay special attention to the section titled "Waste disposal/Environmental protection", item 1.
5. Depending on the function, certain products such as RF radio equipment can produce an elevated level of electromagnetic radiation. Considering that unborn babies require increased protection, pregnant women must be protected by appropriate measures. Persons with pacemakers may also be exposed to risks from electromagnetic radiation. The employer/operator must evaluate workplaces where there is a special risk of exposure to radiation and, if necessary, take measures to avert the potential danger.
6. Should a fire occur, the product may release hazardous substances (gases, fluids, etc.) that can cause health problems. Therefore, suitable measures must be taken, e.g. protective masks and protective clothing must be worn.
7. Laser products are given warning labels that are standardized according to their laser class. Lasers can cause biological harm due to the properties of their radiation and due to their extremely concentrated electromagnetic power. If a laser product (e.g. a CD/DVD drive) is integrated into a Rohde & Schwarz product, absolutely no other settings or functions may be used as described in the product documentation. The objective is to prevent personal injury (e.g. due to laser beams).
8. EMC classes (in line with EN 55011/CISPR 11, and analogously with EN 55022/CISPR 22, EN 55032/CISPR 32)
 - Class A equipment:
Equipment suitable for use in all environments except residential environments and environments that are directly connected to a low-voltage supply network that supplies residential buildings
Note: Class A equipment is intended for use in an industrial environment. This equipment may cause radio disturbances in residential environments, due to possible conducted as well as radiated disturbances. In this case, the operator may be required to take appropriate measures to eliminate these disturbances.
 - Class B equipment:
Equipment suitable for use in residential environments and environments that are directly connected to a low-voltage supply network that supplies residential buildings

Repair and service

1. The product may be opened only by authorized, specially trained personnel. Before any work is performed on the product or before the product is opened, it must be disconnected from the AC supply network. Otherwise, personnel will be exposed to the risk of an electric shock.

Basic Safety Instructions

- Adjustments, replacement of parts, maintenance and repair may be performed only by electrical experts authorized by Rohde & Schwarz. Only original parts may be used for replacing parts relevant to safety (e.g. power switches, power transformers, fuses). A safety test must always be performed after parts relevant to safety have been replaced (visual inspection, protective conductor test, insulation resistance measurement, leakage current measurement, functional test). This helps ensure the continued safety of the product.

Batteries and rechargeable batteries/cells

If the information regarding batteries and rechargeable batteries/cells is not observed either at all or to the extent necessary, product users may be exposed to the risk of explosions, fire and/or serious personal injury, and, in some cases, death. Batteries and rechargeable batteries with alkaline electrolytes (e.g. lithium cells) must be handled in accordance with the EN 62133 standard.

- Cells must not be taken apart or crushed.
- Cells or batteries must not be exposed to heat or fire. Storage in direct sunlight must be avoided. Keep cells and batteries clean and dry. Clean soiled connectors using a dry, clean cloth.
- Cells or batteries must not be short-circuited. Cells or batteries must not be stored in a box or in a drawer where they can short-circuit each other, or where they can be short-circuited by other conductive materials. Cells and batteries must not be removed from their original packaging until they are ready to be used.
- Cells and batteries must not be exposed to any mechanical shocks that are stronger than permitted.
- If a cell develops a leak, the fluid must not be allowed to come into contact with the skin or eyes. If contact occurs, wash the affected area with plenty of water and seek medical aid.
- Improperly replacing or charging cells or batteries that contain alkaline electrolytes (e.g. lithium cells) can cause explosions. Replace cells or batteries only with the matching Rohde & Schwarz type (see parts list) in order to ensure the safety of the product.
- Cells and batteries must be recycled and kept separate from residual waste. Rechargeable batteries and normal batteries that contain lead, mercury or cadmium are hazardous waste. Observe the national regulations regarding waste disposal and recycling.
- Follow the transport stipulations of the carrier (IATA-DGR, IMDG-Code, ADR, RID) when returning lithium batteries to Rohde & Schwarz subsidiaries.

Transport

- The product may be very heavy. Therefore, the product must be handled with care. In some cases, the user may require a suitable means of lifting or moving the product (e.g. with a lift-truck) to avoid back or other physical injuries.
- Handles on the products are designed exclusively to enable personnel to transport the product. It is therefore not permissible to use handles to fasten the product to or on transport equipment such as cranes, fork lifts, wagons, etc. The user is responsible for securely fastening the products to or on the means of transport or lifting. Observe the safety regulations of the manufacturer of the means of transport or lifting. Noncompliance can result in personal injury or material damage.

Basic Safety Instructions

3. If you use the product in a vehicle, it is the sole responsibility of the driver to drive the vehicle safely and properly. The manufacturer assumes no responsibility for accidents or collisions. Never use the product in a moving vehicle if doing so could distract the driver of the vehicle. Adequately secure the product in the vehicle to prevent injuries or other damage in the event of an accident.

Waste disposal/Environmental protection

1. Specially marked equipment has a battery or accumulator that must not be disposed of with unsorted municipal waste, but must be collected separately. It may only be disposed of at a suitable collection point or via a Rohde & Schwarz customer service center.
2. Waste electrical and electronic equipment must not be disposed of with unsorted municipal waste, but must be collected separately.
Rohde & Schwarz GmbH & Co. KG has developed a disposal concept and takes full responsibility for take-back obligations and disposal obligations for manufacturers within the EU. Contact your Rohde & Schwarz customer service center for environmentally responsible disposal of the product.
3. If products or their components are mechanically and/or thermally processed in a manner that goes beyond their intended use, hazardous substances (heavy-metal dust such as lead, beryllium, nickel) may be released. For this reason, the product may only be disassembled by specially trained personnel. Improper disassembly may be hazardous to your health. National waste disposal regulations must be observed.
4. If handling the product releases hazardous substances or fuels that must be disposed of in a special way, e.g. coolants or engine oils that must be replenished regularly, the safety instructions of the manufacturer of the hazardous substances or fuels and the applicable regional waste disposal regulations must be observed. Also observe the relevant safety instructions in the product documentation. The improper disposal of hazardous substances or fuels can cause health problems and lead to environmental damage.

For additional information about environmental protection, visit the Rohde & Schwarz website.

Instrucciones de seguridad elementales

¡Es imprescindible leer y cumplir las siguientes instrucciones e informaciones de seguridad!

El principio del grupo de empresas Rohde & Schwarz consiste en tener nuestros productos siempre al día con los estándares de seguridad y de ofrecer a nuestros clientes el máximo grado de seguridad. Nuestros productos y todos los equipos adicionales son siempre fabricados y examinados según las normas de seguridad vigentes. Nuestro sistema de garantía de calidad controla constantemente que sean cumplidas estas normas. El presente producto ha sido fabricado y examinado según el certificado de conformidad de la UE y ha salido de nuestra planta en estado impecable según los estándares técnicos de seguridad. Para poder preservar este estado y garantizar un funcionamiento libre de peligros, el usuario deberá atenerse a todas las indicaciones, informaciones de seguridad y notas de alerta. El grupo de empresas Rohde & Schwarz está siempre a su disposición en caso de que tengan preguntas referentes a estas informaciones de seguridad.

Además queda en la responsabilidad del usuario utilizar el producto en la forma debida. Este producto está destinado exclusivamente al uso en la industria y el laboratorio o, si ha sido expresamente autorizado, para aplicaciones de campo y de ninguna manera deberá ser utilizado de modo que alguna persona/cosa pueda sufrir daño. El uso del producto fuera de sus fines definidos o sin tener en cuenta las instrucciones del fabricante queda en la responsabilidad del usuario. El fabricante no se hace en ninguna forma responsable de consecuencias a causa del mal uso del producto.

















Se parte del uso correcto del producto para los fines definidos si el producto es utilizado conforme a las indicaciones de la correspondiente documentación del producto y dentro del margen de rendimiento definido (ver hoja de datos, documentación, informaciones de seguridad que siguen). El uso del producto hace necesarios conocimientos técnicos y ciertos conocimientos del idioma inglés. Por eso se debe tener en cuenta que el producto solo pueda ser operado por personal especializado o personas instruidas en profundidad con las capacidades correspondientes. Si fuera necesaria indumentaria de seguridad para el uso de productos de Rohde & Schwarz, encontraría la información debida en la documentación del producto en el capítulo correspondiente. Guarde bien las informaciones de seguridad elementales, así como la documentación del producto, y entréguelas a usuarios posteriores.

Tener en cuenta las informaciones de seguridad sirve para evitar en lo posible lesiones o daños por peligros de toda clase. Por eso es imprescindible leer detalladamente y comprender por completo las siguientes informaciones de seguridad antes de usar el producto, y respetarlas durante el uso del producto. Deberán tenerse en cuenta todas las demás informaciones de seguridad, como p. ej. las referentes a la protección de personas, que encontrarán en el capítulo correspondiente de la documentación del producto y que también son de obligado cumplimiento. En las presentes informaciones de seguridad se recogen todos los objetos que distribuye el grupo de empresas Rohde & Schwarz bajo la denominación de "producto", entre ellos también aparatos, instalaciones así como toda clase de accesorios. Los datos específicos del producto figuran en la hoja de datos y en la documentación del producto.

Instrucciones de seguridad elementales

Señalización de seguridad de los productos

Las siguientes señales de seguridad se utilizan en los productos para advertir sobre riesgos y peligros.

Símbolo	Significado	Símbolo	Significado
	Aviso: punto de peligro general Observar la documentación del producto		Tensión de alimentación de PUESTA EN MARCHA / PARADA
	Atención en el manejo de dispositivos de peso elevado		Indicación de estado de espera (standby)
	Peligro de choque eléctrico		Corriente continua (DC)
	Advertencia: superficie caliente		Corriente alterna (AC)
	Conexión a conductor de protección		Corriente continua / Corriente alterna (DC/AC)
	Conexión a tierra		El aparato está protegido en su totalidad por un aislamiento doble (reforzado)
	Conexión a masa		Distintivo de la UE para baterías y acumuladores Más información en la sección "Eliminación/protección del medio ambiente", punto 1.
	Aviso: Cuidado en el manejo de dispositivos sensibles a la electrostática (ESD)		Distintivo de la UE para la eliminación por separado de dispositivos eléctricos y electrónicos Más información en la sección "Eliminación/protección del medio ambiente", punto 2.
	Advertencia: rayo láser Más información en la sección "Funcionamiento", punto 7.		

Instrucciones de seguridad elementales

Palabras de señal y su significado

En la documentación del producto se utilizan las siguientes palabras de señal con el fin de advertir contra riesgos y peligros.



Indica una situación de peligro que, si no se evita, causa lesiones graves o incluso la muerte.



Indica una situación de peligro que, si no se evita, puede causar lesiones graves o incluso la muerte.



Indica una situación de peligro que, si no se evita, puede causar lesiones leves o moderadas.



Indica información que se considera importante, pero no en relación con situaciones de peligro; p. ej., avisos sobre posibles daños materiales.

En la documentación del producto se emplea de forma sinónima el término CUIDADO.

Las palabras de señal corresponden a la definición habitual para aplicaciones civiles en el área económica europea. Pueden existir definiciones diferentes a esta definición en otras áreas económicas o en aplicaciones militares. Por eso se deberá tener en cuenta que las palabras de señal aquí descritas sean utilizadas siempre solamente en combinación con la correspondiente documentación del producto y solamente en combinación con el producto correspondiente. La utilización de las palabras de señal en combinación con productos o documentaciones que no les correspondan puede llevar a interpretaciones equivocadas y tener por consecuencia daños en personas u objetos.

Estados operativos y posiciones de funcionamiento

El producto solamente debe ser utilizado según lo indicado por el fabricante respecto a los estados operativos y posiciones de funcionamiento sin que se obstruya la ventilación. Si no se siguen las indicaciones del fabricante, pueden producirse choques eléctricos, incendios y/o lesiones graves con posible consecuencia de muerte. En todos los trabajos deberán ser tenidas en cuenta las normas nacionales y locales de seguridad del trabajo y de prevención de accidentes.

1. Si no se convino de otra manera, es para los productos Rohde & Schwarz válido lo que sigue: como posición de funcionamiento se define por principio la posición con el suelo de la caja para abajo, modo de protección IP 2X, uso solamente en estancias interiores, utilización hasta 2000 m sobre el nivel del mar, transporte hasta 4500 m sobre el nivel del mar. Se aplicará una tolerancia de $\pm 10\%$ sobre el voltaje nominal y de $\pm 5\%$ sobre la frecuencia nominal. Categoría de sobrecarga eléctrica 2, índice de suciedad 2.
2. No sitúe el producto encima de superficies, vehículos, estantes o mesas, que por sus características de peso o de estabilidad no sean aptos para él. Siga siempre las instrucciones de instalación del fabricante cuando instale y asegure el producto en objetos o estructuras (p. ej. paredes y estantes). Si se realiza la instalación de modo distinto al indicado en la documentación del producto, se pueden causar lesiones o, en determinadas circunstancias, incluso la muerte.
3. No ponga el producto sobre aparatos que generen calor (p. ej. radiadores o calefactores). La temperatura ambiente no debe superar la temperatura máxima especificada en la documentación del producto o en la hoja de datos. En caso de sobrecalentamiento del producto, pueden producirse choques eléctricos, incendios y/o lesiones graves con posible consecuencia de muerte.

Instrucciones de seguridad elementales

Seguridad eléctrica

Si no se siguen (o se siguen de modo insuficiente) las indicaciones del fabricante en cuanto a seguridad eléctrica, pueden producirse choques eléctricos, incendios y/o lesiones graves con posible consecuencia de muerte.

1. Antes de la puesta en marcha del producto se deberá comprobar siempre que la tensión preseleccionada en el producto coincida con la de la red de alimentación eléctrica. Si es necesario modificar el ajuste de tensión, también se deberán cambiar en caso dado los fusibles correspondientes del producto.
2. Los productos de la clase de protección I con alimentación móvil y enchufe individual solamente podrán enchufarse a tomas de corriente con contacto de seguridad y con conductor de protección conectado.
3. Queda prohibida la interrupción intencionada del conductor de protección, tanto en la toma de corriente como en el mismo producto. La interrupción puede tener como consecuencia el riesgo de que el producto sea fuente de choques eléctricos. Si se utilizan cables alargadores o regletas de enchufe, deberá garantizarse la realización de un examen regular de los mismos en cuanto a su estado técnico de seguridad.
4. Si el producto no está equipado con un interruptor para desconectarlo de la red, o bien si el interruptor existente no resulta apropiado para la desconexión de la red, el enchufe del cable de conexión se deberá considerar como un dispositivo de desconexión. El dispositivo de desconexión se debe poder alcanzar fácilmente y debe estar siempre bien accesible. Si, p. ej., el enchufe de conexión a la red es el dispositivo de desconexión, la longitud del cable de conexión no debe superar 3 m). Los interruptores selectores o electrónicos no son aptos para el corte de la red eléctrica. Si se integran productos sin interruptor en bastidores o instalaciones, se deberá colocar el interruptor en el nivel de la instalación.
5. No utilice nunca el producto si está dañado el cable de conexión a red. Compruebe regularmente el correcto estado de los cables de conexión a red. Asegúrese, mediante las medidas de protección y de instalación adecuadas, de que el cable de conexión a red no pueda ser dañado o de que nadie pueda ser dañado por él, p. ej. al tropezar o por un choque eléctrico.
6. Solamente está permitido el funcionamiento en redes de alimentación TN/TT aseguradas con fusibles de 16 A como máximo (utilización de fusibles de mayor amperaje solo previa consulta con el grupo de empresas Rohde & Schwarz).
7. Nunca conecte el enchufe en tomas de corriente sucias o llenas de polvo. Introduzca el enchufe por completo y fuertemente en la toma de corriente. La no observación de estas medidas puede provocar chispas, fuego y/o lesiones.
8. No sobrecargue las tomas de corriente, los cables alargadores o las regletas de enchufe ya que esto podría causar fuego o choques eléctricos.
9. En las mediciones en circuitos de corriente con una tensión $U_{\text{eff}} > 30 \text{ V}$ se deberán tomar las medidas apropiadas para impedir cualquier peligro (p. ej. medios de medición adecuados, seguros, limitación de tensión, corte protector, aislamiento etc.).
10. Para la conexión con dispositivos informáticos como un PC o un ordenador industrial, debe comprobarse que éstos cumplan los estándares IEC60950-1/EN60950-1 o IEC61010-1/EN 61010-1 válidos en cada caso.

Instrucciones de seguridad elementales

11. A menos que esté permitido expresamente, no retire nunca la tapa ni componentes de la carcasa mientras el producto esté en servicio. Esto pone a descubierto los cables y componentes eléctricos y puede causar lesiones, fuego o daños en el producto.
12. Si un producto se instala en un lugar fijo, se deberá primero conectar el conductor de protección fijo con el conductor de protección del producto antes de hacer cualquier otra conexión. La instalación y la conexión deberán ser efectuadas por un electricista especializado.
13. En el caso de dispositivos fijos que no estén provistos de fusibles, interruptor automático ni otros mecanismos de seguridad similares, el circuito de alimentación debe estar protegido de modo que todas las personas que puedan acceder al producto, así como el producto mismo, estén a salvo de posibles daños.
14. Todo producto debe estar protegido contra sobretensión (debida p. ej. a una caída del rayo) mediante los correspondientes sistemas de protección. Si no, el personal que lo utilice quedará expuesto al peligro de choque eléctrico.
15. No debe introducirse en los orificios de la caja del aparato ningún objeto que no esté destinado a ello. Esto puede producir cortocircuitos en el producto y/o puede causar choques eléctricos, fuego o lesiones.
16. Salvo indicación contraria, los productos no están impermeabilizados (ver también el capítulo "Estados operativos y posiciones de funcionamiento", punto 1). Por eso es necesario tomar las medidas necesarias para evitar la entrada de líquidos. En caso contrario, existe peligro de choque eléctrico para el usuario o de daños en el producto, que también pueden redundar en peligro para las personas.
17. No utilice el producto en condiciones en las que pueda producirse o ya se hayan producido condensaciones sobre el producto o en el interior de éste, como p. ej. al desplazarlo de un lugar frío a otro caliente. La entrada de agua aumenta el riesgo de choque eléctrico.
18. Antes de la limpieza, desconecte por completo el producto de la alimentación de tensión (p. ej. red de alimentación o batería). Realice la limpieza de los aparatos con un paño suave, que no se deshilache. No utilice bajo ningún concepto productos de limpieza químicos como alcohol, acetona o diluyentes para lacas nitrocelulósicas.

Funcionamiento

1. El uso del producto requiere instrucciones especiales y una alta concentración durante el manejo. Debe asegurarse que las personas que manejen el producto estén a la altura de los requerimientos necesarios en cuanto a aptitudes físicas, psíquicas y emocionales, ya que de otra manera no se pueden excluir lesiones o daños de objetos. El empresario u operador es responsable de seleccionar el personal usuario apto para el manejo del producto.
2. Antes de desplazar o transportar el producto, lea y tenga en cuenta el capítulo "Transporte".
3. Como con todo producto de fabricación industrial no puede quedar excluida en general la posibilidad de que se produzcan alergias provocadas por algunos materiales empleados —los llamados alérgenos (p. ej. el níquel)—. Si durante el manejo de productos Rohde & Schwarz se producen reacciones alérgicas, como p. ej. irritaciones cutáneas, estornudos continuos, enrojecimiento de la conjuntiva o dificultades respiratorias, debe avisarse inmediatamente a un médico para investigar las causas y evitar cualquier molestia o daño a la salud.
4. Antes de la manipulación mecánica y/o térmica o el desmontaje del producto, debe tenerse en cuenta imprescindiblemente el capítulo "Eliminación/protección del medio ambiente", punto 1.

Instrucciones de seguridad elementales

5. Ciertos productos, como p. ej. las instalaciones de radiocomunicación RF, pueden a causa de su función natural, emitir una radiación electromagnética aumentada. Deben tomarse todas las medidas necesarias para la protección de las mujeres embarazadas. También las personas con marcapasos pueden correr peligro a causa de la radiación electromagnética. El empresario/operador tiene la obligación de evaluar y señalar las áreas de trabajo en las que exista un riesgo elevado de exposición a radiaciones.
6. Tenga en cuenta que en caso de incendio pueden desprenderse del producto sustancias tóxicas (gases, líquidos etc.) que pueden generar daños a la salud. Por eso, en caso de incendio deben usarse medidas adecuadas, como p. ej. máscaras antigás e indumentaria de protección.
7. Los productos con láser están provistos de indicaciones de advertencia normalizadas en función de la clase de láser del que se trate. Los rayos láser pueden provocar daños de tipo biológico a causa de las propiedades de su radiación y debido a su concentración extrema de potencia electromagnética. En caso de que un producto Rohde & Schwarz contenga un producto láser (p. ej. un lector de CD/DVD), no debe usarse ninguna otra configuración o función aparte de las descritas en la documentación del producto, a fin de evitar lesiones (p. ej. debidas a irradiación láser).
8. Clases de compatibilidad electromagnética (conforme a EN 55011 / CISPR 11; y en analogía con EN 55022 / CISPR 22, EN 55032 / CISPR 32)
 - Aparato de clase A:
Aparato adecuado para su uso en todos los entornos excepto en los residenciales y en aquellos conectados directamente a una red de distribución de baja tensión que suministra corriente a edificios residenciales.
Nota: Los aparatos de clase A están destinados al uso en entornos industriales. Estos aparatos pueden causar perturbaciones radioeléctricas en entornos residenciales debido a posibles perturbaciones guiadas o radiadas. En este caso, se le podrá solicitar al operador que tome las medidas adecuadas para eliminar estas perturbaciones.
 - Aparato de clase B:
Aparato adecuado para su uso en entornos residenciales, así como en aquellos conectados directamente a una red de distribución de baja tensión que suministra corriente a edificios residenciales.

Reparación y mantenimiento

1. El producto solamente debe ser abierto por personal especializado con autorización para ello. Antes de manipular el producto o abrirlo, es obligatorio desconectarlo de la tensión de alimentación, para evitar toda posibilidad de choque eléctrico.
2. El ajuste, el cambio de partes, el mantenimiento y la reparación deberán ser efectuadas solamente por electricistas autorizados por Rohde & Schwarz. Si se reponen partes con importancia para los aspectos de seguridad (p. ej. el enchufe, los transformadores o los fusibles), solamente podrán ser sustituidos por partes originales. Después de cada cambio de partes relevantes para la seguridad deberá realizarse un control de seguridad (control a primera vista, control del conductor de protección, medición de resistencia de aislamiento, medición de la corriente de fuga, control de funcionamiento). Con esto queda garantizada la seguridad del producto.

Instrucciones de seguridad elementales

Baterías y acumuladores o celdas

Si no se siguen (o se siguen de modo insuficiente) las indicaciones en cuanto a las baterías y acumuladores o celdas, pueden producirse explosiones, incendios y/o lesiones graves con posible consecuencia de muerte. El manejo de baterías y acumuladores con electrolitos alcalinos (p. ej. celdas de litio) debe seguir el estándar EN 62133.

1. No deben desmontarse, abrirse ni triturarse las celdas.
2. Las celdas o baterías no deben someterse a calor ni fuego. Debe evitarse el almacenamiento a la luz directa del sol. Las celdas y baterías deben mantenerse limpias y secas. Limpiar las conexiones sucias con un paño seco y limpio.
3. Las celdas o baterías no deben cortocircuitarse. Es peligroso almacenar las celdas o baterías en estuches o cajones en cuyo interior puedan cortocircuitarse por contacto recíproco o por contacto con otros materiales conductores. No deben extraerse las celdas o baterías de sus embalajes originales hasta el momento en que vayan a utilizarse.
4. Las celdas o baterías no deben someterse a impactos mecánicos fuertes indebidos.
5. En caso de falta de estanqueidad de una celda, el líquido vertido no debe entrar en contacto con la piel ni los ojos. Si se produce contacto, lavar con agua abundante la zona afectada y avisar a un médico.
6. En caso de cambio o recarga inadecuados, las celdas o baterías que contienen electrolitos alcalinos (p. ej. las celdas de litio) pueden explotar. Para garantizar la seguridad del producto, las celdas o baterías solo deben ser sustituidas por el tipo Rohde & Schwarz correspondiente (ver lista de recambios).
7. Las baterías y celdas deben reciclarse y no deben tirarse a la basura doméstica. Las baterías o acumuladores que contienen plomo, mercurio o cadmio deben tratarse como residuos especiales. Respete en esta relación las normas nacionales de eliminación y reciclaje.
8. En caso de devolver baterías de litio a las filiales de Rohde & Schwarz, debe cumplirse las normativas sobre los modos de transporte (IATA-DGR, código IMDG, ADR, RID).

Transporte

1. El producto puede tener un peso elevado. Por eso es necesario desplazarlo o transportarlo con precaución y, si es necesario, usando un sistema de elevación adecuado (p. ej. una carretilla elevadora), a fin de evitar lesiones en la espalda u otros daños personales.
2. Las asas instaladas en los productos sirven solamente de ayuda para el transporte del producto por personas. Por eso no está permitido utilizar las asas para la sujeción en o sobre medios de transporte como p. ej. grúas, carretillas elevadoras de horquilla, carros etc. Es responsabilidad suya fijar los productos de manera segura a los medios de transporte o elevación. Para evitar daños personales o daños en el producto, siga las instrucciones de seguridad del fabricante del medio de transporte o elevación utilizado.
3. Si se utiliza el producto dentro de un vehículo, recae de manera exclusiva en el conductor la responsabilidad de conducir el vehículo de manera segura y adecuada. El fabricante no asumirá ninguna responsabilidad por accidentes o colisiones. No utilice nunca el producto dentro de un vehículo en movimiento si esto pudiera distraer al conductor. Asegure el producto dentro del vehículo debidamente para evitar, en caso de un accidente, lesiones u otra clase de daños.

Instrucciones de seguridad elementales

Eliminación/protección del medio ambiente

1. Los dispositivos marcados contienen una batería o un acumulador que no se debe desechar con los residuos domésticos sin clasificar, sino que debe ser recogido por separado. La eliminación se debe efectuar exclusivamente a través de un punto de recogida apropiado o del servicio de atención al cliente de Rohde & Schwarz.
2. Los dispositivos eléctricos usados no se deben desechar con los residuos domésticos sin clasificar, sino que deben ser recogidos por separado.
Rohde & Schwarz GmbH & Co.KG ha elaborado un concepto de eliminación de residuos y asume plenamente los deberes de recogida y eliminación para los fabricantes dentro de la UE. Para desechar el producto de manera respetuosa con el medio ambiente, diríjase a su servicio de atención al cliente de Rohde & Schwarz.
3. Si se trabaja de manera mecánica y/o térmica cualquier producto o componente más allá del funcionamiento previsto, pueden liberarse sustancias peligrosas (p. ej. plomo, berilio o níquel). Por eso el producto solo debe ser desmontado por personal especializado con formación adecuada. Un desmontaje inadecuado puede ocasionar daños para la salud. Se deben tener en cuenta las directivas nacionales referentes a la eliminación de residuos.
4. En caso de que durante el trato del producto se formen sustancias peligrosas o combustibles que deban tratarse como residuos especiales (p. ej. refrigerantes o aceites de motor con intervalos de cambio definidos), deben tenerse en cuenta las indicaciones de seguridad del fabricante de dichas sustancias y las normas regionales de eliminación de residuos. Tenga en cuenta también en caso necesario las indicaciones de seguridad especiales contenidas en la documentación del producto. La eliminación incorrecta de sustancias peligrosas o combustibles puede causar daños a la salud o daños al medio ambiente.

Se puede encontrar más información sobre la protección del medio ambiente en la página web de Rohde & Schwarz.

Customer Support

Technical support – where and when you need it

For quick, expert help with any Rohde & Schwarz product, contact our customer support center. A team of highly qualified engineers provides support and works with you to find a solution to your query on any aspect of the operation, programming or applications of Rohde & Schwarz products.

Contact information

Contact our customer support center at www.rohde-schwarz.com/support, or follow this QR code:



QR code to the Rohde & Schwarz support page

Contents

1 Introduction.....	5
1.1 Key Features.....	5
1.2 For Your Safety.....	5
1.3 Documentation Overview.....	6
2 Startup.....	8
2.1 Description of the Front View.....	9
2.2 Description of the Rear Panel.....	19
2.3 Putting into Operation.....	22
2.4 Function Check.....	30
2.5 Presets.....	30
2.6 Windows Operating System.....	32
2.7 Connecting External Keyboard and Mouse.....	34
2.8 Connecting an External Monitor.....	35
2.9 Installing Options.....	38
2.10 Connect R&S UPP to a Network (LAN).....	38
2.11 Firmware Update.....	58
2.12 Windows XP Recovery and Backup.....	59
2.13 Windows 7 Recovery and Backup.....	64
3 Getting Started.....	69
3.1 Introduction - Getting Started.....	69
3.2 Important Information for Measurements.....	70
3.3 Brief Introduction to Operation.....	72
3.4 Introduction to Instrument Operation Using Examples.....	91
3.5 Loading Predefined Instrument Setups.....	112

4 Manual Operation.....	114
4.1 Introduction - Manual Operation.....	114
4.2 Functional Division of the Audio Analyzer.....	115
4.3 General Information on Operation.....	122
4.4 The Display.....	125
4.5 Panels.....	129
4.6 Settings on the Audio Analyzer.....	135
4.7 Settings in the Panels.....	136
4.8 Measurement Displays.....	150
4.9 Settings in the Menu Bar.....	182
4.10 Settings on the Toolbar.....	190
4.11 Settings in the Operating System.....	191
4.12 Auxiliaries Panel.....	191
4.13 Rapid Deactivation of Outputs.....	193
4.14 Help System.....	193
4.15 File Management.....	195
4.16 Manual Remote Operation.....	197
4.17 Units.....	199
4.18 Overview of Keys.....	204
4.19 Overview of Panels and Measurement Displays (Graphical Windows).....	207
4.20 Overview of Status Messages.....	211
Index.....	213

1 Introduction

High measurement speed, parallel signal processing in multichannel applications, and high reliability in continuous operation are vital requirements to be met by audio analyzers for use in production. If a cost-efficient instrument for system use is what you need, the solution is the R&S UPP audio analyzer.

1.1 Key Features

- Suitable for all interfaces: analog, digital and combined
- Parallel measurements on up to eight channels
- Up to 80 kHz bandwidth and 200 kHz sampling rate
- Powerful and fast
- All test signals and measurement functions in a single box

1.2 For Your Safety

The R&S UPP is designated for use in industrial, administrative and laboratory environments. Use the R&S UPP only for its designated purpose. Observe the operating conditions and performance limits stated in the data sheet.

The product documentation helps you to use the R&S UPP safely and efficiently. Keep the product documentation in a safe place and pass it on to the subsequent users.

Safety information is part of the product documentation. It warns you about the potential dangers and gives instructions how to prevent personal injury or damage caused by dangerous situations. Safety information is provided as follows:

- In the "Basic Safety Instructions", safety issues are grouped according to subjects. For example, one subject is electrical safety. The "Basic Safety Instructions" are delivered with the R&S UPP in different languages in print.
- Throughout the documentation, safety instructions are provided when you need to take care during setup or operation. Always read the safety instructions carefully. Make sure to comply fully with them. Do not take risks and do

not underestimate the potential danger of small details such as a damaged power cable.

1.3 Documentation Overview

This section provides an overview of the R&S UPP user documentation and on how to access it.

Included in delivery

- **Getting started and basic safety instructions**
The printed getting started manual and the basic safety instruction are delivered together with the instrument.
The getting started describes how to set up and start working with the instrument, it includes basic operations and general information, e.g. safety instructions,
- **User manual** for the instrument and its options
The user manual is provided as context-sensitive online-help on the instrument.
In addition to the chapters of the quick start guide, the user manual contains the description of all instrument functions and the remote control of the instrument. Furthermore, it features notes for the preventive maintenance of the R&S UPP and for locating errors based on the warnings and error messages issued by the instrument.

As download on the Internet via the download section of the instrument page

- **Getting started**
In addition to the printed manual, the getting started is provided as download on the Internet (PDF format).
- **User manual** for the instrument and its options
In addition to the online help, the user manual is provided as download (PDF format) and as online manual (HTML format) on the Internet.
- **Instrument security procedures**
The instrument security procedures manual deals with security issues when working with the R&S UPP in secure areas.
- **Data sheet and brochure**

The data sheet contains the technical specifications of the R&S UPP. It lists the options, their order numbers and optional accessories. The brochure provides an overview of the instrument and deals with the specific characteristics.

- **Release notes and open source acknowledgment**

Release notes and open source acknowledgment are provided together with the corresponding firmware.

The release notes describe the installation of the firmware, new and improved functions, problems solved and last-minute changes to the documentation.

The corresponding firmware version can be seen on the cover sheet of the release notes.

The open source acknowledgment document provides verbatim license texts of the used open source software. The acknowledgment is also provided on the instrument.

- **Application notes**

Application notes deal with special applications or background information on particular topics.

Link to the product page on the Internet; www.rohde-schwarz.com/product/upp.html.

As download for registered customers on GLORIS, the Global Rohde & Schwarz Information System.

- **Service manual**

The service manual contains all the necessary information to maintain the R&S UPP by replacing modules and to expand its functionality by installing options.

Link to GLORIS: gloris.rohde-schwarz.com.

2 Startup

The R&S UPP audio analyzer is available in three models. The 8-channel instrument R&S UPP 800, the 4-channel instrument R&S UPP 400 and the 2-channel instrument R&S UPP 200. The instruments are offered without display, without front panel controls and without CD/DVD drive. The three model variants are identical with respect to functions except for the number of channels and are handled together in the description.

This chapter describes the controls and ports of the R&S audio analyzer UPP based on the front and rear view and shows how to put the instrument into operation. It also describes the connection of peripherals such as printer, keyboard, mouse and monitor. Specifications for the interfaces can be found in the data sheet.

The introduction to [Chapter 3.1, "Introduction - Getting Started"](#), on page 69 provides an overview of the functions and the operating concept of the audio analyzer. Detailed operating instructions and an overview of the menus are provided in [Chapter 4.1, "Introduction - Manual Operation"](#), on page 114.

The instrument help (and the PDF and online manual on the Internet) comprise the entire manual: The individual menus and functions of the instrument including the associated remote-control commands are explained in detail in chapter "Instrument Functions". Information on remote control of the instrument is provided in the chapters "Remote Control - Fundamentals" and "Remote Control - Commands Description". A detailed description of the instrument interfaces can be found in the chapter "Maintenance and Instrument Interfaces".



The audio analyzer has a Windows operating system. No special knowledge of the operating system used is required for operating the instrument. Basic PC knowledge, such as what a file, a directory, etc. is, or how data is transferred using Windows Explorer® is assumed and, therefore, not discussed in any detail.

The R&S UPP audio analyzer is operated via an external keyboard or mouse. Operation follows the same basic rules which apply to other Windows programs in use today. It is also assumed that users are familiar with these basic rules. This information is therefore not specified in detail here.

2.1 Description of the Front View

This section provides an overview of the control elements and connectors on the front of the R&S UPP. Specifications for the connectors can be found in the data sheet.

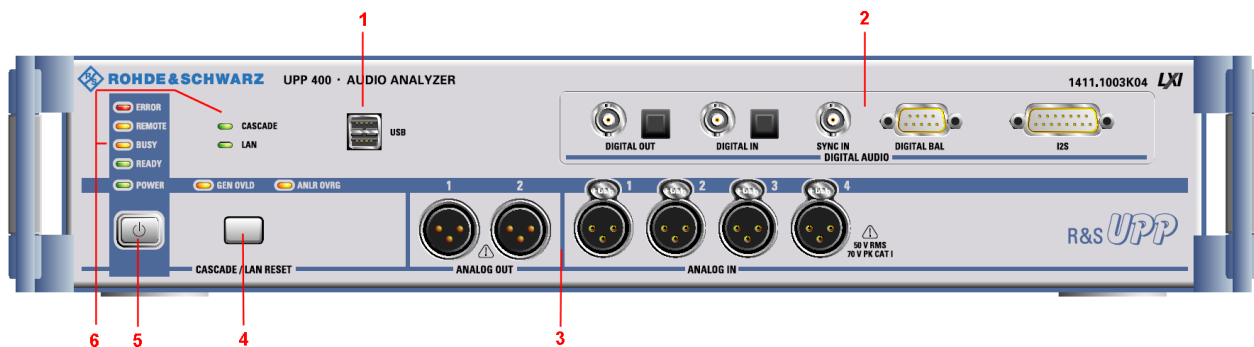

Figure 2-1: Front view of R&S UPP 400 (4-channel instrument), also representative for R&S UPP 200 (2-channel instrument) and R&S UPP 800 (8-channel instrument) with installed R&S UPP-B2 option (digital audio interfaces).

- 1 = USB Connectors
- 2 = Digital audio/HDMI interfaces or multichannel generator
- 3 = Analog Audio Interfaces
- 4 = LAN RESET button
- 5 = STANDBY pushbutton
- 6 = STATUS LEDs

2.1.1 USB Connectors



USB 2.0 ports (Universal Serial Bus) of type A (host USB).

- Connecting peripherals such as mouse, keyboard, printer
- Connecting a mass storage device such as a USB stick for transferring files

There are additional USB interfaces on the rear of the instrument.

2.1.2 Digital Audio Interfaces

Inputs and outputs for connecting digital consumer instruments and professional studio equipment.

Description of the Front View

**Note**

These interfaces are only available if the R&S UPP-B2 option (digital audio interfaces) is installed!

[DIGITAL OUT]

BNC output for the SPDIF or AES/EBU format acc. to EIAJ CP-340 and optical output acc. to the TOSLINK system. A double-shielded BNC cable must be used to maintain EMC Class B.

[DIGITAL IN]

BNC input for the SPDIF or AES/EBU format acc. to EIAJ CP-340 and optical input acc. to the TOSLINK system. A double-shielded BNC cable must be used to maintain EMC Class B.

[SYNC IN]

BNC synchronization input for the generator instrument "Digital Audio" for the external synchronization options "Sync To" = "Ext DARS", "Ext Clock" or "Ext Inv Clock", and for the generator instrument "I2S" for "Sync To" = "Extern Masterclk" or "Ext Wordclk". A double-shielded BNC cable must be used to maintain EMC Class B.

[DIGITAL BAL]

9-pin D-Sub connector for connecting the symmetrical input and output signals for the SPDIF or AES/EBU format acc. to EIAJ CP-340. The pin assignment is described in the operating manual on the documentation CD. The R&S UPP-Z2 cable option must be used to maintain EMC Class B.

[I2S]

25-contact D-Sub connector for connecting the input and output lines of the I²S interfaces. The pin assignment is described in the operating manual on the documentation CD. The R&S UPP-Z3 cable option must be used to maintain EMC Class B.

2.1.3 Digital Audio/HDMI Interfaces

Inputs and outputs for connecting digital consumer instruments and professional studio equipment.

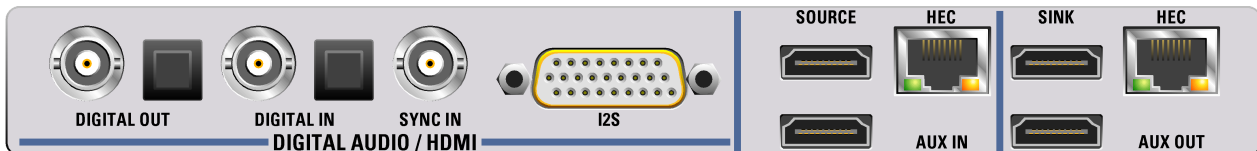

Note

These interfaces are only available if the R&S UPP-B4 option (HDMI and digital audio interfaces) is installed!

[DIGITAL OUT]

BNC output for the SPDIF or AES/EBU format acc. to EIAJ CP-340 and optical output acc. to the TOSLINK system. A double-shielded BNC cable must be used to maintain EMC Class A.

[DIGITAL IN]

BNC input for the SPDIF or AES/EBU format acc. to EIAJ CP-340 and optical input acc. to the TOSLINK system. A double-shielded BNC cable must be used to maintain EMC Class A.

[SYNC IN]

BNC synchronization input for the generator instrument "Digital Audio" for the external synchronization options "Sync To" = "Ext DARS", "Ext Clock" or "Ext Inv Clock", and for the generator instrument "I2S" for "Sync To" = "Extern Masterclk" or "Ext Wordclk". A double-shielded BNC cable must be used to maintain EMC Class A.

[I2S]

26-contact D-Sub connector for connecting the input and output lines of the I²S interfaces. The pin assignment is described in the operating manual on the documentation CD. The R&S UPP-Z4 cable option must be used to maintain EMC Class A.

[SOURCE]

HDMI 1.4 generator socket with HEAC support. Video formats can be generated internally or supplied via the AUX IN socket. The audio signals are always generated inside the device. To maintain EMC Class A, a suitable HDMI cable with multiple shielding and two ferrites (e.g. Würth Elektronik split ferrite 722-712-21) as well as a maximum length of 3 m is to be used.

[AUX IN]

Input socket for feeding an externally generated video signal. The video data, together with all the HDMI protocol data as well as info frames with the exception of the internally generated audio info frame, are combined with the internally generated audio data and output via the Source socket. To maintain EMC Class A, a suitable HDMI cable with multiple shielding and two ferrites (e.g. Würth Elektronik split ferrite 722-712-21) as well as a maximum length of 3 m is to be used.

[HEC (Source)]

Decoupling of the Home Ethernet Channel at the HEC RJ-45 socket. The figure below shows a typical application scenario. The HDMI 1.4 implementation in the R&S UPP supports the Audio Return Channel (ARC) as well as the Home Ethernet Channel (HEC). Both signals are transferred together using a dedicated wire pair and referred to as HEAC. HDMI 1.4-compliant receiver and transmitter modules are capable of feeding and decoupling these two signals. An HDMI 1.4-compliant cable and an HDMI 1.4-compliant receiver with HEC support can be used to test its Ethernet functionality. A double-shielded Ethernet cable must be used to maintain EMC Class A.

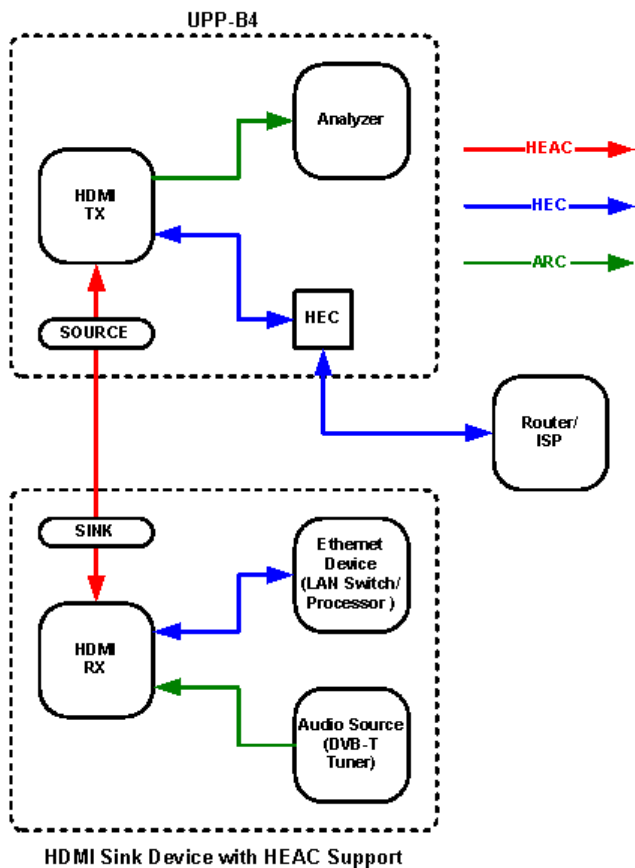

[SINK]

HDMI 1.4 analyzer socket with HEAC support. Various measurement functions are available for the audio and video signals fed in at this interface. To maintain EMC Class A, a suitable HDMI cable with multiple shielding and two ferrites (e.g. Würth Elektronik split ferrite 722-712-21) as well as a maximum length of 3 m is to be used.

[AUX OUT]

The audio and video signals fed in at the HDMI Sink socket are connected through 1:1 to the AUX OUT output. A display device can be connected to this HDMI source to display the user interface of an AV receiver or a Blu-ray player. To maintain EMC Class A, a suitable HDMI cable with multiple shielding and two ferrites (e.g. Würth Elektronik split ferrite 722-712-21) as well as a maximum length of 3 m is to be used.

[HEC (Sink)]

Decoupling of the Home Ethernet Channel at the HEC RJ-45 socket. The figure below shows a typical application scenario. The HDMI 1.4 implementation in the R&S UPP supports the Audio Return Channel (ARC) as well as the Home Ethernet Channel (HEC). Both signals are transferred together using a dedicated wire pair and referred to as HEAC. HDMI 1.4-compliant receiver and transmitter modules are capable of feeding and decoupling these two signals. An HDMI 1.4-compliant cable and an HDMI 1.4-compliant source device with HEC support can be used to test its Ethernet functionality. A double-shielded Ethernet cable must be used to maintain EMC Class A.

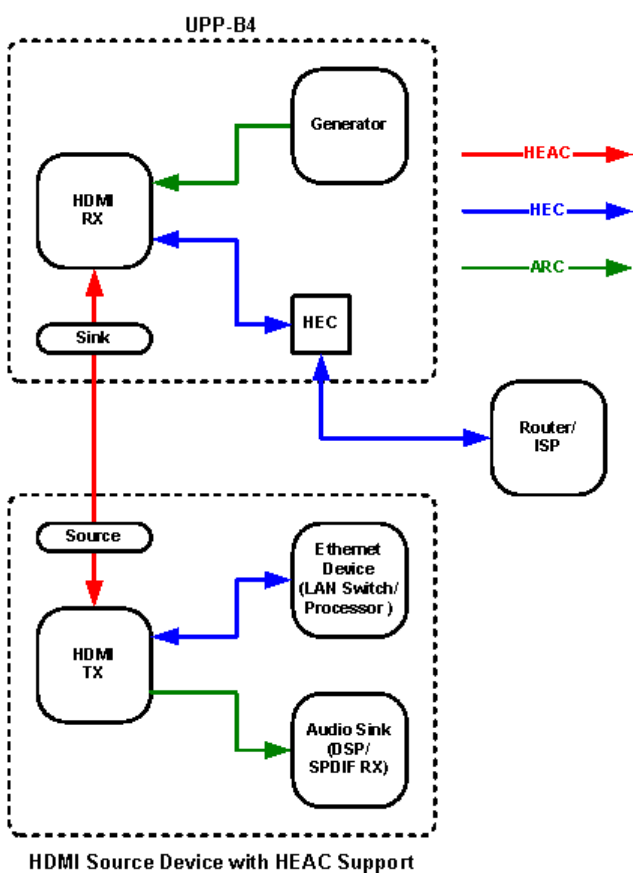

2.1.4 Multi-channel generator

Generator with analog and digital outputs.



**Note**

This interface is only available if the R&S UPP-B8 option (multichannel audio generator) is installed!

[ANALOG OUT]

Eight analog outputs brought out on the pins of a 25-pin D-Sub socket.

As an accessory for the R&S UPP-B8 option (multichannel audio generator), a breakout cable with a 25-pin D-Sub connector on the one end and eight XLR connectors on the other end is available (R&S UP-Z8A option; refer to data sheet for the order number).

[DIGITAL OUT]

Eight outputs in S/P DIF format in accordance with IEC 60958 (Unbal), which are brought out to a 9-pin D-Sub socket.

As an accessory for the R&S UPP-B8 option (multichannel audio generator), a breakout cable with a 9-pin D-Sub connector on the one end and five XLR connectors on the other end is available (R&S UP-Z8D option; refer to data sheet for the order number).

2.1.5 Analog Audio Interfaces

Output and input connectors (XLR) of analog generator and analyzer.



Figure 2-2: R&S UPP variants from top to bottom: R&S UPP 800, R&S UPP 400, R&S UPP 200

NOTICE**Damage to the instrument**

The instrument complies with measuring category I; make sure that the input voltage at the sockets of the analog analyzers does not exceed 50 V (RMS, sine wave) and 70 V (peak value).

Do not use the instrument in measuring categories II, III and IV.

Explanation: Measuring circuits as defined in section 6.7.4 of EN61010-1: Measuring category I is intended for measurements on circuits which are not connected to the high-voltage current system.

[ANALOG OUT 1 / 2]

Two-channel generator signal at XLR connectors

[Analog IN 1 / 2 / 3 / 4 / 5 / 6 / 7 / 8]

Depending on the R&S UPP variant 2, 4 or 8, analog XLR sockets as measurement inputs

2.1.6 LAN RESET button**[CASCADE / LAN RESET]**

The LAN RESET button has three functions:

- Configuration of an R&S UPP cascade:
A short key press combines several R&S UPP instruments into one measurement unit with more than 8 analog audio channels.
- Resets the LXI LAN default settings:
Pressing and holding the key > 10 s sets the LXI LAN default settings to "DHCP + AutoIP / VXI-11 discovery on" and "restart of the device"
- Master PRESET:
With the Master PRESET, you can easily get out of an unsuitable screen and monitor configuration and back to an operable instrument: Switch the instrument off and on again. During the software start, the ANLR OVRG-LED is illuminated briefly in yellow. As soon as this LED is illuminated in yellow, press the LAN RESET button briefly. The LED flashes for confirmation. Within the

next 5 seconds, press the LAN RESET pushbutton again briefly. The Master PRESET is now carried out and forces a switchover to the external monitor with a screen resolution of 1024 x 768 pixels and the factory default settings.

2.1.7 STANDBY pushbutton



Used to switch the instrument alternately on and off. This requires that the power switch on the rear side of the instrument is switched on. If the instrument is switched on, POWER LED is green; if the instrument is switched off but in standby mode, POWER LED is yellow.

⚠ WARNING

Risk of electric shock

In standby mode, the instrument is supplied by the AC supply voltage!
The instrument must be set up in such a way that operation of the power switch is not obstructed.

2.1.8 Status LEDs



[ERROR]

- **LED is lit (not flashing):** The instrument detected an error during the measurement
- **LED is flashing:** The instrument detected an error during the configuration of the cascading

[REMOTE]

The instrument is controlled remotely

[BUSY]

The LED is on as long as the measurement is running

[READY]

The instrument is ready for operation and can be controlled manually or remotely

[POWER]

- **LED is yellow:** The instrument is in standby mode
- **LED is green:** The instrument is switched on

[CASCADE]

- **LED is lit (not flashing):** The instrument is in cascading mode
- **LED is flashing:** The instrument is in the configuration phase of a cascading

[LAN]

The instrument is integrated in a local network

[GEN OVLD]

- **LED is yellow:** The outputs of the audio analyzer have been deactivated using the "Output OFF" function.
- **LED is red:** The generator has been switched off **at high impedance** because an external feed at pin 2 or 3 has caused a voltage of ≥ 12 V peak to be applied to instrument ground.

The outputs can be switched on again, either

- by pressing CTRL+F12 on the external keyboard,
- switching the instrument off/on with the standby mode pushbutton or
- transmitting the SCPI command "OUTPut ON".

[ANLR OVRG]

- **LED is red:** One of the analog audio inputs is overloaded. The level of the present signal is too high for the current band. Signals outside the IF "Bandwidth" can result in overranging.
- **LED is yellow:** One of the analog audio inputs is overloaded and could result in an inaccurate or unstable measurement result

2.2 Description of the Rear Panel

This section provides an overview of the connectors at the rear panel of the R&S UPP. Specifications for the connectors can be found in the data sheet.

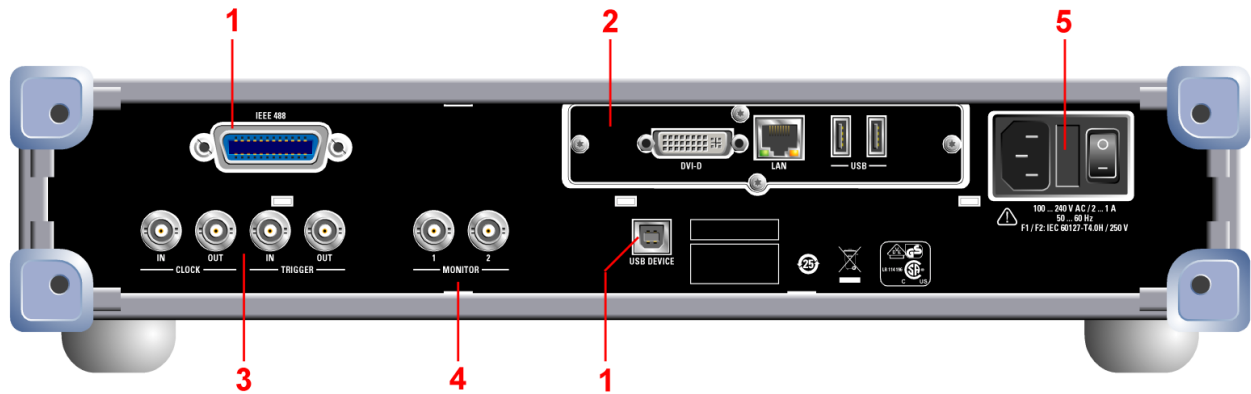
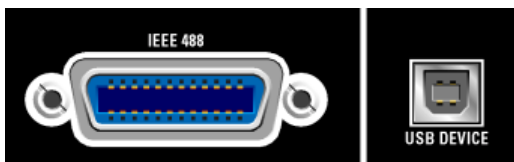

Figure 2-3: Rear view of the R&S UPP

- 1 = Remote-control connectors
- 2 = PC interfaces
- 3 = Cascading connections
- 4 = BNC monitor outputs
- 5 = AC supply voltage connector

2.2.1 Remote-control connectors



[IEEE 488]

IEC/IEEE-bus connector (IEC 625/IEEE 488) for remote control of the instrument

[USB DEVICE]

USB 2.0 device connector for remote control of the instrument

2.2.2 PC interfaces

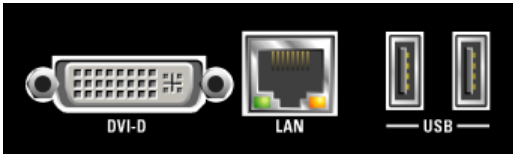

[DVI-D]

DVI-D socket for connecting an external monitor to the instrument. It is recommended to use a very well shielded cable with ferrite sleeves.

[LAN]

LAN interface for

- integrating the audio analyzer in a network, e.g. for cascading several UPP instruments into one measurement unit with more than 8 analog audio channels
- Remote control of audio analyzer via remote desktop from a remote computer
- Remote control of audio analyzer via SCPI commands from a controller

[USB]

USB 2.0 ports (Universal Serial Bus) of type A (host USB).

- Connecting peripherals such as mouse, keyboard, printer
- Connecting a mass storage device such as a USB stick for transferring files

There are additional USB interfaces on the front of the instrument.

2.2.3 Cascading Connections

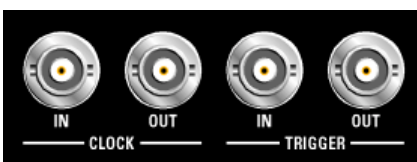

The use of a double-shielded BNC cable is recommended as connecting cable, whether for cascading devices or connecting a device under test.

[CLOCK IN]

Required for cascading and must be connected with CLOCK OUT of the previous instrument

[CLOCK OUT]

Required for cascading and must be connected with CLOCK IN of the next instrument

[TRIGGER IN]

This connector is required for cascading and must be connected with TRIGGER OUT of the previous instrument

[TRIGGER OUT]

- Required for cascading and must be connected with TRIGGER IN of the next instrument
- The trigger output level is 3.3 V
- Can be used for connecting to a device under test.

2.2.4 BNC monitor outputs



The instrument settings determine which signal is present at these BNC sockets:

- The input signal (maximum ± 5 V peak)
- The filtered signal from the analyzer (maximum ± 5 V peak)
- Starting with serial numbers 120100, 140100, 180100, a DC level (maximum ± 5 V)

The maximum output level is limited to ± 5 V peak

2.2.5 AC Supply Voltage Connector

AC supply voltage connector with integrated power switch





Shutting down the operating system

It is urgently recommended to shut down the operating system first before switching off the instrument via the power switch by switching off the instrument with the standby mode pushbutton (POWER LED should be orange before the shutdown).

[AC Supply Voltage Connector]

If the instrument is connected to the AC supply voltage, it automatically adjusts to the AC supply voltage (see the labeling for the voltage range). It is not necessary to manually adjust the instrument for a specific voltage or to change the fuse!

[Fuse carrier]

The fuse holder contains two fuses and is located between the AC supply voltage connector and the power switch. Both fuses protect the circuit.

[Power switch]

The power switch has two positions:

- 0: The instrument is disconnected from the AC supply
- 1: The instrument is supplied by the AC supply voltage. Depending on the activation of the standby mode pushbutton, the instrument is either in standby mode (POWER LED is yellow) or it is switched on (POWER LED is green)

2.3 Putting into Operation

The following section describes how to put the instrument into operation, connect external devices such as printer and monitor, and a connection of the audio analyzer with a network. It contains general safety instructions for instrument operation.

For information about installing options, see [Chapter 2.9, "Installing Options"](#), on page 38.

For information about the firmware update, see [Chapter 2.11, "Firmware Update"](#), on page 58.

⚠ CAUTION**Safety precautions**

Be absolutely sure to follow the instructions in the sections below to prevent injury to people or damage to the instrument. This is particularly important if the instrument is used for the first time. The general safety instructions at the beginning of this manual must also be observed.

2.3.1 Unpacking the instrument

The instrument is delivered together with the accessories in one box. Proceed as follows to unpack its contents:

1. Remove the instrument from its packaging and check the shipment for completeness using the shipping document and the accessory lists for the various items.
2. First, pull off the protective plastic pads from the rear feet of the instrument and then from the front handles.
3. Remove the protective cover made of corrugated board from the rear of the instrument.
4. Carefully unthread the corrugated cardboard cover at the front that protects the instrument handles and remove it.
5. Check the instrument for any damage. If there is damage, immediately contact the carrier who delivered the instrument. In this case, do not discard the box and packaging material.

**Packaging material**

It is recommended to retain the packaging. It is advisable to keep the original packing material in order to prevent control elements and connectors from being damaged in case the instrument is to be transported or shipped at a later date.

2.3.2 Setting Up the Instrument

The instrument is intended for indoor use. It can either be set up as a separate unit or mounted in a 19" rack.

The following ambient conditions at the location must be ensured:

- The ambient temperature must comply with the range specified in the data sheet.
- All fan openings must be clear, and the airflow at the openings of the side walls must not be impeded. The distance to the wall must be at least 10 cm.

NOTICE

Possible damage from electrostatic discharge



Electrical discharges can damage components of the instrument or a connected device under test.

For this reason, the instrument may be operated only at a workplace that is protected against electrostatic discharge.

The following methods can be used separately or in combination to protect against electrostatic discharges:

- Protective armband with grounding cable
- Conductive floor covering combined with use of a heel grounder

NOTICE**EMI Suppression**

To suppress electromagnetic interference (EMI), the instrument may be operated only if it is closed and all covers are in place. The EMC class is listed on the data sheet.

The following conditions must be maintained to avoid interference:

- Use suitable double-shielded cables that are no longer than 3 m.
- Use only USB cables that are no longer than 1 m.
- Use only USB devices that adhere to the permissible EMC values.
- Terminate the outputs and cables with 50 Ω .
- Use only the cables R&S UP-Z2, R&S UP-Z3 and R&S UP-Z4 for the digital interfaces.
- Use the cable R&S UP-Z8A for the analog interface of option R&S UPP-B8, and cable R&S UP-Z8D for the digital interface.
- Use only doubled shielded CAT6 or CAT7 cables for the LAN interface.

2.3.2.1 Separate installation

The R&S UPP can be set up on a level surface in horizontal position and with unfolded instrument feet.

⚠ CAUTION**Risk of injury with unfolded instrument feet**

The instrument feet can suddenly fold back if the instrument is being moved or the feet are not completely folded out. This can lead to personal injuries or damage to the instrument.

Instrument stability, and thus safe operation, is only ensured when the instrument's feet are completely folded out. Do not move the instrument and avoid performing work under it when the feet are folded out. Secure the instruments from slipping (e.g. by locking the instrument feet to the top of the front-panel frame).

If excessive loads are applied, the feet might break. The uniformly applied load to the feet when folded out must not exceed 500 N (including the weight of the instrument itself along with any equipment set on top of it).

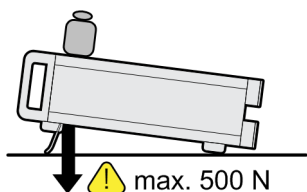
**2.3.2.2 Rack installation**

A rack adapter (refer to data sheet for Order No.) is required for installation in a 19" rack. The mounting instructions are supplied with the adapter.

NOTICE**Possible damage to the instrument from overheating**

Restricted airflow at the side wall openings can cause the instrument to overheat.

To ensure sufficient air supply, all fan openings must be clear and the air-flow at the openings of the side walls must not be impeded. The distance to the wall must be at least 10 cm.

2.3.3 Connecting the R&S UPP to the AC Supply

NOTICE

Possible damage to the instrument

Before connecting and switching on the instrument, observe the following items to avoid any damage to the instrument:

- The tube for the housing has to be attached and screwed in place.
- The ventilation openings must be clear; ensure that air can freely exit at the holes on the sides. The minimum distance to the wall should therefore be at least 10 cm.
- The instrument must be dry.
- The instrument should only be operated in the horizontal position on an even surface.
- The ambient temperature must not exceed the range specified in the data sheet.
- It must be ensured that none of the voltage levels at the inputs exceed permissible limits.
- The instrument complies with measuring category I; make sure that the input voltage at the connectors of the analog analyzers does not exceed 50 V (effective, sinusoidal) and 70 V (peak value). Do not use the instrument in measuring categories II, III and IV.

Explanation:

Measuring circuits as defined in section 6.7.4 of EN61010-1

Measuring category I is intended for measurements on circuits which are not connected to the high-voltage current system.

- The outputs of the instrument should not be overloaded and correct polarity must be ensured.

When the instrument is connected to an AC supply, it automatically adjusts to the AC supply voltage (see the labeling for the voltage range). It is not necessary to manually adjust the instrument for a specific voltage or to change the fuse!

2.3.3.1 Switching on the Instrument

1. Connect the audio analyzer to the AC supply by means of the supplied power cable.

The R&S UPP is in compliance with safety class EN61010-1, it should only be connected to a socket with grounding contact.

The power switch has two positions:

- 0: The instrument is disconnected from the AC supply
- 1: The instrument is supplied by the AC supply voltage. The boot process starts if an instrument that has been switched off is switched on using the power switch. Depending on the activation of the standby mode pushbutton, the instrument is either in standby mode (POWER LED is yellow) or it is switched on (POWER LED is green)



2. The button on the front alternates between switching the instrument on and off. This requires that the power switch on the rear side of the instrument is switched on. If the instrument is switched on, the POWER LED is green; if the instrument is switched off but in standby mode, the POWER LED is yellow.

2.3.3.2 Start Screen and Booting of the R&S UPP

- **Without connected monitor**

After switching on the instrument with the standby mode pushbutton, the POWER LED changes from orange to green. After a certain period of time, the BUSY LED lights up, followed by the READY LED. During this boot phase, the Windows operating system boots first followed by the instrument firmware. A self-test is carried out while instrument firmware is booted. The most recent instrument settings saved automatically at power-off are then loaded so that the instrument is in the same state as it was before power-off. If the READY LED is on, the instrument is ready for operation and can be operated via remote control.

- **With connected monitor, ext. keyboard and mouse**

After the instrument is turned on, the BIOS version that is installed and the computer characteristics are displayed on the screen for several seconds.

Afterwards, the Windows operating system boots first followed by the instrument firmware. A self-test is carried out while instrument firmware is booted. The most recent instrument settings saved automatically at power-off are then loaded so that the instrument is in the same state as it was before power-off. After booting is completed, the audio analyzer screen is displayed and the instrument can be operated manually via an external keyboard and a mouse or via remote control.

2.3.3.3 Restarting the R&S UPP

- **Without connected monitor**

Press the standby mode pushbutton. The BUSY LED and the READY LED extinguish at the same time. The POWER LED changes from green to orange after a while. Press the standby mode pushbutton again. After the READY LED is green again, the instrument is ready for operation.

- **With connected monitor, ext. keyboard and mouse**

If the R&S UPP firmware was closed without shutting down the operating system (e.g. by clicking on the  icon in the title bar or ALT F4 on the keyboard), the program can be restarted with the mouse in two ways:

- Clicking on the "R&S UPx firmware" icon on the desktop
- Clicking on the Start button in the taskbar, and then selecting the folders "All Programs, Rohde & Schwarz, UPP" and clicking on the "R&S UPx firmware" icon

- **With remote control**

You can also shut down the operating system by using the "SYSTEM:SHUT-down" command.



In case of an unexpected software lockup, the instrument can be rebooted only by switching the power switch on and off again and pressing the standby mode pushbutton. When using an external monitor, an external keyboard and a mouse, we recommend carrying out a warm start first using the shortcut Ctrl+Alt+Del (restart) or trying the Restart icon with the green arrow.

2.3.3.4 Switching Off

NOTICE

Risk of data loss

There is a risk of data loss if the R&S UPP is shut down without shutting down the operating system first. This may cause trouble during the boot process the next time the instrument is switched on.

We strongly recommend shutting down the operating system **before** switching off the instrument ([SHUTDOWN] button or via mouse operation). Shutting down the operating system ensures that open files are closed properly.

- **Without connected monitor**

Press the standby mode pushbutton. The BUSY LED and the READY LED extinguish at the same time. The POWER LED changes from green to orange. If necessary, the power switch at the rear of the instrument can now be switched off without any problems to completely disconnect the instrument from the AC supply.

- **With connected monitor, ext. keyboard and mouse**

- Click on Start, Shut Down, OK or the red Shutdown icon.
- Shortcut Ctrl+Alt+Del, Shut down, OK

2.4 Function Check

The audio analyzer monitors the most important instrument functions automatically when it is switched on.

2.5 Presets

- **Without connected monitor**

A preset can be executed only via the remote control command (Common Command) *RST.

- **With connected monitor, ext. keyboard and mouse**

Open the menu bar and select "Preset (Load Default)".

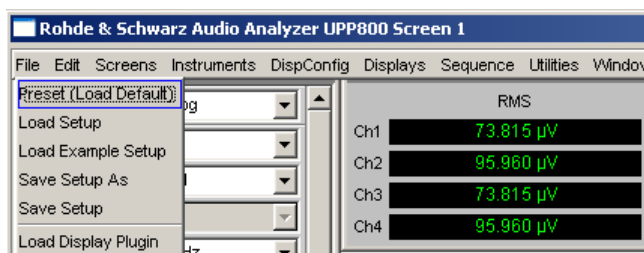

The preset function sets all parameters and settings, even those of inactive operating modes.

The most important parameters set here are:

Generator frequency (analog)	1 kHz
Generator level (analog)	0.1 V
Generator signal	Sinusoidal
Generator frequency (digital)	997 Hz
Generator level (digital)	0.1 FS
Generator signal	Sinusoidal
Generator output impedance	25 Ω
Analyzer interface (analog)	XLR measuring input (analog)
Analyzer interface (digital)	Unbalanced input (BNC socket)
Analyzer function	RMS
Analyzer input impedance	200 kΩ
Frequency measurement	ON

2.6 Windows Operating System

NOTICE

Possible malfunction of the instrument function due to external software

The instrument operates under the Windows operating system. This allows external software programs to be installed on the instrument. The use and installation of commercial off-the-shelf (COTS) software may impair the instrument's functionality.

For this reason, we recommend that you only execute programs tested by Rohde & Schwarz with regard to their compatibility with the instrument software. In certain cases, the use of these programs may also impair the performance of the instrument.

The drivers and programs used in the instrument under Windows have been adapted to the measuring instrument. Existing instrument software must only be modified with update software released by Rohde & Schwarz. Only the settings described below may be performed.

In its delivery state, the configuration of Windows is optimized to the functions of the audio analyzer. Changes in the system setup are only required when peripherals like a keyboard or printer are installed or in the event that the network configuration does not correspond to the default settings (see sections below). After switching on the audio analyzer, the operating system boots and the instrument firmware is started automatically without a password prompt (auto login).



Auto login is performed with the user name and the password "instrument". The user has administrator rights so that printer and network installations are possible.

The operating system can only be accessed if an external keyboard is connected. The Windows key on the external keyboard (next to the [STRG] key) opens the Windows start menu; the Windows programs can then be called from this menu. Connecting a mouse makes Windows easier to use. The system settings under Windows are entered in the menu "Start – Control Panel" (see the description of Windows and the hardware for information on the necessary settings). The R&S UPP does not feature a diskette drive. Data is exchanged using a USB stick

which is inserted into one of the USB interfaces. The USB stick is automatically assigned a free drive letter and the data can be transferred in Windows Explorer.

2.6.1 Retrieving Computer Hardware Information and Windows Operating System

The function of some interfaces depends on which internal computer hardware the R&S UPP has been equipped with. This description makes reference to the computer hardware at some points. With **firmware versions 3.x** and older, the **Windows version** and the **computer hardware information** can be retrieved as follows: Call up the system settings under Windows via the menu "Start – Control Panel – System". This opens a window with the name "System Properties". The desired information can be found under the "General" tab:

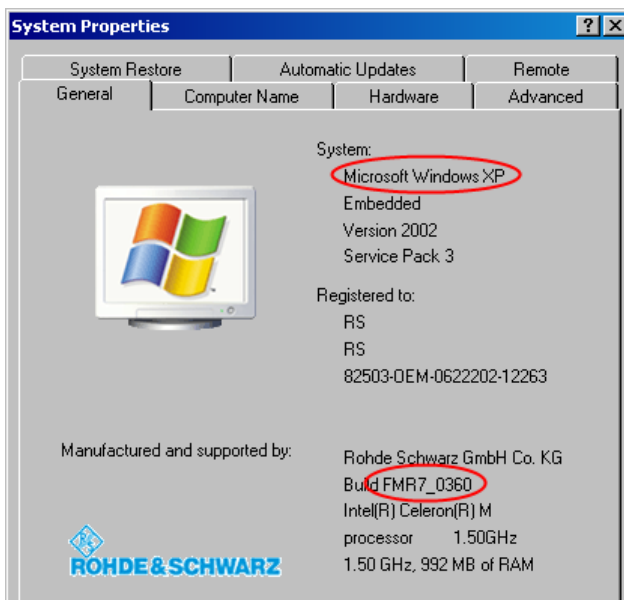

With **firmware version 4.x**, the **computer hardware information** can be checked directly in the firmware via "Help" – "About" under "CPU type:", and the **Windows version** can be checked under "Windows:".

Connecting External Keyboard and Mouse

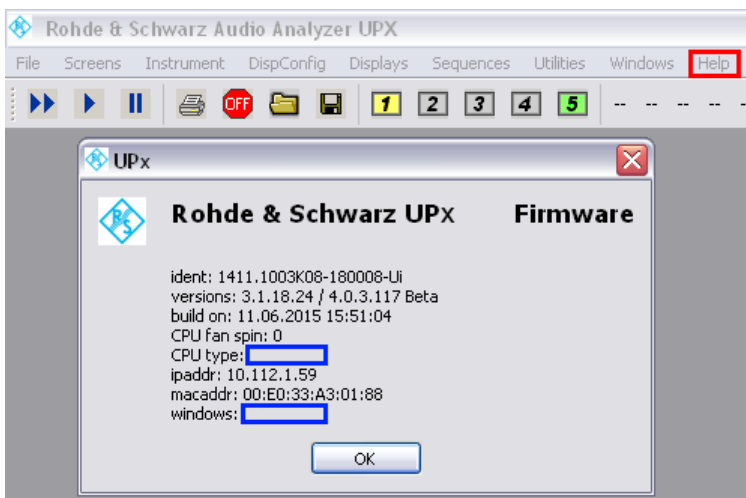

2.7 Connecting External Keyboard and Mouse

2.7.1 Connecting an External Keyboard.

The R&S UPP allows connecting a commercially available, external keyboard with USB interface. A keyboard simplifies the input of list entries, comment texts, file names, etc. and is required for operating Windows.

The keyboard is connected to one of the USB interfaces at the front or rear of the instrument.

The keyboard is detected automatically when it is connected. The US keyboard assignment is the default setting. A change of the keyboard language assignment and special settings, such as the repeat rate etc., can be performed in the Windows menu "Start - Control Panel - Keyboard" or "Regional and Language Options". The menu is opened by pressing the Windows key on the external keyboard.

2.7.2 Connecting an External Mouse

The R&S UPP allows connecting a commercially available mouse with USB interface. The mouse makes it easier to move and resize the panels / graphical windows on the screen and provides alternative operating modes. This is recommended for convenient operation of Windows.

The mouse is connected to one of the USB interfaces on the front or rear of the instrument.

The mouse is detected automatically when it is connected. Special settings, such as the speed of the mouse cursor etc., can be performed in the Windows menu "Start - Control Panel - Mouse". The menu is opened by pressing the Windows key on the external keyboard.

2.8 Connecting an External Monitor

NOTICE

Possible Impairments to Instrument Function

Make sure that the instrument is switched off before connecting the monitor. Otherwise, the monitor or the R&S UPP may be damaged.

Do not modify the screen driver (Display type) and the display configuration since this impairs instrument operation.

The R&S UPP provides the option of connecting an external monitor with DVI-D connection to the DVI-D socket at the rear of the instrument.

Connection

To prevent damage to the monitor and R&S UPP, the instrument must be switched off before an external monitor is connected. After connection, the external monitor is detected when the instrument is started (but not if it is connected while the instrument is in operation). The screen contents with all elements, e.g. panels, measurement displays, softkey bar, etc., appear on the external monitor. No further settings are needed.

2.8.1 Changing Screen Resolution of External Monitor under Windows XP

The R&S UPP audio analyzer is equipped with an internal computer. The setting of the screen resolution when using an external monitor is described below.

Setting external monitor resolution to higher than 800 x 600 pixels

1. Right-click the desktop to open the context menu.
2. Select "Graphics Properties ...".
3. A dialog box opens in which a screen resolution can be selected, e.g. "1024 x 768".
4. Click on "Apply".
5. Click "OK" to confirm the change, and then click "OK" again to close the window.

Resetting the External Monitor to a Resolution of 800 x 600 Pixels

The external monitor, mouse and keyboard are connected to the R&S UPP, the R&S UPP is switched on.

1. Exit or minimize the UPP program by clicking the  buttons on the right in the title bar.
2. Right-click on the desktop to open the following context menu again:

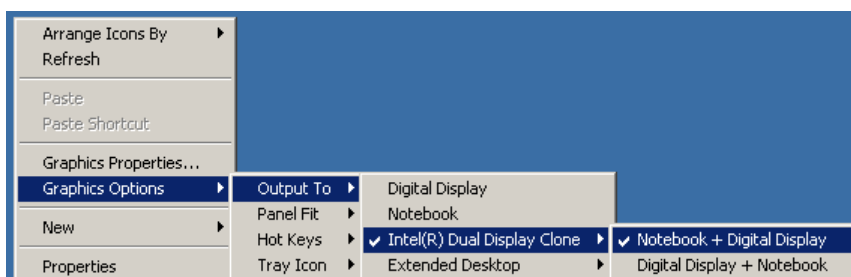

3. "Notebook + Digital Display"
The resolution is reset to 800 x 600.

NOTICE**Switching On the External Monitor**

The external monitor is usually switched on each time the R&S UPP is started to correct any accidental changes to the monitor's starting configuration that may make it impossible to operate the instrument. If this measure does not show the usual user interface, connecting an external keyboard and using the shortcut CTRL + ALT + F4 forces the instrument to connect to the external monitor. The previously configured screen resolution remains intact.

2.8.2 Changing Screen Resolution of External Monitor under Windows 7

The R&S UPP audio analyzer has a built-in computer which, if an external monitor is used, allows the screen resolution to be set.

Changing resolution of external screen

1. Switch off R&S UPP.
2. Connect the external monitor, keyboard and mouse.
3. Switch on R&S UPP.
4. After starting the R&S UPP, exit or minimize the UPP program by clicking on the  buttons on the right in the title bar.
5. Right-click the desktop to open the context menu.
6. Select "Screen resolution" and set the desired resolution in the "Resolution:" field. Click "Apply" and then "OK" to apply the new screen resolution. If the resolution 800x600 is grayed out and therefore cannot be changed, proceed to point 7.
7. Close the "Screen resolution" window. Open the context menu again and select "Graphics Properties".... In the Display Devices tab, set "Single Display" under Operating Mode and then set "Digital Display" under Display Selection. In the Display Settings tab, set the desired resolution. Click "Apply" and then "OK" to apply the new screen resolution.

2.9 Installing Options

The R&S UPP can be equipped with a few options. These options can be divided into two basic categories:

Software options	These can be installed by the user alone; installation instructions and a unique activation code supplied with the option are required.
Hardware options	These are installed in the R&S UPP audio analyzer, can be retrofitted only by a Rohde & Schwarz service facility.

2.10 Connect R&S UPP to a Network (LAN)

The R&S UPP has a network connector and can be connected to a LAN (Local Area Network).

Network administrators with the appropriate rights can transfer files across the network and use network resources such as the network directories or printers. The instrument can also be remote-controlled and manually operated in the network.

The manual remote allows operating the R&S UPP from any remote external computer. For example, the user can operate one or several R&S UPPs from his workplace that are integrated in a test setup in another part of the building.

The R&S UPP is shipped with activated Windows firewall. File transfer via LAN or manual remote operation using the remote desktop requires only a partial exception in the firewall. It is advisable to coordinate the configuration of the firewall with the network administrator.

The remote control of the instrument via the LAN interface is described in the operating manual on the documentation CD.

2.10.1 Connection to the Network

NOTICE

Possible malfunction of the network operation

It is recommended that the connection of the instrument to the network be coordinated with the network administrator. Connection errors may affect the entire network.

Do not connect or disconnect the network cable until the instrument is switched off (standby). Only then can the network connection be reliably detected and impairments to instrument operation can be avoided.

The instrument is connected to the network using a commercially available RJ-45 cable connected to the LAN interface at the rear of the instrument. In order to suppress electromagnetic interference, it is recommended to use suitable shielded CAT6 or CAT7 cables of high quality.



2.10.2 Configuration of R&S UPP for Network Operation

The network interface operates with 100-MHz Ethernet IEEE 802.3u. The TCP/IP network protocol and the associated network services are preconfigured.

In order to exchange data in a local network (LAN), each connected computer or instrument must have a unique IP address or a unique computer name. In addition, network access of the different users is organized by the assignment of access rights.

The access rights determine which of the available network resources, e.g. file storage systems, are available for the R&S UPP.

Networks with DHCP

The R&S UPP is preconfigured for networks using DHCP (dynamic host configuration protocol). In these networks, the R&S UPP is automatically assigned an unused IP address.

In this case, a unique computer name is used for identification in the network. Every R&S UPP is assigned an individual computer name at the factory. This name can be queried in the Windows menu "Start - My Computer" and changed (see [Chapter 2.10.2.3, "Querying the computer name"](#), on page 44).

Networks with fixed IP addresses

In networks using fixed IP addresses, the addresses are mostly assigned by the network administrator. The fixed IP address must be entered in the Windows menu "Start - Control Panel" (see [Chapter 2.10.2.2, "Entering the IP Address"](#), on page 41).

Point-to-point connections

To set up a simple network – a LAN connection between an R&S UPP and a computer without integration in a larger network – an IP address must be assigned for the R&S UPP and the computer. The IP addresses 192.168.xxx.yyy are available, whereby both xxx and yyy can have the values 1 to 254; the value for the subnet mask is 255.255.255.0.

In this case, a commercially available crossover RJ-45 cable must be used for the connection. In order to suppress electromagnetic interference, it is recommended to use suitable shielded cables of high quality.

User ID

For the R&S UPP, the user **instrument** has been defined. The user is used for the auto login when the instrument is started and for manual remote operation. The password is also **instrument**. By assigning the respective rights, the network administrator decides which directories and resources in the network can be accessed by the R&S UPP.

2.10.2.1 Preparations

The instrument is configured for network operation in the menus of the Windows operating system. The operating system can only be accessed if an external monitor and an external keyboard are connected; connection of a mouse is recommended for easy operation. The instrument should be switched off before the monitor, keyboard and mouse are connected. This will ensure that they are correctly detected by the operating system.

2.10.2.2 Entering the IP Address

By default, "Obtain an IP address automatically " (DHCP (Dynamic Host Configuration Protocol) is preset.

When using Windows XP:

1. "Click on Start – Settings – Control Panel".

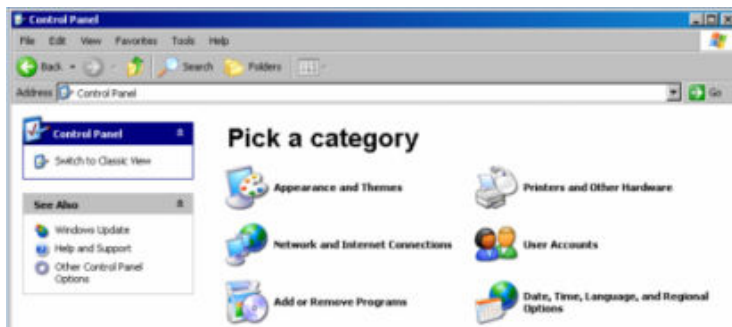

2. "Click on Network and Internet Connections" and then click on "Network Connections" at the bottom right in this menu.

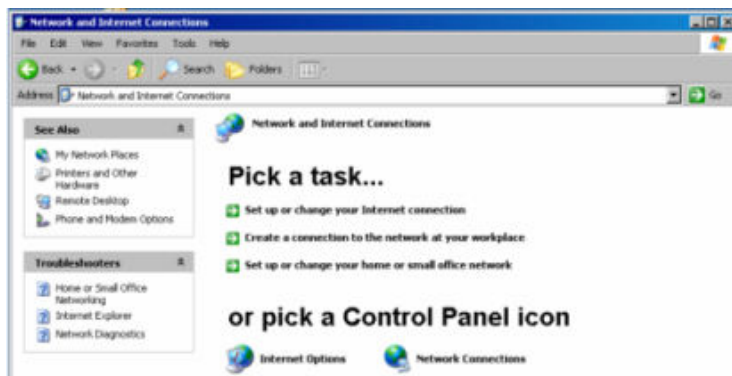

3. Right-click in the menu "Network Connections Local Area Connection" and then click on "Properties".

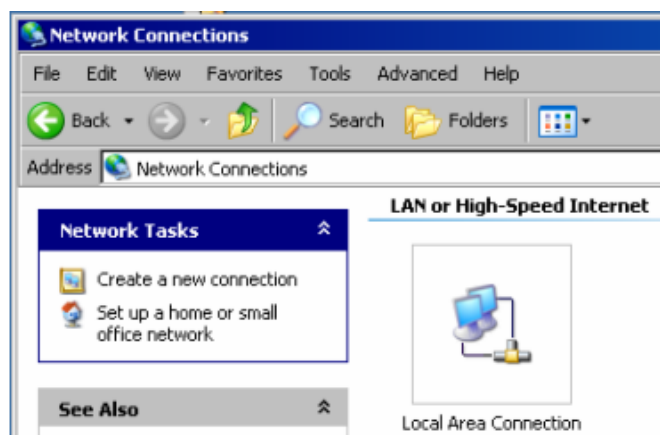

Connect R&S UPP to a Network (LAN)

4. On the "General" tab in the field "This connection uses the following items:", mark the "Internet Protocol (TCP/IP)" selection and then click on "Properties".

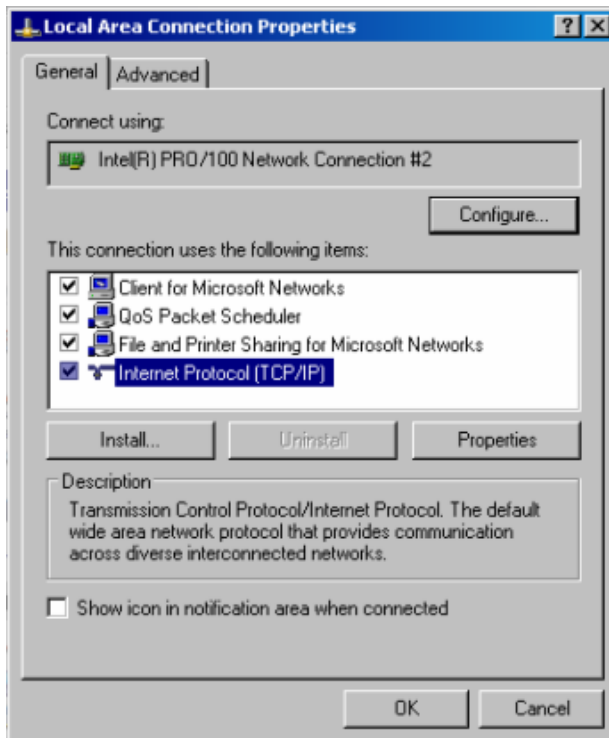

5. In the "Internet Protocol (TCP/IP) Properties" menu, enter the IP address in the "Use the following IP address" field (the complete data are available from the network administrator). Complete the entry with "OK" in all menus.

Connect R&S UPP to a Network (LAN)

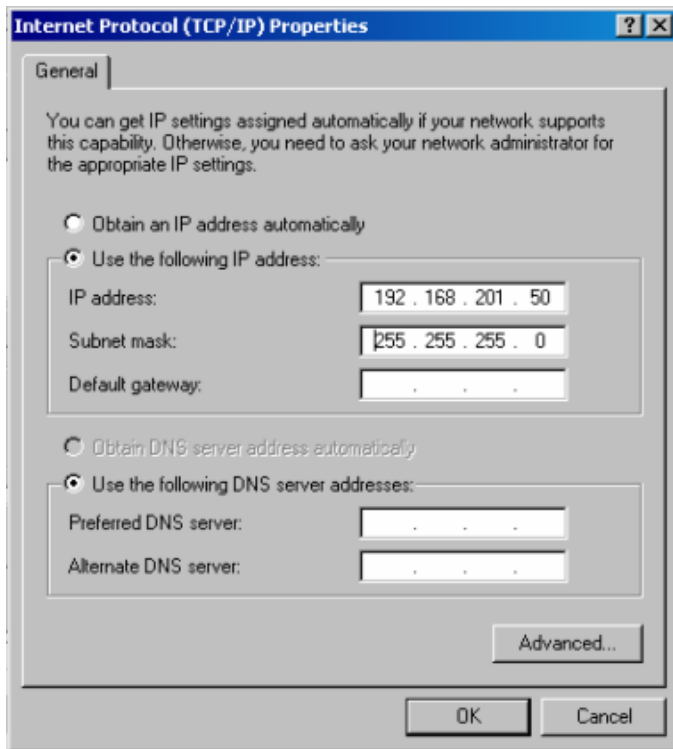

When using Windows 7:

1. Open the Control Panel, then select "Network and Sharing Center".

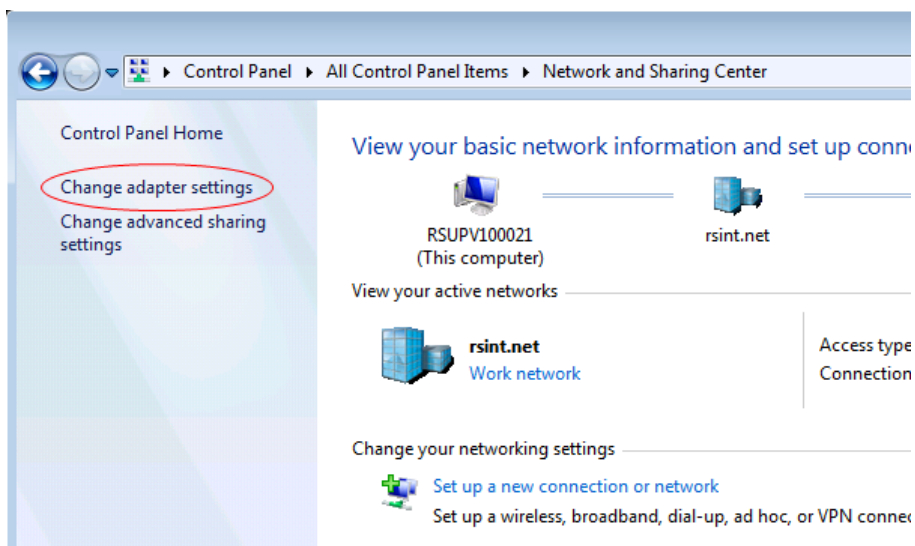

2. Click on "Change adapter settings" and then right-click on "Local Area Connection"

Connect R&S UPP to a Network (LAN)

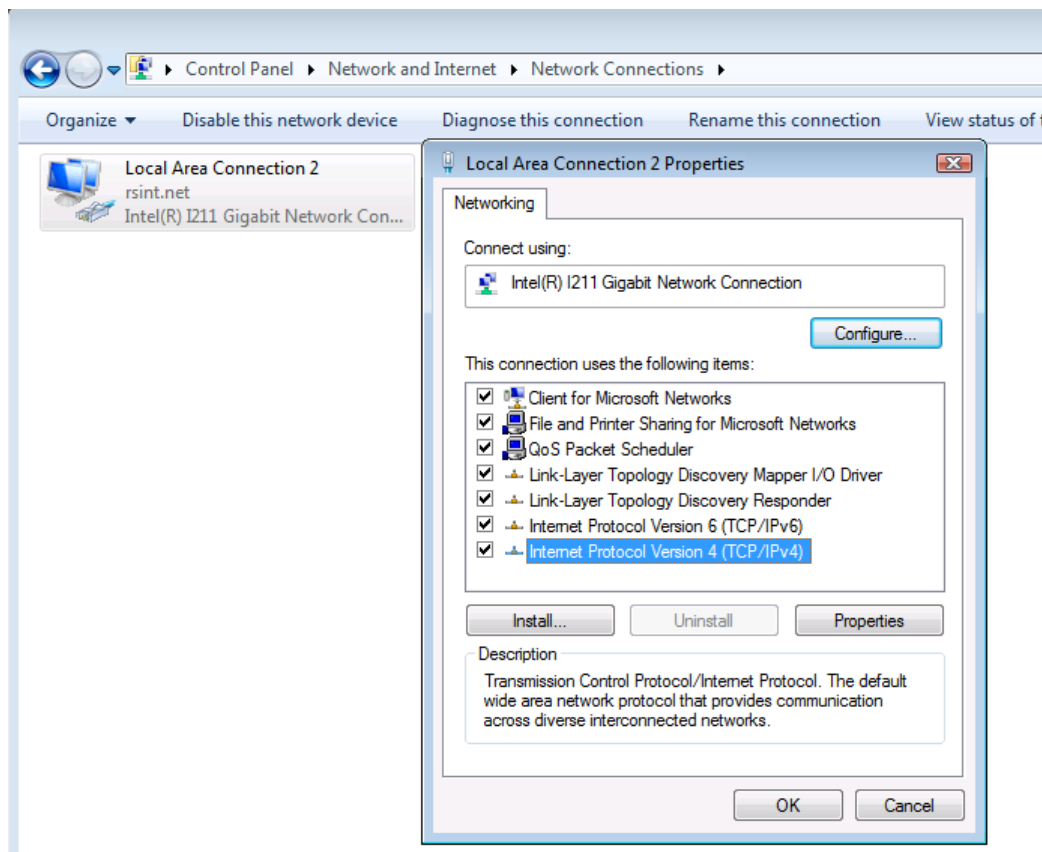

The "Networking" tabs opens.

3. Select "Internet Protocol Version 4 (TCP/IPv4)" and then click on "Properties".
4. Select "Use the following IP address:" and enter the IP address.

2.10.2.3 Querying the computer name

When using Windows XP:

1. "Click on Start – Control Panel: Performance and Maintenance"
2. "Click on System" and select "Computer Name" in the tab menu.

The computer name is displayed under "Full Computer Name". It can be changed in the "Change" submenu.

Connect R&S UPP to a Network (LAN)

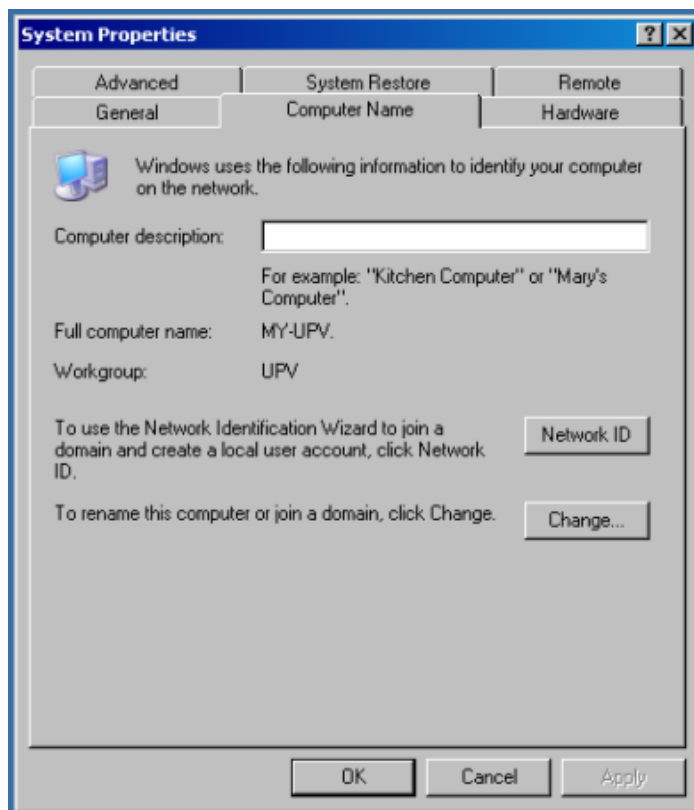

When using Windows 7:

- ▶ "Click on Start – Control Panel - System"

The computer name is displayed and can be changed.

2.10.2.4 Accessing directories in the network

Access to network drives depends on access rights and whether the drives in question have been enabled. The complete integration of R&S UPP in a larger network with the required rights assignment is very complex and is generally performed by a network administrator.

Access from R&S UPP to the hard disk of a computer that is also connected to the network can, however, be performed relatively easy. The directory which the R&S UPP is to access simply has to be enabled on the remote computer. Access from R&S UPP to this directory is done with the help of a Windows search function.

This procedure is also of importance for a point-to-point connection, for instance in order to start a firmware update for which the files have been stored on the hard disk of the remote computer.



Both the computer and the audio analyzer must have a computer name and an IP address (see [Chapter 2.10.2, "Configuration of R&S UPP for Network Operation"](#), on page 39).

The menu name may deviate from the name specified in the following operating sequence, depending on the language and on the operating system used on the computer.

Enabling the desired directory on the remote computer

1. On the computer, select the directory to be enabled in Windows Explorer and right-click to call up the "Properties" menu.
2. In the "Sharing" panel, activate the "Share this folder" check box.
3. Record the computer name of the PC (see [Chapter 2.10.2.3, "Querying the computer name"](#), on page 44).

At the R&S UPP, access the enabled directory

1. Use the Windows key to call up the "Start" menu.
2. In the menu, select "Search Computers or People", followed by "A Computer on the Network".
3. In the input window with the query "Which computer are you looking for?", enter the name of the computer and start the search with Enter.
The PC is listed with its computer name as the search result.
4. Click on the computer name. The enabled directory is displayed and the files stored in it can be used in the R&S UPP.

Note: If a user name and password are requested when you click the computer, the login name and password used on the computer must be entered.

2.10.3 Configuration via LXI

LAN eXtensions for Instrumentation (LXI) is an instrumentation platform for measuring instruments and test systems that is based on standard Ethernet technology. LXI is intended to be the LAN-based successor to GPIB, combining the advantages of Ethernet with the simplicity and familiarity of GPIB. This standard provides a new way for configuring virtual front panel instruments by using a network and a Web interface. The main tool for this configuration method is a

browser, such as Microsoft Internet Explorer, but it is also possible to use other browsers such as Firefox or Netscape.

2.10.3.1 LXI classes and LXI functionality

LXI-compliant instruments are divided into three classes, A, B and C, with the functionality of the classes hierarchically based one upon the other:

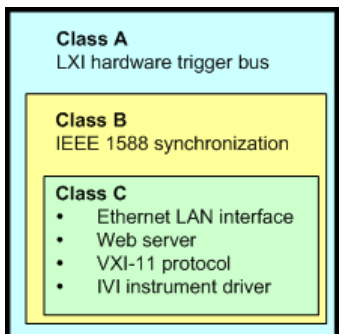

- Class C instruments are characterized by a common LAN implementation, including an ICMP ping responder for diagnostics. The instruments can be configured via a web browser; a LAN Configuration Initialize (LCI) mechanism resets the LAN configuration. LXI instruments of class C must also support automatic detection in a LAN via the VXI-11 discovery protocol and programming by means of IVI drivers.
- Class B adds IEEE 1588 Precision Time Protocol (PTP) and peer-to-peer communication to the base class C. IEEE 1588 allows all instruments on the same network to automatically synchronize to the most accurate clock available and then provide time stamps or time-based synchronization signals to all instruments with exceptional accuracy.
- Class A-instruments are additionally equipped with the eight-channel hardware trigger bus (LVDS interface) defined in the LXI standard.

Instruments of classes A and B can generate and receive software triggers via LAN messages and communicate with each other without involving the controller.

The R&S UPP meets the general requirements of LXI Class C. In addition to the properties described above, the instrument offers the following LXI-related functions:

- Integrated display of the current instrument settings
- Possibility of remote controlling the instrument within the WEB browser.

2.10.3.2 LXI LAN Indicator

The green LAN LED on the front panel of the R&S UPP shows the LAN status of the instrument. The LAN LED indicator has three states.



- LAN LED off
 - The instrument does not have valid IP address. This may be due to one of the following reasons:
 - 1) the instrument is configured with DHCP, but no DHCP router is connected,
 - 2) the instrument is manually configured and an IP address conflict is present,
 - 3) the instrument lost its IP address that was configured with DHCP and switched to Auto IP.
 This state is called "error state" and normally can be resolved by the LCI mechanism (LAN reset). This mechanism is required by the LXI standard and can be invoked with the "LAN RESET" button (key press > 10 s) on the front side of the instrument (see [Chapter 2.2, "Description of the Rear Panel"](#), on page 19).
- LAN LED is on
 - The instrument has a valid IP address and is reachable via TCP/IP.
- LAN LED flashes
 - The instrument is in the "Device Indicator" state initiated by the WEB interface. This state is required by the standard and is used for finding instruments in racks (see [Chapter 2.10.3.4, "LXI Browser Interface"](#), on page 49).

2.10.3.3 LXI Default State of Network Settings

After a LCI (LAN reset), the instrument automatically reboots and starts up with following LAN settings:

Connect R&S UPP to a Network (LAN)

Parameter	Setting
Hostname	RSUPPvvv-xxxxxx
Description	Audio Analyzer
TCP/IP Mode	DHCP + Auto IP Address
Dynamic DNS	Enabled
ICMP Ping	Enabled
Negotiation	Auto Detect
VXI-11 Discovery	Enabled
Password for LAN Configuration	LxiWebIfc



More information about the LXI standard is located on the LXI website under

<http://www.lxistandard.org>

or in the article about LXI in

"News from Rohde & Schwarz, 2006/II - 190".

2.10.3.4 LXI Browser Interface

The only information necessary for performing configuration via the LXI/Web interface is the name of the instrument (which means its Windows name) in networks that operate with DHCP enabled, or its IP address in networks that operate with manual network configuration. In rare cases where neither one of these names is known, it is also possible to derive the IP address from the MAC address, which is printed on the rear panel of the instrument.

The instrument's LXI browser interface works correctly with all W3C compliant browsers.

To start the instrument home page (welcome page), open a browser on the PC and enter the instrument name or the IP address of R&S UPP in the address field, e.g.

`http://RSUPP800-180108` or `http://10.215.1.100`.

The instrument name for the R&S UPP is always RSUPPvvv-xxxxxx, whereby vvv represents the variant (200, 400 or 800 according to variants 02, 04 or 08), and xxxxxx represents the six-digit serial number of the instrument.

Connect R&S UPP to a Network (LAN)

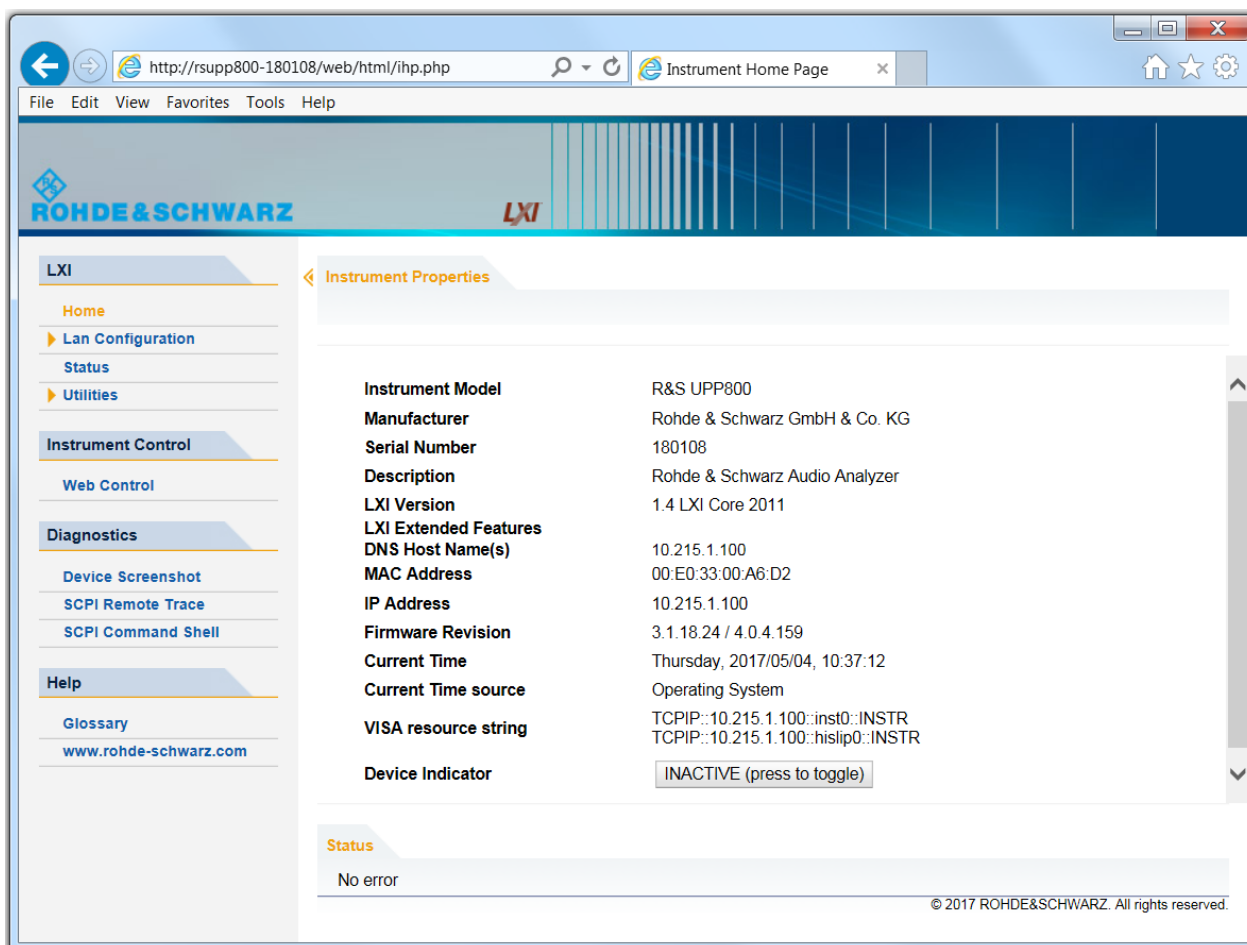

The instrument home page shows all important information in a compact form. The MAC address and the (often dynamically assigned) IP address as well as the complete resource string for the remote control via VISA are also located here.

The LAN indicator on the instrument will blink if Device Indicator is set to ACTIVE. Clicking on "INACTIVE (press to toggle)" switches the status on and off. It can be used to quickly identify an instrument that is mounted together with several other instruments of the same type, such as in a 19" rack.

Device Indicator

Clicking on "ACTIVE (press to toggle)" switches the flashing state off again.

Device Indicator ●

The left side shows a navigation bar containing the important "LAN Configuration" menu. This page of the LXI Web configuration website enables extensive configuration of all important LAN parameters, which is necessary because the configu-

Connect R&S UPP to a Network (LAN)

ration steps mentioned in the next sections cannot be performed as described with a virtual front panel instrument.



Changing the LAN configuration is password-protected. The password reads LxiWebIfc (notice upper and lower case characters). This password cannot be changed in the current firmware version.

2.10.3.5 IP Configuration

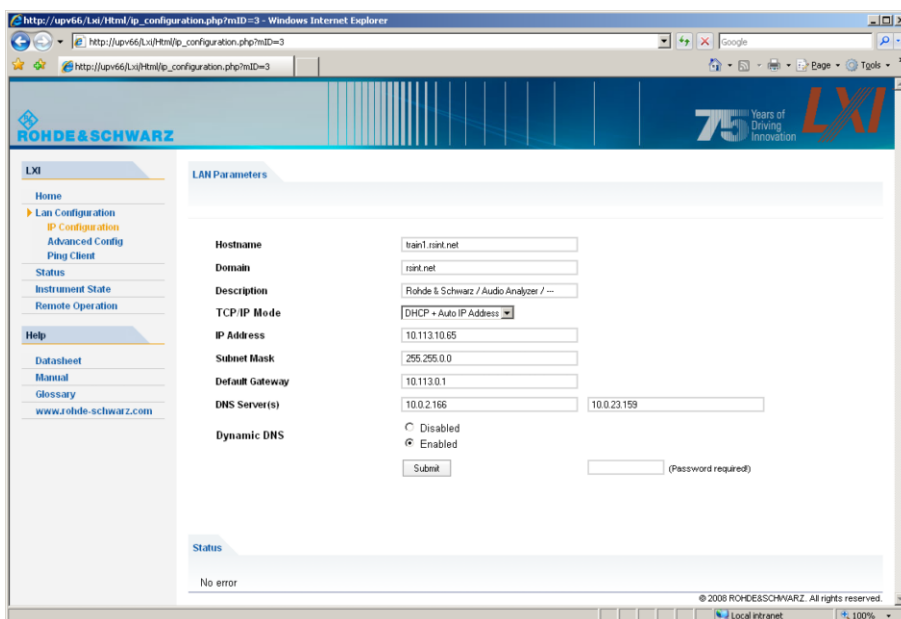

- TCP/IP Mode
 - decides whether DHCP is switched on or not. The IP Address, Subnet Mask, Default Gateway and DNS Server configuration fields are only enabled if DHCP is disabled. Consult the network administrator if it is necessary to modify these settings or any other settings.



Switching from DHCP enabled mode to manual configuration mode may trigger an instrument restart when the new setting is confirmed (depends on the configuration). If incorrect network configuration settings have been entered, LAN RESET on the rear panel of the instrument must be used to restore access to the Web interface.

- IP address
 - Allows the IP address of the instrument to be modified if DHCP is disabled.

Connect R&S UPP to a Network (LAN)

- Subnet mask, default gateway
 - are settings that may have to be changed at times compared to the displayed presets if DHCP is switched off. Consult the network administrator for the proper values if it is necessary to modify these settings.
- DNS server
 - This is the IP address of the domain name server of the network segment. Consult the network administrator if it is necessary to modify this setting when operating with DHCP disabled.
- Dynamic DNS
 - Allows different DNS servers to be addressed in succession. Consult the network administrator if it is necessary to modify this setting when operating with DHCP disabled.

2.10.3.6 Advanced LAN Configuration

"Advanced LAN Configuration" provides LAN settings that are not declared mandatory by the LXI standard. These advanced parameters should only be modified by experienced users.

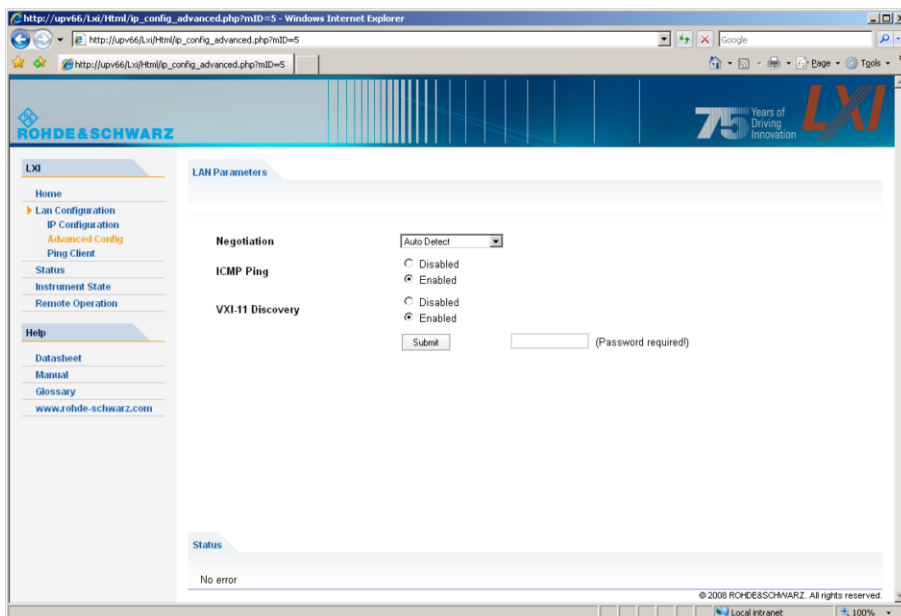

- Negotiation
 - The Negotiation configuration field provides different Ethernet speed and duplex mode settings. In general, the Auto Detect mode is sufficient.
- ICMP Ping

Connect R&S UPP to a Network (LAN)

- ICMP Ping must be enabled to use the ping utility.
 - VXI-11 Discovery
 - Enables or prevents discovering the instrument via the VXI-11 Discovery protocol, which is a protocol jointly developed by National Instruments and VISA for searching for devices on a LAN.
- VXI-11 is the protocol that is used for discovery of the instrument in the LAN. According to the standard, LXI instruments must use VXI-11 to provide a discovery mechanism; other additional search methods are permitted.

2.10.3.7 Ping Client

Ping is a utility that verifies the connection between the LXI-compliant instrument and another instrument. The ping command uses the ICMP echo request and echo reply packets to determine whether the LAN connection is functional. Ping is useful for diagnosing IP network or router failures.

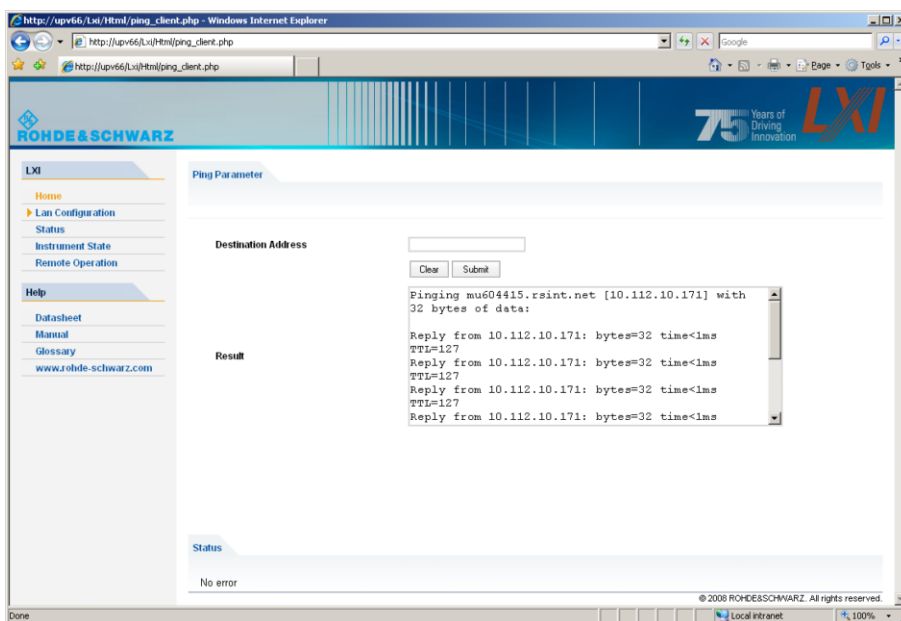

The ping utility is not password-protected.

To initiate a ping between the LXI-compliant instrument and a second connected instrument:

1. "Activate ICMP Ping" on the "Advanced LAN Configuration" page (activated after LCI).

Connect R&S UPP to a Network (LAN)

2. Enter the IP address of the second device without the ping command and without any further parameters into the Destination Address field (e.g. 10.113.10.203).
3. Click on "Submit".

2.10.4 Configuration for manual remote operation

The R&S UPP can be operated manually from an external computer via a network connection. The Windows program Remote Desktop Connection is used for operation, see [Chapter 4.16, "Manual Remote Operation"](#), on page 197.

Manual remote control of the audio analyzer is possible under the following conditions:

- the Windows 95 operating system or higher and the Remote Desktop Connection program are installed on the external computer and a LAN interface is configured for the network
- the audio analyzer and the computer are connected via LAN (see [Chapter 2.10.2, "Configuration of R&S UPP for Network Operation"](#), on page 39),
- the Remote Desktop Connection program is activated on the audio analyzer (see [Chapter 2.10.4.1, "Activating the Remote Desktop Connection program at the R&S UPP"](#), on page 55),
- on the external computer, the R&S UPP data have been entered in the Remote Desktop Connection program (IP address or computer name of R&S UPP in the network (see [Chapter 2.10.2.3, "Querying the computer name"](#), on page 44),
- the login at the external computer for R&S UPP was performed with the correct user name (instrument) and the correct password (instrument) (see [Chapter 2.10.4.2, "Starting manual remote operation at the external computer"](#), on page 56).

2.10.4.1 Activating the Remote Desktop Connection program at the R&S UPP

NOTICE

Unauthorized access possible to audio analyzer

After activating Remote Desktop, access to this R&S UPP is possible for any user in the network who knows the computer name and the login data of the audio analyzer.

When using Windows 7 Remote Desktop Connection is enabled by default.

Activating Remote Desktop when using Windows XP:

1. "Start – Settings – Control Panel": Click on "Performance and Maintenance".
2. "Click on System" and select "Remote" in the tab menu.
3. Activate the "Allow users to connect remotely to this computer" check box.

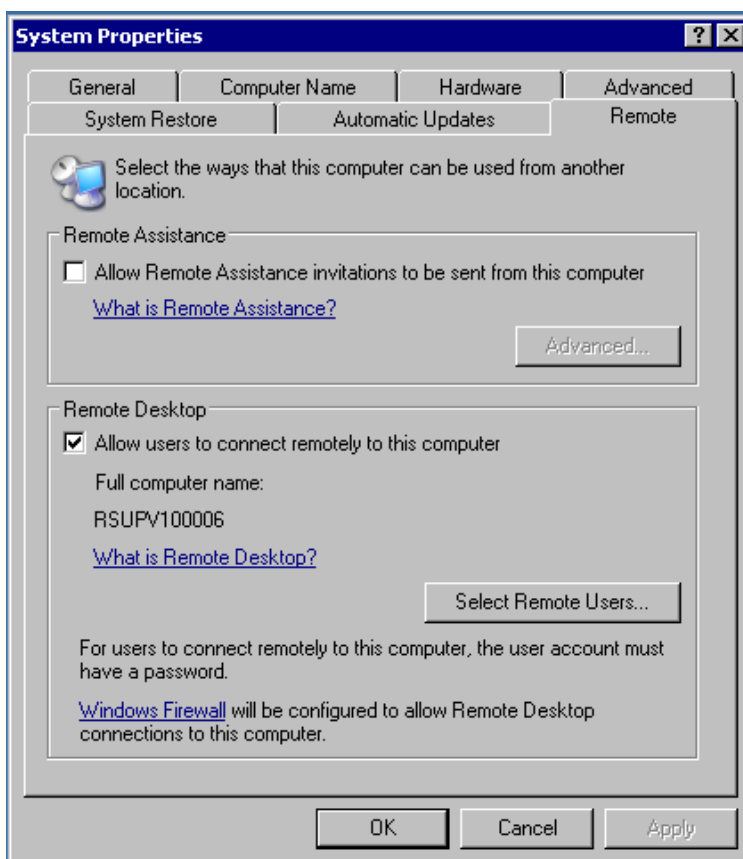

2.10.4.2 Starting manual remote operation at the external computer

The Remote Desktop Connection program is already installed in the Windows operating system (program name "mstsc.exe" in "C:\Windows\System32"). For all other Windows operating systems from Windows 95 and higher, the program can be downloaded free-of-charge from the Internet (<http://www.microsoft.com>). It can be loaded onto any external computer by following the instructions, which are also provided on the Internet.

1. If necessary, install the **Remote Desktop Connection** program on the external computer
2. Start the program in the Windows menu "Start - All Programs - Accessories - Communications".

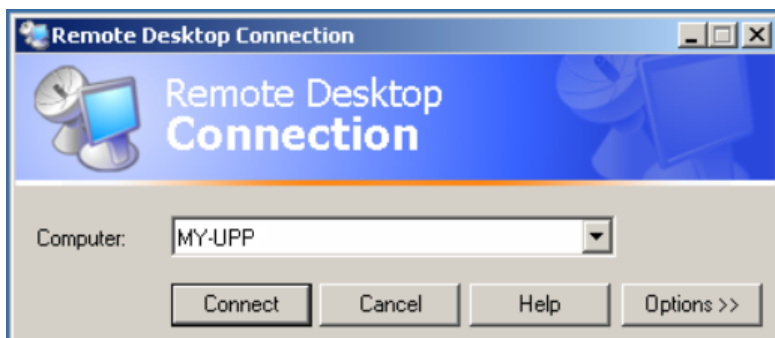

Before the program can be used for the first time, the instrument and user ID of the R&S UPP must be entered on the external computer. The instrument ID - the computer name of R&S UPP - identify the R&S UPP in the network. Every R&S UPP is supplied together with a computer name which can be used for manual remote operation. Querying the computer name is described in [Chapter 2.10.2.3, "Querying the computer name"](#), on page 44.

The user ID is necessary as it authorizes access to the R&S UPP. They are preset on the R&S UPP and are "instrument" for both the user name and the password. No entry is needed in the Domain field.

3. Enter the instrument and user ID on the "General" tab of the extended "Remote Desktop Connection" menu (called up by pressing the "Options>>" button).

Connect R&S UPP to a Network (LAN)

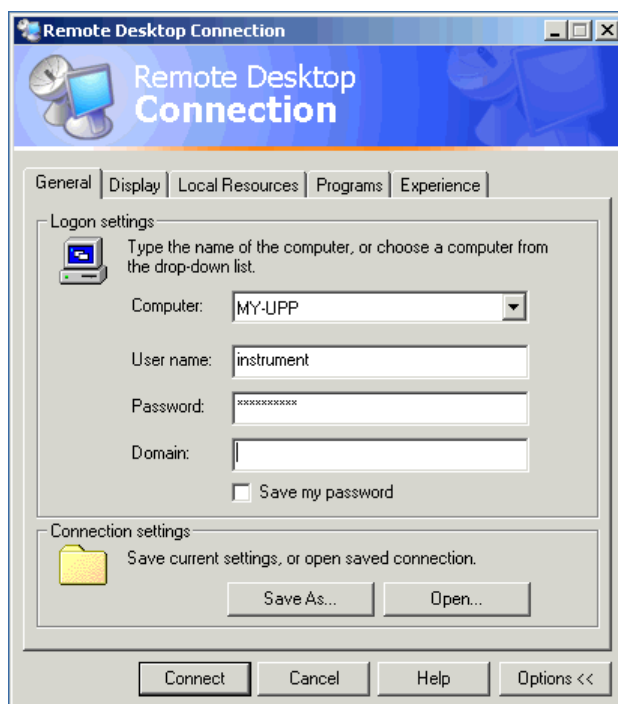

4. The login data can be saved with the "Save as" button. When saving as `default.rdp` file, the connection to R&S UPP is offered as default at the start of the program. When saving under a different name, the setting for the connection with R&S UPP is provided in the selection list which is called up by clicking on the ▾ button in the "Computer:" entry line.
5. The resolution for the display of the R&S UPP monitor is set to 800 x 600 on the Display tab.

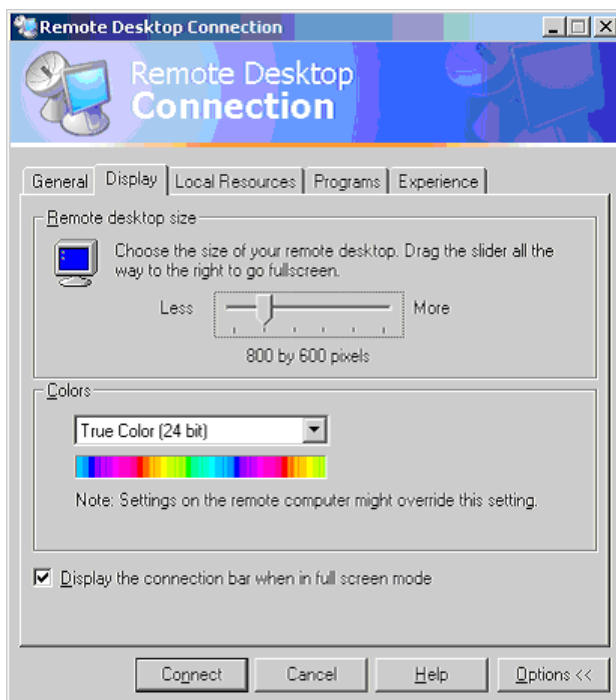

- Establish the connection by clicking on the "Connect" button.
After the connection has been established, the audio analyzer screen appears on the external computer. Operation is possible with the mouse and/or the keyboard.
If several R&S UPPs should be manually remote-controlled by one computer, a separate Remote Desktop Control window must be opened for every R&S UPP. This is possible by repeatedly starting the program on the external computer.

2.11 Firmware Update



The firmware update is described in the Release Notes.

2.11.1 Troubleshooting during a Firmware Update

The two most common problems that can occur when installing the software (or during a major update) are these:

Windows XP Recovery and Backup

- At the beginning, just before the progress bar starts, the progress window displays the text "InstallShield is preparing InstallScript". Occasionally you then see an error message and installation is canceled.
This problem can usually be solved by restarting Windows and carrying out the firmware installation again.
- After the installer has installed the firmware, i.e., the progress bar is completely filled, the progress window displays the text "Removing Backup Files", "Registering Components" or "Publishing Product Information". Here, too, it occasionally happens that an error message is followed by a second message, and the firmware is subsequently not installed.
This problem can sometimes be solved by restarting Windows and carrying out the setup again. If the error occurs again, this can be for two reasons:
 - Installation of the front panel driver went wrong. In this case, it must be installed using the Windows wizard; the required INI file is named `C:\UPV\fpnl_wdm.inf`. You should now reinstall the firmware.
 - The installation of additional Windows settings went wrong. In this case, execute the files `C:\UPP\ScanFirmwareVersions.exe` and `C:\UPP\SetReg.exe` in succession. You should now reinstall the firmware.

If neither of these steps is successful, the instrument needs to go in for service (or the Windows image program must be reloaded).

2.12 Windows XP Recovery and Backup

The R&S UPP provides an invisible backup and recovery partition. A backup of the factory system partition (`C:\`) is saved by default and can be restored in case of a system crash.

In addition, backups of up to 5 firmware versions can be stored on this partition. It is e.g. possible to backup the current system partition prior to a firmware update or to provide different system configurations for different environments.

For the R&S UPP, the connection of an external keyboard is required.

The operation is described with respect to an external keyboard. It is recommended to connect a mouse that allows an intuitive operation!

During restore, the system partition (`C:\`) is deleted, formatted and rewritten. The data partition (`D:\`) is not affected by this.

2.12.1 Calling the Windows XP Recovery and Backup Partition Menu



If several backups are already stored on the disk, the remaining space might not be sufficient for an additional backup. In this case a warning is indicated in the Windows XP Recovery and Backup Partition menu and the user is requested to remove an old backup before making a new one.

1. Switch the instrument off and on again **Press the cursor keys multiple times during the boot phase to ensure that the Boot menu does not independently close after a short period of time.**
2. In the Boot menu, use the cursor keys to select the "Backup/Recovery" line.
3. Open the "Windows XP Recovery and Backup Partition" menu with [ENTER]. The menu shows the available selections for the recovery and backup partition:

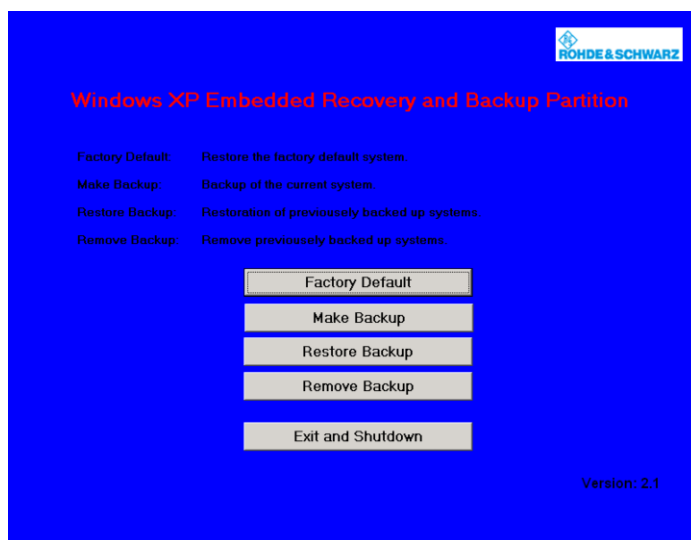

2.12.2 Backup Current System Partition

1. In the Windows XP Recovery and Backup Partition menu, use the cursor keys to select the "Make Backup" button.
2. Open the "Make Backup" menu with the [ENTER] key.

Windows XP Recovery and Backup

The menu shows the current versions of the firmware and the software platform.

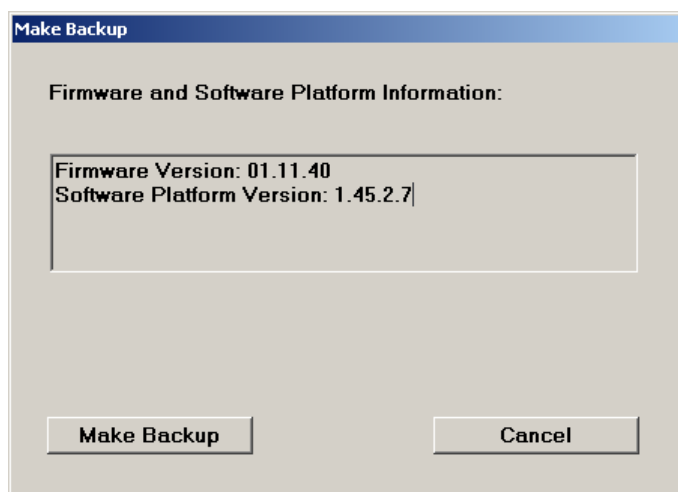

3. Select the "Make Backup" button with the TAB keys.
4. Start the backup by pressing the [ENTER] key.
After the backup, the "Windows XP Recovery and Backup Partition" menu appears again.
5. Select "Exit and Shutdown" with the cursor keys.
6. Exit the program and shut down the R&S UPP with the [ENTER] key.

2.12.3 Restoring a Selected Version of the System Partition

1. Use the cursor keys to select "Restore Backup" in the "Windows XP Recovery and Backup Partition" menu to select the desired version of the system partition.
2. Open the "Restore Backup" menu with the [ENTER] key.
The menu shows the versions of the firmware and the software platform of the backup which is displayed in the "Select Backup" window.

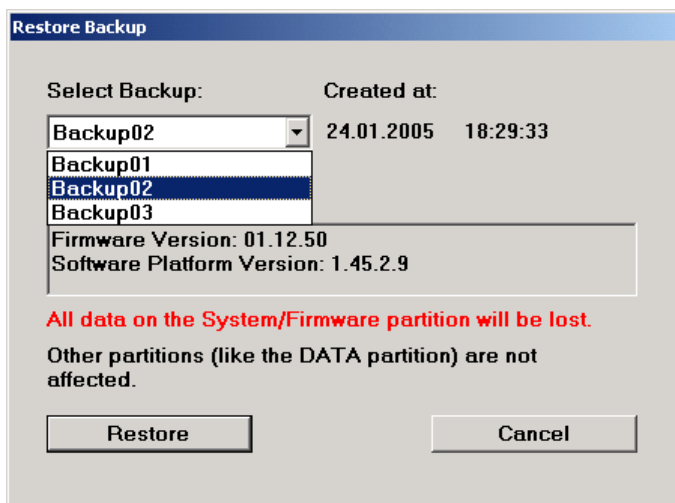

3. Select the "Select Backup" window with the TAB keys.
4. Select the backup to be restored with the up/down cursor keys and the [ENTER] key.
5. Select the "Restore" button with the TAB keys.
6. Start the restore process with the [ENTER] key.
The script that is performed during recovery is displayed.
7. After the restore, shut down and switch off the R&S UPP.
The new setting is now active.

2.12.4 Recover Factory Default

1. Select the "Factory Default" button in the Windows XP Recovery and Backup Partition menu with the cursor keys to recover the factory default version of the system partition.
2. Open the "Factory Default" menu with the [ENTER] key.
The menu shows the versions of the firmware and the software platform on delivery.



3. Select the "Restore now" button with the TAB keys.
4. Start the restore process with the [ENTER] key.
The script that is performed during recovery is displayed.
5. After the restore, shut down and switch off the R&S UPP.
The new setting is now active.

2.12.5 Deleting Backups

Up to five backups in addition to the factory default can be stored on the recovery partition. To provide space for new backups, it might be necessary to remove older backups. The factory default cannot be deleted.

1. Use the cursor keys to select the "Remove Backup" button in the Windows XP Recovery and Backup Partition menu to delete a selected backup.
2. Open the "Remove Backup" menu with the [ENTER] key.
The menu shows the versions of the firmware and the software platform of the backup displayed in the Select Backup window.

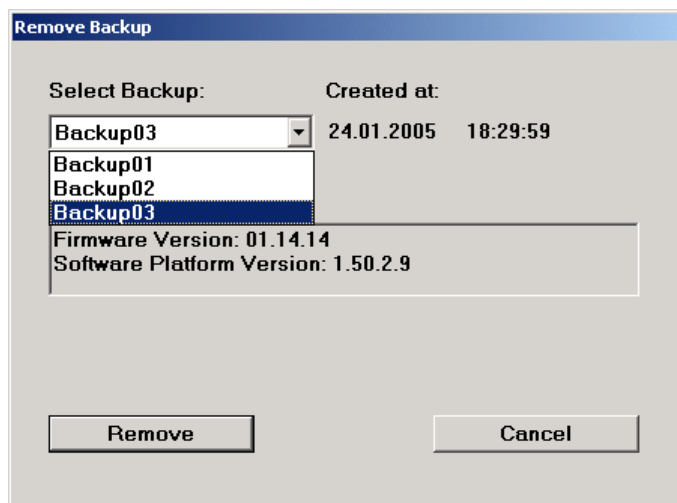

3. Select the "Select Backup" button with the TAB keys.
4. Use the cursor keys and the [ENTER] key to select the backup to be removed.
5. Select the "Remove" button with the TAB keys.
6. Start the removal process with the [ENTER] key.
After the deletion, the instrument returns to the Remove Backup menu as long as backups are still available. If the last backup is deleted, the Windows XP Recovery and Backup Partition menu opens again.
7. Select the "Cancel" button with the TAB keys.
8. Close the "Remove Backup" menu with the [ENTER] key.
The Windows XP Recovery and Backup Partition menu opens.
9. Select "Exit and Shutdown" with the cursor keys.
10. Exit the menu and shut down the R&S UPP by clicking on the [ENTER] key.

2.13 Windows 7 Recovery and Backup

The R&S UPP provides an invisible backup and recovery partition. A backup of the factory system partition (C:\) is saved by default and can be restored in the event of a system crash.

In addition, backups of multiple firmware versions can be saved on this partition. For example, it is possible to backup the current system partition prior to a firm-

ware update or to provide different system configurations for different environments.

For the R&S UPP, the connection of an external keyboard is required.

Operation is described with respect to an external keyboard.

During restore, the system partition (C:\) is deleted, formatted and rewritten. This does not apply to the data partition (D:\).

2.13.1 Calling Windows 7 Recovery and Backup Partition Menu



If several backups are already stored on the hard disk, the remaining memory capacity might not be sufficient for an additional backup. In this case a warning is indicated in the Windows 7 Recovery and Backup Partition menu and the user is requested to remove an old backup before making a new one.

Although the backup/recovery system under Windows 7 looks slightly different to that under Windows XP, it can still be operated in the usual way using an external keyboard.

The figures below show the backup/recovery system for the R&S UPV. They are equally valid for the R&S UPP.

The following window is displayed after every boot procedure. The user can choose between "Firmware" and "Backup", as was the case under Windows XP. If no selection is made, "Firmware" is selected automatically after approx. 2 seconds.

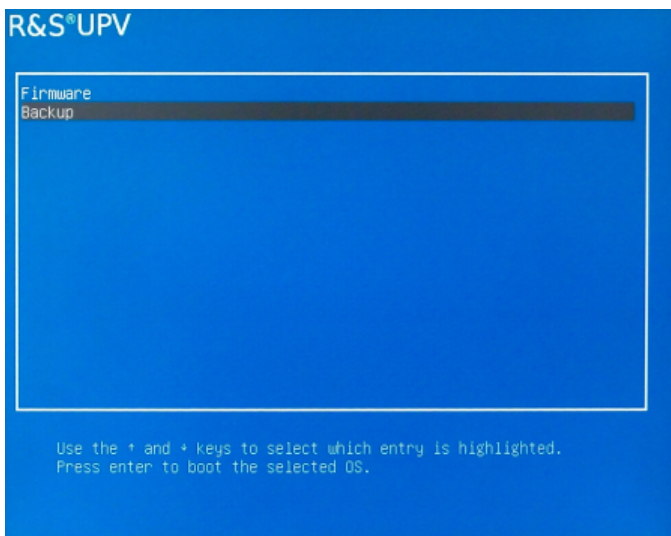

1. Switch the instrument off and on again. **Press the cursor keys multiple times during the boot phase to ensure that the Boot menu does not close after a short period of time.**
2. In the Boot menu, use the cursor keys to select "Backup".
3. Open the "Windows 7 Recovery and Backup Partition" menu by pressing [ENTER].

The menu shows the available selections for the recovery and backup partition:

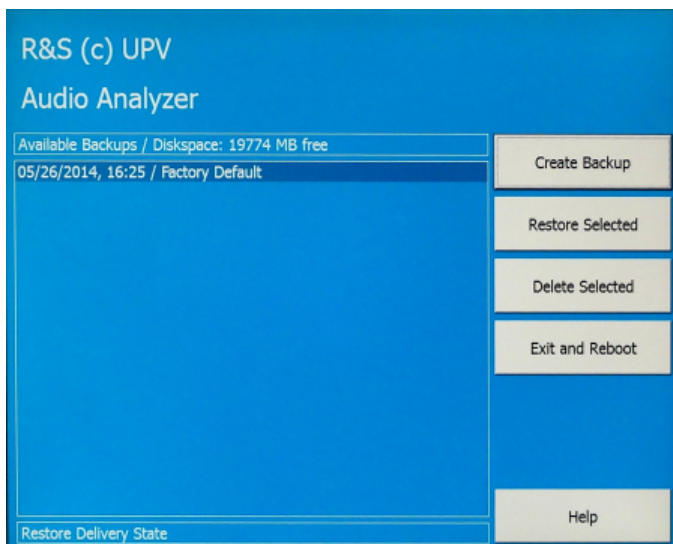

2.13.2 Restoring Factory Default

To restore the "Factory Default" state, select "Factory Default". Using the TAB keys, select "Restore Selected" and confirm with ENTER.

2.13.3 Restoring a "User Backup"

To restore a different backup, choose the selection list using the Shift+TAB key combination and select the desired backup using the "up/down" cursor keys. Select the "Restore Selected" field using the TAB key and confirm with ENTER.

2.13.4 Creating a "User Backup"

1. Using the cursor keys, select the "Create Backup" button in the Windows 7 Recovery and Backup Partition menu.
2. Open the "Create Backup" menu using the [ENTER] key.

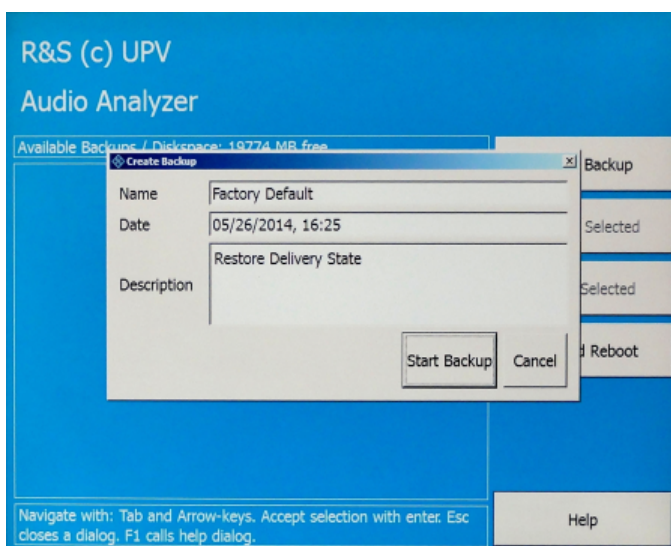

3. Entries must be made in the "Name" and "Description" fields; the entries shown here are intended as examples only (the date and time are entered automatically).
Select the "Start Backup" button using the TAB keys.
4. Confirm using the [ENTER] key.
The progress indicator updated in the "Capturing WIM Image..." field shows the status of the backup creation process:

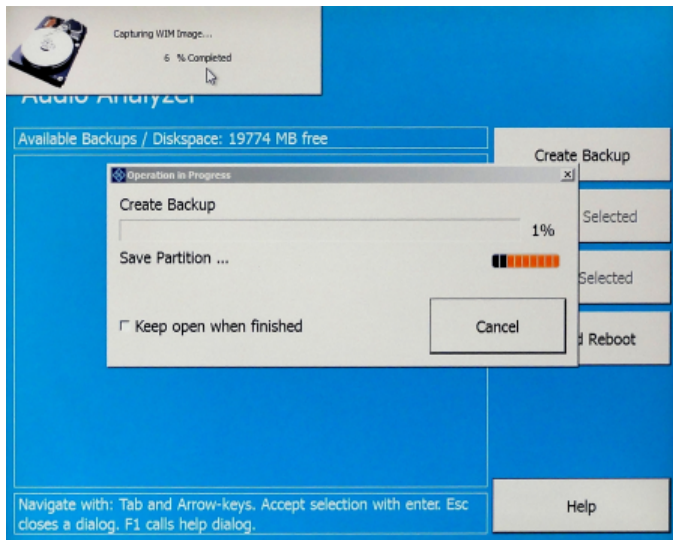

2.13.5 Deleting Backups

NOTICE

Deleting factory default setting

The factory default is treated in exactly the same way as a normal backup. Take care not to inadvertently delete the factory default!

Using the TAB keys, select the backup to be deleted. Then select "Delete Selected" and confirm with ENTER. To exit the Backup and Recovery system, select "Exit and Reboot" and confirm with ENTER. The instrument is rebooted.

3 Getting Started

3.1 Introduction - Getting Started

This chapter describes the manual operation of the R&S UPP audio analyzer. The information in this chapter also largely applies to the instrument designed primarily for use in systems provided that an external monitor, keyboard and mouse are connected to the instrument. More detailed information on the operation via external keyboard and mouse are explained in the [Chapter 4, "Manual Operation"](#), on page 114.

The R&S UPP audio analyzer is able to perform virtually all measurements occurring in the audio world, from frequency response measurements through distortion factor and spectral displays to the analysis of digital data streams. Several measurement functions can be carried out and displayed at the same time, whereby the measurements are performed perfectly simultaneously at all switched-on channels.

The R&S UPP performs all measurements using digital signal processing. Here, analog signals to be measured are first subjected to complex preprocessing on analog measurement modules before they are digitalized and fed to the digital measurement routines.

This concept offers numerous advantages, for example:

- The measurement methods at the analog and digital interfaces are identical.
- The measurement functions are available at both the analog and the digital interfaces.
- Operation at the analog and digital interfaces is the same.

The many available options mean that the R&S UPP can be adapted to perform a wide variety of different tasks. The basic version of the instrument has analog audio interfaces. A number of special measurement functions are also available, but only after the appropriate options have been installed (see the data sheet for details).

This chapter, "Getting Started", only describes the functions available in the basic version of the R&S UPP audio analyzer.

3.2 Important Information for Measurements

3.2.1 Maximum Output Voltage of the R&S UPP Generator

NOTICE

Possible Damage or Destruction of Input Circuits

The generator of the audio analyzer can generate analog output voltages with an RMS of up to 14 V. These levels can damage or even destroy sensitive input circuits.

There is an option in the "Generator Config" panel for limiting the analog output voltage. For measurements on sensitive circuits, it is advisable to set an appropriately low value in the "Max Voltage" field; this value then applies to all analog output signals, irrespective of the signal shape.

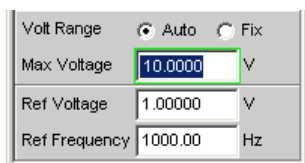

The pulse level of the digital audio signals can be up to 8.5 V. Although the risk of destruction is generally much smaller than for analog circuits, care must still be taken when making settings for activating digital circuits.

3.2.2 Avoiding Hum Loops

It is generally known in audio engineering that analog circuits must always be set up in such a way that hum signal pick-up is avoided. For this reason, it is important that a ground connection (grounding contact) be provided at only one point in the entire circuit.

Generator:

Pin 1 is not connected at the XLR connector. Symmetric (Bal) and asymmetric (Unbal) output are electronically floating (exception: Bal with switched-on output divider!). The output can be placed on ground (grounding it) by connecting Pin 3 to the ground.

Analyzer:

Starting with serial numbers 120100, 140100, 180100, Pin 1 is connected to ground via a capacitor, thereby connecting the pin with instrument ground only in relation to HF. This avoids formation of hum loops if the external connection connects pin 1 and 3 with each other.

To prevent any additional inadvertent ground connection being established via the generator, it is designed as electronically floating (exception: balanced operation with switched-on output divider). Pin 1 of the XLR connector is not connected. To prevent establishing any additional inadvertent ground connection via the audio analyzer when connecting the test setup with the analyzer inputs, Pin 1 of the XLR cable must not be connected with ground of the test setup (applies only to instruments with serial numbers lower than 1x0100, x = 2, 4, 8).

There are, however, some applications where the audio circuit to be tested is set up without any ground connection at all. It may be necessary to create a defined ground connection especially if hum pick-up is suspected. When connecting the UPP analyzer with the test setup via a standard XLR cable, it is grounded via the analyzer inputs if Pin 1 of the cable is connected with ground of the test setup.

3.2.3 Help System

The audio analyzer has a context-sensitive help system.

If you have a question while operating the instrument, pressing the [F1] key on the external keyboard opens a help page containing information on the currently highlighted parameter field.

From here it is possible to move to other help pages using the contents list, the index, scroll arrows and page-internal links. For more detailed information about help, see [Chapter 4.14, "Help System"](#), on page 193.

3.3 Brief Introduction to Operation

3.3.1 Windows User Interface and Controls

To provide the user with a familiar environment, operation of the R&S UPP is largely based on the Windows user interfaces. All panels, entry windows, etc. are made up of known elements.

Operation follows the same basic rules which apply to other Windows programs in use today. It is assumed that the user is familiar with these basic rules. This information is therefore not given in detail in this manual.

The panels, the menu bar, the buttons of the toolbar, and the softkeys (varying functions depending on the application) of the R&S UPP can be operated manually, provided that an external monitor, keyboard and mouse are connected.

After being switched on, the instrument is in the same state as it was before it was switched off. This applies to all setting parameters of the R&S UPP, including those not currently displayed on the screen.

A selection frame and dark markings around the entry fields indicate the current entry focus. Entries can be made in the element with entry focus.

3.3.2 The Display

The display is the central element for manually operating the R&S UPP. Both the instrument settings in the various panels and the measurement results are displayed here.

To make the various functions of the R&S UPP audio analyzer easier to operate, they are organized in a series of panels. The measurement results can be displayed as digital numeric values, data lists, in analog bar graphs or in result graphics. The user can freely choose the number of panels and the number of graphical windows to be shown in the display. The size of the windows can be changed within broad limits, whereby the font size, scaling and so on are adapted automatically (depending on the selected window).

Panels and display windows can be activated via the menu bar. The horizontal menu bar opens if the mouse pointer is moved to the left edge of the R&S UPP application. The toolbar opens when the mouse pointer is moved to the right edge.

Five display windows (or "screens") are provided so that the wealth of information can be better organized; these windows can be selected via the menu bar.

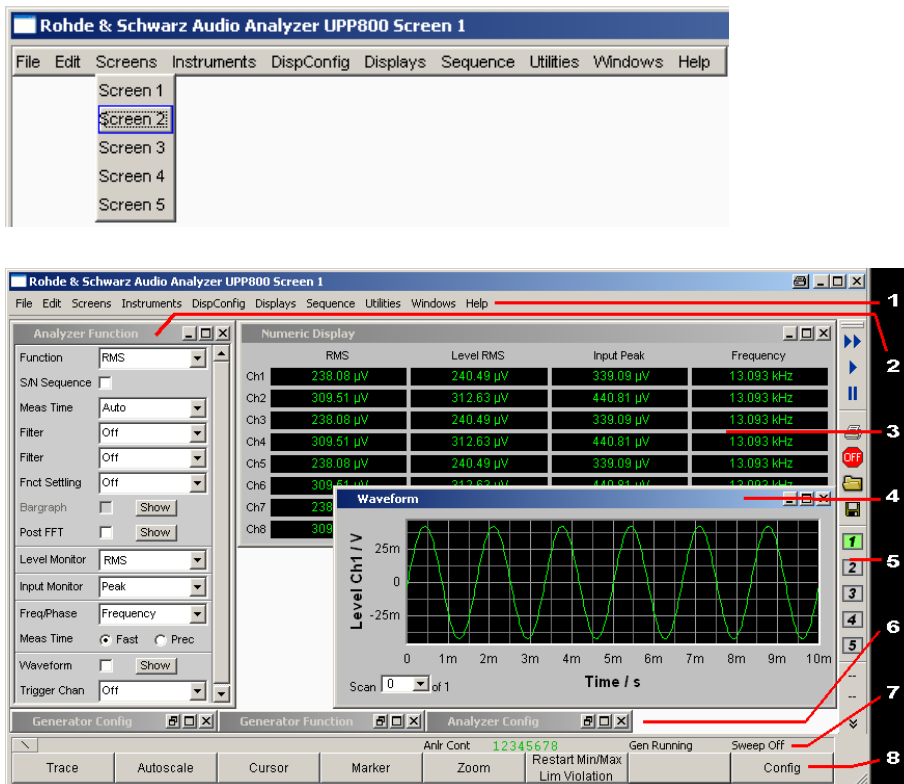

Figure 3-1: Screen with the essential elements

- 1 = Menu bar
- 2 = Panel
- 3 = Numeric display
- 4 = Graphical window
- 5 = Toolbar
- 6 = Reduced panels
- 7 = Status bar
- 8 = Softkey bar or WINBAR

The softkey bar is always shown at the bottom edge of the window.

In normal operating mode, the softkey bar is visible; it contains eight buttons which are assigned the functions available in the selection windows of the panels.

If there are more than 8 elements to choose from, the hidden elements in the selection list can be displayed by pressing the last softkey containing the >> symbol or the first softkey containing the << symbol.



3.3.3 Panels and Display Windows

The R&S UPP audio analyzer distinguishes between the following panels and display windows:

- **Quickstart panel** for quick launching of the most commonly used audio measurement tasks.
- **Panels** used to perform function settings.
- **Configuration panels** used for configuring how the measurement values are to be displayed.
- **Numeric display fields** for displaying the measurement values of the various measurement functions.
- **Combo displays** in which numeric measurement values can be supplemented by bar graphs and limit monitoring.
- **Graphical windows** in which measurement values are displayed in the form of diagrams.
- **Data lists** in which the measurement values are listed in tabular form.

Panels are moved to the currently visible screen by moving the mouse pointer to the left side of the screen to activate the menu bar, moving the mouse to "Instruments" or "DispConfig" and clicking the desired panel in the pulldown menu that opens.

Display windows are selected in the same way, except that they are listed under the "Displays" menu item.

The quickstart panel has a special role and can only be opened by clicking the rocket icon in the toolbar.

Each panel and display window is a separate window which can be either closed, opened or hidden. Panels/display windows are open if they are visible on the currently displayed screen; if the window is minimized and moved to the bottom edge of the screen, it is referred to as hidden.

As soon as a panel/display window can be operated, it can be moved on the screen and adjusted in size: Grab the panel at the title bar with the mouse and move it. The size of the panels can be changed by grabbing the edges or corners of the panels with the mouse and moving them.

The same panel / display window can be displayed in several screens at the same time. The display characteristics can be different for each of the screens; the content is, however, always the same.

3.3.4 Quickstart Panel

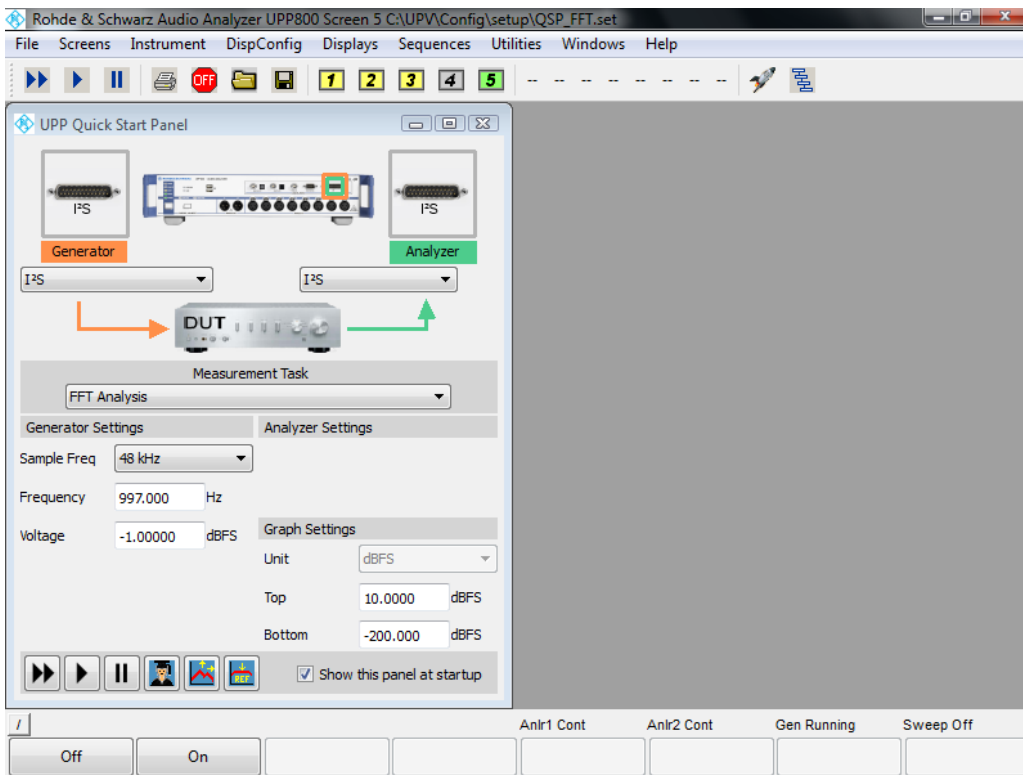

3.3.4.1 Introduction

Owing to the large number of measurement functions and setting options, beginners can often find the R&S UPP audio analyzer difficult to operate.

The **quickstart panel** provides assistance – it allows the inexperienced user to specify the outputs and inputs to which he wants to connect his "device under test" and, in particular, which audio measurement task he wants to carry out. A range of the most important audio measurement tasks are offered depending on the selected outputs and inputs. With just a few mouse clicks, the audio analyzer is automatically configured such that the desired measurement result appears on the screen numerically, as a trace or as a bar graph. Some entry fields allow the user to slightly modify the selected measurement function and adapt it to his own particular needs.

3.3.4.2 Opening and Closing Quickstart Panel

The quickstart panel is opened using the rocket icon on the toolbar:



The display immediately changes to screen 5 containing the quickstart panel.

As users become more familiar with the R&S UPP audio analyzer, they can use the expert icon  to change over from the quickstart panel to the normal user interface of the audio analyzer in order to access the full range of functions.

3.3.4.3 Description of Quickstart Panel Controls

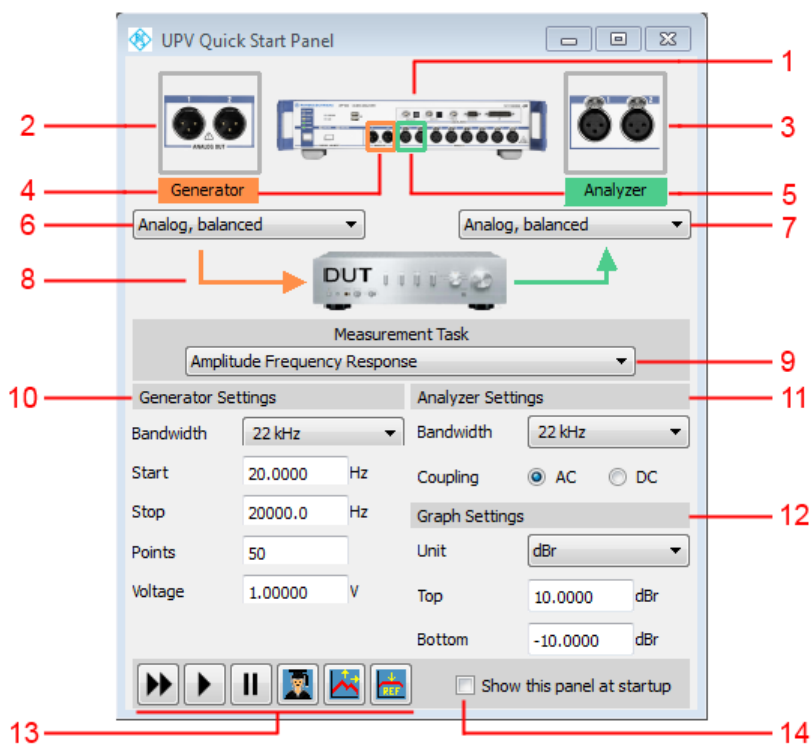

1. Image showing the current audio analyzers and its options.
2. Magnified view of the generator outputs that were selected using the combo box (6). If the outputs are on the rear of the instrument, "Rear" appears in red in the image.
3. Magnified view of the analyzer inputs that were selected using the combo box (7). If the inputs are on the rear of the instrument, "Rear" appears in red in the image.
4. Selected generator outputs on the instrument are highlighted in orange if they are accessible from the front.

5. Selected generator inputs on the instrument are highlighted in green if they are accessible from the front.
6. Combo box for selecting the desired generator outputs.

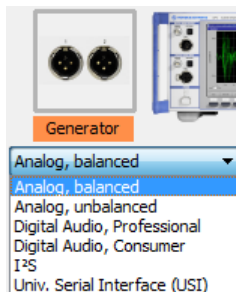

The available selection depends on the R&S UPP audio analyzer and its options. The entries are self-explanatory. Each time the generator output is changed, the combo box for selecting the desired measurement task (9) is reset (- - - - -) and a new measurement task must be selected.

7. Combo box for selecting the desired analyzer inputs.

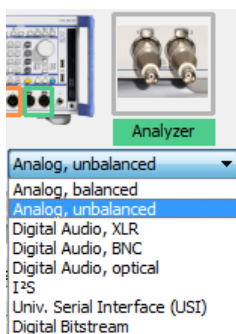

The available selection depends on the R&S UPP audio analyzer and its options. The entries are self-explanatory. Each time the analyzer input is changed, the combo box for selecting the desired measurement task (9) is reset (- - - - -) and a new measurement task must be selected.

8. Symbolic representation of a device under test (DUT) and its connection to the generator and R&S UPP audio analyzer without operating options.
9. Combo box for selecting the desired measurement task.

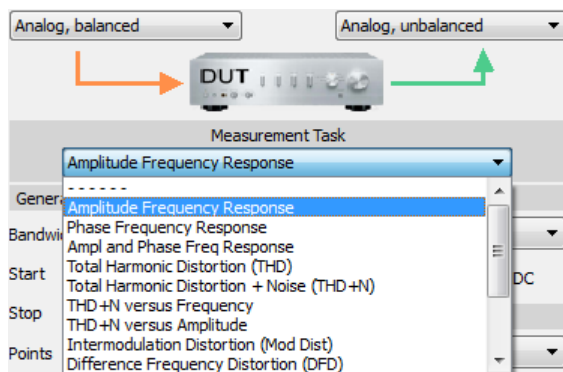

When the quickstart panel is called for the first time, no measurement task is selected; this is indicated by the dashed line.

The available selection depends on the settings made in the combo boxes (6) and (7). The entries are self-explanatory.

Example: If the "Analog, balanced" output has been selected in the combo box (6) for signal feed to the DUT, the measurement task "D/A Linearity" is **not** available as this is intended only for a digital output.

Selection of a measurement task sets up the R&S UPP audio analyzer accordingly without further action being required. With some measurement tasks, the measurement must be started by clicking the "Start continuous measurement" or "Start single measurement" button (13).

If a "Measurement Task" is selected in the quickstart panel, screens 1 to 4 display the settings as well as the numeric and/or graphical displays for the selected measurement tasks.

10. Entry fields for customizing the generator settings.

Example: Adjustment of the start and stop frequency for a frequency response measurement.

11. Entry fields for customizing the analyzer settings.

Example: Switching over the input coupling from AC to DC.

12. Entry fields for customizing the graphical display.

Example: Changing the unit on the Y axis.

13. 

Meaning of the buttons from left to right:

- **Start continuous measurement**
- **Start single measurement**
- **Pause / continue measurement**
- **Switch to expert mode:** Access to the full range of functions of the audio analyzer.

- **Autoscale graph:** One-off automatic scaling of the graphical display based on the current minimum and maximum values of the curves or bars.
- **Set to reference:** The Y value of the curve is used as a reference value once at the value 1000 Hz or 997 Hz (1000 Hz with analog measurements, 997 Hz with digital measurements), provided that the Y axis of the graphical display is shown in dBr. The curve is adjusted to 0 dBr at this point.

14. Show this panel at startup

When the audio analyzer is switched on, the quickstart panel is available in screen 5 without it having to be called specifically.

3.3.4.4 Tool tips

All the controls in the quickstart panel have so-called tool tips. If you hold the mouse pointer over a control for approx. 1 second, a brief description of the function appears.

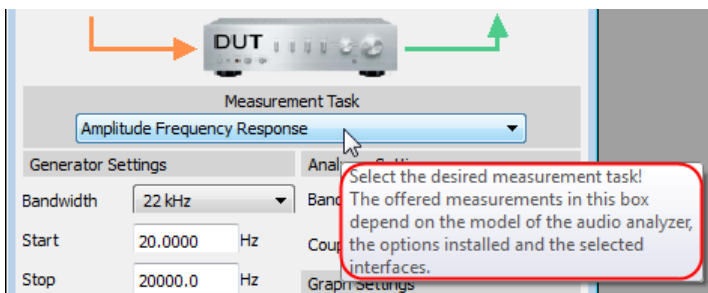

3.3.4.5 Messages During Operation

When the "Set to reference" button is clicked, messages that indicate problems can appear. For example, "Set to reference" is only effective if the Y axis of the graphical display is set to the unit dBr. If this is not the case, an info box indicating this appears.

3.3.4.6 Settings Outside Quickstart Panel

Settings made at a later time outside the quickstart panel, i.e. in the standard user interface of the R&S UPP audio analyzer, will result in inconsistencies between the settings in the quickstart panel and the actual setup of the R&S UPP audio analyzer; making subsequent settings outside the quickstart panel may, however, be necessary. The message "Operations outside Quickstart Panel detected! QSP

display might be different!" in the user info line (line above the softkey bar) alerts the user to this as a precaution. Reselecting a "Measurement Task" will cancel out any inconsistencies in the settings.

3.3.5 Structure of the Panels and Display Windows

The R&S UPP audio analyzer features the following panels with their main settings (for a detailed list of all panels with the most important setting parameters, see [Chapter 4, "Manual Operation"](#), on page 114).

Panels which can be selected via the "Instruments" menu bar button:

Generator Config	<ul style="list-style-type: none"> • Selection of instrument (analog or digital interfaces) • Configuration of channels and bandwidths • Reference values
Generator Function	<ul style="list-style-type: none"> • Selection of test signals • Sweep function • Frequency and level settings • Filter and equalizer • DC Offset
Analyzer Config	<ul style="list-style-type: none"> • Selection of instrument (analog or digital interfaces) • Configuration of channels, measuring bandwidth and pre-filter • Range configuration • Reference values • Start and trigger conditions
Analyzer Function	<ul style="list-style-type: none"> • Selection of measurement functions • Measurement speed and accuracy • Activation of filter and equalizer • Activation of Post FFT • Selection and settings for level monitor • Selection and settings for input monitor • Selection and settings for frequency, phase, group delay measurement • Selection and settings for waveform monitor
Filter	<ul style="list-style-type: none"> • Definition of filter properties
Auxiliaries	<ul style="list-style-type: none"> • Settings for the audio monitor
Switcher Panel	<ul style="list-style-type: none"> • Operation of one or more R&S UPZ audio switchers
Protocol Generator	<ul style="list-style-type: none"> • Settings for the R&S UPP K21 digital audio protocol

Panels which can be selected via the "DispConfig" menu bar button:

Function Config Level Monitor Config Input Config Freq Phase Config	These four panels contain settings for displaying measured values <ul style="list-style-type: none"> • in the numeric display fields • in the associated combo displays • and settings for limits, minimum values and maximum values
Sweep Graph Config FFT Graph Config Waveform Config Bar Graph Config	Up to four of each of these panels are available; they contain settings for displaying measurement values in the graphical windows, e.g. <ul style="list-style-type: none"> • One or two-channel display • Units, scaling, grid lines, etc. • Evaluation of minimum and maximum values • Entry of limit curves • Settings for cursors and markers

The measurement results of the audio analyzer are shown in the following display windows (for a detailed list of all panels with the most important setting parameters, see [Chapter 4, "Manual Operation"](#), on page 114).

Except for the Dig Analyzer Protocol window, the panels can be selected via the "Displays" button in the menu bar:

Numeric Display	<ul style="list-style-type: none"> • Display of measurement results for measurement function selected in Analyzer Function panel • Display of measurement results for level monitor and/or input monitor selected in Analyzer Function panel • Frequency measurement results, or frequency measurement result and phase / group delay measurement result
Funct Ch1 to 2 Lev Mon Ch1 to Ch2 Input Ch1 to Ch2 Freq Ch1 Freq / Phase	These combo displays are extensions to the numeric measurement displays; they show the respective numeric value plus the following: <ul style="list-style-type: none"> • Analog bar graphs • Limits • Minimum and maximum values
Sweep Graph 1 to 4 FFT Graph 1 to 2 Waveform Bar Graph 1 to 2	<ul style="list-style-type: none"> • Up to four of each of these display windows can be opened (depending on the window type) in order to display the scans of the different measurements • Graphical display shows one or two channels • The measurement results are displayed in the way defined in the associated configuration panel
Dig Analyzer Protocol	<ul style="list-style-type: none"> • The analyzed data of the digital audio protocol is displayed here (R&S UPP K21 option (digital audio protocol))

3.3.6 Basic Rules of Operation

The following basic rules are intended to simplify operation of the audio analyzer:

- Operating sequence in the panels from top to bottom**
 Changes to parameters of individual menu items may affect the selection or value range of menu items which are usually located further down (they affect the selection or value range in fields located higher up in only a few exceptional cases).
- Sequence Generator – Analyzer – Measured value display**
 Many setting parameters can be copied to other panels. For example, the sweep frequency settings can automatically be adopted as the scaling for the graph.

3.3.7 Function Selection and Value Entry

All functions and parameters are set in the panels.

Besides the mouse, the up/down cursor keys of the external keyboard can also be used for navigating.

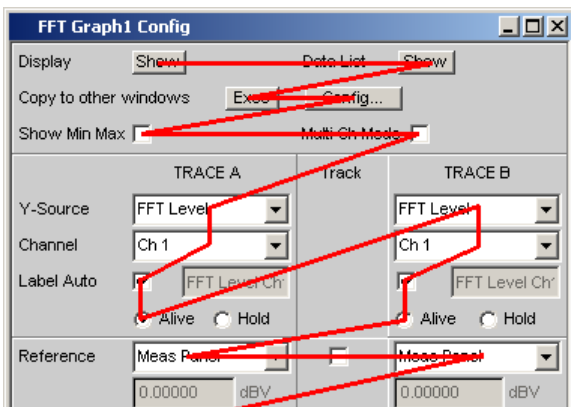

Panels can only be operated if they have the focus (indicated by the blue title bar).

Changing from one panel to another is done by clicking on the title bar.

Before settings can be made in a panel, the relevant parameter field must be highlighted, i.e. it must have the focus. This is indicated by a selection frame around the entry field.

The settings are made in the following ways:

Highlighting Controls

Click on the control with the mouse. The entry focus is indicated by a blue, green or magenta border.

Activating/deactivating functions



A checkbox is used to activate or deactivate functions. If the checkbox is active, the assigned setting is selected or enabled.

Toggling Functions



Radio buttons are used for functions which can be toggled between two settings. A black dot in the appropriate button indicates the selected status.

Only one of the two options can be active at any one time.

Select parameter

Clicking on the ▾ button next to the current selection displays a selection field. The drop-down parameter list is displayed below the selection field.

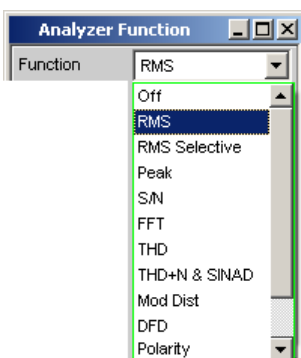

The selection is made by clicking the desired entry.

The parameter list can be exited without adopting the highlighted parameter by clicking anywhere on the screen or by pressing the [ESC] key of the external keyboard.

If the list is longer than the display, it is indicated by a scrollbar which can be grabbed and moved with the mouse.

Alternatively, parameters can also be selected using the softkeys.



The contents of the parameter lists are not fixed but vary depending on other settings selected.

Entering a Numeric Value

Numeric values can be entered or edited in these fields.

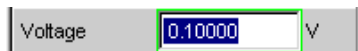

The following always applies: Entries outside the possible value range are not accepted; an audible warning is issued and the entry is changed to its permissible minimum or maximum value. The possible value range is displayed above the softkey bar.

Edit mode:

When the focus is moved to a numeric entry field, the system enters Edit mode, which is indicated by a green selection frame. The new value is entered via the external keyboard.

The numeric entry field is closed with:

- ENTER on the external keyboard or clicking in another panel area adopts the newly entered value.
- Pressing ESC on the external keyboard retains the old value.
- Softkeys – The selected unit is set and adopted together with the newly entered value.

The entered value is set in the hardware as soon as the numeric entry field is closed.

Direct mode:

It is also possible to enter the value in Direct mode. Changing to Direct mode is performed by pressing the ENTER key of the external keyboard; the color of the selection frame then changes to magenta.

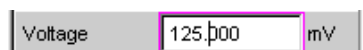

A digit can now be entered using the external keyboard; the digit at the cursor position is replaced.

In Direct mode, every setting change is immediately passed on to the hardware and executed. Direct mode can be exited using the ENTER or ESC key on the external keyboard.

Entering/Changing the Unit of a Value

The unit of a numeric value is displayed next to the entry field.



When the value is entered, all units available for the respective function are offered on the softkey bar (on more than one level where necessary). The entry can be completed by selecting the unit using a softkey.

This is done differently depending on the selected mode:

- In Edit mode, the newly entered numeric value is adopted and set together with the selected unit.
- In Direct mode, the physical value (number with the previously selected unit) is converted to the newly selected unit and adopted as the new numeric value.

Information on Using Reference Values

The audio analyzer allows reference values to be set in various places. These reference values are used as a basis for settings for other parameters.

The example below explains these interdependencies:

A reference voltage ("Ref Voltage") can be set in the "Generator Config" panel. The actual output voltage is set in the "Generator Function" panel where the unit is dBr, i.e. it is possible to enter the output voltage in dB relative to this reference value.

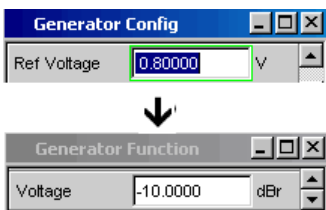

Entering Alphanumeric Values

When the focus is moved to a text entry field, the system enters Edit mode, which is indicated by a green selection frame.



If the complete text (e.g. for graph labels) is to be newly entered, simply begin entering characters using the external keyboard; the old text is deleted automatically when the first key is pressed.

The backspace/delete key can be used during the entry to delete the character to the left/right of the cursor.

The text entry field is closed with:

- ENTER – The newly entered text is adopted
- ESC – The old text is retained.

Display Fields

Sometimes it is very useful for operators to receive additional information about their settings.



Display fields inside the panels are used in such cases. These fields are shown in gray and cannot be accessed. They always contain valid values and therefore always show settings active in the background; the fields are updated as soon as a setting in the associated parameter field is changed.

Adopting Parameters

In many cases, settings are to apply e.g. to both measurement channels or to both traces. Here the R&S UPP provides multi-column panels which allow settings to be transferred from the left-hand to the right-hand column without the parameter having to be entered a second time.

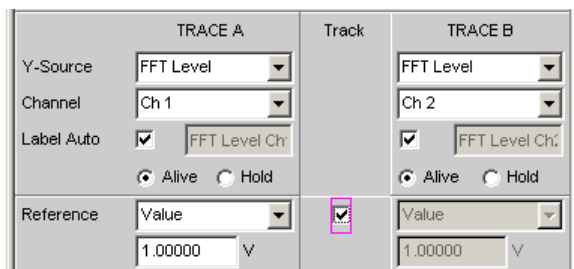

If the track box is activated, all of the settings within the function group apply to both columns. All fields with transferred settings in the right-hand column are shown as display fields. They appear gray and cannot be accessed while the track function is active. If a setting is changed in the associated parameter field in the left-hand column, this change is also shown in the display field in the right-hand column.

3.3.8 Input Help

Information on the possible entries is given at the bottom of the screen above the softkey bar. The units offered in the softkey bar and the limits specified in the "Valid Range" field always refer to the highlighted parameter field. The valid value range is given in the unit currently selected.

Entries outside the specified value range are not accepted; an audible warning is issued and the entry is changed to its permissible minimum or maximum value.



The specified ranges for value entries always take the current status of the instrument into consideration. They are therefore not constant and depend on the presets already configured for other parameters.

Below is an example for entering the generator output voltage; additional units can be displayed using the >> button:



3.3.9 Measurement Functions and Displaying Measurement Results

The audio analyzer offers various types of measurement windows for displaying the results of the numerous measurement functions. The measurement results can be displayed as digital numeric values, in analog bar graphs, in result graphics or in data lists. The user can open any number of measurement windows on the screen.

- **What** (which measurement function) is measured and **how** (which measurement method) measurement is performed, is preset in the "Analyzer Function" panel.
- The **configuration panels for measured value display** are used to determine how the measurement results are presented (i.e. which unit, how many digits, etc.). A series of panels for the different measurement windows are provided for this purpose.
- The results are finally displayed in the various **measurement windows**.

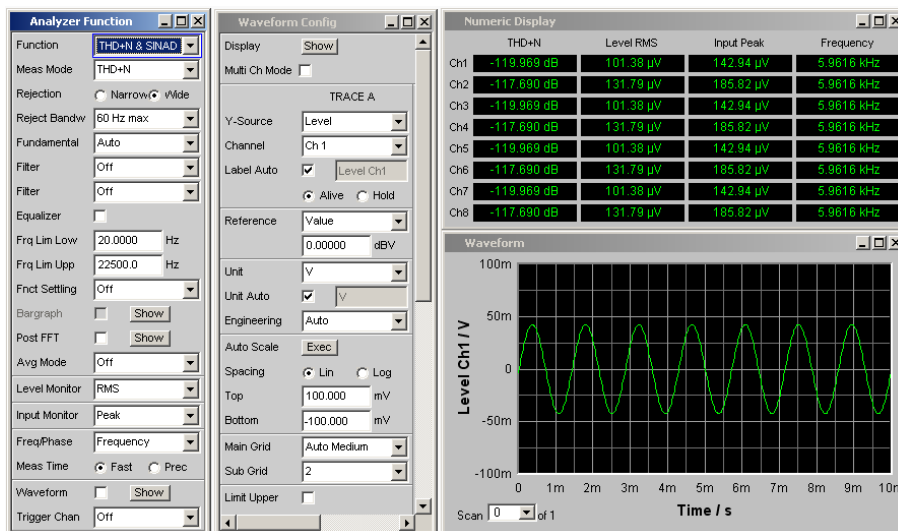

3.3.9.1 Numeric Display Field

The numeric display field provides a clear overview of the numeric values from various analyzer functions and displays a maximum of 8 numeric value results from the "Analyzer Function" panel. The individual columns are permanently assigned, from left to right:

- Column 1:
Measurement results of the function which is set in the "Function" field of the "Analyzer Function" panel.
- Column 2:
Measurement results for the set "Level Monitor" function.
- Column 3: Measurement results for the "Input Peak" function.
- Column 4:
Display of either the frequency measurement result or, if "Freq & Phase" or "Freq & GrpDel" is set, display of the frequency measurement result in the first row and display of the phase or group delay measurement in the second row.

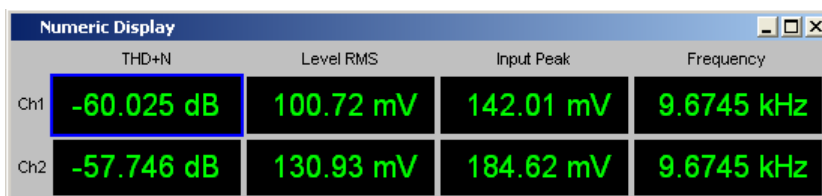

Combo Display

The combo display is used if the numeric value of a measurement result is to be supplemented by analog bar graphs, limit monitoring or the storage of maximum and minimum values.

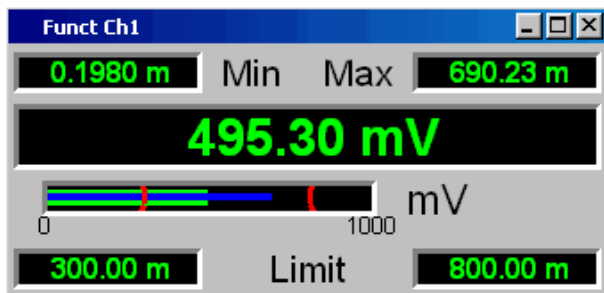

The free selection and free scalability mean that especially important or critical results can be monitored and tracked even when viewing the screen from a relatively long distance.

The easiest way to open combo displays is by double-clicking on the corresponding measurement display in the numeric display field.

Configuring the Numeric Display Field and Combo Display

The settings for the individual columns of the numeric display field or for the combo displays are made in the following four configuration panels which can be opened using the "DispConfig" button in the menu bar:

- "Funct Config"
- "Lev Mon Config"
- "Input Config"
- "Freq / Phase Config"

Channel 1		Channel 2	
Display	Show	Show	
Copy to Ch 2	Exec		
Unit	dBFS	dBFS	
Unit Auto	<input checked="" type="checkbox"/> dBFS	<input checked="" type="checkbox"/> dBFS	
Engineering	Auto	Auto	
Resolution	5dig / 0.001 dB	5dig / 0.001 dB	
Reference	Value		
	1.00000 FS		
Auto Scale	Exec	Exec	
Spacing	<input checked="" type="radio"/> Lin <input type="radio"/> Log	<input checked="" type="radio"/> Lin <input type="radio"/> Log	
Left	0.00000 dBFS	0.00000 dBFS	
Right	10.0000 dBFS	10.0000 dBFS	
Main Grid	Auto Fine	Auto Fine	
Sub Grid	Off	Off	
Limit Lower	<input type="checkbox"/>	<input type="checkbox"/>	
Limit Upper	<input type="checkbox"/>	<input type="checkbox"/>	
Show Min Max	<input checked="" type="checkbox"/>	<input checked="" type="checkbox"/>	

Graphical Window

The most informative way of displaying measurement results is to use a two-dimensional graph. The audio analyzer makes a distinction between the following graphical windows:

- Sweep Graph
- FFT Graph
- Waveform
- Bar Graph

These windows can be set using the associated configuration panels.

All graphical displays can be evaluated using horizontal and vertical cursors; markers are used to identify important measurement points. A broad range of softkey control functions can be used to scale graphs, to display sections of graphs, and to perform many other tasks.

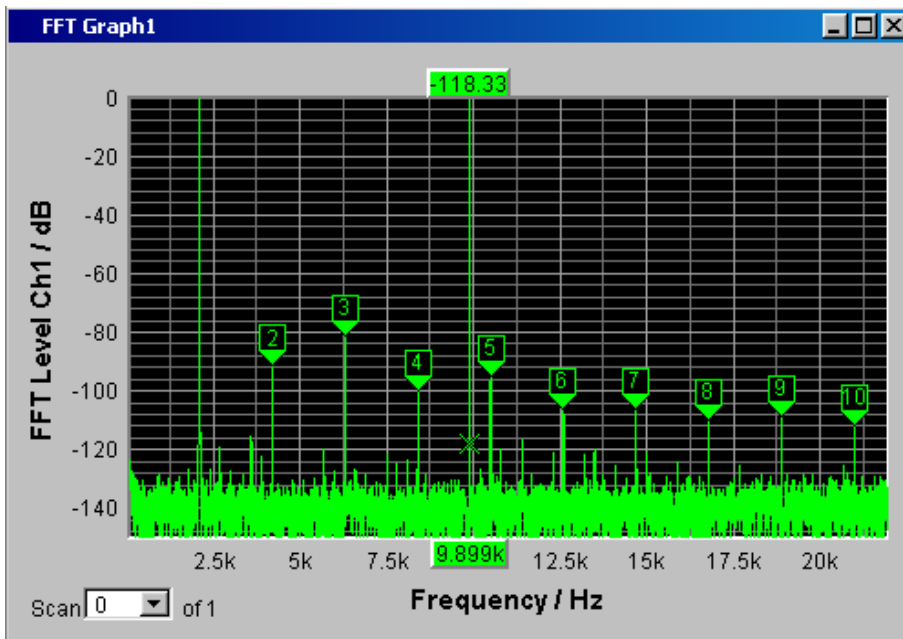

3.4 Introduction to Instrument Operation Using Examples

3.4.1 Measuring the Frequency Response of an Amplifier, Equalizer, etc.

This example is based on the factory settings of the audio analyzer. It explains the changes made in the individual panels to set up the measurement and describes how to graphically display the measurement results. Finally, the example shows how to save the defined measurement setup so that it can be used again for other applications.

1. Step: Loading the factory settings
The easiest way to load the factory setting of the instrument is by opening the menu bar with the mouse and clicking on File, followed by Preset (Load Default).
2. Step: Setting the required generator signal

Introduction to Instrument Operation Using Examples

- a) The basic settings for configuring the generator are made in the "Generator Config" panel.

The frequency response is usually measured on both channels; this is already configured in the "Channel" field.

From serial numbers 120100, 140100, 180100 and depending on the DUT, the "Output Type" field allows switching over to balanced circuitry with the optional output impedance of 25 Ω or 600 Ω .

If needed, click on the corresponding parameter field and perform the desired selection.

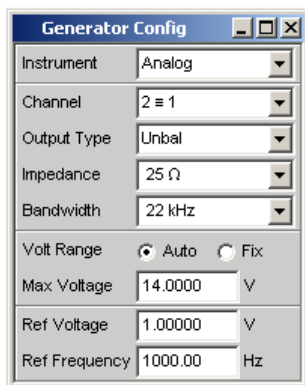

- b) A maximum signal frequency of 22 kHz is generally the correct setting here.

The following settings are also suitable for the majority of applications and do not have to be adjusted unless necessary.

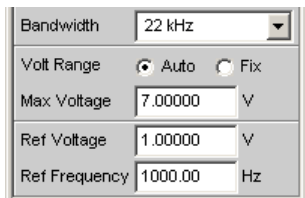

This completes the settings in the "Generator Config" panel.

- c) Next, the "Generator Function" panel is activated using the mouse. Sine-wave signals are required; this setting is already selected. To be able to measure the frequency response, the sine-wave signal must be swept in the frequency. A fixed frequency of "1 kHz" is preset in the default instrument setup. To activate the sweep, select the "Sweep Ctrl" field, open the parameter list and select the desired setting.

Introduction to Instrument Operation Using Examples

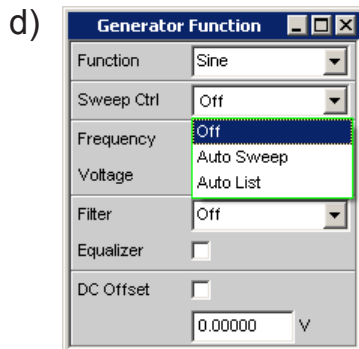

The parameter list closes and a number of additional fields appear in which further sweep parameters can be set.

- e) The "Next Step" field remains set to "Anlr Sync". This setting causes the next sweep step to be triggered as soon as a valid measurement result is available in the analyzer part. This synchronization optimizes the sweep speed.

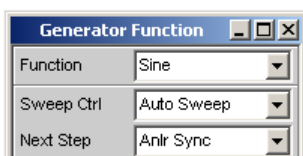

- f) The sweep variable must now be specified in the "X Axis" field. Frequency is already preset here (as required in this example). No other sweep variable is required; therefore, the "Z Axis" field also remains unchanged and set to "Off". The "Spacing" selection field is used to select the algorithm for advancing through the sweep points. This can be done using a linear or logarithmic step size; the number of individual sweep points ("Points") or the step size from point to point ("Steps") can be set. This selection field is factory-set to "Log Points"; this is the usual setting for frequency response measurements.

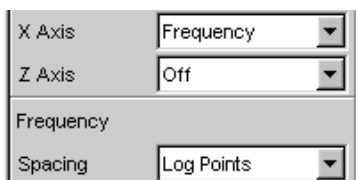

Introduction to Instrument Operation Using Examples

- g) The values for the start and stop frequency of the sweep must be entered in the two fields "Start" and "Stop".

Highlighting the desired field gives it the green selection frame. The desired frequency value can now be entered directly (here: 20 Hz). Pressing the ENTER key adopts the value and adjusts the hardware accordingly.

Start	<input type="text" value="20.0000"/>	Hz
Stop	<input type="text" value="20.0000"/>	kHz

The possible value range is given above the softkey bar. Entries outside the specified value range are not accepted; an audible warning is issued and the entry is changed to its permissible minimum or maximum value.

Valid Range is 100mHz to 21.75kHz	
Hz	kHz

As soon as the value entry field is highlighted, all available units are displayed on the softkey bar; additional hidden units can be shown using the >> button. Value entry can also be completed by pressing the softkey labeled with the desired unit; this is a particularly useful feature if a value is to be changed to a different unit.

The value for the stop frequency is entered in the same way (here 20 kHz).

- h) The number of desired sweep points must be entered in the "Points" field, 30 points are preset here. Up to 1024 points can be selected (50 points are entered in this example). This generally provides an adequate number of measured values without making the overall test sequence too long.

Start	<input type="text" value="20.0000"/>	Hz
Stop	<input type="text" value="20.0000"/>	kHz
Points	<input type="text" value="50"/>	

Introduction to Instrument Operation Using Examples

- i) The desired output voltage for the measurement is entered in the "Voltage" field; once again, the field must be highlighted before the value can be entered. The value range is again displayed above the softkeys and the available units are shown in the softkeys.

The remaining fields are not relevant for this example. Configuration of the generator is therefore complete.

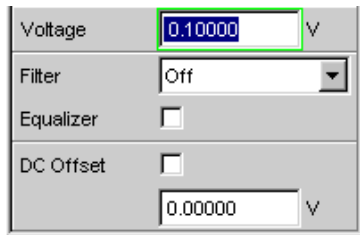

3. Step: Selection of required measurement

- a) The basic settings for configuring the analyzer are made in the "Analyzer Config" panel.

In order to operate the panel, it must be selected and have the focus. The frequency response is usually measured on all channels; this is already configured in the Meas Channel field. The following parameter fields occur only once and are set to "Track" and affect all channels.

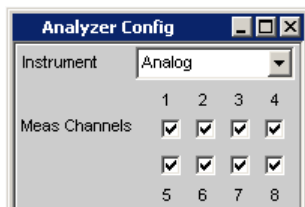

Introduction to Instrument Operation Using Examples

- b) The "AC/DC Coupl" parameter field is set to "Track", i.e. AC and DC coupling can be switched as necessary for all channels using the two radio buttons. If the coupling is to be set individually for each channel, then the AC/DC Coupl parameter field must be set to Split.

The fields for the measurement bandwidth are already preset with the appropriate setting; no prefilter is required here.

The signal to be measured is fed via the balanced input sockets.

The auto-range function for all channels ("Range = Track") is generally the correct setting here. If range is to be set individually for each channel, then the "Range" parameter field must be set to "Split".

The default settings in the following fields are also correct.

This completes the settings in the "Analyzer Config" panel.

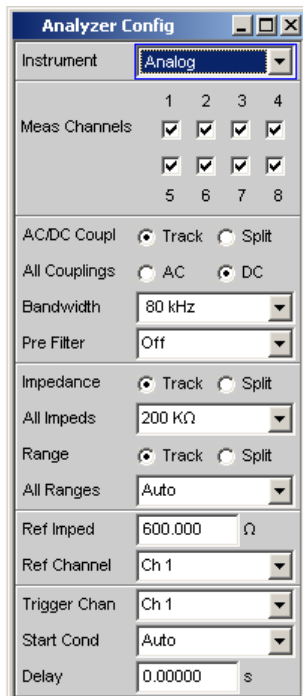

c) The following are set in the Analyzer Function panel:

- **what** is measured (which measurement function) and
- **how** measurement is performed (which measurement method)

The RMS value of the voltage must be measured for the frequency response measurement described here; the required setting ("RMS") is already preselected.

The measurement time for each individual measurement point is selected in the "Meas Time" field. The default instrument setting here is Auto which means that the measurement time is automatically adapted to the input frequency, i.e. the test sequence speeds up as the frequency increases. This setting can (with just a few exceptions) be used for the majority of applications.

If the integrated generator is used for measuring the frequency response (as in this example), the setting "Gen Track" should be used. The measurement time is then automatically adapted to the frequency generated in the generator. The frequency information from the generator is passed on directly to the analyzer. The analyzer then adjusts its measurement time to precisely one period (or to an integer multiple of one period). The advantage of this method is maximum measurement speed with maximum accuracy.

All other parameter fields are not relevant for this example. This completes the settings in the "Analyzer Function" panel.



4. Step: Displaying the measurement results – Numeric measurement display
- In the default instrument setup, the numeric measurement display is also already open. If the DUT is correctly connected to the audio analyzer, measured values will already be displayed.

	RMS	Input Peak	Frequency
Ch1	348.38 mV	496.18 mV	80.000 Hz
Ch2	447.38 mV	637.18 mV	80.000 Hz

The panels for configuring the measured value display are used to determine how the measurement results are presented (i.e. which unit, how many digits, etc.). A series of panels for the different measurement windows are provided for this purpose.

The "Function Config" panel is shown here as an example; the first column of the numeric measurement display is configured in this panel, i.e. the display fields which show the measured level values for the frequency response measurement described here.

The unit for the numeric measurement displays is set in the Unit field.

The Engineering parameter is used to determine whether the display automatically toggles between μV , mV and V, for example, or whether other unit formats are desired.

If the measurement results are to be displayed as relative values, they are referred to the reference value set in the Reference field.

Other parameter fields in this panel are used to set limits and to display extreme values; see also [Chapter 4, "Manual Operation"](#), on page 114 as well as the operating manual on the documentation CD.

Function Config	
Channel 1	
Unit	V
Unit Auto	<input checked="" type="checkbox"/> V
Engineering	Auto
Resolution	3dig / 0.1dB
Reference	Value
	0.00000 V

5. Step: Starting the sweep

Although the analyzer is already supplying measurement results, the status message "Sweep Waiting" above the softkeys indicates that the sweep has not yet been started although it has been configured in the "Generator Function" panel.

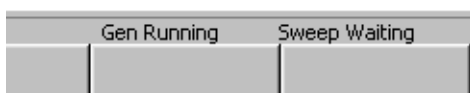

Introduction to Instrument Operation Using Examples

- a) This is done with the "Start" button from the toolbar (the two double arrows) or the "Ctrl F5" key on the external keyboard. The status message "Sweep Run Cont" informs the user that when this key is pressed the sweep will start and be repeated continuously.
 - b) The "Stop/Cont" button of the toolbar (two vertical bars) or the "Ctrl F7" key of the external keyboard can be used to interrupt the sweep process at any time ("Sweep Stopped" status message), pressing the key again continues the process.
 - c) The "Single" button of the toolbar (single arrow) or "Ctrl F6" of the external keyboard can be used to start the sweep only **once**; after the sweep cycle is complete, the status field indicates "Sweep Terminated".
6. Step: Displaying the measurement results – Graphical windows
- The results of a frequency response measurement are usually displayed graphically with the measured output voltage values of the DUT being plotted on the frequency axis.
- The following settings are required for this:
- a) To avoid overloading screen 1 with too many panels, change to screen 5 to display the graphical representation.
 - b) Open the menu bar and, from the selection list under the "DispConfig" button, select the "Sweep Graph 1 Config" panel. As explained above, the way in which the measurement results are presented is determined in the configuration panels. Each graphical window has its own configuration panel. The "Sweep Graph 1 Config" panel required here has two columns, but only Trace A is shown to provide a better overview.

```
Sweep Graph1 (closed)
Sweep Graph2 (closed)
Sweep Graph3 (closed)
Sweep Graph4 (closed)
FFT Graph1 (closed)
FFT Graph2 (closed)
```

Introduction to Instrument Operation Using Examples

- c) The associated graphical window can be opened using the "Show" button in the "Display" field. The window appears in the same screen so that the effect of the following settings can be observed directly.

In each graphical window, one or two traces (Trace A and Trace B) can be plotted on one x-axis. Each trace can consist of a large number of scans. In this example, only one single scan is to be displayed; the "Scan" field can therefore remain set to "Single".

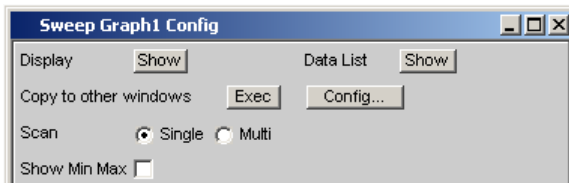

- d) The traces can display the results of the different measurements available in the R&S UPP.

For the frequency response measurement, the measurement results for the measurement function selected in the Function field in the Analyzer Function panel (here the RMS measurement) must be displayed graphically. For trace A, the Y source field is set to the **Function** result and the measurement channel to be displayed is selected with the Channel = **Ch1** parameter field underneath it (this is already preset in the default setup).

The "Alive" setting means that the results are displayed continuously; the "Hold" setting "freezes" the traces.

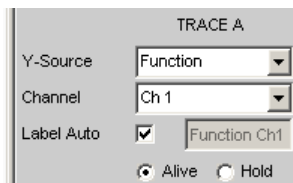

- e) The units to be used for the measured values on the y-axis are set in the next section.

If the unit used in the numeric display window is also to be used in the graphical window, the "Unit Fnc Track" checkbox must be activated. If this is not the case, a unit can be selected from the parameter list next to the checkbox.

The "Engineering" parameter is used to determine whether the display automatically toggles between μV , mV and V , for example, or whether other unit formats are desired.

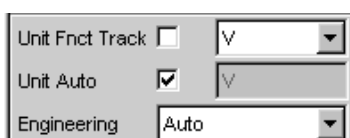

Introduction to Instrument Operation Using Examples

- f) All the other default instrument settings are correct and allow a result to be displayed immediately in the form of a graph. If the sweep is started with the "Start" or "Single" button from the toolbar or "Ctrl F6" or "Ctrl F7" of the external keyboard, the trace appears in the graphical window.
- g) The scaling will probably need to be adjusted. Actuating the "Exec" button in the line "Autoscale" rescales the graph on the basis of the measured minimum and maximum values so that the entire trace fits in the graphical window.

The end values for the y-axis can, however, also be entered in the two fields "Top" and "Bottom".

- h) The default settings for the x-axis are also mostly correct for this example: By selecting a frequency sweep in the Generator Function panel, the x-axis is automatically defined as the frequency axis with the unit Hz. If "Auto" is set in the "Scaling" field, the start and stop frequency of the sweep defined in the "Generator Function" panel is automatically used as the start and end value for the x-axis.
- The "Lin" setting in the "Spacing" field is unsuitable for this example. Since a sweep with logarithmic step size has been selected for this measurement, the x-axis should also be subdivided logarithmically.

7. Step: Using a relative unit in the graphical window

The settings so far made allow the frequency response of the DUT to be displayed graphically but not in a way that conforms to standards.

In the case of frequency response measurement, the relevant standards stipulate that the deviations of the output voltage must be plotted over frequency, whereby the output voltage of the DUT at the reference frequency 1 kHz (for analog measurements) is used as the reference level.

The following settings in the "Sweep Graph 1 Config" panels are used to adapt the graph for this measurement example:

Introduction to Instrument Operation Using Examples

- a) A default reference value of 1 V is set in the Reference field.

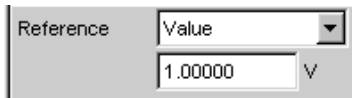

This value must be replaced by the output voltage value of the DUT measured with the reference frequency of 1 kHz.

The R&S UPP offers a very simple way of doing this:

If the parameter list is opened in the "Reference" field, it is possible to select the setting "Ref 1000 Hz". With this setting, the value measured at this frequency is determined (if necessary by means of interpolation between the measured values at the two adjacent frequencies) and used as the reference value.

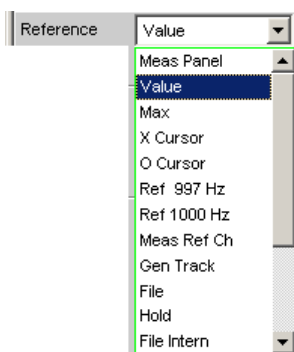

- b) All that remains is to select the unit dBr in the "Unit Fnct Track" field. All measured values are then displayed in dB relative to the reference value selected above. This satisfies the standards defining frequency response measurement.

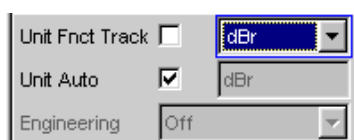

- c) The y-axis must now be scaled according to requirement, e.g. from +20 dBr to -20 dBr.

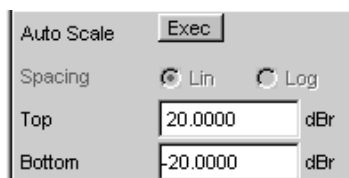

Introduction to Instrument Operation Using Examples

- d) If the measurement result of the second channel has been selected for Trace B, the graphical display for the measured frequency response of the DUT may look like the example shown below.

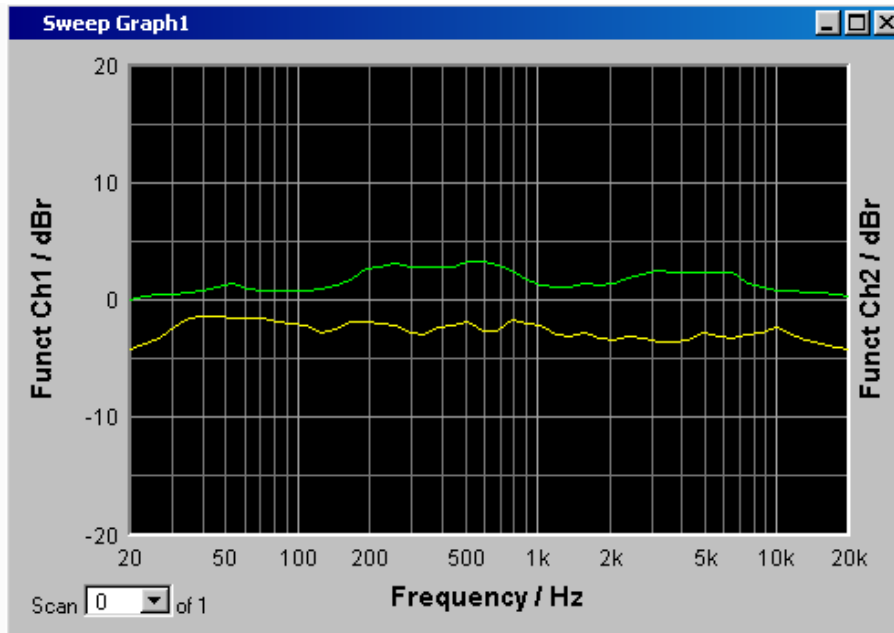

8. Step: Saving this instrument setup

- a) The menu bar, "File", "Save Setup as" opens a window for saving files.
- b) The desired file name can now be entered with the external keyboard. The file extension is assigned automatically once the file name has been entered (here .SET); it is advisable to use this automatic assignment function as it prevents entry errors.
- c) If this instrument setup is to be used again at a later time, simply open the menu bar and click on "File", "Load Setup" to be able to load this setup again in the File window.

3.4.2 Measuring Total Harmonic Distortion (THD+N) of a DUT

This example is also based on the factory settings of the audio analyzer. However, only the settings in the individual panels which differ from the settings in the previous example are explained.

1. Step: Loading the factory settings

- a) Load the default setting by opening the menu bar and selecting "File", "Preset (Load Default)".

2. Step: Setting the required generator signal

Introduction to Instrument Operation Using Examples

- a) In the "Generator Config" panel, the basic settings for configuring the generator in this example are the same as those set for the frequency response measurement described in the previous section. Depending on the DUT, "Output Type" may have to be switched to balanced circuitry.

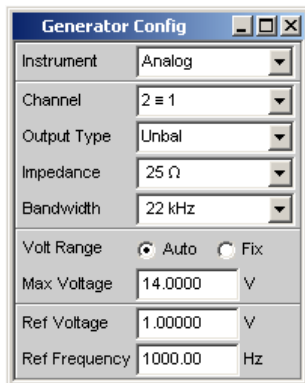

- b) Next, the "Generator Function" panel is activated. Sine-wave signals are required. This setting is one of the presets. The total harmonic distortion is often only specified for the reference frequency 1 kHz (for analog applications). Fixed frequencies are therefore used for measurement; as a result, "Sweep Ctrl" must remain set to Off.

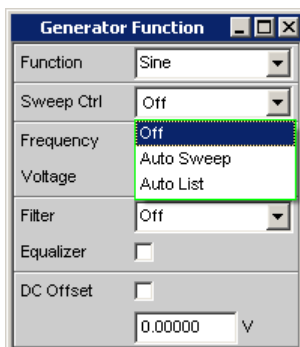

- c) The frequency 1 kHz is already preset in the default instrument setup. Only the output level required for the measurement may have to be adjusted (in the Voltage field). The remaining fields are not relevant for this example. Configuration of the generator is therefore complete.

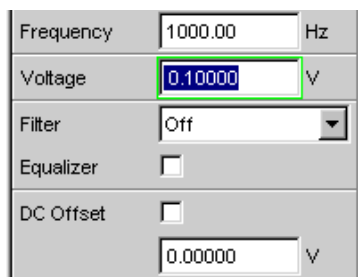

3. Step: Selection of required measurement

- a) The basic settings for configuring the analyzer are again made in the "Analyzer Config" panel.

These settings are made in the same way as shown in the previous example.

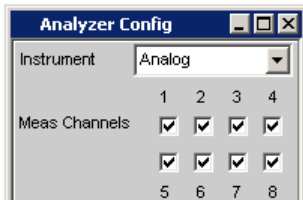

- b) Next, the "Analyzer Function" panel is activated.

The measurement function and measurement method are set in this panel. First, the measurement function is selected by opening the parameter list and selecting the item THD+N & SINAD.

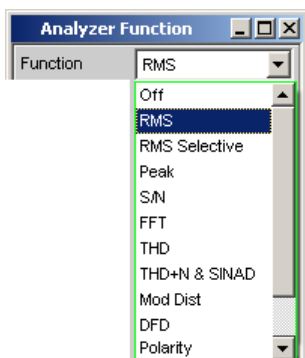

- c) In the next field "Meas Mode", various modes for distortion factor measurement can be selected; the presetting "THD+N" is correct for this example.
- d) With the THD+N measurement, the fundamental of the signal to be measured is suppressed using a notch filter. The audio analyzer can automatically determine the fundamental from the spectrum and adjust the notch filter to it ("Fundamental Auto").

Filter and Equalizer are only required in exceptional cases.



Introduction to Instrument Operation Using Examples

- e) The calculation for harmonics and noise components can, if necessary, be restricted to within band limits which can be entered in the two fields "Freq Lim Low" and "Freq Lim Upp".

Frq Lim Low	20.0000	Hz
Frq Lim Upp	22500.0	Hz

All other parameter fields are not relevant for this example. This completes the settings in the "Analyzer Config panel".

4. Step: Displaying the measurement results – Numeric measurement display
- a) In the default instrument setup, the numeric measurement display is already open.

If the DUT is correctly connected to the audio analyzer, the measured values for the total harmonic distortion can be read off in the first column. In the default setup, THD+N values are given in dB; if a display in % is desired, this unit can be changed in the "Function Config" panel.

	THD+N	Input Peak	Frequency
Ch1	-123.794 dB	-80.722 dBFS	1.9459 kHz
Ch2	-121.515 dB	-78.443 dBFS	1.9459 kHz

5. Step: Displaying the spectrum in the graphical window
- Display of the numeric value alone is sufficient for the majority of harmonic distortion measurements. Here, however, the spectral composition of the output signal at the DUT is also to be analyzed. With the audio analyzer, it is possible to follow up all distortion measurements with an FFT analysis. The necessary settings for this are explained in the following section:

Introduction to Instrument Operation Using Examples

- a) In the "Analyzer Function" panel already used for configuring the THD+N measurement, an FFT analysis to be performed following the measurement can be set after the actual measurement function has been selected. To do this, activate the "Post FFT" checkbox. The size of the FFT can be adjusted if necessary.

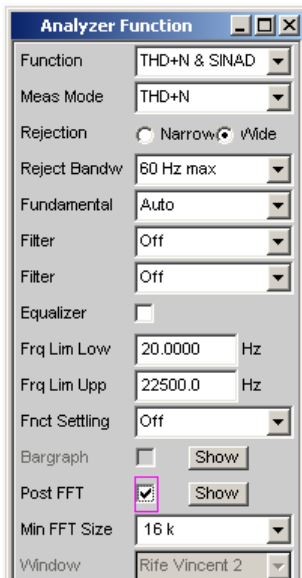

- b) To graphically display the results of the FFT analysis, first change to screen 5, which is empty in the default setting.
- c) Open the menu bar and from the selection list under the "DispConfig" button, select the "FFT Graph 1 Config" panel. As explained in the previous example, the way in which the measurement results are presented is determined in the **configuration panels**. Each graphical window has its own configuration panel. The "FFT Graph 1 Config" panel required here has two columns; to simplify matters, only Trace A is shown in the example.

Sweep Graph1 (closed)
 Sweep Graph2 (closed)
 Sweep Graph3 (closed)
 Sweep Graph4 (closed)
 FFT Graph1 (closed)
 FFT Graph2 (closed)

- d) The associated graphical window can be opened using the "Show" button in the "Display" field. The window appears in the same screen so that the effect of the following settings can be observed directly.

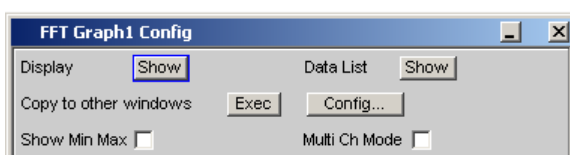

Introduction to Instrument Operation Using Examples

- e) In each FFT window, one or two traces (Trace A and Trace B) can be plotted on the frequency axis.

In this example, the level measurement results of the FFT analysis are to be displayed on a graph. For Trace A, the "Source" field is therefore set to "FFT Level" and "Channel" to Ch1 (this is already preset in the default setup).

The "Alive" setting means that the results are displayed continuously; the "Hold" setting "freezes" the traces.

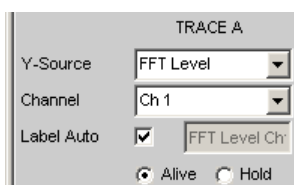

- f) The settings for the unit, y-axis scaling and grid are already preset in the default setup; a result should therefore be visible. If necessary, these settings must be adjusted.

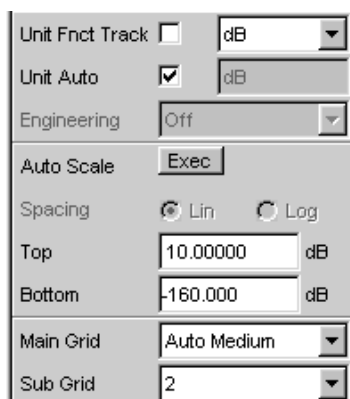

The settings for the x-axis are also mostly correct for this example; they were explained in the previous example.

- g) In the "Analyzer Function" panel, you can also use the "Show" button to open the graphical window for Post FFT. However, this displays the window in the same screen, without opening the associated configuration panel.



Introduction to Instrument Operation Using Examples

- h) The spectral display of the output signal with its harmonics may now look like the example shown below.

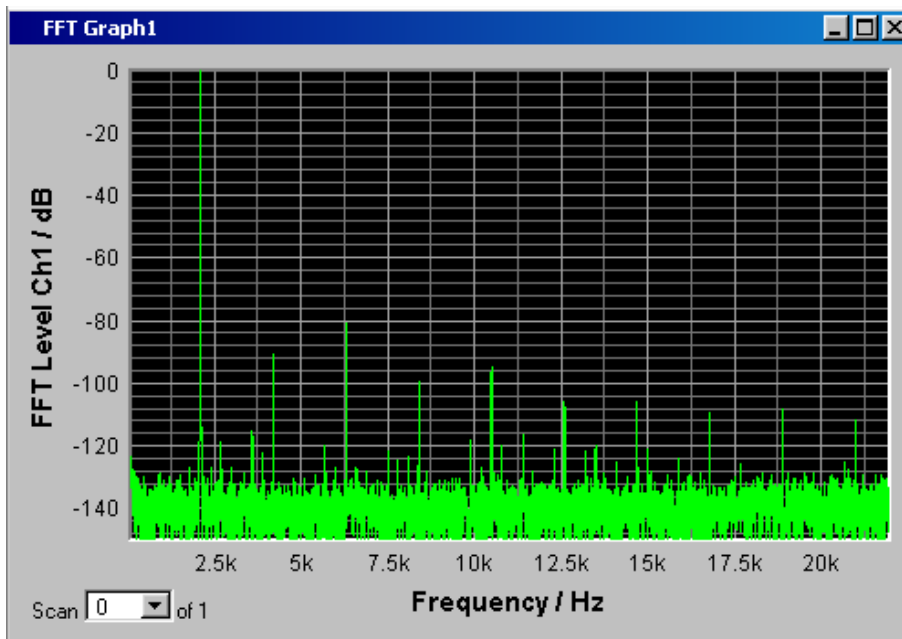

6. Step: Evaluating the graphic with cursors and markers

All graphical displays can be evaluated using horizontal and vertical cursors; the X and Y-values shown in the display fields associated with the cursors are always current values. Markers are used to identify important measurement points. The cursors and markers can only be operated using the softkey bar; the required softkeys are displayed at the bottom of the screen as soon as the graphical window has the focus.

The softkeys are arranged in several levels; the lower levels are accessed by actuating the respective button. Actuating the "Back" button redisplay the higher level.



Introduction to Instrument Operation Using Examples

a) Setting markers:

Pressing the "Marker" button calls up the Marker softkeys which are used in this example to first select Trace A so that markers can be set.



The next softkey level appears simultaneously:

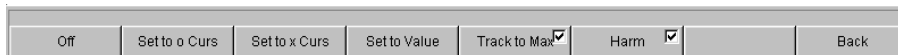

The "Track to Max" button is used to set a marker at the maximum value of the curve, i.e. the fundamental in this example of THD+N measurement.

The "Harmonics" button is used to mark the harmonics of the fundamental indicated by the marker.

Pressing the "Back" button twice calls up the first softkey level again.



Introduction to Instrument Operation Using Examples

b) Using cursors:

Activating the "Cursor" button displays the cursor softkeys:

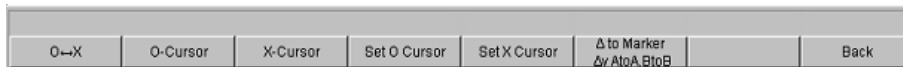

The audio analyzer uses two cursors which are identified by the symbols ○ and X. These symbols are used to mark the measured points in the graph (see the example graph below).

Only one cursor is active and can be moved in the graph at any one time. The active cursor is displayed with a solid line; the inactive cursor is displayed with a broken line.

The ○ <--> X button is used to activate the ○ and X cursor alternately. If, for example, the cursor was activated with the ○ cursor button, the following softkeys appear:

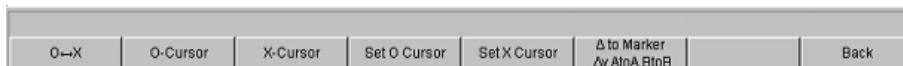

The Vert A button activates a vertical cursor on Trace A; this cursor can then be grabbed and moved with the mouse.

The step size with which the cursor is being moved can be set via additional softkeys of the next level which are called with the "Movement" softkey.

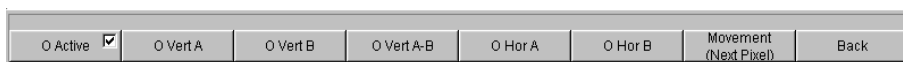

The **Movement** button opens the next softkey level where various step sizes for moving the cursor are offered. The currently selected step size is indicated in brackets in the second label field of the "Movement" button.

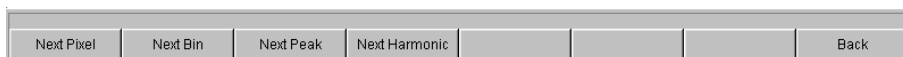

Loading Predefined Instrument Setups

- c) With activated markers and a cursor, the graphical display of the output signal with its harmonics may look like the example shown below.

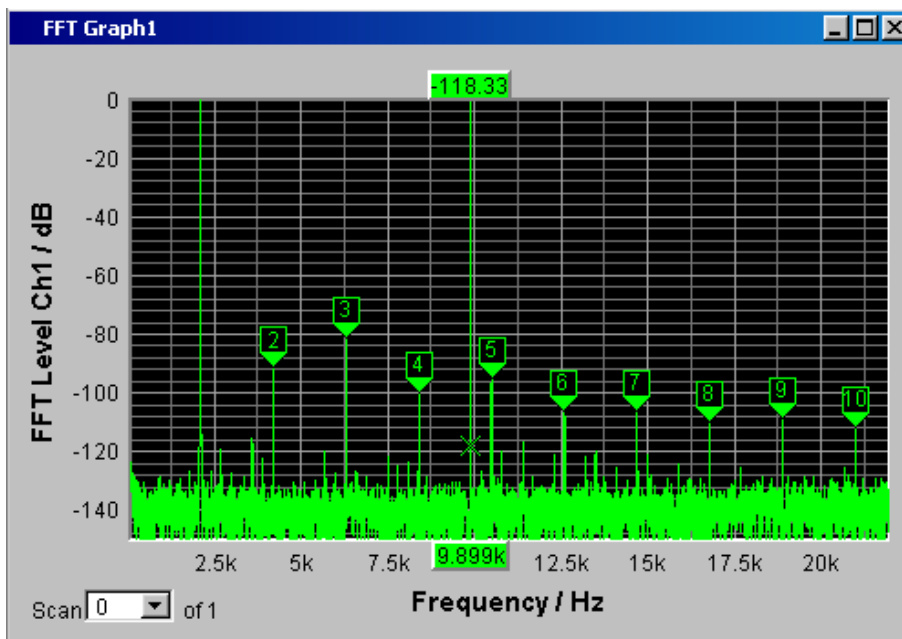

7. Step: Saving this instrument setup

This example can also be saved as an instrument setup. Saving is performed as described in the previous example.

3.5 Loading Predefined Instrument Setups

To make initial measurements easier for new users, example setups for the basic measurements required in audio engineering are supplied with every audio analyzer. These setups allow the instrument to be used almost immediately.

The setup files are available for the different domains (analog or digital) of the generator and analyzer. They are stored in the AA, AD, DA, DD subdirectories of the D:\UPV\Setup Examples directory; the generator domain is listed first followed by the analyzer domain. The file name indicates the respective application.

Many of these example measurements (essentially those at the analog interfaces) can be performed using the basic version of the audio analyzer. The R&S UPP-B2 (digital audio interfaces) option is required for all measurements at the digital interfaces.

The predefined instrument settings can be loaded in the following way:

Loading Predefined Instrument Setups

- ▶ Open the menu bar, move the mouse pointer to the "File" button and select the "Load Example Setup" entry from the opening list. The file window is opened displaying the directory in which the example measurements can be selected.

All of the setups listed here use the same basic settings.

Basic settings for analog inputs/outputs:

- All channels of the generator and analyzer are active; the unbalanced generator output signal with minimum output impedance and maximum analyzer input impedance are used.
- All inputs/outputs are floating; the auto-range function is activated.
- Frequency sweeps are usually performed logarithmically from 20 Hz to 20 kHz; the appropriate graphical windows are open on the screen; the x-axis is scaled automatically in the associated configuration panels; the y-axis is permanently set to standard values.
- Voltages are mostly given in volts; the generator output voltage is set to 0.1 V; distortion and intermodulation values are given in dB.

Basic settings for digital inputs/outputs:

- Both channels are active; the generator generates 24-bit words; the analyzer analyzes 24 audio bits. The sampling frequency is set to 48 kHz, the Professional format acc. to AES 3 is used. The digital pulse amplitude of the generator is 1 V at the BNC outputs, which corresponds to 4 V at the symmetric outputs.
- Levels are mostly given in dBFS; audio signals are usually generated at a level of -20 dBFS.

Users can, of course, adapt the used basic settings to their own specific measurement tasks at any time. To do this, the respective setup must be loaded and the appropriate changes are then made in the panels. The setup can then be saved again.

The application setups are also updated when new audio analyzer firmware is installed. Modified setups should therefore be saved under a different file name.

Users are also free to create new directories for their customized setups.

4 Manual Operation

4.1 Introduction - Manual Operation

The R&S UPP audio analyzer is available in three model variants that differ about the number of analog analyzer channels: The R&S UPP can be ordered with 8 (R&S UPP800), 4 (R&S UPP400) or 2 (R&S UPP200) channels. All models are optimized for use in production with remote control interfaces and are offered without display, without front panel controls and without CD/DVD drive. To enable a convenient manual control, the instrument can be equipped with an external monitor, an external keyboard and a mouse. All models feature the same functions.

The R&S UPP audio analyzer uses a Windows operating system. The instrument is therefore operated in largely the same way as other Windows applications. All panels and display windows have the standard Windows format and are operated in the same way. An external monitor, an external keyboard and/or mouse allow direct and convenient access to entries and settings. The clearly organized display shows the current state of the audio analyzer.

If the R&S UPP model is to be operated manually, you need to connect an external monitor, a mouse and a computer keyboard. In the "Overview of Keys" section at the end of this chapter, the keys or shortcuts on a computer keyboard and their function for the manual control are listed. For additional notes for the control via mouse and keyboard, see [Chapter 4.3.2, "Operation Using the Mouse"](#), on page 122 and [Chapter 4.3.3, "Operation Using an External Computer Keyboard"](#), on page 123.

The use of the toolbar simplifies the operation when using the mouse. See [Chapter 4.9, "Settings in the Menu Bar"](#), on page 182.

Numerous online help functions assist the user in making settings.

After being switched on, the instrument is in the same state as it was before it was switched off. This applies to all setting parameters of the R&S UPP, including the settings not currently displayed on the screen.

The following chapter describes the manual operation of the R&S UPP audio analyzer. This includes a description of the screen displays, how to operate the pan-

els and how to set parameters. Each of the setting descriptions is accompanied by a table explaining how the different functions are performed using an external computer keyboard or mouse.

An overview of the keys, panels and display windows can be found at the end of this chapter.

The functions and the remote control of the R&S UPP audio analyzer are described in detail in the operating manual which is located on the supplied documentation CD. The quick start guide features an explanation of the general operating concept and a brief introduction that contains step-by-step configurations for initial measurements (see [Chapter 3, "Getting Started"](#), on page 69).

4.2 Functional Division of the Audio Analyzer

4.2.1 Instrument Concept

The audio analyzer combines the following components in a single housing:

- Generators with analog and – with the R&S UPP-B2 (digital audio interfaces) option – also digital audio interfaces for generating the multiple test signals,
- Analyzers with analog and – with the R&S UPP-B2 – also digital audio interfaces for extensive measurement options and
- a computer (PC) with the Windows operating system for controlling and operating the entire instrument and with connections for peripherals and LAN.

4.2.2 Generators

4.2.2.1 Universal Generator

The universal generator consists of an FPGA and generates various test signals, from sine-wave tones to intermodulation test signals (two-tone signals) to noise signals and multi-tones. Following appropriate conversion, these signal are made available at the analog outputs.

Functional Division of the Audio Analyzer

With the R&S UPP-B2 (digital audio interfaces) option, they can also be output as digital data streams in various formats at AES/EBU and SPDIF interfaces and at optical interfaces.

The R&S UPP-B4 option (HDMI and digital audio interfaces) allows channel status data to be generated in the data stream of the digital audio interface of the generator instruments "Digital Audio" and "HDMI".

All test signals can be output on both channels. However, different signals are also available at the digital outputs.

4.2.2.2 Function Blocks and Their Assignment to Control Panels

The diagram below shows the function blocks of the generators in the audio analyzer:

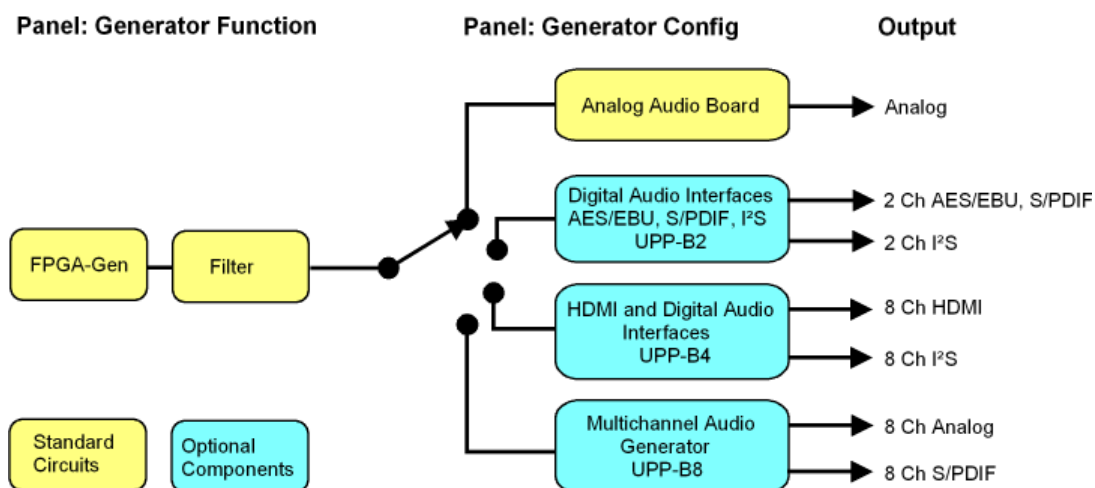

The generators of the R&S UPP are operated in two stages:

1. In the first step, the following settings are made in the "Generator Config" panel:
 - the audio interfaces at which the test signals are to be output
 - the channels which are to be active
 - maximum level and reference values
 - etc.

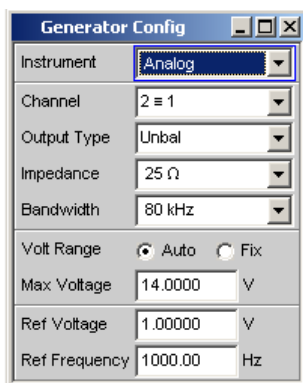

2. In the second step, the following settings are made in the Generator Function panel:

- type of test signal
- output level
- frequencies
- etc.

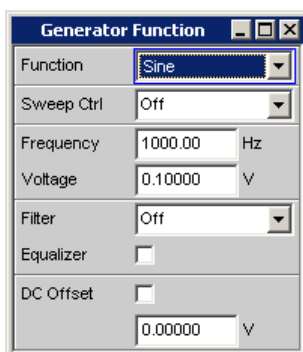

4.2.3 Analyzers

The R&S UPP performs all measurements using digital signal processing. Here, analog signals to be measured are first subjected to complex analog **preprocessing** on analog measurement modules before they are digitized and fed to the digital measurement routines.

This concept has the following advantages:

- All audio measurement functions are available at both the analog and the digital interfaces.
- The measurement methods at the analog and digital interfaces are identical.
- Operation at the analog and digital interfaces is always the same.

- The R&S UPP can also perform the complex measurement functions simultaneously on all channels; this results in an overall measuring time that is insignificantly higher than the sample time.
- Several measurement functions, e.g. level measurement, FFT analysis, waveform analysis, etc., are calculated simultaneously in FPGAs and can therefore be displayed at the same time without a delay.
- The digital measurement routines can continuously adapt their speed to the current input frequency and thus achieve high measurement speeds.
- Since the filters are also digital, an almost infinite number of filters is available and can also be used for measurements at analog interfaces.

With the R&S UPP-B2 (digital audio interfaces) option, digital audio data streams can also be measured at AES/EBU or SPDIF interfaces.

4.2.3.1 Function Blocks and Measurement Levels

The analyzer component of R&S UPP contains a series of measurement options that are organized in various measurement levels. The measurement results of these levels can also be displayed simultaneously.

The unfiltered input signal is analyzed at the **input monitor level**. The peak level at the input connectors is analyzed here.

The pre-filter, which can be looped into the signal path before all other analyses, is located in front of the **level monitor**. Here you can analyze the RMS value, the peak value or the DC voltage component of the signal to be tested.

Following any additional filtering using one or two filters, detailed analysis is initiated at the **function level**. All the usual analysis tools for measuring linear and non-linear distortion, interference, etc., can be found here. The analysis in the time domain (waveform) as well as the FFT analysis with extreme dynamic response and frequency resolution take place here. Moreover, it is possible to record input signals to the hard disk in order to analyze them at some point later.

In the **Freq/phase level**, the measured values for **frequency** and **phase** or **group delay** can be displayed in a different measurement window parallel to the structure described above.

The monitor outputs at the rear side of R&S UPP allow an oscilloscope or external circuits to be connected, can be switched to the input-monitor level or function level and allow the control of analog or digital input signals as well the different analysis levels directly at the input.

Functional Division of the Audio Analyzer

With the R&S UPP-B2 (digital audio interfaces) option, the digital ancillary data in a standard configuration, such as channel status data, validity and parity bits, can also be transmitted.

The results of these different measurement functions can be displayed in various ways in the **measurement windows**. The type of display, the units used, scaling, etc., can be set differently for each measurement function in the associated panels.

The diagram below shows the function blocks and the analysis levels of the R&S UPP:

Similar to the generator component, the analyzer component is operated in two stages:

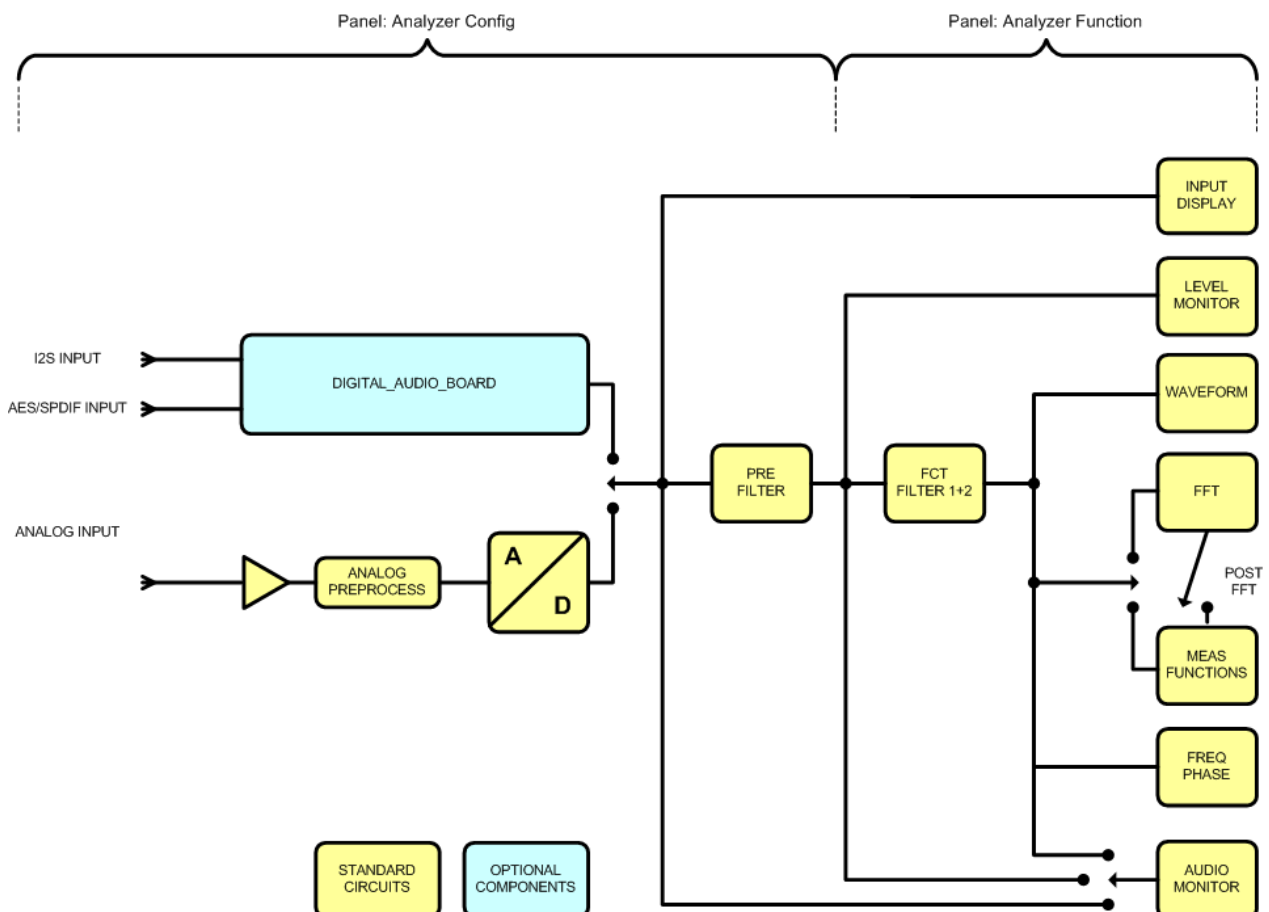

1. Operation begins in the "Analyzer Config" panel with the selection of:

- analog or digital input connectors
- number of channels
- AC or DC coupling
- IF bandwidth

- and a number of other parameters

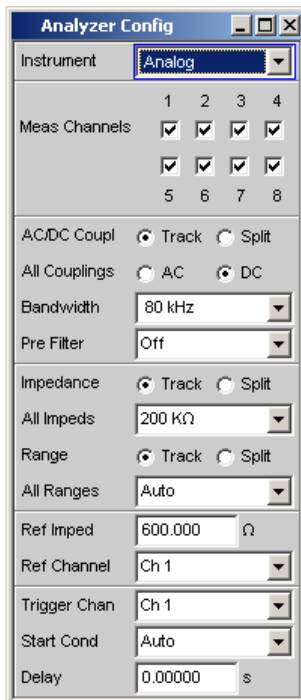

2. In the second step, the measurements are set at the various analysis levels in the "Analyzer Function" panel.

The measurements are set in the order of their importance:

- Measurements at the function level, e.g. distortion measurements (possibly with Post FFT enabled)
- Settings at the monitor level, e.g. DC measurement
- Display of the peak value at the input monitor level
- Display of frequency, phase/group delay in the freq/phase level

In addition, the waveform function can be switched on and off in this panel.

Functional Division of the Audio Analyzer

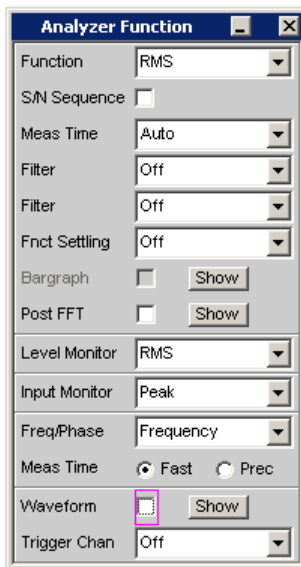

3. If the monitor outputs at the rear of the instrument are to be used, these settings are made in the "Auxiliaries" panel.

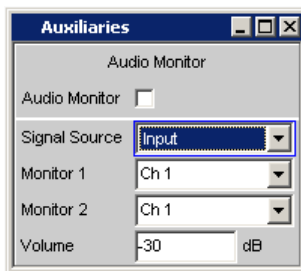

4. The following settings can be made in other panels:
 - the way in which the measurement results are to be displayed (numerically or graphically)
 - scaling
 - limit monitoring
 - minimum and/or maximum values
 - and many other parameters

4.3 General Information on Operation

4.3.1 Windows User Interface

To provide the user with a familiar environment, operation is largely based on the Windows® user interfaces. All panels, entry windows, etc., are made up of known elements, for example:

- Selection fields with parameter lists

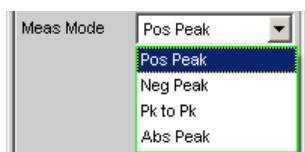

- Checkboxes



- Radio buttons



- Entry fields



A blue, green or magenta selection frame or the highlighting of an entry field (dark background) indicates the current entry focus. Entries can be made in the element with entry focus.

Operation follows the same basic rules which apply to other Windows programs in use today. It is assumed that the user is familiar with these basic rules. This information is therefore not given in detail in this manual.

4.3.2 Operation Using the Mouse

Similar to other Windows® programs, the R&S UPP can also be operated with a mouse. To permit this, a commercially available mouse (not supplied with the instrument) is connected to one of the four USB interfaces at the front or rear of the instrument (see [Chapter 2.7.2, "Connecting an External Mouse"](#), on page 34).

The mouse makes it easier to move and resize the panels and graphical windows on the screen and provides alternative control options. It allows easy operation of Windows®.

Specifically for mouse operation, the R&S UPP also features a menu bar that either can be displayed permanently at the top of the screen or appear at the top of the screen as soon as the mouse pointer is moved to the left side of the screen, and a toolbar that either can be displayed permanently at the top edge of the screen or appear at the right side of the screen as soon as the mouse pointer is moved there. In both cases, the permanent display is set in the config panel under the heading "Always visible". This toolbar contains a number of icons for calling up frequently used functions.

The functions of the mouse correspond to the following instrument functions:

Mouse	Function
Left-click	<ul style="list-style-type: none"> • Activates selection fields • Selects parameters • Activates/deactivates checkboxes • Toggles radio buttons • Quits the Edit mode
Moving the mouse pointer to left-hand edge of screen	<ul style="list-style-type: none"> • Shows the menu bar
Moving the mouse pointer to right-hand edge of screen	<ul style="list-style-type: none"> • Shows the toolbar
Turning the mouse wheel	<ul style="list-style-type: none"> • Navigation in panels, parameter lists, etc. • Changes numeric values
Pressing the mouse wheel	<ul style="list-style-type: none"> • Selects parameters • Quits the Edit mode

4.3.3 Operation Using an External Computer Keyboard

A commercially available, external computer keyboard (not part of the scope of deliveries and services) can be connected to one of the four USB interfaces at the front or rear of the instrument (see [Chapter 2.7.1, "Connecting an External Keyboard."](#), on page 34).

It simplifies the input of list entries, comment texts, file names, etc. A keyboard is required for operating Windows®.

The keys or shortcuts on the external computer keyboard correspond to the following instrument functions:

General Information on Operation

Computer key-board	Function		Computer keyboard	Function
F5 to F12	Softkeys 1 to 8		0 to 9; a to z	0 to 9; a to z
CTRL + F5	START		SPACE	Space
CTRL + F6	SINGLE		• ; * ... #	• ; * ... #
CTRL + F7	STOP CONT		+ / -	+ / -
CTRL + F8	Audio monitor on/off		SHIFT + A to Z	A to Z
CTRL + F9	Level of audio monitor		CTRL + M	MENU bar
CTRL + P	Hard copy		BACKSPACE	Undo last action
CTRL + F10	Switching Off		ESC	Exit selection without changes
CTRL + F11	Switch from remote to local		ENTER	Enter
CTRL + F12	Switch off all outputs		Cursor keys	Cursor keys
CTRL + PAGE UP	Scroll screens backward		ALT + W	Switch WINBAR on/off; Activating windows that are in the background.
CTRL + PAGE DOWN	Scroll screen forward		ALT + M	MODIFY softkey bar for size and position change of windows in predefined increments only with the help of softkey buttons. Size and position change using the keys TAB or SHIFT +TAB.
CTRL + SHIFT + TAB	Scroll WINDOW backward		ALT + H	Reduce window
CTRL + TAB	Scroll WINDOW forward		ALT + C	Close window
ALT + PAGE UP	Scroll SCAN backward		F1	Displays a help page for the currently selected parameter field
ALT + PAGE DOWN	Scroll SCAN forward		ALT + S	Opens a dialog box for saving instrument settings.

Computer key-board	Function		Computer keyboard	Function
PAGE DOWN	PAGE ▾		ALT + L	Opens a dialog box for defining instrument settings.
PAGE UP	PAGE ▲		ALT + P	PRESET function switches the instrument to default setting
TAB	Scroll down in selection lists, variation of numeric values in input fields			
SHIFT+TAB	Scroll up in selection lists, variation of numeric values in input fields			

4.4 The Display

The display is the central element for operating the audio analyzer. Both the instrument settings in the various panels and the measurement results are displayed here.

To make the various functions of the audio analyzer easier to operate, they were organized in a series of panels.

The measurement results can be displayed as digital numeric values, in data lists, in analog bar graphs, or in result graphics. The user can freely choose the number of panels and the number of graphical windows to be shown in the display. The size of the panels can be changed within wide limits, whereby the font size, scaling and so on are adapted automatically according to the type of display window.

4.4.1 The Screens

Five display windows (or "screens") are provided so that the wealth of information can be better organized.

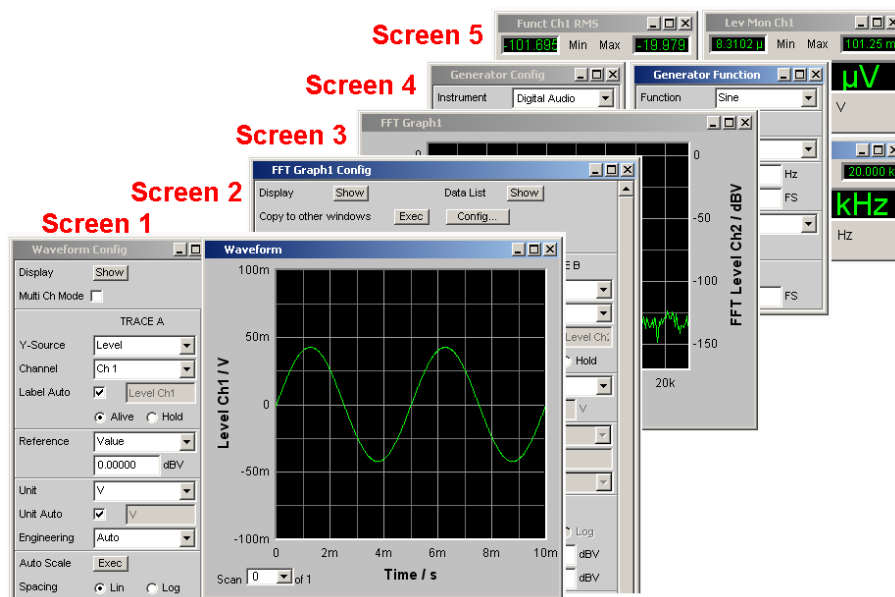
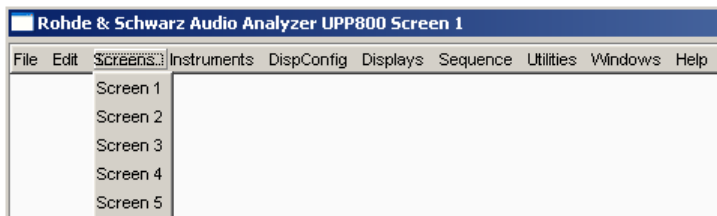

Figure 4-1: R&S UPP display with its 5 screens

The user can toggle between the individual screens in the following way:

- **Using the PC keyboard** using the shortcuts CTRL + PAGE UP or CTRL + PAGE DOWN
- First open the menu bar at the top of the display **with the mouse**, then click on the Screen button and finally select the desired screen.



- Alternatively, you can also select the desired screen directly by **clicking the appropriate number in the toolbar**.



4.4.2 Softkeys

The softkey bar which has a varying range of functions is visible in normal operating mode.

In most cases, the functions available in the selection windows of the panels are displayed in the eight buttons; these functions are displayed even if the parameter

lists have not (yet) been opened. The labeling of these buttons indicates the functions of the softkeys underneath them.

The function that has just been selected is indicated by a "pressed" button, as shown in the example below for the "RMS" function.

If there are more than eight elements to choose from, the hidden elements in the selection list can be displayed by pressing the last softkey containing the >> symbol or the first softkey containing the << symbol.

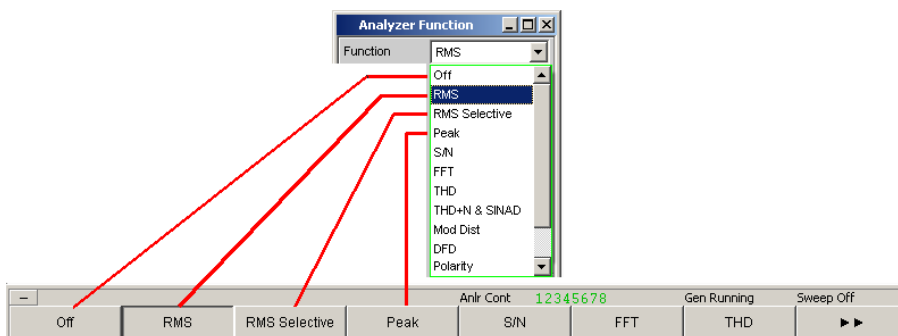

Pressing the respective softkey permits rapid selection.

Softkeys with an additional checkbox are also used for a number of applications. In the example below, the left-hand softkey F5 can be used to activate and deactivate the X cursor in a curve diagram. The other softkeys are used to make other settings affecting this cursor. The advantage of this combination is that the user can activate/deactivate a function (here the cursor) using one button and at the same time use the other softkeys for additional settings.



If an external computer keyboard is used, the softkeys can be operated using the F5 to F12 keys; if a mouse is used, the buttons in the softkey bar can be clicked directly.

Function	PC keyboard	Mouse
Select softkey function	Press keys F5 to F12.	Click button of associated softkey.

4.4.3 Moving and Resizing Panels and Graphical Windows

As soon as a panel or display window is active, it can be operated and moved on the screen using the mouse

- by grabbing the title bar and dragging it to the desired position, or
- changing its size by grabbing its edges or corners and resizing it.

4.4.4 Status Displays and Messages

In some cases, the user is presented with additional information on the screen. This information includes status messages, messages concerning the value ranges, information on settings, warnings and error messages.

4.4.4.1 Status Displays

The status of the R&S UPP is continuously displayed for the generator, analyzer, sweep system and other instrument states at the bottom of the screen above the four right-hand softkeys. Status displays always appear at the same position; they are assigned to the fields above the softkeys as shown below.

				Anlr Cont	12345678	Gen Running	Sweep Off
--	--	--	--	-----------	----------	-------------	-----------

A list of all possible status messages is available, see [Chapter 4.20, "Overview of Status Messages"](#), on page 211.

4.4.4.2 Valid Value Range

Information on the possible entries is given at the bottom of the screen above the softkey bar. The ranges for value entries specified here always take the current status of the instrument into consideration and therefore depend on the presets already configured. Below is an example for entry of the generator output voltage:

Valid Range is 0V to 14V							
V	mV	µV	dBV	dBu	dBm		

4.4.4.3 Notes

Information concerning the panel settings and so on is also given at the bottom of the screen above the softkey bar (only the space above the four left-hand softkeys is used).

*GeneratorConfig: automatic resizing			Anlr Stop	12345678	Gen Running	Sweep Off
FS	%FS	dBFS	LSBs	bits		

4.4.4.4 Warnings

If the user attempts to make measurement settings which conflict with the usual test specifications, warnings appear on the screen; these remain there until they are acknowledged with ENTER or a mouse click on OK.

Warnings are issued if no measurement results are produced during measuring mode. This is normally the result of unsuitable input signals or settings. For example, input signals may be too low to produce a stable measurement result. In this case, a warning is displayed in the middle of the screen instead of the measurement result. The warning indicates why no measurement result can be displayed and may also list several reasons for this.

4.4.4.5 Error Messages

If faults in the instrument occur during operation, an error message appears in the middle of the screen. This message remains on screen until it is acknowledged with ENTER.

4.5 Panels

In the case of the audio analyzer, associated settings and functions are always combined in "panels". Each of these panels has a name (headline in the title bar) by which it is called up.

Only one panel can have the focus, i.e. only one panel can be active at any one time. The panel with the focus can be identified by its blue title bar.

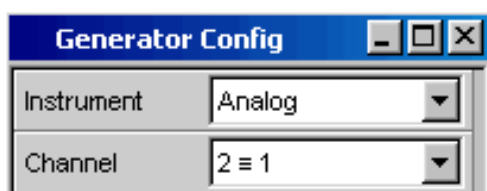

The audio analyzer distinguishes between the following panels and display windows:

- **Control panels** used to make function settings
- **Configuration panels** used for configuring how the measured values are to be displayed

- **Numeric display fields** for displaying the measured values of the various measurement functions
- **Combo displays** in which the numeric display of measured values can be supplemented by bar graphs, min/max values and limit monitoring
- **Graphical windows** in which measured values are displayed in the form of diagrams
- **Measured value lists** in which the measured values are listed in tabular form.

A detailed list of all panels together with the most important setting parameters can be found at the end of this chapter (see [Chapter 4.19, "Overview of Panels and Measurement Displays \(Graphical Windows\)"](#), on page 207).

4.5.1 Opening, Operating, Hiding and Closing Panels

Each panel and display window is a separate panel which can be either closed, opened or hidden. All displayed panels/display windows on the currently visible screen are designated as open. If the panel size is minimized and moved to the bottom edge of the screen, it is referred to as hidden.

The same panel or display window can be displayed (i.e. opened) in several screens. The display characteristics (position, size) can be different for each of the screens; the content is, however, always the same.

- **Open panel**
Panels/display windows are open if they are visible on the currently displayed screen.
A panel is opened on the currently displayed screen by activating the menu bar, moving the mouse over the "Instruments", "DispConfig" or "Displays" selection items and clicking on a panel in the pulldown menu that opens.
- **Activate panel**
Only one panel can be active on the screen at any one time.
- **Hide panel**
Open panels/display windows can be minimized and placed at the bottom of the screen. They are then referred to as hidden in the menu bar.
A panel must be activated before it can be hidden. Clicking on the left icon  in the title bar hides the panel.
- **Close panel**
Opened panels/display windows can be closed. They are then referred to as closed in the menu bar.

A panel must be activated before it can be closed. Clicking on the right icon (✕) in the title bar closes the panel.

The table below shows the operating modes for mouse and external keyboard:

Function	Computer keyboard	Mouse
Open panel	Press the shortcut CTRL+M to open the menu bar, then highlight the Instruments, Disp Config or Displays button using the TAB or SHIFT+TAB keys, open the pulldown menu using the Enter key, highlight a panel using cursor keys and select it with the Enter key.	Open the menu bar by moving to left edge of screen, press the "Instruments", "Disp Config" or "Displays" button and click the desired panel.
Activate panel	---	Click anywhere in the desired panel. With hidden panels: Press the shortcut ALT+W (WINBAR), then bring the desired panel to the foreground using the corresponding softkeys.
Hide panel	Pressing the shortcut ALT + H hides the currently active panel.	Click on the left button (⌵) in the title bar of the corresponding panel.
Close panel	Pressing the shortcut ALT+C closes the currently active panel.	Click on the right button (✕) in the title bar of the corresponding graphical window.

4.5.2 Panel Structure

This section describes the panel structure. To operate the panels on the screen, see [Chapter 4.5.1, "Opening, Operating, Hiding and Closing Panels"](#), on page 130, to set the parameters, see [Chapter 4.7.8, "Selecting a Parameter – Selection Fields"](#), on page 140. The panels have the look and feel of the Windows® interface. They differ in detail depending on their function but they consist of the same main elements.

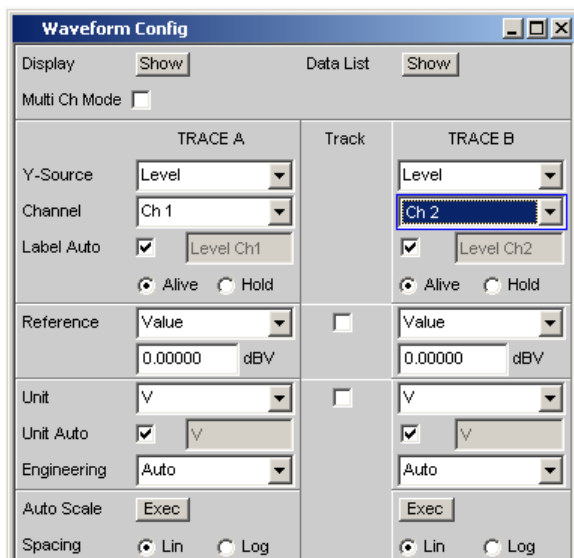



Panels consist of up to three columns, depending on the function block on which the panel is based. For example, two-channel functions are operated in panels with two columns. When defining graphical windows, settings from Trace 1 can be applied to Trace 2 in a third column between the two original columns so that trace 2 does not have to be configured separately.

Each panel contains a selection of different parameter fields which are combined in groups. Various types of parameter fields, which are operated in different ways, are used. The parameter fields have labels indicating their function.

Panels consist of the following elements:

- **Title bar**



The top field contains the name of the panel (here: "Analyzer Function") and the title bar buttons for hiding  and closing  the menu. The buttons can be operated with the mouse.

The  button maximizes graphical windows so that they cover the entire screen (see [Chapter 4.4.2, "Softkeys"](#), on page 126).

- **Headlines in panels**

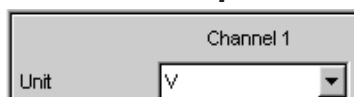

With multi-column panels, each column has a headline.

- **Function groups**

Function	Sine	▼
Dither	<input checked="" type="checkbox"/>	
	0.00010	FS
Sweep Ctrl	Off	▼
Frequency	997.000	Hz
Voltage	0.10000	FS

In panels, parameter fields which belong together with respect to their function are frequently combined in function groups. Gray lines indicate these groups.

- **Numeric entry field**

Frequency	1000.00	Hz
-----------	---------	----

A numeric value (e.g. the frequency) can be entered in this field.

- **Units**

The unit of a numeric value is displayed next to the entry field (see above).

When the value is entered, all possible units are offered on the softkey bar (on more than one level where necessary). The entry can be completed by selecting the unit using a softkey. The unit can be changed after the entry has been made. In this case, the physical value remains unchanged; however, the value displayed in the entry field is adapted automatically to the changed unit.

- **Text entry field**

Label Auto	<input type="checkbox"/>	Function Ch1
------------	--------------------------	--------------

An alphanumeric value (e.g. label text) can be entered in this field.

- **Button**

Display	Show
---------	------

Buttons are used to trigger actions; here, for example, to display a measurement graph.

- **Checkbox**

DC Offset	<input checked="" type="checkbox"/>
-----------	-------------------------------------

If a checkbox is activated, the assigned setting is selected or enabled.

- **Radio button**

Coupling	<input checked="" type="radio"/> AC	<input type="radio"/> DC
----------	-------------------------------------	--------------------------

Radio buttons are used to toggle between two settings with just a single click. Only one of the two options can be active at any one time.

- **Selection field**

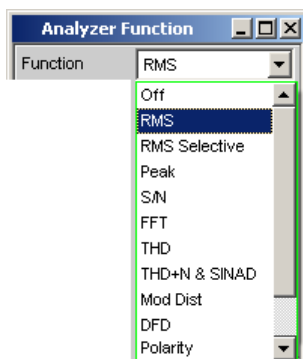

The  button indicates that a parameter list is available. The pulldown parameter list is displayed below the selection field. Depending on the number of items, the full list or only part of it is shown. Only one item at a time can be selected from the parameter list.

- **Display Fields**



Some settings can only be made in a specific configuration. If the setting is not permitted with the specific configuration selected, the respective item is disabled and displayed in gray and the field cannot be accessed. In this case, the field acts as a display field, i.e. the value displayed there corresponds to the value actually set.

- **Track box**

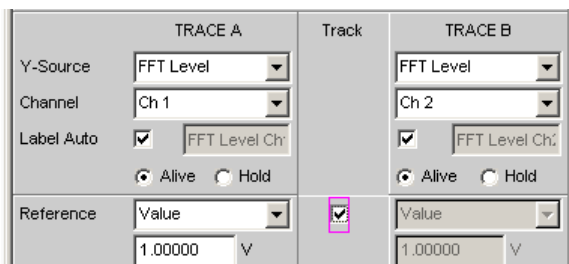

With multi-column panels, settings can be transferred from the left-hand to the right-hand column without the parameter having to be entered a second time. If the track box is activated, all of the settings within the function group apply to both columns. All fields with transferred settings are shown as display fields and cannot be accessed while the track function is active.

- **Hidden parameter fields**

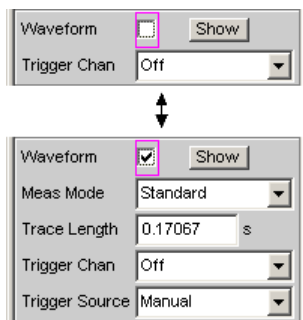

In general, an effort has been made to keep the panels as short as possible. For this reason, unneeded fields are hidden. The above example shows this: The fields "Meas Mode", "Trace Length" and "Trigger Source" appear only if the Waveform function is activated.

4.5.3 Navigating in the Panels

If a panel has more fields than can be displayed on the screen or if the size of the panel has been fixed such that its full length cannot be displayed, a scrollbar appears along the right-hand side of the panel. The length of the scrollbar symbolizes the overall length of the panel; the dark part of the scrollbar indicates which section of the panel is currently visible.

The mouse can also be used to move inside the panels in the same way as other Windows® applications, i.e. by directly clicking the desired parameter fields or by moving the scrollbar.

4.6 Settings on the Audio Analyzer

The parameters of R&S UPP are set with an external keyboard and a mouse (see [Chapter 4.3, "General Information on Operation"](#), on page 122).

Most of the parameters are set in the panels. The panels are operated on the screen as described in the section Opening, Operating, Hiding and Closing Panels. How to enter and select setting parameters in the panels is described in the following sections, the detailed description of all setting parameters is located in the operating manual supplied on the documentation CD.

Entries for file management tasks, such as saving and loading instrument settings, saving files, and so on, are made in special panels, see [Chapter 4.15, "File Management"](#), on page 195.

A number of settings are made via the menu bar. This includes all settings that configured the R&S UPP as a complete instrument, e.g. the setting of the IEC bus address, function of the HCopy key, etc. For more detailed information, see [Chapter 4.9, "Settings in the Menu Bar"](#), on page 182.

The R&S UPP is equipped with a Windows operating system. Settings at system level are only rarely required, e.g. installation of a new printer driver. Connecting a keyboard and mouse makes Windows easier to use.

4.7 Settings in the Panels

In the panels of the R&S UPP audio analyzer, associated settings and functions are combined. Each function block has its own panel.

4.7.1 Focus

Panels can only be operated if they have the focus (indicated by the blue title bar).

Before settings can be made in a panel, the relevant parameter field must be highlighted, i.e. it must have the focus. This is indicated by a selection frame which is blue, green or magenta depending on the entry mode.

The colors of the selection frame have the following meaning:

- A blue selection frame indicates a highlighted field.



- A green selection frame highlights fields in which parameters can be selected or in which an entry can be made without the selection / entry having an immediate effect on the hardware of the R&S UPP.

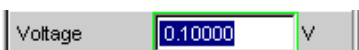

- A magenta selection frame indicates that selecting a button, activating a checkbox or changing a numeric value will be immediately passed on to the hardware and executed.

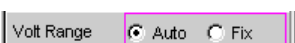

When the instrument is switched on, the most recently saved instrument settings are loaded automatically so that the instrument is in the same state as it was before power-off. The focus is placed on the first position of the active panel.

Panels are opened using the menu bar (see [Chapter 4.5.1, "Opening, Operating, Hiding and Closing Panels"](#), on page 130). How to move the focus has already been described earlier, see [Chapter 4.5.3, "Navigating in the Panels"](#), on page 135.

4.7.2 Changing the Instrument

Depending on the installed options, the audio analyzer can be used at analog and digital interfaces. Each of these interfaces determines the basic characteristics of the instrument, whereby these characteristics are separate for generator and analyzer. These interface characteristics define quasi-independent instruments within the R&S UPP. The settings for these instruments are made in the selection field in the first field of the "Generator Config" and "Analyzer Config" panel.



Each of these instruments has its own data set. If a different instrument is selected, this data set is saved. As a result, the previous settings are available when the original instrument is selected again.

The data set is structured differently for each instrument. The data sets differ with regard to the following points:

- **Selection of parameter fields / parameters:**
Example: In the case of analog instruments, all settings for configuring the analog interfaces are available (e.g. coupling); all settings for the other instruments, e.g. the digital sampling rate and so on, do not appear in the panel but remain in the background.
- **Valid value range of parameters**
The frequency ranges in the different instruments may be different.
- **Units used**
Levels are output in different units in analog and digital applications.

The examples given above show that the choice of instrument not only affects the "Generator Config" and "Analyzer Config" panel, but also has an effect on the other panels.

4.7.3 Changing Functions

The principles that apply to changing an instrument also apply to changing functions (e.g. from an RMS measurement to a THD measurement or from generating a sine-wave to multi-tone signal):

Each measurement function and generator function has its own data set. If a different function is selected, this data set is saved. As a result, the previous settings are available again when a different function is selected.

The data set is structured differently for each function. The data sets differ with regard to the following points:

- **Selection of parameter fields / parameters:**
Example: With the RMS measurement, various measurement times are offered; which is not the case for the FFT analysis.
- **Valid value range of parameters**
Example: Other frequencies can be set for intermodulation test signals than for sine-wave signals.
- **Units used**
Example: THD measurements and level measurements are specified in different units.

The following generally applies: All the settings for the other functions, e.g. filter settings and so on, remain in the background with the function settings and are displayed in the panel and set in the instrument again the next time this function is called up.

4.7.4 Hiding Parameter Fields

The R&S UPP always attempts to keep the panels as short as possible. For this reason, unneeded fields are hidden.

The following example demonstrates this more clearly: As soon as "Auto Sweep" is selected in the "Sweep Ctrl" menu item in the "Generator Function" panel, all of the fields required for configuring the sweep are displayed in the panel (together with the parameters set for the sweep last performed). If the sweep is deactivated, all of the sweep parameter fields are hidden. The user is presented with a shorter panel and is not burdened with parameter fields which are currently not needed.

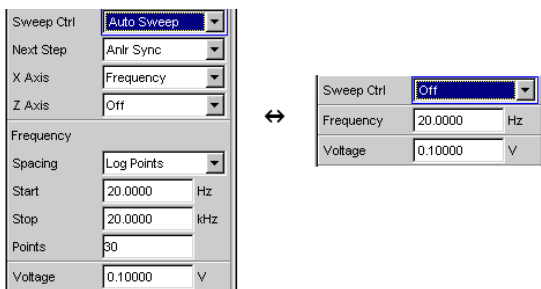

The sequence of the individual parameter fields in the panel is such that changes to parameters usually only cause changes in the fields below. Therefore, we recommend beginning at the top of the panel and working down.

4.7.5 Highlighting Controls

A control element is always selected in the same way, regardless of whether it is a checkbox, radio button, entry field and so on.

A control element is activated by shifting the focus to this element. The entry focus is indicated by a blue, green or magenta border.

The entry focus is moved with the mouse.



4.7.6 Activating/Deactivating Functions – Checkboxes

A checkbox is always used for functions which can be activated and deactivated only. If the checkbox is activated, the assigned setting is selected or enabled.

To activate or deactivate a function, click on the corresponding element using the mouse. Clicking repeatedly acts as a toggle function.



Function	Computer keyboard	Mouse
Activate/deactivate	Highlight the desired element with cursor keys, Switch the function with the Enter key.	Click checkbox.

4.7.7 Toggling Functions – Radio Buttons

Radio buttons are used for functions which can be toggled between two settings. A black dot in the appropriate button indicates the selected status.



Only one of the two options can be active at any one time.

To toggle a function, click on the corresponding radio button using the mouse.

Function	Computer keyboard	Mouse
Toggle	Highlight the desired element with the cursor keys, Toggle the function with the Enter key.	Click the desired radio button.

4.7.8 Selecting a Parameter – Selection Fields

Activating the adjacent button displays a selection field. As soon as a parameter field has the focus, a list for selecting the available parameters can be opened with the [ENTER] key or by opening a list for selecting provided parameters with a click of the mouse. The fold-down parameter list is displayed below the selection field.

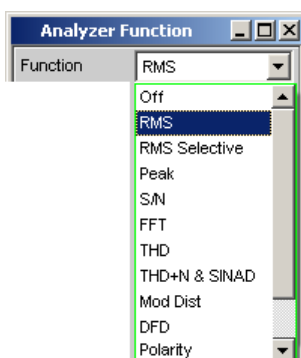

When using a mouse, items can be selected and activated by clicking on them. Only one entry can be selected at any given time.

The parameter list can be exited without adopting the highlighted parameter by pressing the ESC key.

If the list is longer than the displayed window, a scrollbar is available.



Note 1:

The contents of the parameter lists are not fixed but vary depending on other settings selected.

Note 2:

Alternatively, parameters can also be selected using the softkeys.

Function	Computer keyboard	Mouse
Open parameter list	Press the Enter key.	Click button.
Scroll	Move the displayed section of the list using the up/down cursor keys.	Activate the UP or DOWN button in the scrollbar until the desired entry is displayed.
Select parameter	Highlight the selection using the up/down cursor keys and press the Enter key.	Click parameter.
Exit the parameter list without adopting a setting	Press the ESC key.	Click anywhere outside parameter list.

4.7.9 Numeric Entries – Numeric Entry Fields

Numeric values (e.g. the output voltage) can be entered or edited in these fields.

This can be done in various ways. However, the following applies irrespective of the chosen method:

Entries outside the possible value range are not accepted; an audible warning is issued and the entry is changed to its permissible minimum or maximum value. The possible value range is displayed above the softkey bar.

4.7.9.1 Value Inputs in Edit mode – Green Selection Frame

When the focus is moved to a numeric entry field, the system enters Edit mode, which is indicated by a green selection frame. In addition, the current numeric value is highlighted with a blue background.



If the value must be completely re-entered, simply start entering numbers using the external computer keyboard; the first keystroke automatically deletes the old value. The digit to the left of the cursor can be deleted at any time during entry using the [**<--**] key.

If only certain digits are to be changed, position the cursor accordingly using the cursor keys or digit cursor and enter the new digits (if the position of the digit cursor is changed before the first digit is entered, the old value will not be deleted). The [Add] or [Insert] key can be used to switch between insert and overwrite mode.

The numeric entry field is closed with:

- **ENTER**
The newly entered value is adopted.
- **ESC**
The old value is retained.
- **Softkeys**
The selected unit is set and adopted together with the newly entered value.
- **"m" or "k" on the external keyboard**
The number entry can also be completed with the entry of the unit. Simply entering values such as "m" to the set voltage value to mV or "k" to set a frequency value to kHz is sufficient here.

The entry is set in the hardware as soon as the numeric entry field is closed.



Only the number keys and cursor keys are accepted; letters and special characters have no effect when numeric values are being entered.

4.7.9.2 Value Inputs in Direct mode – Magenta Selection Frame

When the focus is moved to a numeric entry field, the system enters Edit mode, which is indicated by a green selection frame.

Pressing the [ENTER] key switches to Direct mode and the selection frame changes to magenta.

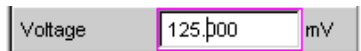

The digit cursor then moves to the first digit to the right of the decimal point or, if there is no decimal point, to the digit at the extreme right.

A digit can now be entered using the keyboard; the digit at the cursor position is replaced. The cursor does not change its position.

The digit cursor can be placed at a different position at any time using the cursor keys. Digits are then entered at the new position.

Entries in Direct mode always use the overwrite mode.

In Direct mode, every setting change is immediately passed on to the hardware and executed. For this reason, this method is particularly suited for adjustment work.

Direct mode can be exited with [ENTER], [ESC] or by clicking in a different field with the mouse.



Only number keys and cursor keys are accepted; letters and special characters have no effect.

Changes made to values are not accepted if the entries are outside the possible value range; an audible warning is issued and the entry is changed to its permissible minimum or maximum value. The possible value range is displayed above the softkey bar.

4.7.9.3 Entering/Changing the Unit of a Value

The unit of a numeric value is displayed next to the entry field. When the value is entered, all units available for the respective function are offered on the softkey bar (on more than one level where necessary). The entry can be completed by selecting the unit using a softkey.

This is done differently depending on the selected mode:

- **In Edit mode**, the newly entered numeric value is adopted and set together with the selected unit.
- **In Direct mode**, the physical value (number with the previously selected unit) is converted to the newly selected unit and adopted as the new numeric value.

After finishing entering a value or even if no value has been changed, the soft-keys can be used to change the unit in any highlighted numeric field. In this case, the physical value remains unchanged (as in the Direct mode); however, the value displayed in the entry field is adapted automatically to the changed unit. This function allows numeric values to be "converted" to other units very easily.

4.7.9.4 Information on Using Reference Values when Entering Values

The audio analyzer allows reference values in various places. These reference values are used as a basis for settings for other parameters.

The example below explains these interdependencies:

A reference voltage ("Ref Voltage") can be set in the "Generator Config" panel. The actual output voltage is set in the "Generator Function" panel where the unit is dBr, i.e. it is possible to enter the output voltage in dB relative to this reference value.

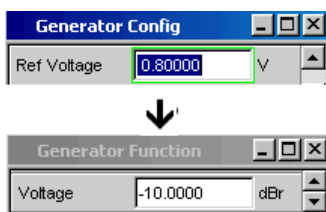

This method is particularly useful if, e.g. with an A/D converter, the clipping level has been determined and other measurements (frequency response, THD+N, etc.) have to be performed using test signals which are a certain dB value (defined in the test specifications) below this full-scale level.

It should be noted, however, that the maximum values of the R&S UPP cannot be exceeded, both for system reasons and due to the "Max Voltage" setting.

If the maximum output voltage is exceeded by increasing the reference value, the reference-based value in the "Voltage" field of the "Generator Function" panel is automatically reduced. In the following example, the maximum output voltage of 20 V forms the limit. The setting of the reference value to 100 V leads to a reduction of the value in the lower window.

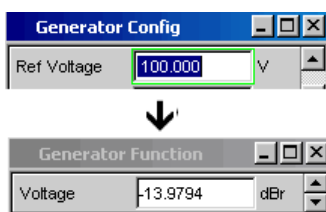

Settings in the Panels

Function	Computer keyboard	Mouse
Entering a new value: (Edit mode)	Highlight the numeric entry field and enter the new value directly using the number keys.	---
Changing individual numbers (Edit mode)	Highlight the numeric entry field, position the digit cursor with the > or < cursor keys and enter the new digit directly using the numeric keys.	---
Finishing value entry	Complete entry with the ENTER key.	---
Finishing value entry with unit selection	Use the F5 to F12 keys to select the desired unit or Complete the entry with the keys m, k, etc. to enter the value, e.g. as mV or kHz.	Click the softkey button with the desired unit.
Exit value entry without adopting the value	Press the ESC key.	Click in a different entry field.
Changing a value (Direct mode)	Highlight the numeric entry field, switch to Direct mode with the Enter key, position the digit cursor with the > or < cursor keys and enter the new digit directly using the numeric keys. All changes are set directly in the hardware.	---
Varying a value (Direct mode)	Highlight the numeric entry field, switch to Direct mode with the Enter key; position the digit cursor with the > or < cursor keys. Change the numeric value with the UP/DOWN cursor keys. All changes are set directly in the hardware.	---
Changing units	Highlight the numeric entry field, select the unit using the F5 to F12 keys. The physical value is converted to the new numeric value with the newly selected unit.	Highlight the numeric entry field, click the appropriate softkey button to select the unit. The physical value is converted to the new numeric value with the newly selected unit.

4.7.10 Alphanumeric Entries – Text Entry Fields

When the focus is moved to a text entry field, the system enters Edit mode, which is indicated by a green selection frame.



The first key stroke automatically deletes the old text. Enter characters as usual.

If certain characters only are to be changed, position the cursor accordingly using the cursor keys and enter the new characters (if the position of the cursor is changed before the first character is entered, the old text will not be deleted). The default setting is insert mode. It is only possible to change between insert and overwrite mode if an external computer keyboard is used.

The text entry field is closed with:

- ENTER – The newly entered text is adopted
- ESC – The old text is retained.

Whenever files stored on the R&S UPP are to be called up, e.g. to load saved scans in a diagram, or special functions are to be adopted from files, etc., a text entry field also appears. Here, the file name can be typed or the **...** button can be activated to call up the file directory where the desired file can then be selected. For details, see [Chapter 4.15, "File Management"](#), on page 195.



Function	Computer keyboard	Mouse
Entering new text	Highlight the text entry field and enter the new text directly using the keyboard.	---
Changing individual characters	Highlight the text entry field, position the cursor with the cursor keys and enter the new character directly using the keyboard.	---
Finishing character entry	Complete entry with the ENTER key.	---
Exiting text entry without adopting the entered characters	Press the ESC key.	Click in a different entry field.

4.7.11 Display Fields

Sometimes it is very useful for operators to receive additional information about their settings. For example, the selected FFT parameter directly affects the frequency resolution in the displayed spectrum. Display fields inside the panels are used in such cases. These fields are shown in gray and cannot be accessed. They always contain valid values and therefore always show settings active in the background; the fields are updated as soon as a setting in the associated parameter field is changed.



Depending on the settings selected beforehand, it may in some cases no longer be possible to operate certain elements – the entry field then becomes a display field and is shown in gray as described above.

Example: If measurement results are displayed in V, linear or logarithmic divisions can optionally be selected for the bar graph. For measurement results in logarithmic units, only a linear subdivided bar graph is meaningful; for this reason, the input field cannot be changed and, by default, is displayed with the "Lin" setting.

Display fields are also used when adopting parameters using track boxes.

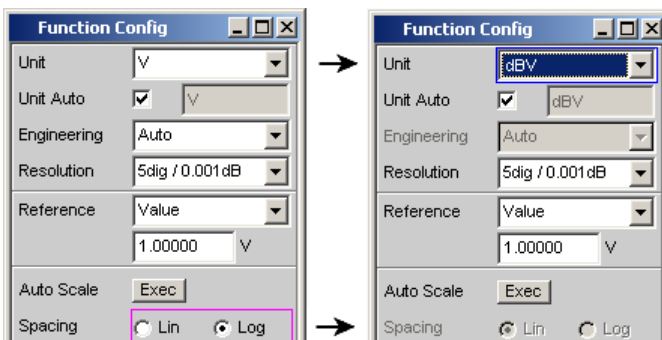

4.7.12 Adopting Parameters – Track Box

In many cases, settings are to apply e.g. to both measurement channels or to both traces. Here the R&S UPP provides multi-column panels which allow settings to be transferred from the left-hand to the right-hand column without the parameter having to be entered a second time.

The track boxes, which are displayed in a separate column, are used for this purpose. Track boxes always apply to an entire function group.

TRACE A		Track	TRACE B	
Y-Source	FFT Level		FFT Level	
Channel	Ch 1		Ch 2	
Label Auto	<input checked="" type="checkbox"/> FFT Level Ch1	<input checked="" type="checkbox"/>	<input checked="" type="checkbox"/> FFT Level Ch2	
	<input checked="" type="radio"/> Alive <input type="radio"/> Hold		<input checked="" type="radio"/> Alive <input type="radio"/> Hold	
Reference	Value	<input checked="" type="checkbox"/>	Value	
	1.00000 V		1.00000 V	

If the track box is activated, all of the settings within the function group apply to both columns. All fields with transferred settings in the right-hand column are shown as display fields. They appear gray and cannot be accessed while the track function is active. If a setting is changed in the associated parameter field in the left-hand column, this change is also shown in the display field in the right-hand column.

4.7.13 Input Help

Information on the possible entries is given at the bottom of the screen above the softkey bar. The units offered in the softkey bar and the limits specified in the "Valid Range" field always refer to the highlighted parameter field. The valid value range is given in the unit currently selected.

Entries outside the specified value range are not accepted; an audible warning is issued and the entry is changed to its permissible minimum or maximum value.



The specified ranges for value entries always take the current status of the instrument into consideration. They are therefore not constant and depend on the presets already configured for other parameters.

Below is an example for entering the generator output voltage: Additional units can be selected with the >> button:

Valid Range is -240dBV to 20dBV							
V	mV	μV	dBV	dBu	dBm	dBr	>>

4.7.14 Completing Settings

For the entry of numeric values, the R&S UPP distinguishes between Edit mode (identified by a green selection frame) and Direct mode (identified by a magenta selection frame). See also the section [Chapter 4.7.9, "Numeric Entries – Numeric Entry Fields"](#), on page 141.

- Numeric entries in **Edit mode** are adopted and set in the hardware only by using [ENTER] or selecting a unit via the softkey bar.
- In **Direct mode**, numeric values entered or changed using the mouse wheel are immediately passed on to the hardware and executed.

With checkboxes, functions are activated and deactivated by the hardware as soon as the status of the checkbox is toggled with the ENTER function. For operation using a mouse, functions are activated/deactivated as soon as the checkbox is clicked.

With radio buttons, settings are executed by the hardware as soon as the radio button is toggled with the ENTER function. For operation using a mouse, functions are toggled as soon as the corresponding radio button is clicked.

A parameter from a selection field is also executed by activating the ENTER function. In this case, a simple mouse click will select and activate the desired parameter.

Most settings are made without any noticeable adjustment or calculation times. If a brief calculation time is necessary (e.g. to calculate a multi-tone signal adapted to the FFT analysis), the calculation is performed in the background while ongoing measurements continue.

Function	Computer keyboard	Mouse
Finishing numeric value entry (Edit mode)	Complete entry with the ENTER key or Use the F5 to F12 keys to select the desired unit or Complete the entry with the m, k, etc. keys to enter the value, e.g. as mV or kHz.	Click the softkey button with the desired unit.
Immediately setting numeric value changes in the hardware (Direct mode)	Highlight the numeric entry field, switch to Direct mode with the Enter key, position the digit cursor with the > or < cursor keys and enter the new digit directly using the numeric keys.	---
Varying numeric values with immediate adoption by hardware (Direct mode)	Highlight the numeric entry field, switch to Direct mode with the Enter key; position the digit cursor with the > or < cursor keys. Change the numeric value with the UP/ DOWN cursor keys.	---

Function	Computer keyboard	Mouse
Activating/deactivating a function	Highlight the desired element with the cursor keys, Switch the function with the Enter key.	Click the checkbox.
Toggling a function	Highlight the desired element with the cursor keys, Toggle the function with the Enter key.	Click the desired radio button.
Selecting a parameter from a list	Highlight the selection using the up/down cursor keys and press the Enter key.	Click on the parameter.

4.7.15 Entries during Measurement or Data Output

All entries can be made at any time.

- **Single measurements, spectral displays:**

If the entry affects parameters of the ongoing measurement, the ongoing measurement or output is terminated as soon as the entry is confirmed (the newly selected parameters are set and the measurement or output is restarted).

- **Sweep activated:**

Since changes to parameters during a sweep can influence the measurement and thus have a negative effect on the reliability of the results displayed in the screen graphics, the current sweep is stopped and then restarted for entries of this kind.

- **Entries which do not affect the measurement process:**

Entries which do not affect the ongoing measurement process (e.g. changing a unit) are adopted immediately without the ongoing measurement being interrupted.

4.8 Measurement Displays

The audio analyzer offers various types of measurement windows for displaying the results of the numerous measurement functions. The measurement results can be displayed as digital numeric values, in analog bar graphs, in result graphics or in data lists. The user can open any number of measurement windows on the screen. The size of the panels can be changed within broad limits, whereby

the font size, scaling and so on are adapted automatically; see also [Chapter 4.4.3, "Moving and Resizing Panels and Graphical Windows"](#), on page 127.

4.8.1 Measurement Functions and Displaying Measurement Results

- **What** (which measurement function) is measured and **how** (which measurement method) measurement is performed, is preset in the "Analyzer Function" panel.
- The **configuration panels for measured value display** are used to determine how the measurement results are presented (i.e. which unit, how many digits, etc.). A series of panels for the different measurement windows are provided for this purpose.
- The results are finally displayed in the various **measurement windows**.

The basic settings in these configuration panels and measurement windows are described in the following sections. For a detailed description of the individual parameter fields, see [Chapter 4.8.2, "Numeric Display Field"](#), on page 152 and the operating manual on the documentation CD.

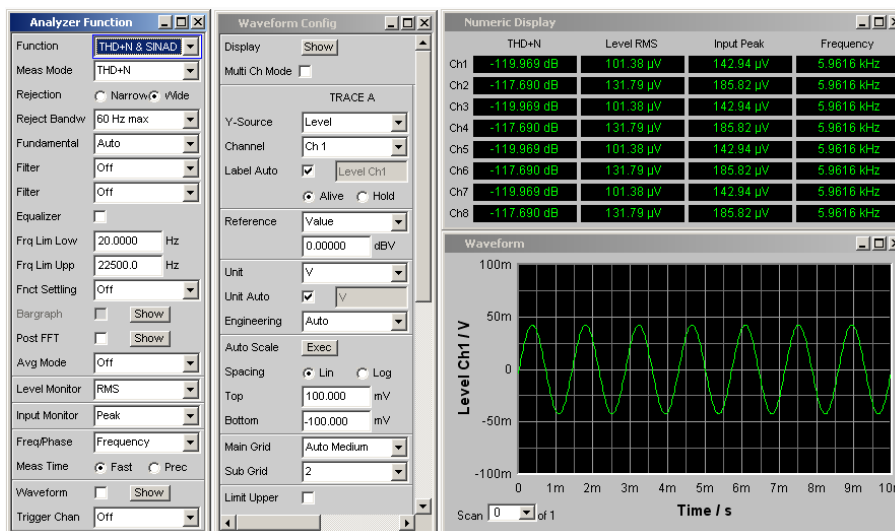

Figure 4-2: Measurements and display of results for audio analyzer

What is measured and how the measurement is performed: = Analyzer Function

Type of displays of measurement results = Waveform Config

Display of measurement results = Numeric display and measurement graph (here: waveform)

4.8.2 Numeric Display Field

The numeric display field provides a clear overview of the numeric values from various analyzer functions and displays a maximum of 32 numeric value results from the "Analyzer Function" panel. The individual columns are permanently assigned, from left to right:

- **Column 1:**
Measurement results of the function which is set in the "Analyzer Function" panel in the "Function" field.
- **Column 2:**
Measurement results for the set "Level Monitor" function.
- **Column 3:** Measurement results for the "Input Peak" function.
- **Column 4:**
Display of either the frequency measurement result or, if "Freq & Phase" or "Freq & GrpDel" is set, display of the frequency measurement result in the first row and display of the phase or group delay measurement in the second row.

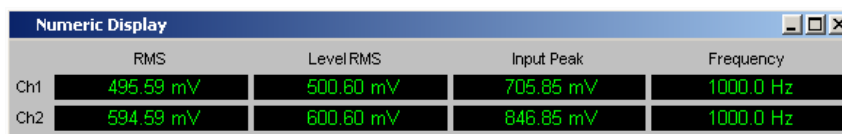

	RMS	LevelRMS	Input Peak	Frequency
Ch1	495.59 mV	500.60 mV	705.85 mV	1000.0 Hz
Ch2	594.59 mV	600.60 mV	846.85 mV	1000.0 Hz

Each column is labeled with the name of the displayed measurement function, whereby additional, more specific function-related information may also be shown in some cases. Example: For difference frequency distortion measurement, the type of measurement and the associated measurement standard, e.g. DFD d2 (IEC 268), is also displayed.

The results from the two measurement channels are shown in the measurement fields (exception: frequency/phase or frequency/group delay measurement).

If not all of the columns are required because one or more of the associated measurement functions is deactivated, the column in question is hidden.

The numeric display field is opened via the menu bar and called up using the Displays button.

Function	Computer keyboard	Mouse
Opening a numeric display field	Press the shortcut CTRL+M, then highlight the Displays button using the TAB or SHIFT+TAB keys, open the pulldown menu using the Enter key, highlight the numeric display field using cursor keys and select it using the Enter key.	Open the menu bar by moving to left edge of screen, activate the Displays button and click on the numeric display field.

4.8.2.1 Measurement Result Display in a Numeric Display Field

The display of measurement results in a numeric display field is configured in the following panels:

- Function Config
- Level Mon Config
- Input Config
- Freq / Phase Config

The following examples of measured value displays demonstrate the various display options. A number of basic settings made in these configuration panels are described in the following section. A detailed description of the display options can be found in the operating manual on the documentation CD.



If the measured value is within the preset limits or no limits were specified, the measured value is displayed in green on a black background.

A measured value for a linear unit is displayed with 3 to 7 digits; a measured value for logarithmic units can be displayed with a resolution of 0.1 dB up to 0.00001 dB.



If the measured value underruns or overruns the preset limits, it appears red on black.

As soon as the measured value is back within the limits, it changes to green again.



If a measurement channel is switched off, the text OFF appears in the corresponding measured value display.



If no measurement result is available (e.g. frequency result for DC measurement), "---" appears.

4.8.3 Combo Display

It is often the case that the numeric value of a measurement result does not contain adequate information. Additional features such as analog bar graphs, limit monitoring or the storage of maximum and minimum values are frequently required.

The combo display is used for this purpose. Additional information can be displayed for every measurement shown in the numeric display.

The free selection and free scalability mean that especially important or critical results can be monitored and tracked even when viewing the R&S UPP screen from a relatively long distance.

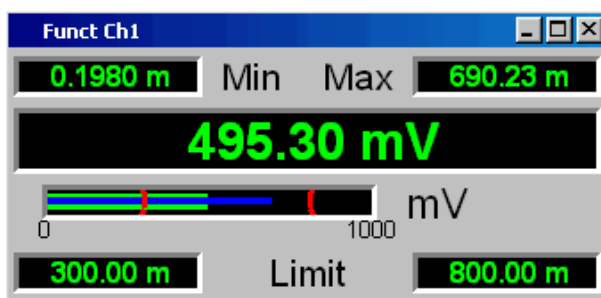

4.8.3.1 Opening Combo Displays

The easiest way to open combo displays is by double-clicking on the corresponding measured value display in the numeric display field.

The combo displays can also be opened via the menu bar: They are located under the "Displays" button underneath the "Numeric Display" option. Depending on the channel number of the selected analyzer instrument, fonts and menu structure for "Display" Function, Lev Mon, Input, Frequency and Phase measurement results change.

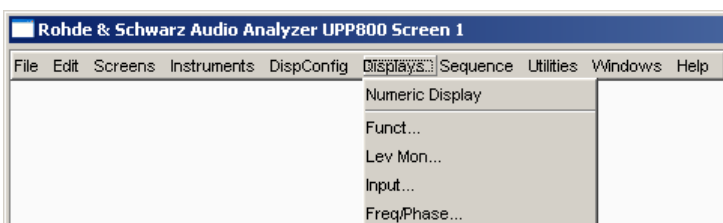

Function	PC keyboard	Mouse
Activating a Combo Display via a Numeric Display Field	Select the numeric measurement display with CTRL+TAB or CTRL+SHIFT+TAB. Highlight desired measurement display in numeric display field with TAB or SHIFT+TAB and open combo display with ENTER.	Double-click desired measurement display in numeric display field.
Activate combo display via menu bar and Config panel	Select the menu bar with CTRL+M. Select the "DispConfig" button with TAB or SHIFT+TAB. Open the pull-down menu with ENTER. Select the desired Config panel with CURSOR DOWN or CURSOR UP and open it with ENTER. In the Config panel, select the "Display Show" button with TAB or SHIFT+TAB and open the combo display with ENTER.	Click on the "DispConfig" button in the menu bar. Click on the desired Config panel. In the Config panel, click on the "Display Show" button.
Activate the combo display directly via the menu bar	Select the menu bar with CTRL+M. Select the "Display" button with TAB or SHIFT+TAB. Open the pulldown menu with ENTER. Select the desired combo display with CURSOR DOWN or CURSOR UP and open it with ENTER.	Click on the "Display" button in the menu bar, then on the desired combo display.

4.8.3.2 Settings for measurement result display in combined fields

Since a combo display is available for each measurement display of the numeric display field, up to 32 of these displays can be opened. The settings for the combo displays (and for the numeric display field itself) are made in four configuration panels, whereby up to 8 measurement channels are displayed in one panel. This results in the following four panels for configuring the measurement results in the combo displays:

- Funct Config
- Lev Mon Config
- Input Config
- Freq / Phase Config

The associated panels for configuring the combo displays are opened via the menu bar; they are called up using the "Disp Config" button.

Function	PC keyboard	Mouse
Open panel for configuring combined field or numeric display field	Press shortcut CTRL + M, then highlight Disp Config button using TAB or SHIFT + TAB keys, open the pulldown menu using the Enter key, highlight the desired panel using the cursor keys and select using the Enter key.	Move the mouse pointer to the left edge of the screen, activate the Disp Config button in the menu bar and click on the desired panel.

For the analog analyzer instrument, the Config panels are offered as a single column since the settings apply uniformly to all channels. For the other analyzer instruments, the Config panels are offered in two columns since each channel can be configured by itself.

Some of the basic settings in these panels are described here using the "Lev Mon Config" panel as an example. Since the combo display is an extension of the numeric display field, the settings also influence the numeric display field.

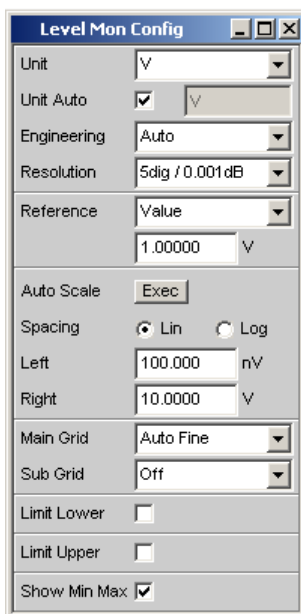

Some of the settings described below are only visible if the combined display is of adequate size on the screen. For example, scaling and grid lines are hidden automatically and stepwise if the display is reduced in size.

- **Unit of measurement result**

This parameter field is used to set the unit for the measurement result display. The units available in the parameter list depend in the type of measurement.



An overview with all the units that occur for the audio analyzer and their conversion formulas is located in [Chapter 4.17, "Units"](#), on page 199.

Details concerning the numeric value display can be specified here for all linear units.

For example, it is possible to select whether voltage is to be given in V, mV, μ V, and so on. If "Auto" is set, these unit prefixes are automatically adapted to the measured value.



- **Reference values**

The reference value for relative measured values can be set here.

This can be a fixed preset value; however, values measured at a different location or values based on the generator settings and so on can also be adopted automatically as reference values.



- **Bar graph scaling**

If the "Autoscale" button is activated, the extreme values that have so far occurred are used for scaling the left-hand and right-hand scale end value. The scaling can, however, also be set manually.

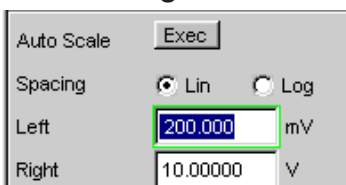

The axis can be displayed with linear or logarithmic subdivisions.

If manual scaling was selected, the start and end value of the bar graph must be entered in the two fields.

If the selected scaling does not encompass all measured values, a red arrow indicates the end of the scale at which the measured value is beyond the range of the bar graph.



- **Gridlines**

The settings Main Grid and Sub Grid are used to subdivide the bar graph.

Main Grid	Auto Medium
Sub Grid	5

Main gridlines which are labeled with the associated numeric values can be added with different intervals.

Subgridlines are used for further subdivisions; these lines are not labeled.



- Limits

A lower and/or upper limit can be defined for each measurement result.

If the limit is activated, each measured value is compared with the limit.

Limit Lower	<input checked="" type="checkbox"/>	2.34000 V
Limit Upper	<input type="checkbox"/>	

The set limits are shown in the bottom part of the combined display and appear as a red limit marking on the bar graph.

As soon as one of the limits is exceeded, the measurement display and measurement bar changes from green to red. If the measured value is within the limits, the measurement display and measurement bar are displayed in green.

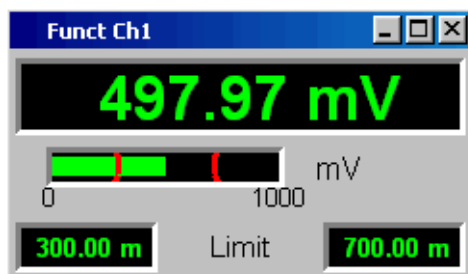

In order to monitor limit violations over a long period of time without having to watch the measurement displays continuously, the lower and/or upper limit is displayed permanently in red as soon as it is exceeded. Pressing the [START] key again or entering a new limit resets the limit to green.

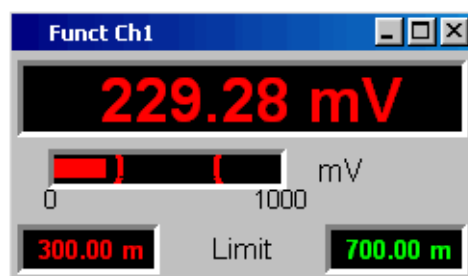

The measurement display in the numeric display field always behaves in the same way as the measurement display in the combined field; current limit violations can therefore also be monitored in the numeric display field.

- Extreme values

If this checkbox is activated, the lowest and highest measured value is displayed. Display of the Min/Max values can be set separately for each measurement display and for the two measurement channels.



The minimum and maximum values which have been measured are shown in the top part of the combined display; an additional blue bar which records the span between the extreme values is also displayed.

The Min/Max values can thus also be recorded over a long period of time without the measurement displays having to be monitored continuously.

Pressing the [START] key again resets the Min/Max values.

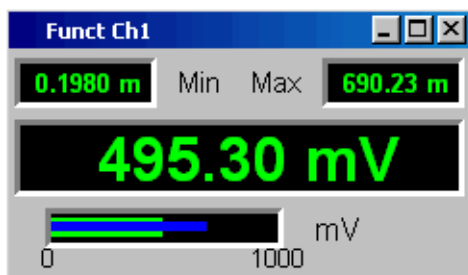

- Number of displayed digits

The "Resolution" field is used to set the number of digits used when displaying the measured values, Min/Max values and limits.



Values in linear units can be displayed with 3 to 7 digits; values in logarithmic units can be displayed with a resolution of 0.1 dB to 0.00001 dB.



4.8.4 Graphical window

The most informative method of displaying measurement results is usually a two-dimensional graphic. Measured values as a function of frequency, measurements over a time axis and so on are just a few examples of the many possible applications. The audio analyzer makes a distinction between the graphical windows

(shown in the following sections) which can be set and modified using the associated configuration panels.

All graphical displays can be evaluated using horizontal and vertical cursors; markers are used to identify important measurement points. A broad range of softkey control functions can be used to scale graphs, to display sections of graphs, and to perform many other tasks.

4.8.4.1 Sweep graph

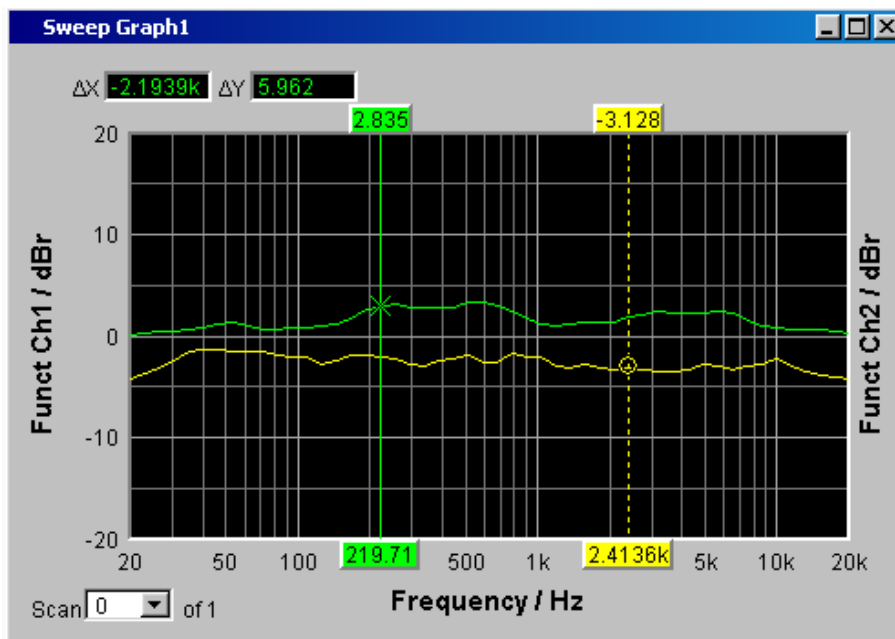

Here, the measured values of a measurement sequence (sweep) can be displayed as a line diagram in a coordinate system. One or two traces (TRACE A and TRACE B) can be recorded along an x-axis. Each trace can consist of a large number of scans. The traces can be saved and saved traces, reference curves and/or limit curves can be imported into the graph.

Up to four "sweep graphs" can be displayed at the same time and can all be configured differently. As a result, it is possible to display different measurement functions or display the same measurement function in a different way.

4.8.4.2 FFT Graph

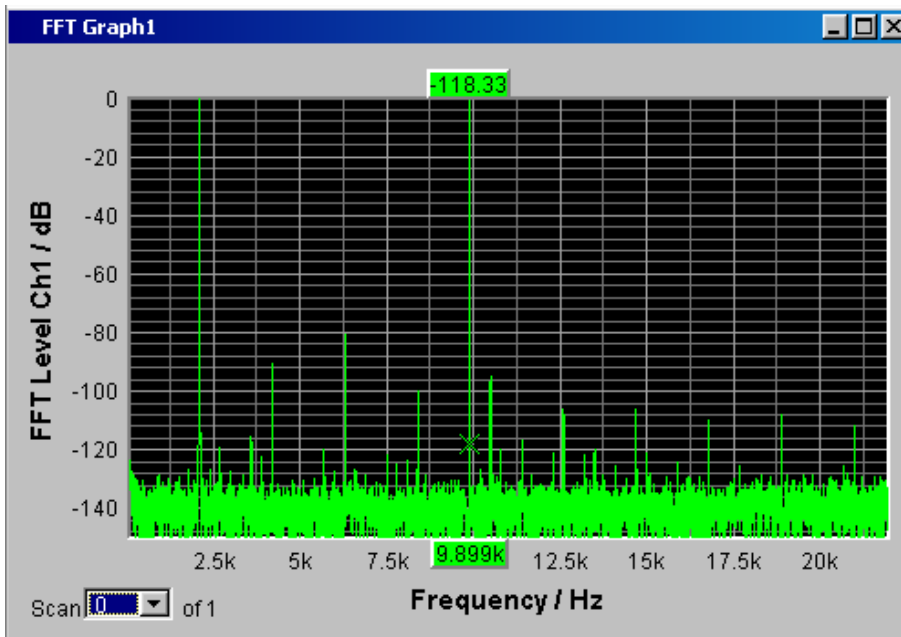

In these panels, the frequency spectrum of the **FFT** measurement function or the **Post FFT** downstream of another measurement function. One or two traces (TRACE A and TRACE B) can be recorded along a frequency axis. Each trace can consist of a large number of scans. The traces can be saved and saved traces, reference curves and/or limit curves can be imported into the graph.

Up to two FFT graphs can be displayed at the same time and can both be configured differently.

4.8.4.3 Waveform

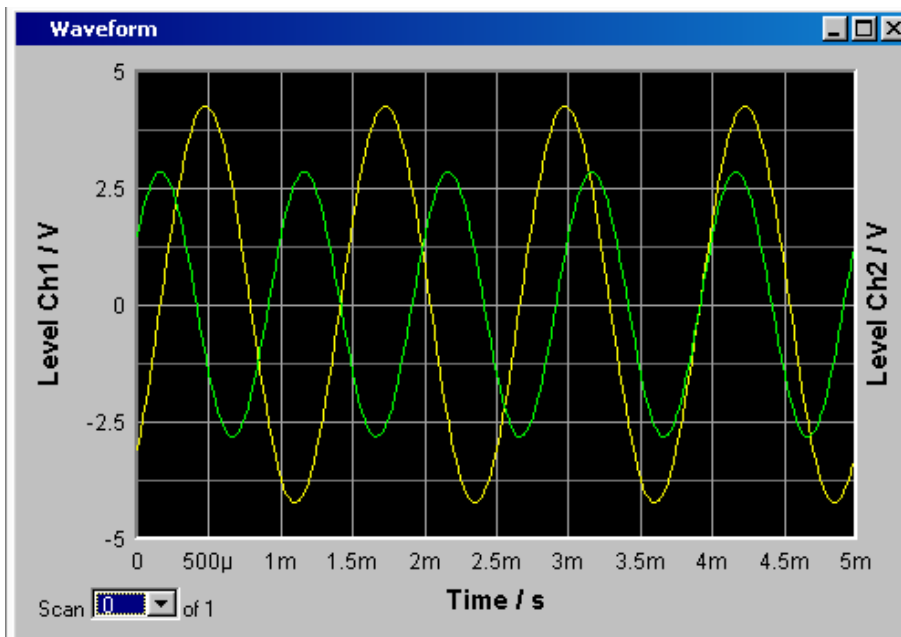

The waveform display is a type of oscillogram in which the signal characteristic of the analyzed audio signal over time is displayed. One or two traces (TRACE A and TRACE B) can be recorded along a time axis. The traces can be saved and saved traces, reference curves and/or limit curves can be imported into the graph.

This graph can be displayed once only; it is linked to the "Waveform" function in the "Analyzer Function" panel.

4.8.4.4 Bar Graph

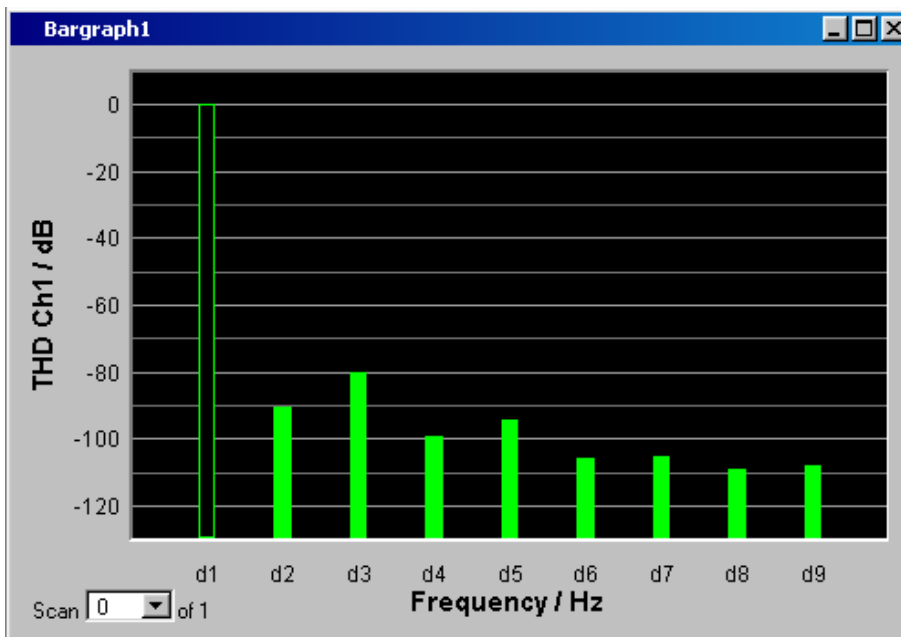

If one of the functions "THD", "Mod Dist" or "DFD" is selected in the "Analyzer Function" panel, the function measurement result can be displayed broken down into its frequency components on a bar graph. The individual distortion products are recorded along a frequency axis. The structure of the distortion products (2nd, 3rd, 4th, nth harmonic, DFD of 2nd or 3rd order, etc.) can be recognized at a glance. The bar graph can display one or two channels; once again, the results can be saved and saved results can be imported into the graph.

Two bar graphs are available so that, for example, THD values at two different measurement points can be displayed or the measured values of both input channels can be shown on two separate graphs.

4.8.4.5 Opening graphical windows

The graphical windows can be opened via the menu bar; they are called up using the "Displays" button.

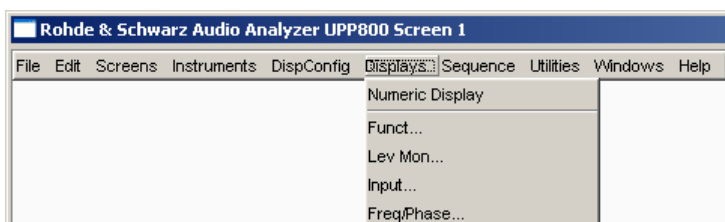

Depending on the channel number of the selected analyzer instrument, fonts and menu structure for "Display" Function, Lev Mon, Input, Frequency and Phase measurement results change.

Alternatively, the graphical windows can also be opened using the associated configuration panels (see the following section). The associated graphical window is activated using the "Show" button.

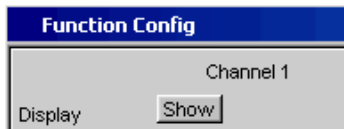

In the "Analyzer Function" panel, it is also possible to use the "Show" button to open some graphical or data windows. They will then be displayed in the same screen, without opening the associated configuration panels.



Function	PC keyboard	Mouse
Open graphical window via menu bar	Press the shortcut CTRL+M, then highlight the Displays button using the TAB or SHIFT+TAB keys, open the pulldown menu using the ENTER key, highlight the desired graphical window using the cursor keys and select it using the ENTER key.	Open the menu bar by moving to left edge of screen, activate the Displays button and click the desired graphical window.
Open graphical window via Config panel	Highlight the DISPLAY button in the associated Config panel and open the graphical window with the Enter key.	Click DISPLAY button in associated Config panel.
Open graphical window via Analyzer Function panel	Highlight SHOW button in Analyzer Function panel and open graphical window with ENTER key.	Click SHOW button in Analyzer Function panel.

4.8.4.6 Settings for measurement result display in the graphical windows

The associated panels for configuring the graphical windows are opened either using the "Disp Config" button in the menu bar or using the "Settings" softkey in the graphical window.

The settings for configuring the graphical displays are made in the following panels:

- Sweep Graph 1 to 4 Config
- FFT Graph 1 to 2 Config
- Waveform Config
- Bar Graph 1 to 2 Config

Function	PC keyboard	Mouse
Open panel for configuring a graphical window	Press shortcut CTRL + M, then highlight the Disp Config button using the TAB or SHIFT + TAB keys, open the pulldown menu using the Enter key, highlight the desired panel using the cursor keys and select using the Enter key.	Open the menu bar by moving to the left edge of the screen, activate the Disp Config button and click the desired panel.
Open panel for configuring a graphical window via softkeys in graphical window	Press F12 key for Settings softkey in respective graphical window.	Click Settings softkey in respective graphical window.

Some of the basic settings in these panels are described here using the "FFT Graph1 Config" panel as an example.

A detailed description of the display options can be found in the operating manual on the documentation CD.



Some of the settings described below are only visible if the graphical window is of adequate size on the screen. For example, scaling and grid lines are hidden automatically and stepwise if the display is reduced in size.

Settings for the y-axis

All the panels used for configuring graphical windows have three columns.

In all graphical windows, two traces (TRACE A and TRACE B) can be recorded on y-axes along an x-axis. The "Y-Source" parameter field is used to determine which measurement functions are mapped to the y-axes. For multi-channel analyzer instruments, the input channel to be mapped can be selected using the "Channel" parameter field. In the sweep graphics, every trace can also consist of several individual traces (scans).

In many cases, settings are to apply to both traces. The track boxes provide multi-column panels which allow settings to be transferred from the left-hand to the right-hand column without the parameters having to be entered a second time.

If the track box is activated, all of the settings within the function group are applicable to both columns. All fields with applied settings are shown in the right-hand column as grayed out display fields. These fields cannot be accessed while the track function is active. If a setting is changed in the associated parameter field in the left-hand column, this change is also shown in the display field in the right-hand column.

Displayed values

The data which is to be graphically displayed can be determined for each trace. Usually this data comes from the selected measurement functions; however, saved data (reference data) can also be displayed.

With Label Auto, the y-axis of the graph can be labeled with the data name selected under Source (see example below), or users can define their own label.

The "Hold" radio button is used to "freeze" the graphical display.



Additional scans can be added to a graph ("Append"), or existing scans in a graph can be replaced by new ones ("Replace").

Reference values

The reference value for relative measured values can be set here. This can be a fixed preset value; however, values measured at a different location or entire scans from files, from the other measurement channel and so on can also be used automatically as reference values / reference curves.

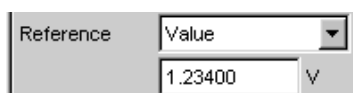

Units of Measured Values

This parameter field is used to set the unit for the trace. The units available in the parameter list depend in the type of measurement.

Alternatively, if the checkbox is selected, the unit used in the analyzer will be used.

An overview with all the units that occur for the audio analyzer and their conversion formulas is located in [Chapter 4.17, "Units"](#), on page 199.



Details concerning the numeric value display can be specified here for all linear units.

For example, it is possible to select whether voltage is to be given in V, mV, μ V, etc. If "Auto" is set, these unit prefixes are automatically adapted to the measured value.



The used unit will appear on the y-axis of the graph (see example below). Sometimes it is better to use a label defined by the user; this label can be entered in the parameter field.



Y-axis scaling

If the button for automatic scaling is selected, the audio analyzer uses the minimum and maximum values of the available measurement cycle to automatically determine a suitable value range for the graph to be displayed. This scaling is determined once and retained until the autoscale function is triggered again.

If manual scaling is required, the upper and lower end value of the y-axis must be entered in the two fields.

If a linear unit has been selected for the y-axis, this axis can be displayed with linear or logarithmic subdivisions.

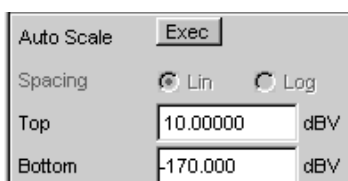

Gridlines

The settings Main Grid and Sub Grid are used to subdivide the bar graph.

Main Grid	Auto Medium
Sub Grid	5

Main gridlines which are labeled with the associated numeric values can be added with different intervals.

Subgridlines are used for further subdivisions; these lines are not labeled.

Limits

A lower and/or upper limit can be defined for each measurement result.

If the limit is activated, each measured value is compared with the limit.

Lim upper	<input checked="" type="checkbox"/>
Source	Value
	-65.0000 dBV
Lim lower	<input type="checkbox"/>

Limit curves appear as a red line on the graph.

Each measured value which violates a limit is highlighted by a red dot on the curve. In addition, a red arrow pointing up/down in the bottom right-hand corner of the graph provides a permanent indication of limit overranging/underranging.

Every restart of a continuous measurement with [START] resets the limit monitoring again. Resetting the limit monitoring can also be done with the "Restart Min/Max, Lim Violation" softkey.

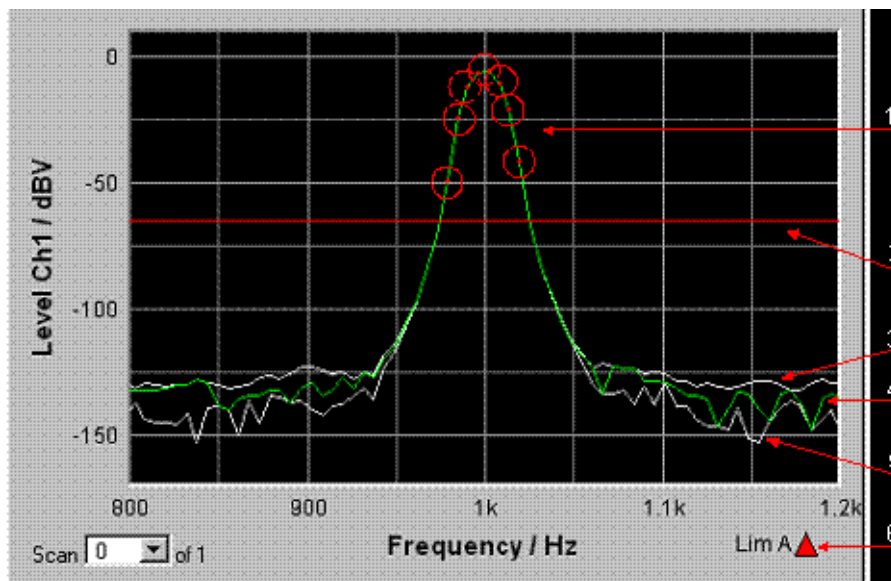

- 1 = Limit overshooting (here also marked with circles)
- 2 = Limit line
- 3 = Max value trace
- 4 = Trace
- 5 = Min value trace
- 6 = Limit display

Extreme values

If this checkbox is activated, a Min and Max characteristic is displayed that indicates the lowest and highest measurement results of a measuring sequence.



Two additional gray lines which represent the measured extreme values (see the example above) then appear in the graph.

The Min/Max values can thus also be recorded over a long period of time without the measurement displays having to be monitored continuously.

Every restart of a continuous measurement with [START] resets the limit monitoring again. Resetting the limit monitoring can also be done with the "Restart Min/Max, Lim Violation" softkey.

Settings for the x-axis

The same rules that apply to the y-axis also apply to the settings of the x-axis.

Display of X and Y Values

The "Resolution" field is used to set how many digits are used when displaying values on the x-axis and y-axis and at the cursor.



Values in linear units can be displayed with 3 to 7 digits; values in logarithmic units can be displayed with a resolution of 0.1 dB to 0.00001 dB.

Loading and saving traces / scans



The current trace together with all scans can be saved in these parameter fields by calling up the file directory using the ... button; for details, see [Chapter 4.15, "File Management"](#), on page 195.

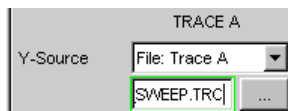

Here, saved traces together with all of their scans can be loaded and displayed in the current graph by calling up the file directory using the ... button.

4.8.4.7 Evaluating Graphical Displays with Cursors and Markers

All graphical displays can be evaluated using horizontal and vertical cursors; the X and Y-values shown in the display fields associated with the cursors are always current values.

Markers are used to identify important measurement points.

The cursors and markers can only be operated using the softkey bar; the softkeys can be operated from the front panel, using the keys F5 to F12 on the external PC keyboard or by clicking with the mouse.

The graphics can be scaled or displayed zoomed in sections via softkeys or by using the mouse.

The basic settings in these functions are described here using examples.

A detailed description of the display options can be found in the operating manual on the documentation CD.

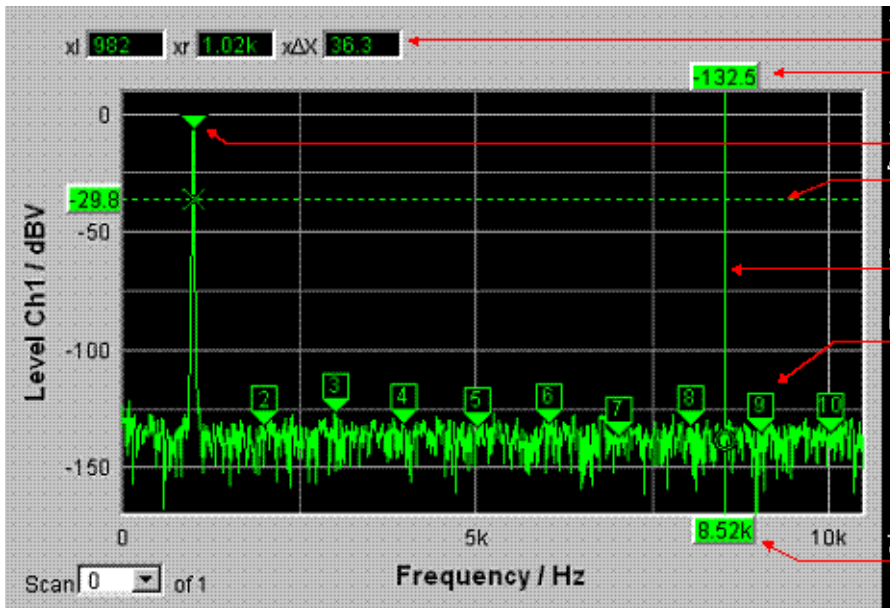

- 1 = Additional cursor values
- 2 = Cursor Y value
- 3 = Marker
- 4 = Horizontal cursor
- 5 = Vertical cursor
- 6 = Harmonic marker
- 7 = Cursor X-value

As soon as the graphical window has the focus, the softkey bar for operating the graphical elements is shown at the bottom of the screen.

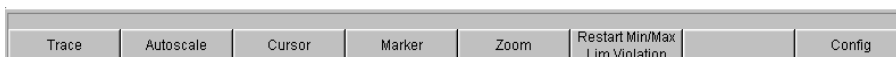

The softkeys are arranged in several levels; the lower levels are accessed by activating the respective button. Activating the "Back" button redisplay the higher level. At the lowest respective level, the buttons directly trigger the desired function.

Showing and hiding traces – Trace function

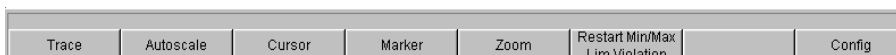

Activating the "Trace" button opens another softkey level.



Scaling graph – Autoscale function



Activating the "Autoscale" button opens another softkey level.



The softkeys available here are used to rescale the selected axes (if required, it is also possible to rescale the axes for certain traces only). The action triggered with these buttons corresponds to that of the "Auto Scale" or "Scaling Auto" button for the y or x-axis in the associated configuration panels. The "All" button scales x and y-axis simultaneously.

Operating the cursors

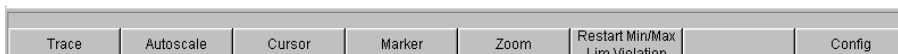

Activating the "Cursor" button displays the cursor softkeys:

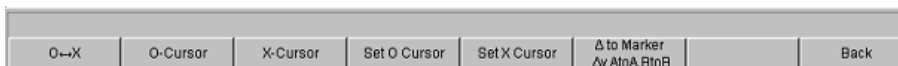

The audio analyzer uses two cursors which are identified by the symbols O and X. These symbols indicate the measured point in the graph (see the example graph above).

Only one cursor is active and can be moved in the graph at any one time. The active cursor is displayed with a solid line; the inactive cursor is displayed with a broken line. The "O<->X" button alternately switches the O and X cursor. Alternatively, the [ENTER] key can also be used to switch between cursors.

The two buttons "O-Cursor" or "X-Cursor" activate the respective cursor and display the next softkey level.

The two buttons "Set O-Cursor" and "Set X-Cursor" open the next softkey level where the respective cursor can be set to certain values, e.g. maximum, minimum, etc.

If, for example, the cursor was activated with the "O-Cursor" button, the following softkeys appear:

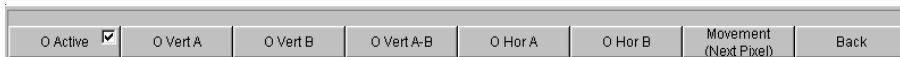

For the "O Active" button, a softkey with an additional checkbox is used. The softkey indicates that the O-cursor is active and that further settings for this cursor are available under the adjacent softkeys. Activating/deactivating the checkbox shows/hides the cursor in the graph.

The two buttons "O Vert A" or "O Vert B" activate vertical cursors and place them on TRACE A or TRACE B. Both the cursor and its label fields are displayed in the color of the associated trace.

Activating the "O Vert A-B" button displays a gray cursor which represents the difference between the values for TRACE A and TRACE B.

The two buttons "O Hor A" or "O Hor B" activate horizontal cursors and place them on TRACE A or TRACE B. Both the cursor and its label fields are displayed in the color of the associated trace.

The "Movement" button leads to the next softkey level where you define how the cursor can be moved. The second line of the label shows the currently set step size in parentheses.

Moving the Cursor

Only one cursor is active and can be moved in the graph at any one time. The active cursor is displayed with a solid line; the inactive cursor is displayed with a broken line.

The "O<->X" button alternately switches the O and X cursor. Alternatively, the [ENTER] key can also be used to switch between cursors.

In the case of operation using the mouse, the desired cursor or one of its display fields can be activated and moved by simply clicking with the mouse.

A cursor can be moved in a number of different ways:

- On the external PC keyboard, the keys TAB / CTRL + TAB move the cursor to the right / left.
- In the case of operation using the mouse, the cursor can be clicked and moved by holding down the mouse key.

The step size with which a cursor is moved can be set using softkeys. To do so, the softkey of the desired O or X-cursor must first be selected:



The "Movement" button opens the next softkey level where various step sizes for moving the cursor are offered irrespective of the graph currently being used. This is described in greater detail below. The currently selected step size is indicated in brackets in the second label line of the "Movement" button.

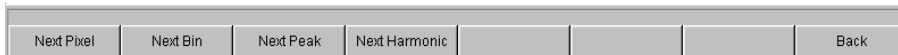

Sweep graph

- **"Next Pixel "**

Selecting the "Next Pixel" button moves the cursor by one pixel in the graphic with every increment. If there is not a measured value at every pixel in the graphical display (because only a few measurement points were recorded relative to the size of the displayed graph), the cursor value is interpolated linearly at the pixels between the measured values. If the number of recorded measurement points in the graph is greater than the number of pixels available for display, the largest measured value in each case is displayed at the corresponding pixel with X and Y value.

- **"Next Step "**

Selecting the "Next Step" button moves the cursor to the next measured value with every increment. The cursor is therefore moved in smaller or larger steps depending on the number of measurement points. If the graph is displayed relatively small or the number of recorded measured values displayed is greater than the number of pixels available in the graphical field, the cursor sometimes does not appear to move (it remains on the same pixel). However, the associated display fields always show the currently selected measurement point with X and Y-value.

- **"Next Peak "**

Selecting the "Next Peak" button moves the cursor to the next measured peak with every increment.

FFT Graph

- **"Next Pixel "**

Selecting the "Next Pixel" button moves the cursor by one pixel in the graphic with every increment.

With FFT analyses, the number of recorded measurement points (bins) is usually much greater than the number of pixels available for display in the graph; the cursor then indicates the bin with the largest measured value at the pixel in question and displays this bin with its X and Y-values.

- **"Next Bin "**

Selecting the "Next Bin" button moves the cursor to the next measured bin with every increment.

Since with FFT analyses the number of recorded measurement points (bins) is usually much greater than the number of pixels available for display, the cursor sometimes does not appear to move (it remains on the same pixel). However, the associated display fields always show the currently selected measurement point with X and Y-value.

- **"Next Peak "**

Selecting the "Next Peak" button moves the cursor to the next measured peak with every increment.

- **"Next Harmonic "**

Selecting the "Next Harmonic" button moves the cursor to the next marked harmonic with every increment.

This button is also available if the harmonic marker is not active (see the next section, Operating the markers). In this case, the button activates the harmonic marker.

Waveform

- **"Next Pixel "**

Selecting the "Next Pixel" button moves the cursor by one pixel in the graphic with every increment.

If there is not a measured value at every pixel in the graphical display (because only a few measurement points were recorded relative to the size of the displayed graph), the cursor value is interpolated linearly at the pixels between the measured values.

If the number of recorded measurement points in the graph is greater than the number of pixels available for display, the largest measured value in each case is displayed at the corresponding pixel with X and Y value.

- **"Next Sample "**

Selecting the "Next Sample" button moves the cursor to the next measured value with every increment.

If the graph is displayed relatively small or the number of recorded measured values (samples) displayed is greater than the number of pixels available in the graphical field, the cursor sometimes does not appear to move (it remains on the same pixel). However, the associated display fields always show the currently selected measurement point with X and Y-value.

Bar Graph

- **"Next Value "**

Only the "Next Value" setting is available here; the cursor moves to the next measured distortion point (harmonic or intermodulation product) with each increment. The softkey movement indicates the step size.

All of the step-size settings for cursor movement described here only affect the currently selected cursor and are only applicable in the selected graphical window. This means that when a different cursor is activated or a different graphical window is selected, the cursor is moved using the settings applicable there.

The selected step size applies equally to vertical and horizontal cursors.

Function	PC keyboard	Mouse
Moving the Cursor	Activate desired cursor via softkeys and move using keys TAB and CTRL + TAB.	Click desired cursor or associated display field and move cursor with mouse key held down.
Select active cursor via soft-key	Press the F5 function key of the "O<->X" softkey; this softkey toggles between O and X-cursor.	Click desired cursor or one of its display fields.
Select active cursor via Enter function	If desired graph has focus, Enter key toggles between both cursors.	Click desired cursor or one of its display fields.

Cursor in traces with several scans

If a trace consists of several scans, the cursors only move along one scan and indicate the x and y-values of this scan. The scan number displayed in the bottom left-hand corner of the graph in the respective display field indicates which scan is being analyzed.

Scan of 2

In order to analyze individual scans with cursors, the cursor is switched to the desired scan in the following way:

- External PC keyboard: with the keys ALT + PAGE UP and ALT + PAGE DOWN
- Mouse: by clicking the "Scan" field shown above

Operating the markers

Trace	Autoscale	Cursor	Marker	Zoom	Restart Min/Max Lim Violation	Config
-------	-----------	--------	--------	------	----------------------------------	--------

Activating the "Marker" button displays the marker softkeys:



The user must first select the trace on which a marker is to be set. The next soft-key level appears simultaneously:



The two buttons **"Set to O-Curs"** and **"Set to X-Curs"** set the marker to the value of the currently selected cursor.

- **"Set to Value "**

Sets marker to a value that can be entered later in an input field that appears in the area of the softkeys

- **"Track to Max"**

sets a marker at the maximum value of the curve. If the maximum value changes, the marker is set at the new maximum value.

- **"Harm "**

marks harmonics of the frequency indicated by the marker.

If no marker has been set, activating the "Harmonics" button sets the marker to the maximum value of the trace and calculates and marks the harmonics from this frequency.

- **"Off"**

button deactivates the marker and the indication of the harmonics.

Zooming the graph



Activating the "Zoom" button displays the zoom functions.

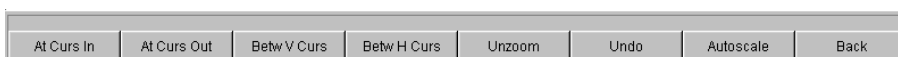

- **"Act Curs In "**

The "Act Curs In" button zooms in on the section of graph on either side of the active X-cursor.

- **"Act Curs Out "**

The "Act Curs Out" button zooms out from the section of graph on either side of the active X-cursor.

- **"Betw V Curs" or "Betw H Curs"**

The "Betw V Curs" or "Betw H Curs" button zooms in on the area between the two X or Y-cursors. The zoomed display is fitted to the size of the set graph.

- **"Unzoom "**

The "Unzoom" button restores the original axis, i.e. undoes all of the zoom operations performed.

- **"Undo "**

The "Undo" button undoes the zoom operation last performed.

- **"Autoscale "**

The "Autoscale" button displays the next softkey level. The softkeys available here are used to rescale the selected axes (if required, it is also possible to rescale the axes for certain traces only). The initiated action corresponds to that of the "Autoscale "button in the corresponding configuration panel.

Restart Min/Max, Lim Viol function

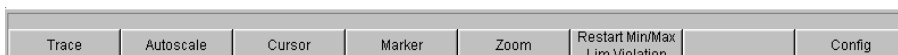

Activating the "Restart Min/Max, Lim Violation" button displays another softkey level.

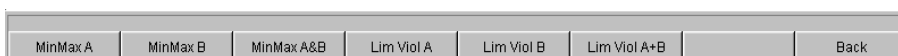

If the Show Min/Max function was selected in the associated configuration panel, activating the appropriate button in the softkey bar reactivates indication of the lowest and highest measured value.

If the Lim upper or Lim lower function was selected in the associated configuration panel, activating the appropriate button in the softkey bar reactivates limit monitoring.

Config function



The "Config" button allows the user to open or close the configuration panel while operating the associated graphical window.

4.8.4.8 Measured value Display in Lists

The measured values can also be displayed in lists instead of or in combination with the graphical windows.

Measured values which have violated the preset limits are displayed in red.

In addition, a red arrow pointing up/down in the bottom right-hand corner of the graph provides a permanent indication of limit overranging/underranging.

Restarting a continuous measurement with START and activating the "Restart Min/Max, Lim Violation" button resets the limit monitoring.

	X A (Hz)	Y A (dBV)	X B (Hz)	Y B (V)
1	0.0000	-69.095	0.0000	350.95 μ
2	93.750	-39.118	93.750	11.069 m
3	187.50	-27.028	187.50	44.525 m
4	281.25	-26.888	281.25	45.246 m
5	375.00	-32.595	375.00	23.455 m
6	468.75	-41.195	468.75	8.7142 m
7	562.50	-59.177	562.50	1.0994 m
8	656.25	-85.654	656.25	52.158 μ
9	750.00	-90.839	750.00	28.713 μ
10	843.75	-106.186	843.75	4.9060 μ
11	937.50	-103.418	937.50	6.7471 μ
12	1.0312 k	-109.352	1.0312 k	58.142 μ
13	1.1250 k	-95.781	1.1250 k	16.254 μ

Scan 0 of 1 Selection: All Lim A ▲

- 1 = Columns with measured values
- 2 = Numbering of measured values
- 3 = Measured value with limit violation
- 4 = Cursor
- 5 = Display for limit violation
- 6 = Display filter

Open data list

Data lists can be opened via the corresponding configuration panels. The associated graphical window is activated with the "Data List Show" button.

Function	PC keyboard	Mouse
Open data list	Highlight Data List button in associated Config panel and open graphical window with Enter key.	Click Data List button in associated Config panel.

Data list settings

Function	PC keyboard	Mouse
Open panel for configuring a data list	Press shortcut CTRL + M, then highlight the Disp Config button using the TAB or SHIFT + TAB keys, open the pulldown menu using the Enter key, highlight the desired panel using the cursor keys and select using the Enter key.	Open the menu bar by moving to the left edge of the screen, activate the Disp Config button and click the desired panel.

For an in-depth description with the detailed options for the settings in these panels, see the operating manual on the documentation CD.

A number of basic settings for the data lists are described here using examples.

The measured values displayed in the lists are always linked to the values in the result graphics. This means that all settings in the configuration panels, e.g. unit, engineering, set limits and so on, are also applied to the measured values in the lists.

The position of the cursor is also shown in the lists; the highlighted measurement number indicates the location of the cursor. Similarly, the step size of cursor movement set via the softkey bar (see the previous section) also affects the movement of the cursor in the data list.

Navigating in lists:

- If a mouse is used, you can either click the desired value or navigate using the scrollbar.
- As soon as a value has been highlighted in the list with the mouse (blue selection frame), the up/down cursor keys and the TAB/Shift+TAB keys allow navigating in the columns and the left/right cursor keys in the rows.

As soon as the data list has the focus, softkeys appear at the bottom of the screen.



The "Close" button closes the data list.

If the "Find Cursor" button is activated, the displayed section of the data list changes so that the value highlighted with the cursor is in the middle of the list. If both cursors are activated, this button is used to toggle between the two cursor values.

Using the "Selection" button, it is possible to filter the list of displayed measured values, i.e. to list only selected rows. If this button is activated, a further softkey level appears containing softkeys for selecting the displayed values:



Depending on the selected softkey, the following are listed in the data list:

- All
- only the values which exceed the upper, lower or both limits
- only harmonics or
- only peaks

Cursor in lists with several individual scans

If a trace consists of several scans, only the values of one scan can be displayed in the list at any one time. The scan number displayed in the bottom left-hand corner of the data list in the respective display field indicates which scan is entered in the list.

In order to list individual scans, the desired scan is selected in the following way:

- External PC keyboard: with the keys ALT + PAGE UP and ALT + PAGE DOWN
- Mouse: by clicking the "Scan" field shown above

4.9 Settings in the Menu Bar



The menu bar of the audio analyzer is used in a similar way to other Windows® applications. The following settings are made in the menu bar:

File

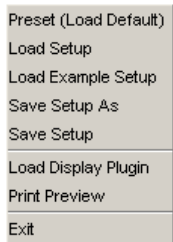

- **Preset (Load Default)**

To load instrument default settings.

A dialog box appears with the confirmation query: "Do you want to preset the device?"

- **Yes**

Preset is performed

- **No**

Cancel

- **LAN Reset**

Another confirmation query appears: "Do you really want to reset the LAN Settings? The settings will be set to DHCP + AutoIP / VXI-11 discovery on". Answering with "Yes" **resets the LXI LAN default settings**, loads the factory-preset **instrument default settings** and **restarts the instrument**.

- **Load Setup**

To load instrument settings (corresponds to [ALT+L] on the external keyboard).

- **Load Example Setup**

To load instrument settings already prepared by Rohde & Schwarz for a broad range of typical measurements and available on the instrument as example applications; these setups are divided into various application areas (AA, AD, DD, DA) depending on whether the generator or analyzer is operated with analog or digital interfaces.

- **Save Setup As**

To save instrument settings under a new name or to overwrite an existing setup (corresponds to [ALT+S] on the external keyboard).

- **Load Display Plug-in**

A plug-in can be selected here that expands the display options of UPP by additional panels, e.g. a spectrogram representation.

- **Print Preview**

A preview window of the current graphic is displayed here which is shown with the color profile configured for the respective output device. From here, the actual output can be initiated or the action can be canceled.

- **Exit**

To exit the R&S UPP measurement program.

Edit



- **Cut**

To cut characters, character strings, data, etc., and transfer them to the clipboard.

- **Copy**

To copy characters, character strings, data, etc., to the clipboard.

- **Paste**

To paste characters, character strings, data, etc., from the clipboard.

- **Select All**

To select characters, character strings, data, etc., and transfer them to the clipboard.

Screens

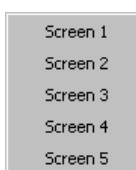

- To select one of the five display options (screens), see [Chapter 4.4, "The Display"](#), on page 125.

Instruments

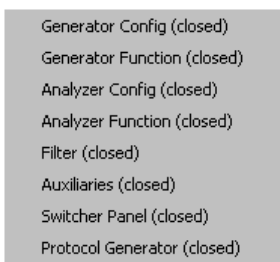

To select the panels for configuring the generators, analyzers, filters and supplementary functions.

- The desired panel must first be highlighted and is then displayed on the currently selected screen (see [Chapter 4.5.1, "Opening, Operating, Hiding and Closing Panels"](#), on page 130)
- In the list, open panels are displayed without a suffix, closed panels are identified by the suffix "closed", and open minimized panels by the suffix "hidden".

DispConfig

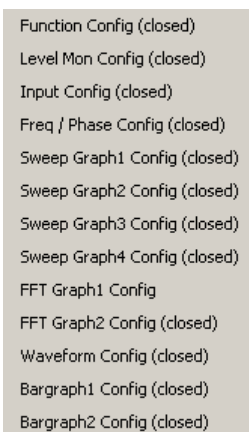

- To select the panel used to configure the measurement display windows.
- The desired panel must first be highlighted and is then displayed on the currently selected screen (see [Chapter 4.5.1, "Opening, Operating, Hiding and Closing Panels"](#), on page 130)
- In the list, open panels are displayed without a suffix, closed panels are identified by the suffix "closed", and open minimized panels by the suffix "hidden".

Displays

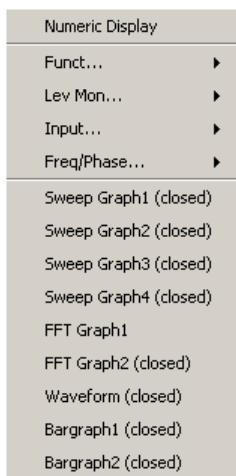

- To select the measurement display windows.
- The desired measurement window must first be highlighted and is then displayed on the currently selected screen (see [Chapter 4.5.1, "Opening, Operating, Hiding and Closing Panels"](#), on page 130)
- In the list, open panels are displayed without a suffix, closed panels are identified by the suffix "closed", and open minimized panels by the suffix "hidden".

Sequence

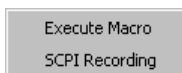

- **Execute Macro**
To select sequences (macros) used to automate previously programmed measurement procedures to start.
- **SCPI Recording**
Recording of remote control commands to simplify the creation of measurement programs.

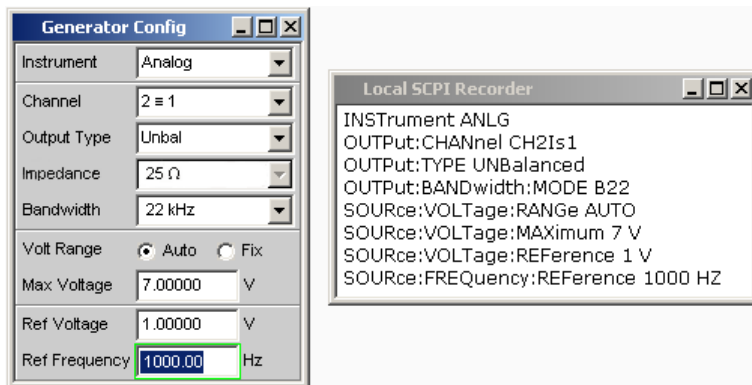

Utilities

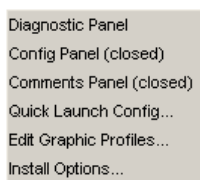

- **Diagnostic Panel**
Opens a panel for entering service settings
- **Config panel**
Opens a panel for entering instrument-wide settings, e.g. IEC bus address, the appearance of the file select box or whether the menu bar or toolbar is permanently displayed on the monitor.
- **Comments panel**
Allows entering a comment for the current setup. This comment is stored in the setup and displayed again after reloading. A few style options are available for the entry and can be selected via the right mouse button.
- **Quick Launch Config ...**
In the toolbar, you can define up to 8 icons that either load setups or execute macros when clicked with the mouse; see [Chapter 4.10, "Settings on the Toolbar"](#), on page 190.
You can determine these functions in the "Quick Launch Config..." window.

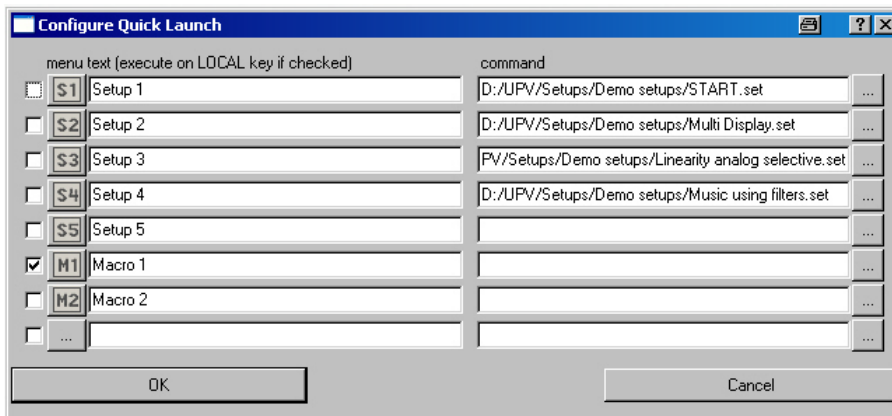

If a checkbox on the left side is activated, the corresponding setup or macro can be executed by means of the shortcut [CTRL+F11]. If several checkboxes were enabled, the entries are processed from top to bottom.

Icons can be randomly defined by the user for the adjacent button column. You can do this using the icons (S1 to S8 or M1 to M8), which are included as standard on the instrument and can be found in the `C:\UPV\Config\res` directory.

However, you can also use any other icon. The only requirements are that the icon has a size of 20 x 20 pixels and that it is available as a BMP file on the hard disk of the audio analyzer.

Clicking the  button with the mouse opens the File Selector, where you can select the icon file you want.

In the text fields, you can enter comments to describe the individual setup/macro; these comments are then displayed when the mouse is moved over the button. If there is an asterisk to the left of the comment, this means that the checkbox on the left side is active and that the setup/macro is executed using the above-mentioned keys.

In the command column, you can select the setup/macro that is to be activated with the symbol. The easiest way to do this is to click on the button with the mouse, whereupon the File Selector is opened, making it possible to select the required file.

- **Edit Graphic Profiles ...**

Opens a window in which the current graphic is displayed with additional controls for editing the selected color profile. The line colors and types as well as the background colors can be set individually.

- **Install Options ...**

Displays installed options and allows installing software options

Utilities Config panel, General Configuration settings

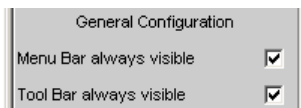

The R&S UPP allows you to have the menu bar and/or the toolbar displayed at the top edge or at the right-hand edge of the screen all the time. This feature is primarily for operation with the mouse.

- **Menu bar always visible**



- **Toolbar always visible**



Windows

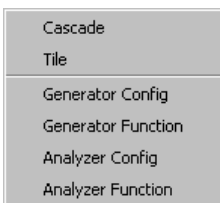

- **Cascade**

To cascade all open panels / measurement windows.

- **Tile**

To tile all open panels / windows.

- **Panel names**

To display and select all panels and measurement windows which are open and displayed on the current screen. Selecting a panel moves it to the foreground.

Help

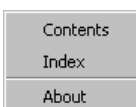

- **Contents**

Calls up the help system of the audio analyzer, see [Chapter 4.14, "Help System"](#), on page 193.

- **Index**

Call up of the help system of the audio analyzer with an alphabetically sorted listing of all terms used in the help system.

- **About**

To call up information about the firmware version installed on the instrument.

4.10 Settings on the Toolbar



Similar to other Windows® applications, the toolbar uses icons for the R&S UPP that execute functions if clicked on with the mouse. The following functions are offered:



Starts continuous measurements and sweeps.

Resets the Min/Max values for bar graph displays, averaging for measurement results, and limit overranging



Starts a single measurement or a single sweep



Measurement / sweep is stopped or continued (toggle function).



Depending on the settings under "Utilities" in the menu bar, "Config Panel" printout of the screen contents on the connected printer is started or the screen contents are stored in a file.



Switches all outputs of the measuring instrument off or on again (toggle function).



Opens a panel for loading predefined instrument settings



Opens a panel for storing instrument settings



Selects the appropriate display window (screen), where the colors used have the following meaning:

- The currently selected visible display window is indicated in green.
- All screens in which windows are activated are indicated in yellow.
- Blank display windows are indicated in gray.



Symbols for conveniently loading predefined instrument settings or starting macros using the mouse. For the settings for this purpose, see [Chapter 4.9, "Settings in the Menu Bar"](#), on page 182.



Starts the "R&S UPX Sequencing" software. This is a program that the allows the user to run test sequences.

4.11 Settings in the Operating System

The R&S UPP is equipped with the Windows operating system. Settings at system level are only rarely required, e.g. installation of a new printer driver.

Connecting a keyboard and mouse makes Windows easier to use.

4.12 Auxiliaries Panel

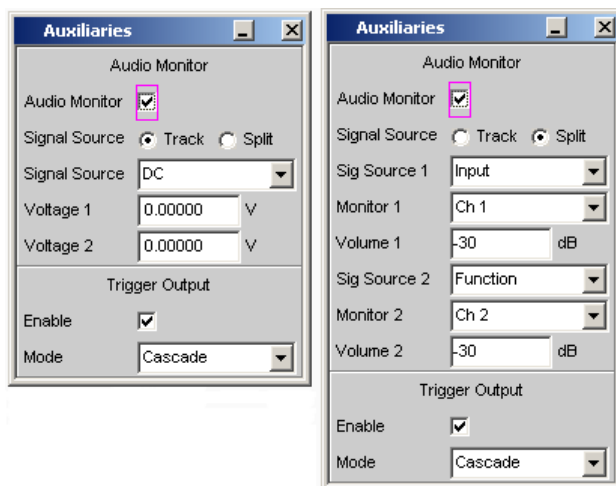

In the "Auxiliaries" panel, the "Audio Monitor" add-on function can be selected for setting the monitor function for viewing analyzer signals and settings for the trigger output.

It is divided into the following sections:

- **Audio Monitor**, for configuring the audio-monitoring functions
- **Trigger Output**, for configuring the trigger output at the rear of the instrument

4.12.1 Audio Monitor Function

The monitor outputs (BNC sockets on the rear panel) permit the monitoring of analog or digital input signals (referred to as "Monitoring" in this document), both directly at the Audio Analyzer input and downstream of any filters that may be active. They also permit DC voltage output for supplying power to DUTs or external circuits.

The required settings are made in the Auxiliaries panel; the settings described here are intended as examples.

A detailed description of the display options can be found in the operating manual on the documentation CD.

"Audio Monitor" switches the monitoring function on or off.

In the "Signal Source" Track / Split row, the "Signal Source" and output voltage at the monitor outputs ("Volume") can be selected for both monitor outputs together ("Track") or separately from each other ("Split").

The "Signal Source" field is used to select which signal is to be monitored. This can be the measurement signal switched to the analysis path either in the "Input" or "Function" level, i.e. with or without corresponding filtering. The individual levels of the analyzer are explained in greater detail in the section "Function blocks and measurement levels". Starting with serial numbers 120100, 140100, 180100, two DC voltages independent of each other in the range from -5 V to +5 V can be output.

The fields "Monitor 1" and "Monitor 2" are used to select which BNC socket is assigned to which measurement channel.

In the "Volume" field, the level at the BNC sockets is set by entering or changing the numeric value in the range from -120 dB to 120 dB.

The "Voltage" line sets the DC level at the BNC jacks.

Alternatively, CTRL+F9 of the external keyboard can be used to set the level at the BNC sockets. A window with a symbolized volume control opens which can be operated directly with the cursor keys or the mouse.

4.12.2 Trigger output

A trigger output for the following application is on the rear panel:

- **Gen Sync:** Output for a signal dependent on the start of the generator that can be used to trigger external instruments / circuits.
- **Cascade:** Reserved for later applications.

4.13 Rapid Deactivation of Outputs

CTRL+F12 of the external keyboard can be used in case of malfunctions to switch off the outputs of the generator.

The switched-off lines can be reactivated only by pressing CTRL+F12 again.

The switch-off of generator outputs is indicated by the **GEN OVLD** LED:

- **LED is yellow:** The generator outputs were switched off due to malfunctions or with CTRL+F12 of the external keyboard.
- **LED is red:** The generator outputs were overloaded by an external signal feed \geq of approx. 12 V peak and switched off **at high impedance**.

4.14 Help System

The R&S UPP has a context-sensitive help system. The help system provides a help page for every parameter and can be called up at any time while the instrument is being operated. The help system has a navigation bar, i.e. starting from the context-sensitive page it is possible to move to other help pages using the contents list, the index, scroll arrows and page-internal links.

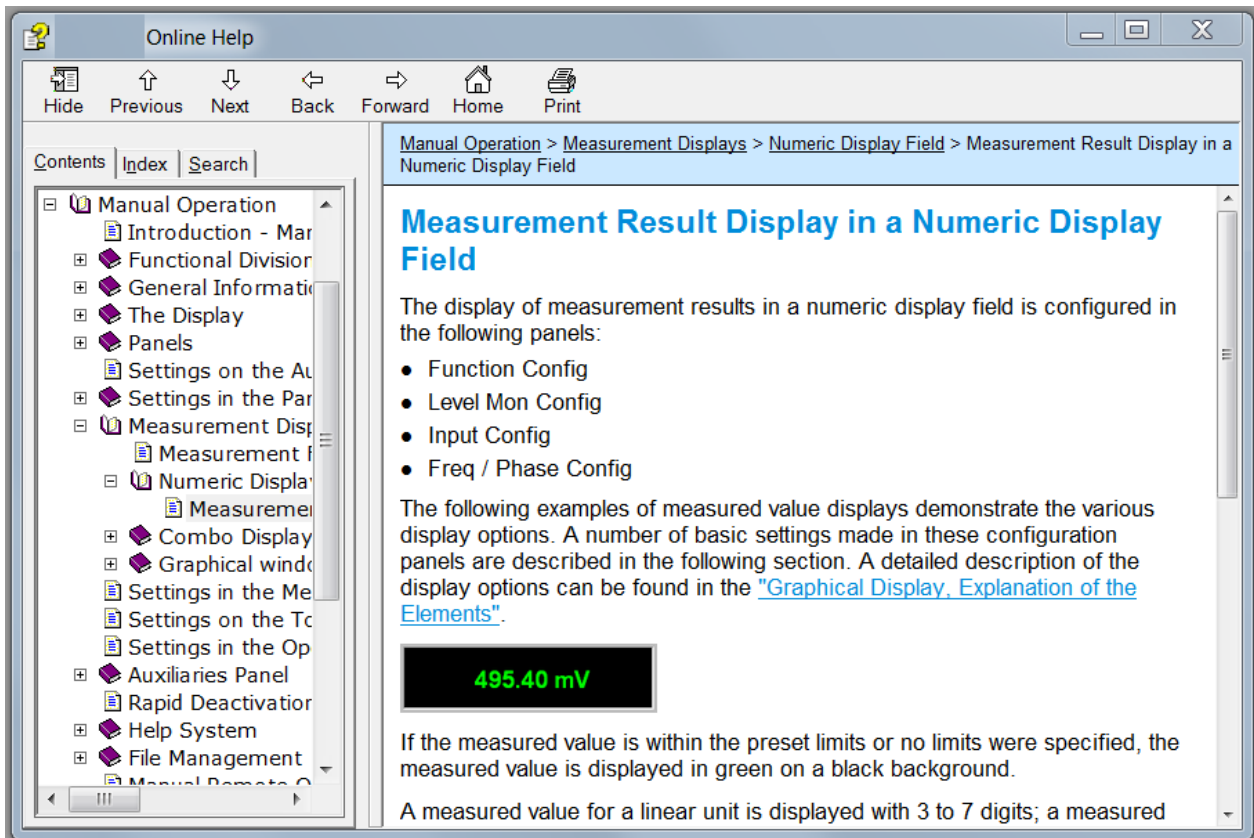

The Help window is divided into three areas. On the left-hand side is a column that displays either the entire help contents list or the index. To the right of that is a large area showing the current help page. A mouse is required for operation.

Function	PC keyboard	Mouse
Open help for a highlighted parameter field	Press F1 key	---
Help page for selected parameter is displayed		
Close help	Press ALT + F4 keys	Close Help window

4.15 File Management

The R&S UPP uses files to store all instrument data, i.e. system and user data. User data includes stored instrument settings, data for equalizer files, lists for sweeps, and so on.

The files are stored on the instrument's hard disk. The `D:\` drive is available for storing user-defined data and can have any number of directory structures. A number of default directories are preconfigured; they can, however, be changed at any time.

Files can be transferred either using a USB stick or via a connected network.

In the case of a connected network, all network drives that can be accessed are available (see [Chapter 2.10.2.4, "Accessing directories in the network"](#), on page 45).

The files are distinguished by their extension; each file type has a certain content. Normally, the extension is of no importance to the user since the files are accessed in the associated panels where only the relevant file type is available. For example, the files with equalizer settings can only be loaded in the "Generator Function" and "Analyzer Function" panels if the appropriate function settings have been made.

To load settings or to store results, the "File Select" window must be called up in the associated panel using the **•••** button.

4.15.1 Loading and Saving Instrument Settings

With the menu bar and the button "File", "Load Setup", "Load Example Setup", "Save Setup as", "Save Setup" or "Load Display Plug-in", the "File Select" window is called up.

Every R&S UPP audio analyzer has a range of instrument settings which have been prepared by Rohde & Schwarz for a broad selection of typical measurements and which are available on the instrument as sample setups. These setups are divided into different application areas (AA, AD, DD, DA), depending on whether generator or analyzer is operated with analog or digital interfaces, and are selected via the menu bar, "File" and "Load Example Setup".

This allows users to make settings for their own specific measurement tasks very simply by modifying these example setups.

All of these sample settings are located in the directory D:\UPV\Setup Examples. Every R&S UPP also features the factory-based default instrument setting which can be called up directly via the menu bar, "File", "Preset (Load Default)".

4.15.2 List of File Extensions Used

File type	File extension	Meaning
Instrument settings	.SET	Setup file for saving and loading the instrument parameters set by the user ("complete" setup)
	.SAC	Setup file for saving and loading the instrument parameters set by the user ("current" setup)
Equalizer setting	.FTF	Amplitude/frequency table for noise generation in the frequency range
	.VEQ	Equalizer file; loaded in the "Equal File" parameter field of the Generator Function and Analyzer Function panels
Equalizer setting	.SWL	Sweep list for the following: Dwell times for automatic generator sweeps, loaded in the "Dwell File" field of the Generator Function panel Frequency of the generator or of the selective RMS measurement; loaded in the Generator Function panel ("Freq File", "Mean Freq File", "Upper Freq File" fields) or in the Analyzer Function panel ("File Name" field) Burst interval; loaded in the "Interval File" field of the Generator Function panel Burst duration; loaded in the Generator Function panel. On Time File menu item Generator voltage; loaded in the "Volt File" or "Tot Volt File" field (depending on the function) of the Generator Function panel
Files for data or limit lists	.LIM	Limit curve, loaded in the configuration panels for measurement windows under "Limit Upper" and "Limit Lower"
	.TRC	Trace lists for measured values, loaded in the configuration panels for measurement windows
Graphic files	.BMP	Pixel graphic
Other instrument files	.ARB	Time table for generating arbitrary signals
	.AWD	Timetable for generating arbitrary signals in the format of the output file of the Arbitrary Waveform Designer, which was used in the R&S UPL.

File type	File extension	Meaning
	.WAV	Standard format for audio signals to allow processing with PC sound cards
Filter files	.COE	Coefficient file for file-defined filters, loaded in the Filter panel in the "File Name" field
	.NPZ .XPZ .ZPZ	Pole/zero file for file-defined filters, loaded in the Filter panel in the "File Name" field
Audio files	.AC3	Audio file format for the Dolby Digital® (DD) multichannel sound system.
	.EC3	Audio file format for the Dolby Digital Plus® (DD+) multichannel sound system.

4.16 Manual Remote Operation

The R&S UPP permits manual remote operation using an external computer. As a result, the audio analyzer can be operated conveniently from the user's desk even if, for example, the audio analyzer is installed in a rack in a different room.

Unlike **remote operation** where remote-control commands are used, the **manual remote operation** requires separate Windows software which is installed on the external computer. When launched, the Windows software **Remote Desktop Connection** simulates the user interface of the R&S UPP. This allows the instrument to be manually operated at the external computer in the same way as at the instrument itself.

Manual remote operation is only possible if the audio analyzer and computer are connected via LAN and the Windows software is installed on the computer.

Establishing the connection and installation of the remote-control software on the external PC is described in [Chapter 2.10.4, "Configuration for manual remote operation"](#), on page 54.

Manual remote operation is started on the external computer by calling up the Remote Desktop Connection program and clicking on the Connect button. The R&S UPP must be selected as the remote operation device, i.e. its computer name must be displayed in the Computer: If the computer has been configured for remote operation of more than one instrument, the desired instrument can be

selected from the list which is displayed by clicking the ▾ button. The user ID and password (**instrument** in both cases) can be stored when the software is first installed. The entry is possible in the expanded "Options>>" menu.

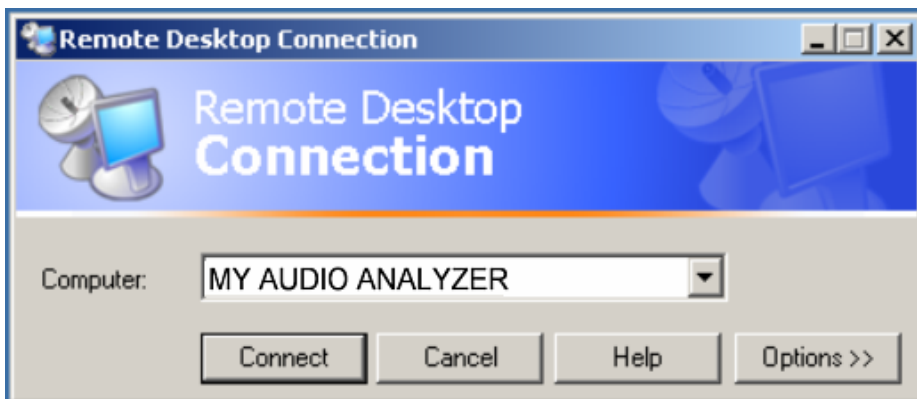

After logon, the instrument firmware of R&S UPP boots on the external computer. After the completion of the boot process, the screen of the audio analyzer appears and the R&S UPP can be manually remote-controlled from the external computer. The starting configuration is that which was active before the connection was set up. The individual functions are operated using the mouse and panel.

When establishing the connection, the instrument firmware at the R&S UPP is exited. During the manual remote control, it is not possible to perform any operations at the R&S UPP itself. Access by an external computer and the identity of the remote user is indicated on the login display of Windows.

To return to direct operation at the R&S UPP, it is necessary to log off the external user and log on the local user.

The external user can be logged off at the external computer in the "Start" menu of the R&S UPP window by clicking on "Disconnect" in the bottom right menu area.

Logging off is also possible directly at the R&S UPP in the remote control window.

The local user can be logged on at the R&S UPP in the remote control screen only after pressing the shortcut Ctrl + Alt + Del. By default, the R&S UPP uses **instrument** for this user name, and the password is also **instrument**.

After login, the instrument software starts with the settings used for manual remote operation.

4.17 Units

The R&S UPP features two types of units:

- Units for measurement result display:**
 In the configuration panels for the measurement displays, a display unit must be selected for each measurement function. This unit is then used for the measurement result displayed in the measurement display windows. The unit is selected in the Unit fields of the respective panel.
- Units for value entries** (e.g. reference values, frequencies, levels, etc.):
 When data is entered, the available units are displayed on the softkeys. This allows value entries to be adopted by selecting the unit without a further entry window having to be opened.

4.17.1 Units in Measurement Result Displays

To simplify matters: In the following conversion formulas, the entry values are designated by the unit only. Example: "dBu" means: value in "dBu".

4.17.1.1 Units for analog level measurement results

Basic unit: V

Value in	IEC/IEEE-bus notation	Conversion formula
V	V	
dBV	DBV	$20 \times \lg(V)$
dBu	DBU	$20 \times \lg(V/0.7745967)$
dBm	DBM	$10 \times \lg(V^2 \times 1000/R_{REF})$
W	W	V^2/R_{REF}
$\Delta\%V$	DPCTV	$(V/U_{REF}-1) \times 100$
ΔV	DV	$V-U_{REF}$
V/Vr	VVR	V/U_{REF}
$\%V/Vr$	PCTVVR	$100 \times V/U_{REF}$
$\Delta\%W$	DPCTW	$((V^2/R_{REF})/P_{REF}) \times 100$
ΔW	DW	$(V^2/R_{REF}) - P_{REF}$
P/Pr	PPR	$(V^2/R_{REF})/P_{REF}$
$\%P/Pr$	PCTPPR	$(V^2/R_{REF})/P_{REF} \times 100$
dBr	DBR	$20 \times \lg(V/U_{REF})$

R_{REF} = Reference impedance (Ref Imped) from *Analyzer Config* panel

U_{REF} = Reference level (Reference) from *Config* panel for measurement function

P_{REF} = $(U_{REF})^2/R_{REF}$

4.17.1.2 Units for digital level measurement results

Basic unit: FS (Full Scale)

Value in	IEC/IEEE-bus notation	Conversion formula
FS	FS	
%FS	PCTFS	$FS \times 100$
dBFS	DBFS	$20 \times \lg (FS)$
Hex *)	HEX	$FS \times (2^{\text{Audiobits}-1})$ for FS > 0 $FS \times (2^{\text{Audiobits}-1}) + (2^{\text{Audiobits}-1})$ for FS < 0
$\Delta\%$	DPCT	$(FS/U_{REF}-1) \times 100$
dBr	DBR	$20 \times \lg (FS/U_{REF})$
LSBs	LSBS	$FS \times 2^{\text{Audiobits}-1}$
bits	BITS	$1 + \lg (FS \times 2^{\text{Audiobits}-1})$

U_{REF} = Reference level (Reference) from *Config* panel for measurement function

*) Level measurement result in hex notation

All digital analyzer measurement functions usually deliver values ranging from 0 to 1 FS.

FS values >1 may occur in the following cases:

- In the case of the "Peak" measurement function with "Meas Mode" "Peak to Peak"
- In the case of a filter with gain (e.g. CCIR wtd) is used.

4.17.1.3 Units for distortion measurement results

Basic unit: %

Value in	IEC/IEEE-bus notation	Conversion formula
%	PCT	
dB	DB	$20 \times \lg (\% / 100)$

In the case of SINAD: $-20 \times \lg (\% / 100)$

4.17.1.4 Unit for S/N measurement results

Value in	IEC/IEEE-bus notation	Formula
dB	DB	$20 \times \lg(S/N)$

S: Measurement level with activated generator
N: Measurement level with deactivated generator

4.17.1.5 Units for frequency measurement results

Basic unit: Hz

Value in	IEC/IEEE-bus notation	Conversion formula
Hz	HZ	
Δ Hz	DHZ	$\text{Hz} - F_{\text{REF}}$
$\Delta\%$ Hz	DPCTHZ	$100 \times (\text{Hz} - F_{\text{REF}}) / F_{\text{REF}}$
Toct *	TOCT	$\lg (\text{Hz} / F_{\text{REF}}) \times 9.96578$
Oct	OCT	$\lg (\text{Hz} / F_{\text{REF}}) \times 3.32193$
Dec	DEC	$\lg (\text{Hz} / F_{\text{REF}})$
f/fr	FFR	$\text{Hz} / F_{\text{REF}}$

*) Toct = Third octave

F_{REF} = Reference frequency (Ref Freq) from *Freq Phase Config* panel for frequency measurement

4.17.1.6 Units for phase measurement results

Basic unit: ° (degrees)

Value in	IEC/IEEE-bus notation	Conversion formula
°	DEG	
RAD	RAD	$^{\circ} \times \pi / 180$
Δ°	DDEG	$^{\circ} - P_{\text{REF}}$
Δ RAD	DRAD	$(^{\circ} - P_{\text{REF}}) \times \pi / 180$

P_{REF} = Reference phase (Ref Phase) from *Freq Phase Config* panel for phase measurement

4.17.1.7 Units for group delay measurement results

Basic unit: s

Value in	IEC/IEEE-bus notation	Conversion formula
s	S	
Δ s	DS	$\text{s} - T_{\text{REF}}$

T_{REF} = Reference time (Ref Grp Del) from *Freq Phase Config* panel for group delay measurement

4.17.2 Units for Value Entries

To simplify matters: In the following conversion formulas, the entry values are designated by the unit only. Example: "dBu" means: value in "dBu".

Absolute analog level units (without reference)

Conversion formulae		IEC/IEEE-bus notation
V, mV, μ V		V, MV, UV
Vpp, mVpp, μ Vpp (peak-to-peak voltage of signal)		VPP, MVPP, UVPP
$dBu = 20 \times \lg (V/0.7746)$	$V = 0.7746 \times 10^{(dBu/20)}$	DBU
$dBV = 20 \times \lg (V)$	$V = 10^{(dBV/20)}$	DBV
$dBm = 10 \times \lg (V^2 \times 1000/R_{REF})^*$	$V = \sqrt{10^{(dBm/10)} \cdot R_{REF} / 1000}$	DBM
$W = V^2/R_{REF}$	$V = \sqrt{(W \cdot R_{REF})}$	W, MW, UW

R_{REF} = Reference impedance (Ref Imped) from the *Analyzer Config* panel

*) In the case of the generator, the reference impedance R_{REF} is always 600 Ohm. The IEC/IEEE-bus notation is DBMG. To calculate the open-circuit voltage V_0 , the source impedance R_s (Impedance) from the *Generator Config* panel is also taken into account, which means that $V = V_0 \times R_{REF} / (R_s + R_{REF})$ is to be used in the above formula.

Relative analog level units (with reference)

Conversion formulae		IEC/IEEE-bus notation
$\Delta V = V - U_{REF}$	$V = \Delta V + U_{REF}$	DV, DMV, DUV
$\Delta\%V = (V/U_{REF} - 1) \times 100$	$V = U_{REF} \times (1 + \Delta\%V/100)$	DPCTV
$VNr = V/U_{REF}$	$V = VNr \times U_{REF}$	VVR
$dBr = 20 \times \lg (V/U_{REF})$	$V = 10^{(dBr/20)} \times U_{REF}$	DBR
$V/on = V/\text{Burst amp}[V]$	$V = V/on \cdot \text{Burst amp}[V]$	VON
$\%on = 100 \cdot V/\text{Burst amp}[V]$	$V = \%on \cdot \text{Burst amp}[V]/100$	PCTON
$dBon = 20 \cdot \lg (V/\text{Burst amp}[V])$	$V = 10^{(dBon/20)} \cdot \text{Burst amp}[V]$	DBON

U_{REF} = Reference level (Ref Voltage) in V from the *Generator Config* panel

Absolute digital level units (without reference)

Conversion formulae		IEC/IEEE-bus notation
FS		FS
$\text{bits} = 1 + \lg (FS \times 2^{\text{Audio bits}-1})$	$FS = 2^{\text{bits}-1} / 2^{\text{Audio bits}-1}$	BITS
$\%FS = 100 \times FS$	$FS = \%FS/100$	PCTFS
$dBFS = 20 \times \lg (FS)$	$FS = 10^{(dBFS/20)}$	DBFS
$LSBS = FS \times 2^{\text{Audio bits}-1}$	$FS = LSBS / 2^{\text{Audio bits}-1}$	LSBS

Relative digital level units (with reference)

Conversion formulae		IEC/IEEE-bus notation
$dBr = 20 \times \lg (FS/U_{REF})$	$FS = 10^{(dBr/20)} \times U_{REF}$	DBR
$\Delta\% = 100 \times (FS/U_{REF} - 1)$	$FS = (\Delta\% / 100 + 1) \times U_{REF}$	DPCT
$\%on = 100 \times FS/\text{Burst amp}[FS]$	$FS = \%on \times \text{Burst amp}[FS]/100$	PCTON
$dBon = 20 \times \lg (FS/\text{Burst amp}[FS])$	$FS = 10^{(dBon/20)} \times \text{Burst amp}[FS]$	DBON

U_{REF} = Reference level (Ref Voltage) in FS from the *Generator Config* panel

Absolute time units

Conversion formulae		IEC/IEEE-bus notation
s		S, MS, US
min = 60 s	s = min / 60	MIN
cyc = s × signal frequency	s = cyc / signal frequency	CYC, KCYC, M CYC

Absolute frequency units

Conversion formulae		IEC/IEEE-bus notation
Hz, kHz		HZ, KHZ

Relative frequency units (with reference)

Conversion formulae		IEC/IEEE-bus notation
$\Delta\text{Hz} = \text{Hz} - F_{\text{REF}}$	$\text{Hz} = \Delta\text{Hz} + F_{\text{REF}}$	DHZ, DKHZ
$f/\text{fr} = \text{Hz}/F_{\text{REF}}$	$\text{Hz} = f/\text{fr} \times F_{\text{REF}}$	FFR
$\Delta\%\text{Hz} = 100 \times (\text{Hz} - F_{\text{REF}})/F_{\text{REF}}$	$\text{Hz} = (\Delta\%\text{Hz}/100 + 1) \times F_{\text{REF}}$	DPCTHZ
$\text{Toct} = \lg(\text{Hz}/F_{\text{REF}}) \times 9.96578$	$\text{Hz} = 2^{\text{Toct}/3} \times F_{\text{REF}}$	TOCT
$\text{Oct} = \lg(\text{Hz}/F_{\text{REF}}) \times 3.32193$	$\text{Hz} = 2^{\text{Oct}} \times F_{\text{REF}}$	OCT
$\text{Dec} = \lg(\text{Hz}/F_{\text{REF}})$	$\text{Hz} = 10^{\text{Dec}} \times F_{\text{REF}}$	DEC
(Toct = Third octave)		

F_{REF} = Reference frequency (Ref Frequency) from the *Generator Config* panel

Absolute phase units

Conversion formulae		IEC/IEEE-bus notation
°		DEG
rad = ° × ($\pi/180$)	° = rad × ($180/\pi$)	RAD

Deviations (tolerance) relative to previous measured values in settling function

Conversion formulae		IEC/IEEE-bus notation
$\% = (10^{\text{dB}/20} - 1) \times 100$	$\text{dB} = 20 \times \lg(\%/100 + 1)$	DB, PCT

Step size of a logarithmic level sweep

Conversion formulae		IEC/IEEE-bus notation
$\text{MLT} = 10^{\text{dB}/20}$	$\text{dB} = 20 \times \lg(\text{MLT})$	[MLT], DB

Absolute resistance unit

Conversion formulae	IEC/IEEE-bus notation
Ω	OHM, KOHM

4.18 Overview of Keys

The following table provides an overview of the shortcuts of the PC keyboard and the mouse operation and its function.

Table 4-1: Softkeys

Key of the PC keyboard Operation with mouse	Function
F5 to F12	Triggers the function assigned to the softkey.

Table 4-2: CONTROL panel

Key of the PC keyboard Operation with mouse	Function
CTRL + F5	Starts continuous measurements and sweeps Resets the Min/Max values for bar graph displays, averaging for measurement results, and limit overranging
CTRL + F6	Starts a single measurement or a single sweep
CTRL + F7	Measurement / sweep is stopped or continued (toggle function)
CTRL + F8	Switches the audio monitor on and off (toggle function)
CTRL + F9	Opens / closes the window for adjusting the audio monitoring volume
CTRL + P	Depending on the settings under Utilities, printout of the screen contents on the connected printer is started or the screen contents are stored in a file
CTRL + F10	Stores the current settings on the hard disk and then shuts down the Windows® operating system
CTRL + F11	Switches the instrument from remote operation to manual operation
CTRL + F12	Switches the outputs of the measuring instrument off or on again (toggle function)

Table 4-3: Navigation keys

Key of the PC keyboard Operation with mouse	Function
CTRL+PAGE UP / CTRL + PAGE DOWN	Switches to the previous / next display setting (screen)
CTRL+SHIFT+TAB (left) / CTRL+TAB (right)	Switches the focus to the previous / next panel open in the visible screen (the panel with the focus is active)
ALT+PAGE UP / ALT * PAGE DOWN	Changes to the previous / next scan in graphical displays so that, for example, measured values can be read off using the cursor
PAGE DOWN / PAGE UP	Scrolls to the next/previous page in tables

Table 4-4: Data entry keys

Key of the PC keyboard Operation with mouse	Function
1...9 a to z	Number entry: 1...9 Letter entry: a to z
0 SPACE	Number entry: 0 Entry of a space
. * ... #	Entry of a period / decimal point; Entry of special characters
- (SHIFT +) A to Z	Entry of sign; Switchover between uppercase and lowercase letters

Table 4-5: VARIATION panel

Key of the PC keyboard Operation with mouse	Function
CTRL + M	Displays the menu bar on the screen
BACKSPACE	Deletes the character to the left of the cursor Undoes the action last performed
ESC	Closes the open panel; the old value or parameter is retained
ENTER Left-click Turn mouse wheel	Completes the data entry (the new value is adopted); confirms and closes open entry windows

Key of the PC keyboard Operation with mouse	Function
TAB (to the right) SHIFT+TAB (to the left) Turn mouse wheel	Moves the focus in the panels, selection windows and tables Varies the entry value at the cursor position Moves the active cursor in the graphical windows Switches the measuring steps forwards and backwards for manual sweeps
UP/DOWN cursor keys	Move the focus in the panels, selection windows and tables Change the entry value at the cursor position
LEFT/RIGHT cursor keys	Moves the active cursor inside the graphical windows Move the cursor position in entered values Switch the measuring steps forwards and backwards for manual sweeps

Table 4-6: WINDOW and SETUP panels

Key of the PC keyboard Operation with mouse	Function
ALT + W	Toggles between the softkey bar and the WINBAR
ALT + M	Opens a selection of functions on the softkey bar; these functions can be used to move or resize the active panel or graphical window
ALT + H	Minimizes ("hides") the active panel or graphical window
ALT + C	Closes the active panel or graphical window
F1	Opens and closes the context-sensitive help function
ALT + S	Opens a panel for storing instrument settings
ALT + L	Opens a panel for loading predefined instrument settings
ALT + P	Loads the factory settings of the instrument

4.19 Overview of Panels and Measurement Displays (Graphical Windows)

Panels which can be selected via the Instruments menu bar button:

Generator Config	<ul style="list-style-type: none"> • Selection of instrument (analog or digital interfaces) • Configuration of channels • Bandwidth and sampling rate • Reference values • Synchronization settings and word length (for digital interfaces)
Generator Function	<ul style="list-style-type: none"> • Selection of test signals • Sweep function • Frequency and level settings • Filter and equalizer
Analyzer Config	<ul style="list-style-type: none"> • Selection of instrument (analog or digital interfaces) • Configuration of channels • Measurement bandwidth and sampling rate • Reference impedance • Start and trigger conditions
Analyzer Function	<ul style="list-style-type: none"> • Selection of measurement functions • Measurement speed and accuracy • Activation of filter and equalizer • Activation of Post FFT • Selection and settings for level monitor • Selection and settings for input monitor • Selection and settings for frequency, phase, group delay measurement • Selection and settings for waveform monitor
Filter	<ul style="list-style-type: none"> • Definition of filter properties
Auxiliaries	<p>Audio Monitor</p> <ul style="list-style-type: none"> • Settings for the two BNC monitor sockets at the rear of the instrument • Switch-on/switch-off function • Signal source and channels • Output level

Overview of Panels and Measurement Displays (Graphical Windows)

Switcher Panel	<ul style="list-style-type: none"> Function settings and operation of one or more connected Audio Switchers R&S UPZ. At the UPP, the switcher is connected via a USB-to-serial adapter which is mapped to an open COM port by Windows. This port is also indicated in the panel.
Protocol Generator	<ul style="list-style-type: none"> Settings for the generator functions for generating the digital audio protocol of the R&S UPP-B2 option (digital audio interfaces).

Panels which can be selected via the Disp Config menu bar button

Function Config	<ul style="list-style-type: none"> Settings for measured values of active measurement function in numeric display field Settings for associated combo displays Settings for limits, minimum values and maximum values
Level Monitor Config	<ul style="list-style-type: none"> Settings for numeric measured values of level monitor in numeric display field Settings for associated combo displays Settings for limits, minimum values and maximum values
Input Config	<ul style="list-style-type: none"> Settings for measured values of input monitor in numeric display field Settings for associated combo displays Settings for limits, minimum values and maximum values
Freq Phase Config	<ul style="list-style-type: none"> Settings for measured values of frequency, phase and group delay measurement in numeric display field Settings for associated combo displays Settings for limits, minimum values and maximum values
Sweep Graph 1 to 4 Config	<ul style="list-style-type: none"> Four of these panels are available so that up to 4 sweep graphical windows can be displayed simultaneously Setting of all details for one-channel or two-channel graphical display of sweep functions, e.g. units, scaling, gridlines, etc. Evaluation of minimum and maximum values Entry of limit curves Settings for cursors and markers
FFT Graph 1 to 2 Config	<ul style="list-style-type: none"> Two of these panels are available so that up to 2 FFT graphical windows can be displayed simultaneously Setting of all details for one-channel or two-channel display of FFT graph, e.g. units, scaling, gridlines, etc. Evaluation of minimum and maximum values Entry of limit curves Settings for cursors and markers

Overview of Panels and Measurement Displays (Graphical Windows)

Waveform Config	<ul style="list-style-type: none"> • Setting of all details for graphical display of waveform analyzer, e.g. number of curves, units, scaling, gridlines, etc. • Entry of limit curves • Settings for cursors and markers
Bar Graph 1 to 2 Config	<ul style="list-style-type: none"> • Two of these panels are available so that up to 2 bar graph windows can be displayed simultaneously • Setting of all details for one-channel or two-channel display of bar graphs, e.g. units, scaling, gridlines, etc. • Evaluation of minimum and maximum values • Entry of limits • Settings for cursors and markers

Measurement windows which can be selected via the Displays menu bar button:

Numeric Display	<ul style="list-style-type: none"> • Display of measurement results for measurement function selected in the "Analyzer Function" panel • Display of measurement results for level monitor selected in the "Analyzer Function" panel • Display of measurement results for input monitor selected in the "Analyzer Function" panel • Display of frequency measurement results or frequency measurement result and phase or group delay measurement results • The measurement results are displayed in the way defined in the configuration panel
Funct Ch1 to 2 Funct ...	<ul style="list-style-type: none"> • These combo displays are extensions to the numeric measurement displays of the measurement function selected in the "Analyzer Function" panel; they show the respective numeric value plus the following additional features: <ul style="list-style-type: none"> • Analog bar graphs • Monitoring and display of limits • Storage of minimum and maximum values • The measurement results are displayed in the way defined in the configuration panel
Lev Mon Ch1 to 2 Lev Mon ...	<ul style="list-style-type: none"> • These combo displays are extensions to the numeric measurement display of the level monitor selected in the "Analyzer Function" panel; they show the respective numeric value plus the following additional features: <ul style="list-style-type: none"> • Analog bar graphs • Monitoring and display of limits • Storage of minimum and maximum values • The measurement results are displayed in the way defined in the configuration panel

Overview of Panels and Measurement Displays (Graphical Windows)

Input Ch1 to Ch2 Input ...	<ul style="list-style-type: none"> • These combo displays are extensions to the numeric measurement display of the input monitor selected in the "Analyzer Function" panel; they show the respective numeric value plus the following additional features: <ul style="list-style-type: none"> • Analog bar graphs • Monitoring and display of limits • Storage of minimum and maximum values • The measurement results are displayed in the way defined in the configuration panel
Freq Ch1 Phase Ch2/Ch1 Freq/Phase ...	<ul style="list-style-type: none"> • These combo displays are extensions to the numeric measurement display of the frequency/phase measurement selected in the "Analyzer Function" panel; they show the respective numeric value plus the following additional features <ul style="list-style-type: none"> • Analog bar graphs • Monitoring and display of limits • Storage of minimum and maximum values • The measurement results are displayed in the way defined in the configuration panel
Sweep Graph 1 to 4	<ul style="list-style-type: none"> • Up to four of these display windows can be open simultaneously to display scans from sweep measurements <ul style="list-style-type: none"> • One-channel or two-channel graphical display • The measurement results are displayed in the way defined in the respective "Sweep Graph 1 to 4 Config" configuration panel
FFT Graph 1 to 2	<ul style="list-style-type: none"> • Up to two of these display windows can be open simultaneously to display the FFT analyses of the selected measurement function or of the Post FFT <ul style="list-style-type: none"> • One-channel or two-channel graphical display • The measurement results are displayed in the way defined in the respective "FFT Graph 1 to 2 Config" configuration panel
Waveform	<ul style="list-style-type: none"> • This display window shows the characteristic of the measurement signal over time <ul style="list-style-type: none"> • One-channel or two-channel graphical display • The measurement results are displayed in the way defined in the "Waveform Config" configuration panel
Bar Graph 1 to 2	<ul style="list-style-type: none"> • Up to two of these display windows can be opened to display bar graphs of the selected measurement function <ul style="list-style-type: none"> • One-channel or two-channel graphical display • The measurement results are displayed in the manner defined in the respective "Bar Graph 1 to 2 Config" configuration panel

4.20 Overview of Status Messages

The status of the R&S UPP is continuously displayed for the generator, analyzer, sweep system and other instrument states at the bottom of the screen in four fields above the four right-hand softkeys.

Status displays always appear at the same position; they are assigned to the fields above the softkeys as shown below.

			Analog Analyzer Channels	Generator	Sweep
Anlr Cont			12345678	Gen Running	Sweep Off
Analog	Digital Audio	I2S			
Anlr1 Cont			Anlr2 Cont	Gen Running	Sweep Off
Analog	Digital Audio	I2S			
			Digital Analyzer Channels Ch1		
			Ch2		

The following overview shows the possible status messages and their meaning:

Analyzer status - Status information for the channels Anlr

For the UPP, the status displays of the channels are compressed to one row with a character coding. One character corresponds to each channel viewed from left to right, whereby a switched-off channel is marked with a black line, a switched-on channel with the respective number in green. The conditions Overrange and Underrange are indicated by a color marking (red or black)

Status display for channel	
-	Measurement channel is deactivated
Number in green	Measurement channel is correctly modulated
Number in red	Measuring range has been overranged; this can occur if: <ul style="list-style-type: none"> • Range Fix setting is being used • A signal with a level at range limit is applied with a crest factor > 2 • Common-mode voltage is applied in BAL input configuration
Number in black	Measuring range has been underranged; this can occur if Range Fix or Lowest setting is being used
Other status display	
Single	Single measurement is being performed
Cont	Continuous measurement is being performed
Terminated	Single measurement has been terminated

Overview of Status Messages

Stopped	Measurement has been stopped
Wait for Trigger	Analyzer is waiting for set trigger condition

Generator status

Gen Off	Generator is deactivated
Gen Running	Generator signals are being output
Output Off	All output lines are deactivated
Gen Overload	Generator has been deactivated owing to overload

Sweep status

Sweep Off	No sweep is being performed
Sweep Waiting	Sweep has been defined but not yet started
Sweep Terminated	Single sweep has been terminated
Sweep Stopped	Sweep has been stopped but can be continued
Sweep Run Cont	Continuous sweep is being performed
Sweep Run Single	Single sweep is being performed
Sweep Run Manual	Manual sweep is being performed

Index

Symbols

19" rack 26

A

AC supply 27

Activate monitor 37

Activate panel 130

Analysis

 with cursors 171

 with markers 171

Analyzer status 211

Audio Monitor 192

Auxiliaries panel 191

B

Backup

 Windows 7 64

 Windows XP 59

Bar Graph 163

BIOS version 28

Booting 28

Brief introduction, operation 72

Button Sequence 183, 186

C

Changing unit 143

Clipping level 144

Close All button 127

Close panel 130

Combo display 154

Combo fields setting 155

Computer keyboard 123

Computer name 55

Cont 211

Conversion formulas 199

Conversion formulas for analog level measurement results 199

Converting units 199

D

DC Adjusting 211

Device indicator 48

DHCP networks 39

Directories in the network 45

DispConfig button 185

Display 125

Display window 130

Displays button 183, 186

E

Edit button 184

Electrical discharges 24

EMC protective measures 24

EN61010-1 27

Entering the IP Address 41

Ethernet 38

Example

 Measuring frequency response 91

 Measuring total harmonic distortion .. 103

Example setups 112

External keyboard 34

External software 32

F

Factory default setting 67

Factory Default setting 62

FFT Graph 161

File button 183

File Extensions 196

File Management 195

Firewall 38

Firmware Update 58

Fix All Sizes button 127

Fix Size Auto Size button 127

Frequency response 144

Full Screen button 127

Function level 118

Functional testing 30

G

Gen Off 212

Gen Overload 212

Gen Running 212

Generator status 212

Getting started 69

Graphical window 159

H

Help button 183, 189

Help System 193

Hide panel 130

Horiz Size button 127

Hum loops, avoiding 70

- I**
- Input Help 87, 148
 - Input level 118
 - Input voltage, permissible 27
 - Instrument Concept 115
 - Instrument feet 25
 - Instrument settings
 - /saving/loading 195
 - Instruments button 185
 - IP address 55
- K**
- Keyboard 34
- L**
- LAN configuration
 - Password 49
 - LAN connection 38
 - LAN LED 48
 - LED
 - LAN 48
 - Load
 - Instrument settings 195
 - Traces 171
 - Loading Predefined Instrument Setups . 112
 - LXI (LAN eXtensions) 46
 - LXI browser interface 49
 - LXI website 48
- M**
- Manual operation 114
 - Manual Remote Operation 54, 197
 - Maximum output voltage 70
 - Measured value Display in Lists 180
 - Measurement result display in numeric display field 153
 - Monitor
 - Connecting 35
 - Monitor level 118
 - Mouse 34
 - Moving graphical windows 127
 - Moving panels 127
- N**
- Navigating in lists 181
 - Negotiation 52
 - Network connector 38
 - Network directories 45
 - Next Bin 175
 - Next Peak 175
 - Next Pixel 175
 - Next Sample 176
 - Next Step 175
 - Next Value 176
- O**
- Open panel 130
 - Operating concept 114
 - Operating examples 91
 - Operation with mouse 122
 - Option
 - Installation 38
 - Output Off 212
 - Output voltage, limiting 70
 - Over 211
 - Overload 211
 - Overview of Keys 204
- P**
- Panel
 - Overview 207
 - Panels 129
 - Parameter fields 131
 - Password 40
 - LAN configuration 49
 - Ping Client 53
 - Point-to-point connections 40
 - Power supply connection 27
 - Presets 30
- Q**
- Querying the computer name 44
- R**
- Rack adapter 26
 - Rack installation 24
 - Rapid Deactivation of Outputs 193
 - Rated voltages 27
 - Recovery
 - Windows 7 64
 - Windows XP 59
 - Reference values 144
 - Remote control
 - Manual 54
 - Remote desktop 54
 - Resizing graphical windows 127
 - Resizing panels 127
 - Risk of overheating 26

S

Safety precautions	22
Save	
Instrument settings	195
Traces	171
Scaling graph	173
Screen resolution	35
Screens	125
Screens button	184
Settings in the Menu Bar	182
Settings in the Operating System	191
Settings on the Toolbar	190
Shortcut	
CTRL + ALT + F1	37
CTRL + ALT + F3	37
CTRL + ALT + F4	37
Single	211
Softkeys	126
Software lockup	28
Splash screen	28
Status Displays	128
Status messages	211
Stopped	211
Sweep graph	160
Sweep Off	212
Sweep Run Cont	212
Sweep Run Manual	212
Sweep Run Single	212
Sweep status	212
Sweep Stopped	212
Sweep Terminated	212
Sweep Waiting	212
Switching on the instrument	28
System partition	61, 67
T	
Terminated	211
Title bar	132
Total load	25
Traces	
Saving	171
showing and hiding	172
Track box	147
Trigger output	193
Trigger Output	193
U	
Under	211
Unit for S/N measurement results	200

Unit of measurement result	156
Units	199
Units for digital level measurement results	200
Units for distortion measurement results	200
Units for frequency measurement results	201
Units for group delay measurement results	201
Units for phase measurement results	201
Units for Value Entries	201
Universal generator	115
User ID	40
Utilities button	183, 187
Utilities Config panel, General Configuration settings	189

V

Valid Value Range	128
Value range, permissible	128
Vert Move button	127
Vert Size button	127
Volume	192
Volume key	192
VXI-11 Discovery	52

W

Wait for DC Adj	211
Wait for Trigger	211
Warm start	28
Warnings	129
Waveform	162
Windows	32
Windows 7 Recovery and Backup	64
Windows button	183, 189
Windows XP Recovery and Backup	59

X

X-axis	170, 171
--------------	----------

Y

Y-axis	166
--------------	-----