

225/2021

NEWS

ROHDE & SCHWARZ

Make ideas real



PICTURING TIME

Oscilloscopes are indispensable instruments in electronics labs. They can display much more than signal paths.



Novel testing solution
for automotive radars

Source measure units reliably measure
extremely small currents and voltages

The ICARUS animal tracking project
has commenced operations

NEWS

Published by
Rohde & Schwarz GmbH & Co. KG
Mühlldorfstrasse 15 · 81671 München
www.rohde-schwarz.com

Regional contact

- ▶ Europe, Africa, Middle East | +49 89 4129 12345
customersupport@rohde-schwarz.com
- ▶ North America | 1 888 TEST RSA (1 888 837 87 72)
customer.support@rsa.rohde-schwarz.com
- ▶ Latin America | +1 410 910 79 88
customersupport.la@rohde-schwarz.com
- ▶ Asia Pacific | +65 65 13 04 88
customersupport.asia@rohde-schwarz.com
- ▶ China | +86 800 810 8228 | +86 400 650 5896
customersupport.china@rohde-schwarz.com

Emails to the editor: newsmagazine@rohde-schwarz.com

Chief editor: Volker Bach, Rohde & Schwarz
Editor and layout: Redaktion Drexl & Knobloch GmbH (German)
English translation: Dept. GF-BS2
Photos: Rohde & Schwarz

Printed in Germany
Circulation (German, English and Japanese)
approx. 20 000 two times a year

Volume 61
Issue 2/2021, no. 225

ISSN 0028-9108
Supply free of charge through your nearest
Rohde & Schwarz representative
Reproduction of extracts permitted if source is stated and copy sent
to Rohde & Schwarz München.

PD 3609.7460.72

R&S® is a registered trademark of Rohde & Schwarz GmbH & Co. KG.
Trade names are trademarks of the owners. CDMA2000® is a reg-
istered trademark of the Telecommunications Industry Association
(TIA-USA). The Bluetooth® word mark and logos are registered trade-
marks owned by the Bluetooth SIG, Inc. and any use of such marks
by Rohde & Schwarz is under license. All other trademarks are the
properties of their respective owners.

COVER FEATURE

Of all T&M instruments, oscilloscopes have benefitted most from digital technology. A time traveler from the analog era would only recognize current models by the key terms on the front panel and typical measurement displays such as the eye diagram. After being bound by tube technology for decades, the instruments have become fully emancipated from their roots. Nowadays, the measurement signal is digitized at the input and analyses can be performed using the data. Of course, oscilloscopes are still purchased to examine signals in the time domain. A rich variety of software offers T&M experts countless opportunities to answer their questions about a signal and leave none unanswered. The instruments have also long been poaching from other classes. Logic analyzers are no longer needed since modern oscilloscopes can perform their tasks on the side. Spectrum analysis is now also part of their repertoire. FFT allows for a shift in the frequency perspective to include an alternative view of the signal in the analysis. The presentation of the results and controls in current instruments are just as impressive as the technology. Large format touchscreens with rich contrast and colors can be used to arrange displays as needed and make lab work a pleasure.

The new R&S®RT06 embodies all benefits of modern oscilloscopes (page 28). The third generation of the midrange family from Rohde & Schwarz has been consistently designed for usability, focusing on the fastest path to measurement success. A typical task is the analysis of bus signals. Two articles show how Ethernet, USB and other bus signals can be thoroughly tested using an oscilloscope (page 32 ff).

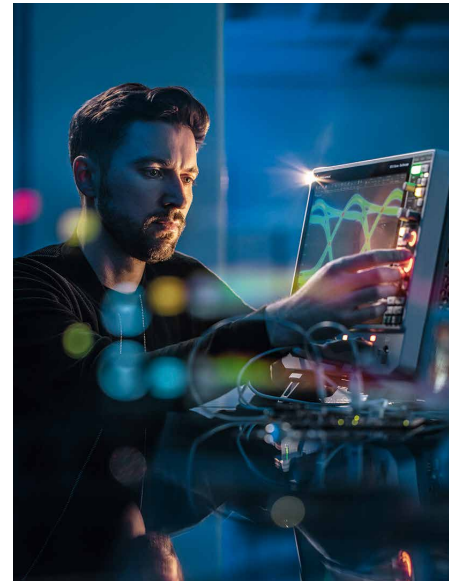

OVERVIEW

NEWS 225/2021

COVER FEATURE

Oscilloscopes

Generation leap

All-new and redesigned midrange instrument..... 28

Conformance test failed. What now?

Root cause analysis of signal integrity problems on high speed digital buses..... 32

WIRELESS

OTA measurements on 5G FR2 devices

Compact test chamber for measurements on 5G wireless devices is now even more versatile..... 12

Non-signaling flagship

The R&S®CMP180 rounds out the range of non-signaling testers..... 15

802.11be signal generation and analysis

Signal generators and signal analyzers open the door to the signal world of Wi-Fi 7 16

AUTOMOTIVE

Rush hour on the test bench

A new solution makes it possible to simulate complex radar scenarios 20

Your partner for automotive Ethernet

Automatic test solution supports the implementation of MultiGBASE-T1 in market-ready products. 26

A new pair of instruments enables extensive testing of automotive radars on the test bench and in the lab (page 20).

Measuring high speed data interfaces is a typical oscilloscope application (pages 26 and 32).

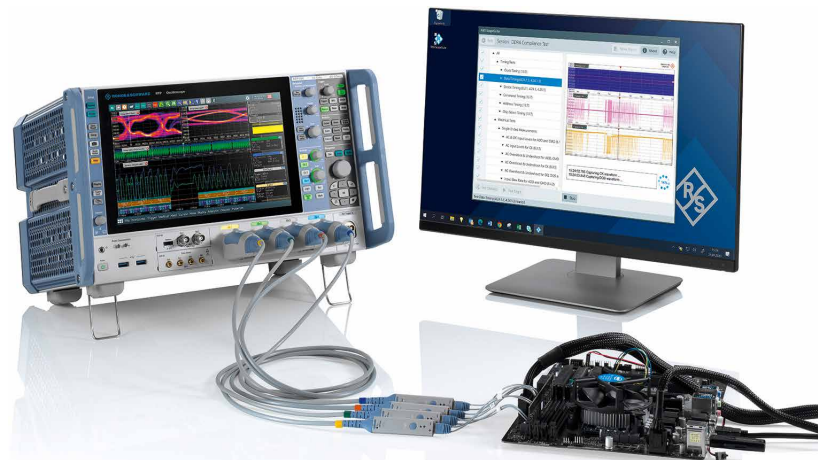



Network operators can equip their complete DAB+ networks with transmitters from Rohde & Schwarz and enjoy the benefits of one-stop shopping (page 42).

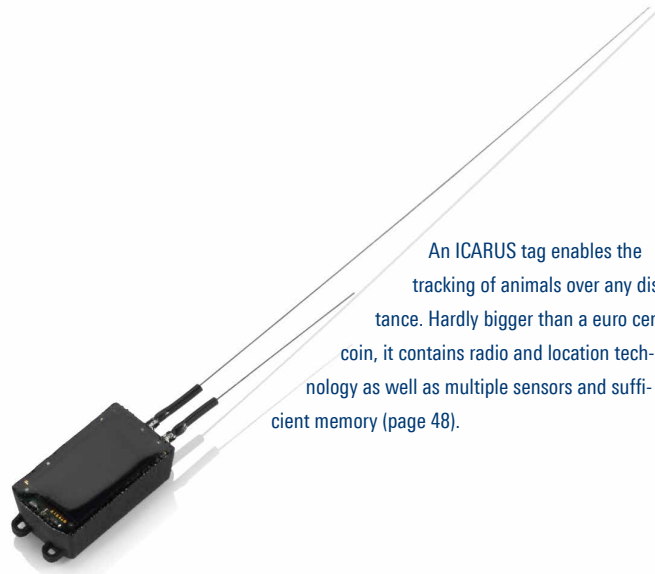

An ICARUS tag enables the tracking of animals over any distance. Hardly bigger than a euro cent coin, it contains radio and location technology as well as multiple sensors and sufficient memory (page 48).

GENERAL PURPOSE

Focusing on very low currents and voltages
Source measure units can measure and reliably supply extremely small currents and voltages 38

Realistic simulation of RF systems
Signal generation and analysis software for Cadence® Visual System Simulator™ 40

BROADCAST AND MEDIA

Coverage in every nook and cranny
Low-power transmitter eliminates coverage gaps in DAB+ networks..... 42

SECURE COMMUNICATIONS

Securely working from home
VS-NfD approved software tools 44

SATELLITE COMMUNICATIONS

ICARUS flies
The ISS based animal tracking project has commenced operations using radio technology from Rohde & Schwarz..... 48

Smart uplink amplifiers
The R&S®PKU100 satellite uplink amplifier provides an integrated system control for redundant configurations..... 52

MONITORING

Trouble makers in sight!
The R&S®ARDRONIS drone warning and counter system now also allows visual assessments of approaching drones 54

MISCELLANEOUS

Masthead 2
NEWS compact 6

With the two-quadrant R&S®NGU201 and its four-quadrant counterpart R&S®NGU401 (shown here), Rohde & Schwarz enters the market for precision source measure units (page 38).



A software option extends R&S®ARDONIS to control video cameras and directional antennas and automatically point them towards a detected target (page 54).



NEWS COMPACT



The Çamlıca Tower is the new landmark of Istanbul.

TEST SYSTEM FOR BCI MEASUREMENTS



The BCI test system can be configured with different generator and amplifier options.

A number of automotive EMC test regulations ensure that increasingly complex vehicle electronic systems are not affected by external interference. The requirements include immunity to high frequency electromagnetic interference coupled into vehicle buses and cable harnesses. This is tested by bulk current injection (BCI). Two measurement methods, described in the ISO 11452-1 and 11452-4 automotive test standards and application-independent in IEC/EN 61000-4-6, are commonly used for this: the substitution method and the closed-loop method, which differ only in the continuous monitoring of the applied RF power. One method requires two power meters in the test setup, while the other requires three. In both

cases the RF power, in the form of an amplitude modulated (AM) signal, is injected into the cable by an inductive coupler. This requires a simple signal generator, an RF power amplifier, and a directional coupler for connecting the power meter to the amplifier. The new, compact BCI system includes all of these components (except the inductive coupler). An R&S®SMB100B or R&S®SMC100A generates the AM signal between 9 kHz and 400 MHz, and an R&S®BBA150-AB (75 W, 125 W, 160 W, 200 W or 350 W) is used to amplify the signal. R&S®NRP6AN power sensors and an R&S®DDC25 directional coupler are also integrated. The system is directly supported by the R&S®EMC32 and R&S®ELEKTRA EMC test suites.

THE TOWER OF 100 TRANSMITTERS

The 388-meter Çamlıca Tower in Istanbul not only adds a modern landmark to complement the Hagia Sophia, but also influences the cityscape in another way. By taking over transmission of all FM radio

stations in the metropolitan region (start of transmission in September 2020), it eliminates the need for around 30 local transmitter masts, enhancing the Istanbul skyline.

The FM transmitters in the tower – no less than 100, spread over two floors – were supplied by Rohde&Schwarz. This transmitter density is unique worldwide and made possible by multiple R&S®THR9 space-saving design features, including a special water cooling concept from Rohde&Schwarz for the FM range.

Thanks to the high efficiency of the transmitters (up to 75 %), the very compact cooling system can easily handle heat dissipation. In addition, up to four transmitters can be installed in a 19-inch rack and operated together (multi-TX). These two features reduce the required space by up to 80 % compared to air-cooled designs.

The operator Kule Verici Tesisleri Isletim Ve Teknolojileri A.S. also appreciates the system's high energy efficiency, reducing both power costs and the environmental footprint.

HIGH-POWER RF AMPLIFIERS FOR HIRF APPLICATIONS

Aircraft can be briefly exposed to very strong electromagnetic fields from lightning strikes or radar pulses. To ensure that avionics equipment is not affected by this and does not suffer any damage, there are specific EMC standards for the aviation industry such as MIL-STD-464 and AECTP 250, which prescribe tests with high intensity radiated fields (HIRF). These are produced by signal generators and a downstream high-power amplifier. Based on the R&S®BBL200-A and R&S®BBA130-BC amplifier families

(see figure), suitable power packages can now be put together for RF CW power up to 13 kW. The R&S®BBL200-A series covers the frequency range from 9 kHz to 250 MHz (with 3 kW, 5 kW or 10 kW power), while the R&S®BBA130-BC series covers the range from 80 MHz to 1 GHz (with 6.5 kW, 9.5 kW or 13 kW). These solid-state amplifiers feature excellent linearity, mismatch tolerance and high reliability. A variety of signal generators, such as the R&S®SMB100A, can be used as the signal source.

A lot helps a lot: The generation of high field strengths requires an enormous amplifier effort.



R&S®CMA180 RADIO TESTER NOW EXTENDED TO 6 GHZ BANDWIDTH

The R&S®CMA180 radio test set for professional radios such as those used by security authorities and organizations, military forces and in air traffic control systems, is now even more versatile. An additional R&S CMW100 Communications Manufacturing Test Set extends its bandwidth up to 6 GHz and 160 MHz for testing up to eight ports according to standards such as WLAN, Bluetooth and LTE, which are increasingly found in land mobile radio (LMR) devices. Tactical radios that communicate using broadband waveforms also require high test bandwidth. The R&S®CMW100 extension unit is fully integrated in the R&S®CMA180 user interface and allows tests of eight devices in parallel, significantly boosting efficiency in production and in service centers with high throughput.

The R&S®CMW100 is fully integrated in the R&S®CMA180 user interface, allowing it to perform broadband measurements up to 6 GHz and test eight DUTs simultaneously.



NEW GENERATION OF NETWORK ENCRYPTORS APPROVED FOR RESTRICTED CLASSIFICATION LEVEL

R&S®SITLine ETH NG is an application-independent encryptor for intersite network communications of public authorities and companies. The R&S®SITLine ETH-L 19-inch version can encrypt up to four independent 10 Gbit/s lines, while the compact R&S®SITLine ETH-S can encrypt lines up to 1 Gbit/s. Both are approved by the German Federal Office for Information Security (BSI) up to classification levels VS-NfD (RESTRICTED), NATO RESTRICTED and EU RESTRICTED.

Unlike IPsec encryptors, which work at OSI layer 3 (internet layer), the R&S®SITLine ETH NG encrypts at layer 2. This not only reduces protocol overhead, resulting in higher net data rates, but also provides protection against operator errors in applications, for example when the wrong classification level is selected for a confidential internal email. It additionally protects the entire IP infrastructure against eavesdropping and manipulation, and provides independence from telecommunications providers and component suppliers.

The combination of plug-and-play installation and central management makes the solution user-friendly. The familiar R&S®Trusted Objects Manager used with other Rohde & Schwarz Cybersecurity products also serves as a security management system for R&S®SITLine ETH NG. Operating in a secure environment (data center with access control), the server acts as a certificate authority of a public key infrastructure for the encryptor. There is no central point of attack outside the protected area, so there is no single security risk because the session keys required for operation are independently negotiated by the devices.

Typical use cases for the R&S®SITLine ETH are networking of branch companies, data centers and public authority locations. For example, the German National Library uses R&S®SITLine ETH to safeguard synchronization of its databases in Frankfurt and Leipzig, and the German state Saarland has deployed it to connect its public authorities.



Scalable and highly secure at every configuration level: the R&S®SITLine ETH-L 19-inch rackmount and the ETH-S compact unit.



ROHDE & SCHWARZ ACQUIRES T&M EQUIPMENT MANUFACTURER FOR QUANTUM COMPUTING

Zurich Instruments AG, a 2008 spin-off of ETH Zurich with more than 100 employees in seven countries, joined the Rohde&Schwarz group on July 1, 2021, as a fully owned subsidiary. With this acquisition, Rohde&Schwarz adds a highly promising segment to its T&M equipment portfolio.

Zurich Instruments is a leading manufacturer of T&M equipment for the development, operation and maintenance

of quantum computers. Quantum technologies are seen as “the next big thing” and have enormous potential for industry and research. Worldwide development efforts are focusing on quantum computing, quantum cryptography and quantum sensing. The T&M market for quantum computing in particular holds considerable potential for both Rohde&Schwarz and Zurich Instruments, and the two companies are now combining their expertise in this field. Zurich Instruments offers

specialized technology and a strong network in the scientific community, while Rohde&Schwarz is contributing its expertise in RF engineering and its industry contacts. With their complementary products, the two companies will be able to offer fully integrated solutions in the future.



GERMAN CROSS OF MERIT AWARDED TO PROFESSOR ROHDE

Prof. Dr.-Ing. habil. Dr. h.c. mult. Ulrich L. Rohde, son of company founder Dr. Lothar Rohde and a limited partner, has been awarded the Cross of Merit of the Federal Republic of Germany. He was nominated for this prestigious honor by the Bavarian Prime Minister Dr. Markus Söder in recognition of his work as a scientist, professor, developer and entrepreneur in RF and microwave engineering. The laureate, who turned 80 in 2020, holds numerous patents and is the author of more than 350 technical publications and textbooks. He also teaches electrical and microwave engineering at universities in Germany, Romania, India and the USA.

Professor Rohde has been awarded the German Cross of Merit for his work in RF and microwave engineering.



MX AWARD FOR TEISNACH PLANT

The Rohde&Schwarz Teisnach plant in the Bavarian Forest was the overall winner in the MX Award 2020 competition. The MX Award is one of the most important prizes for industrial companies in German-speaking countries. It has been presented annually since 2004 under the patronage of Germany’s Federal Ministry for Economic Affairs and Energy. The motto of the award is “Recognizing strengths, setting standards.” The competition categories include management culture, employee integration, customer orientation, process & product innovation, information technology, quality management, logistics management and network management. The manufacturer that excels in all categories is named the overall winner. The MX Award is the latest in a series of national and European honors received in recent years by the Teisnach plant, the German mechatronics center of the Rohde&Schwarz production network.

Recognition for outstanding performance in all categories: the MX Award.



VIDEO STORAGE PRODUCT LINE EXPANDED WITH BASIC MODEL

Broadcasting and post production studios need very fast storage devices with high reliability and easy scalability. For this Rohde&Schwarz developed the R&S®SpycerNode family, which implements advanced high-performance computing technologies. The family previously consisted of devices from 2 to 5 RU with 12 to 84 drives, which can be clustered to achieve capacities up to the Ebyte range (top and middle in the figure). Now it has been expanded with the R&S®SpycerNode SC model (bottom).

With its market-leading bandwidth of up to 22 Gbyte/s (PCIe 4.0), R&S®SpycerNode SC supports typical high-performance applications such as mastering, editing and color grading at 4K or higher resolution. The 4 RU enclosure can hold up to 960 Tbyte, spread over 60 drives. Several units can be clustered if even more capacity or bandwidth is needed. The ability to trade bandwidth for capacity and utilize 25 percent more storage in endurance mode is unique. This mode also offers constant bandwidth and latency, independently of capacity utilization.

Unlike the top models designed for large storage clusters, which feature not only complete hardware redundancy but also software redundancy through erasure coding (IBM Spectrum Scale™), R&S®SpycerNode SC secures its database with RAID 6.

Helping broadcast studios achieve maximum storage performance:
R&S®SpycerNode (top and middle) and the new R&S®SpycerNode SC.

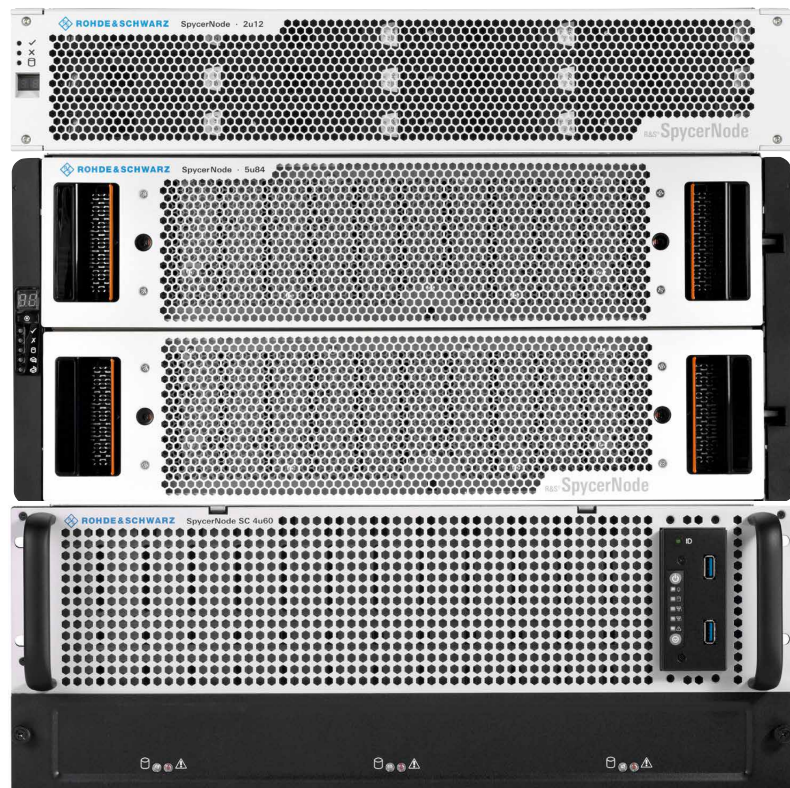

Data integrity is assured even in the event of failure of any two drives – an extremely unlikely event. R&S®SpycerNode and R&S®SpycerNode SC can be operated in any desired mixed configuration and share the general features of the product family, such as management with the convenient device manager, access to all units via a shared name space, and integration into product asset management with R&S®SpycerPAM.

Reference: One of the best-known



US broadcasters with headquarters in New York was looking for a high-throughput

storage solution for fast transfer of news graphics. Their creative staff were constantly confronted with the high-pressure task of editing large video and graphics files from tools such as Flame, C4D, Adobe After Effects, Maya or Premiere and transferring the finished graphic sequences in real time to the receiving studio or playout center. The solution needed to support more than 300 clients and be synchronized over two locations to ensure extremely high reliability (disaster recovery). After an extensive request-for-information process followed by a proof of concept, they opted for R&S®SpycerNode. The customer especially appreciated easy integration of the storage system into the existing complex IT network and its convenient management. After the successful rollout with the news teams, the broadcaster now intends to expand the system to other user groups – first to sports, which will require the deployment of additional R&S®SpycerNode hardware. This is no problem because any desired expansion is possible during operation.

NEW GENERATION OF R&S®ZNB FAMILY

Successful R&S®ZNB network analyzers have been updated

Since their market launch 10 years ago, the network analyzers of the R&S®ZNB family have gained a firm foothold on RF component production lines. Their benefits such as excellent RF performance and ease of operation are also appreciated by many developers. The network analyzers were continuously enhanced over the years and have now been comprehensively revised.

Optimized to meet user requirements: flexible user interface with multitouch display

Keep the proven things. Anyone who is already familiar with the R&S®ZNB or the high-end analyzers of the R&S®ZNA family will quickly feel at home with the new models. Context-sensitive softkey operation, a novel feature in network analyzers at the time, has been further refined, and has now been replaced with a capacitive touch display that can handle dual-touch gestures. Users can zoom in on measurement displays with a spreading gesture in no time. A new control feature adopted from the high-end class is the DUT key – implemented as a hardkey on the R&S®ZNB. It takes the user to a DUT-centric menu where a wizard quickly guides them through the instrument setup required for a specific measurement task.

Stable and robust up to the maximum frequency

The new generation of R&S®ZNB analyzers starts with models up to 4.5 GHz, 8.5 GHz and 20 GHz. All models benefit from a new

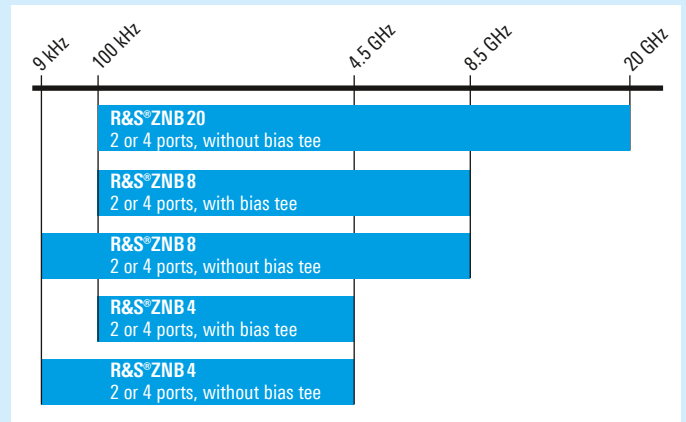

The new R&S®ZNB portfolio starts with models up to 20 GHz. Analyzers with integrated DC power supply via coaxial cable (bias tee via rear plug-in module) have a slightly higher start frequency.

processor platform that provides higher computing power and ensures upgradability of the instruments for years to come. While the RF performance of the models up to 8.5 GHz was left unchanged in line with application requirements, the new RF frontend of the 20 GHz models provides significant improvements. For example, these models deliver output power of typically +13 dBm up to the frequency limit – a feature that is appreciated especially in production. Temperature stability has also been improved – a useful feature given that the analyzers are usually operated continuously in production environments. With a temperature drift of 0.016 dB/K, the analyzers offer performance comparable to that of high-end analyzers. An ESD protection circuit now safeguards the sensitive microwave circuitry of the 20 GHz R&S®ZNB against voltage spikes, thereby increasing robustness. The RF frontend interface (MIPI® RFFE) for controlling DUT frontend modules has been transferred to an external box for all models, allowing it to be placed close to the DUT, which simplifies cabling and setup on the workbench.

With this update, the R&S®ZNB family of network analyzers is optimally prepared to meet the requirements of future generations of RF and microwave products. Further models for higher frequencies will follow.

Tanja Menzel



OTA MEASUREMENTS ON 5G FR2 DEVICES

The R&S®ATS1800C compact test chamber for measurements on 5G wireless devices is now even more versatile. When extended to a multireflector setup, it provides radio resource management tests over the air – and much more.

Reproducible OTA measurements under lab conditions require the use of anechoic test chambers which, depending on the measurement principle employed, can be exceptionally large. A few years ago, OTA measurements were a rare exception and

required specialized, often very large test facilities. Today, they are common laboratory practice due to the extension of 5G into the mmWave range. This calls for compact antenna test ranges (CATR), which do not take up much space. To obtain

accurate results despite the compact size, a highly sophisticated design is required. The DUT must be surrounded by a homogeneous field, which is obtained only at a distance of many meters when plane wave propagation can be assumed between the transmitter and the receiver (direct far field, DFF). In contrast, CATR chambers use parabolic reflectors, which shorten the test setup and collimate the spherical wave from the transmitter into a plane wavefront (indirect far field, IFF). As a result, a quiet zone (QZ) is obtained that fully encloses the DUT at a short distance from the reflector. The larger the quiet zone, the larger the size of the DUT and the greater the flexibility with respect to the DUT's spatial orientation. This plays a significant role in practice because, within certain limits, it does not matter where exactly the antennas are located inside the DUT case (black box approach). This is important because OTA measurements are not only performed by device manufacturers, who of course have this information, but also by service providers and test houses who wish to obtain valid results in a quick and straightforward manner.

With DFF systems, the size of the quiet zone depends on the wavelength and essentially on the distance between the transmit and the receive antenna. With IFF systems, on the other hand, the QZ is primarily determined by the size of the reflector and is largely independent of the chamber size, although certain geometric conditions regarding the distance from the feed antenna to the reflector and



Fig. 1: The R&S®ATS1800C CATR based test chamber is the most compact solution for 5G FR2 OTA measurements.

from the reflector to the DUT antenna have to be met. It is thus possible to generate, in a small space, a cylindrical QZ with a diameter of 30 cm and more, which is sufficient for most wireless devices. Generating a comparable QZ of 30 cm in a DFF system would require a distance of almost 17 m at 28 GHz between the DUT and the test antenna, corresponding to a free space path loss (see box) of 86 dB. Along with the necessary chamber length of roughly 20 m, a DFF system would reduce the dynamic range by approx. 25 dB, or by a factor of 20, compared to an IFF system.

Turned upside down

The advantages of a CATR over a DFF test chamber make it indispensable for mmWave measurements. With a smart design, this concept holds even more options. Conventional chambers have a horizontal setup, with a footprint of at least 1 m x 2.5 m. Rohde&Schwarz chambers, such as the R&S®ATS1800C, need only half the floor space thanks to their vertical design (Fig. 1).

Unlike floor space, equipment height is usually irrelevant in labs as long as it is less than the ceiling height. The R&S®ATS1800C fits through a 2 m standard door and, thanks to its sturdy castors, can be easily moved between labs. Another advantage of a vertical setup is that the DUT just needs to be placed on the test fixture if it is tested in a static position or moving in only one axis. In contrast, with a horizontal setup, it has to be fastened in the quiet zone to resist the force of gravity.

Quiet zone quality critically depends on the reflector quality. The reflectors for the Rohde&Schwarz chambers are milled from an aluminum block with very high precision and come with a gold-plated surface for long-term preservation.

A single chamber for all types of measurements

Anyone investing in a CATR wants to be able to accomplish ideally all necessary OTA measurements with this chamber, whether required by standards or own test concepts. The R&S®ATS1800C offers extension options that open up a broad range of testing capabilities.

For example, products must be able to operate over a wide temperature range if they are to be commercially successful. The R&S®ATS1800C can be equipped with a climatic chamber transparent to RF signals to investigate DUT behavior at temperatures between -40°C and +85°C. The chamber can be fitted and removed at minimum effort.

Relevant standards not only specify mandatory functional tests on wireless devices but also emission limit values, including for out-of-band spurious emissions. The wide frequency range of the R&S®ATS1800C enables emission measurements between 6 GHz and 90 GHz, i.e. up to the second harmonic of an FR2 DUT. Since no single antenna can provide the necessary properties with the required accuracy over such a broad frequency range, the R&S®ATS1800C allows different antennas to be automatically positioned at the focal point of the reflector using a feed switcher with a motor-driven antenna magazine.

An entirely new extension to the R&S®ATS1800C now allows the DUT to be examined when exposed to signals arriving simultaneously at different angles – a typical radio resource management (RRM) test scenario. As in a real network, the wireless device receives signals from multiple base stations at different angles, and its response e.g. to level changes is observed. Handover and roaming scenarios can also be simulated in this

way. In a CATR system, this requires at least one additional reflector. The 3GPP specification defines six different pairs of angles for RRM testing, with relative angular differences from 30° to 150° between the base station signals. With a suitable combination of different reflectors, this requirement can be met with only three additional reflectors. For this purpose, the R&S®ATS1800C can be extended with two side chambers to form the R&S®ATS1800M multireflector system (Fig. 2). This extension is both retrofitable and reversible.

Each side chamber comes with one or two reflectors, plus the associated feed antennas. Same as the reflector

5G frequency ranges FR1, FR2

FR1 more or less covers the previous mobile communications range. The FR2 mmWave range is used with 5G for the first time in mobile communications systems.

Frequency range	Lower frequency limit	Upper frequency limit
FR1	450 MHz	7.125 GHz
FR2	24.25 GHz	52.6 GHz

Far field (Fraunhofer region)

The Fraunhofer formula defines the distance from an antenna of size D at which the propagation of a wave of wavelength λ can be assumed to be planar. This is where the far field starts.

$$r = \frac{2D^2}{\lambda}$$

Free space path loss

In the far field, the path loss of a propagating wave increases with the square of distance and frequency:

$$D_f = \left(\frac{4\pi R}{\lambda} \right)^2$$

In practice, the logarithmic value of this quantity, the free space path loss factor, is used:

$$FSPL = 10 \log_{10} D_f = 20 \log_{10} \left(\frac{4\pi R}{\lambda} \right)$$

WIRELESS

in the main chamber, each additional reflector generates a quiet zone of 30 cm diameter. All quiet zones overlap at the DUT location to form a spherical 30 cm quiet zone, with the advantage that the black box approach can be used without restrictions also for these RRM tests. The large QZ means a significantly lower measurement uncertainty compared to alternative solutions and reliably encloses the DUT in every spatial orientation. The DUT orientation can be changed in fine steps using the 3D positioner so that, while the system uses fixed angles of arrival, the DUT can be set to any absolute angle relative to the base station signals.

This makes the R&S®ATS1800C truly versatile by enabling not only 5G FR2 RF tests but also RRM tests with one or multiple angles of arrival, as well as protocol conformance and demodulation tests – i.e. all measurements that are usually performed conducted at lower frequencies.

Ready to go – out of the box

The R&S®ATS1800C is supplied as a fully assembled and configured unit and can be commissioned on site very quickly. This is also true for the R&S®ATS1800M extension, since both side chambers can be easily attached to the main chamber using latches.

Summary

With mobile communications extending into the mmWave range, over-the-air measurements have become imperative. To perform these measurements at low cost and with little effort, small CATR chambers are needed that support the entire range of tests that could previously, i.e. up to 5G FR1, be performed as conducted tests. The R&S®ATS1800C and its RRM extension R&S®ATS1800M meet these requirements and offer features unique on the market. They combine high measurement accuracy, ease of use and high versatility in a small footprint. They offer all state-of-the-art T&M capabilities required by the mobile communications industry and provide scope to accommodate future requirements.

Günter Pfeifer

Fig. 2: Side chambers attached with latches extend the R&S®ATS1800C base chamber to the R&S®ATS1800M multireflector setup for RRM measurements. A quiet zone of 30 cm in diameter is formed in the area where the beams overlap. Common wireless devices can be conveniently placed in any spatial orientation.

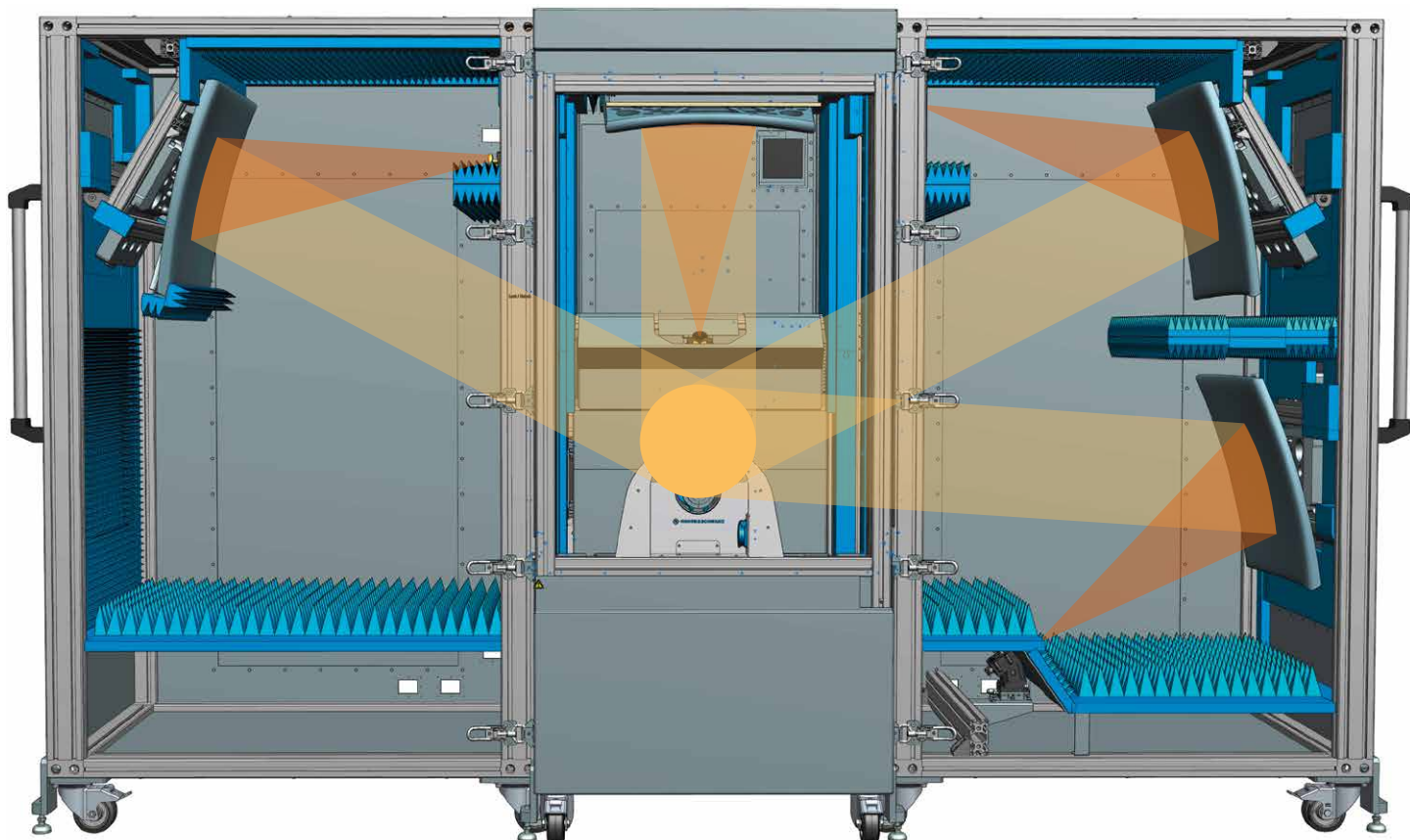

NON-SIGNALING FLAGSHIP



Fig. 1: The R&S®CMP180 radio communication tester is easy to operate thanks to the R&S®CMSquares test environment.

The R&S®CMP180 (Fig. 1) is the new non-signaling allrounder (vector signal generator/signal analyzer single-box tester) among the Rohde&Schwarz mobile communications and wireless testers. With a frequency range from 400 MHz to 8 GHz and 500 MHz bandwidth, it supports legacy standards as well as the latest developments such as Wi-Fi 6E/7 and 5G FR1. The main focus is on mass production testing, but the R&S®CMP180 can

also be used anywhere in the value chain, including engineering validation tests (EVT), design validation tests (DVT) and production validation tests (PVT) (Fig. 3). This makes test results comparable, simplifies software setup, and shortens time to market. Following a one-platform strategy, the R&S®CMP180 is conveniently operated from the R&S®CMSquares test environment which also controls the R&S®CMX500 signaling tester.

Two vector signal generators and signal analyzers that can be connected to eight RF ports each, along with the SmartChannel, DL Broadcasting and Interleaving test features, enable parallel testing with high throughput and maximum flexibility in test configuration. Although conducted tests are common practice in the 5G FR1 frequency range, the R&S®CMP180 delivers enough output power for antenna measurements in a shielded test chamber. Test software for key wireless and cellular standards is initially available. The offering will be quickly expanded to include automotive V2X, GNSS and legacy standards. (Ed.)

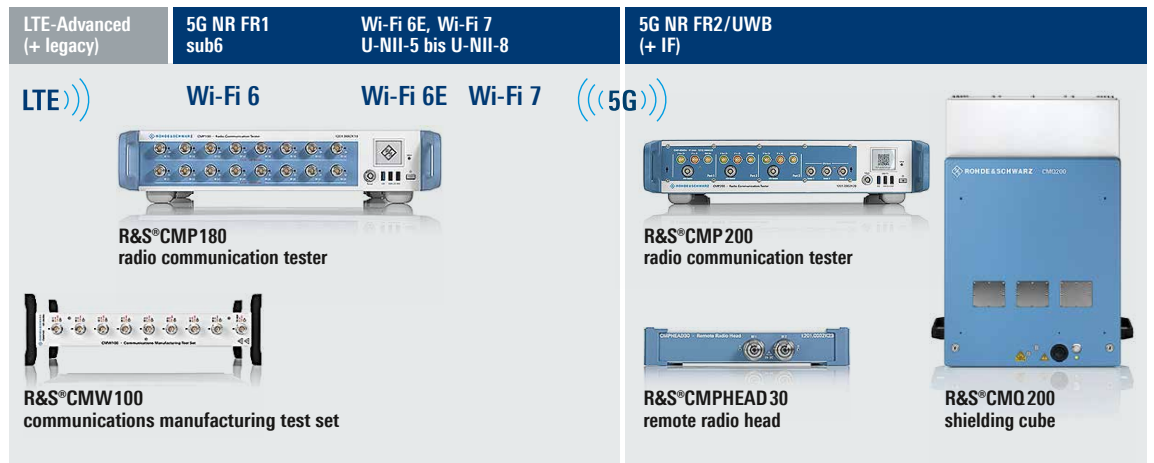
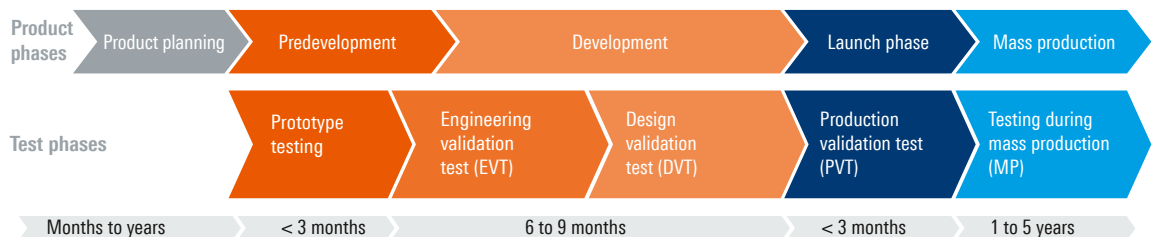
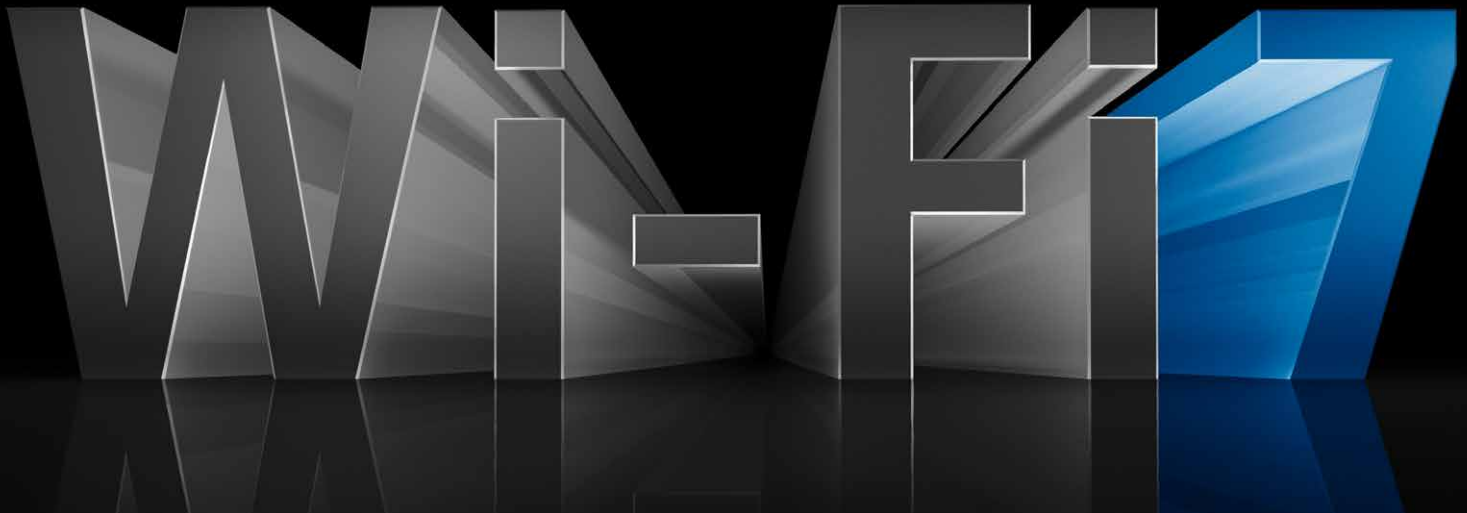

Fig. 2: The R&S®CMP180 rounds out the range of non-signaling testers.

Fig. 3: The R&S®CMP180 can be used throughout the entire development phase, from validation tests up to mass production.





802.11BE SIGNAL GENERATION AND ANALYSIS

The specifications of the next WLAN standard IEEE 802.11be are now definite enough to allow specific implementations to be tackled. Signal generators and signal analyzers open the door to the signal world of Wi-Fi 7.

Development of the next WLAN generation 802.11be (Wi-Fi 7) is in progress. The main development goal is to further increase data throughput compared with to the currently fastest standard 802.11ax (Wi-Fi 6). There are essentially two approaches to this: extension of the modulation schemes, and more flexible use of the allocated frequency spectrum, especially in environments with high user density. 802.11be incorporates both approaches.

The new standard is based on the achievements of 802.11ax, thereby consistently following the same path. For example, the signal bandwidths are increased to 320 MHz, new modulation schemes up to 4096QAM can be used, and parallel transmission of up to 16 data streams is possible. Allocating multiple frequency blocks

(multiple resource units, MRU) to a user allows tailored connection of data-hungry clients to an access point. These extensions collectively lead to Extremely High Throughput (EHT), a designation for 802.11be used in particular in the IEEE specification.

802.11be defines two new protocol formats (PPDU) (Fig. 1): one for multi-user (MU) mode and another for trigger based (TB) mode. Along with EHT-specific fields for control data, each preamble contains some legacy fields to ensure backward compatibility with earlier 802.11 standards. Instruments must be able to handle the new PPDU formats and meet the more demanding physical requirements. Device pairs for generating and analyzing 802.11be signals are presented below.

Fig. 1: 802.11be protocol formats (PPDU)
(green: legacy fields;
blue: EHT-specific fields).

Multi-user PPDU

L-STF	L-LTF	L-SIG	RL-SIG	U-SIG	EHT-SIG	EHT-STF	EHT-LTF	EHT data	PE
-------	-------	-------	--------	-------	---------	---------	---------	----------	----

Trigger based PPDU

L-STF	L-LTF	L-SIG	RL-SIG	U-SIG	EHT-STF	EHT-LTF	EHT data	PE
-------	-------	-------	--------	-------	---------	---------	----------	----

Generating 802.11be signals

An 802.11be signal generation solution must fulfill two conditions: support for 320 MHz signal bandwidth to allow the use of all EHT transmission modes, and the ability to generate 4096QAM signals in the 6 GHz band (5.925 GHz to 7.125 GHz). The EVM performance must also be below -50 dB for testing power amplifiers and receivers. The R&S®SMW200A (top end) and R&S®SMM100A (midrange) vector signal generators meet all of these requirements.

Two software options with identical functions are needed for both instrument series: R&S®Sxx-K54 is the WLAN base option. It enables signal generation compliant with 802.11a/b/g/n/j/p. The additional option R&S®Sxx-K147 extends this with new features for 802.11be.

Quick PPDU configuration

Only a few steps are needed to configure 802.11be signals. In the first step, the transmission mode is selected in the frame block sequencer (Fig. 2), and then the PPDU is configured. As previously mentioned, 802.11be introduces new PPDU formats (EHT MU and EHT TRIG), which in addition to legacy training and signaling fields contain U-SIG and EHT-SIG fields specific to 802.11be signaling (Fig. 1). Some of this signaling data, e.g. PHY version identifier, is preconfigured. Other parameters, such as link direction, PPDU type, BSS color, STA-ID, MCS type and channel coding, can be directly and clearly selected in the PPDU configuration dialog (Fig. 3).

The menu-driven settings for RU allocation and punctured channel are applied indirectly to EHT-SIG and U-SIG (Fig. 4). As provided by the standard, the 802.11be option allows multiple resource units to be allocated to an individual user. The RU size determines which RUs, consisting for example of 242, 484 or 996 subcarriers, and how many of them can be allocated to a user. The MRU index defines the position of the RUs that are used. This way, specific frequency ranges within the signal bandwidth, which might be occupied by privileged applications (e.g. weather radar), are automatically punctured (excluded) and therefore not used for transmissions.

Spatial mapping

To further increase data throughput, the 802.11be standard specifies up to 16 parallel data streams for both SU MIMO (16×16) and MU MIMO and additionally addresses up to eight stations simultaneously, with up to four data streams available for a user in this case. R&S®SMW200A and R&S®SMM100A calculate all data streams with onboard resources, although at most two can be output simultaneously over RF interfaces (with suitable hardware).

Fig. 2: WLAN configuration with the R&S®Sxx-K54 option. After selecting the standard (first column), further settings can be carried out via the configuration menu (third column from right) (Figs. 3 and 4).

Std.	Type	Physical Mode	Tx Mode	Frames	Idle Time /ms	Data	DList / Pattern	Boost /dB	PPDU	Data Rate /Mbps	State
11be	Data	Mixed Mode	EHT-20MHz	1	0.100	A-MPDU		0.00	Conf...		On
11n	Data	Mixed Mode	HT-20MHz	1	0.100	PN 9		0.00	Conf...	13.00	On
11be	Data	Mixed Mode	EHT-320MHz	1	0.100	A-MPDU		0.00	Conf...		On
11ax	Data	Mixed Mode	HE-20MHz	1	0.100	A-MPDU		0.00	Conf...		On
11ac	Data	Mixed Mode	VHT-20MHz	1	0.100	A-MPDU	Conf...	0.00	Conf...	13.00	On

Fig. 3: Configuration of the protocol fields (PPDU).

Parameter	Value	Category
Link Direction	Downlink	Stream Settings
Guard	0.8us	EHT General
Max PE Duration	0us	Additional EHT-U-SIG
OFDMA Mode	<input type="checkbox"/>	Logging
Time Domain Windowing Active	<input type="checkbox"/>	

Fig. 4: MRU configuration for a 320 MHz channel.

STA Id	Nsts	RU Size	MRU Index	MU MIMO	Gain /dB	TxBF	PPDU	State
User 1	1	3x996+484	7	Off	0.00	Off	Config...	On

Analyzing 802.11be signals

The new R&S®FSW-K91BE measurement application adds 802.11be capability to the existing WLAN signal analysis capabilities (802.11 a/b/g/n/p/ac/ad/ax/ay) of the R&S®FSW signal and spectrum analyzer. There are two approaches for analysis:

1. The PPDU format configuration menu allows to define signals that do not fully comply with the standard. Fig. 5 shows an example for resource unit definition.
2. A more convenient approach is to use the auto demodulation and auto detection modes to configure parameters such as the length of the EHT long training field (EHT LTF) and guard interval. The allocation of resource units as well as the modulation and coding scheme (MCS) and other user-specific values is also possible as defined in the new signal fields U-SIG (universal) and EHT-SIG (Fig. 6).

Fig. 5: Manual allocation of resource units and user-specific indices.

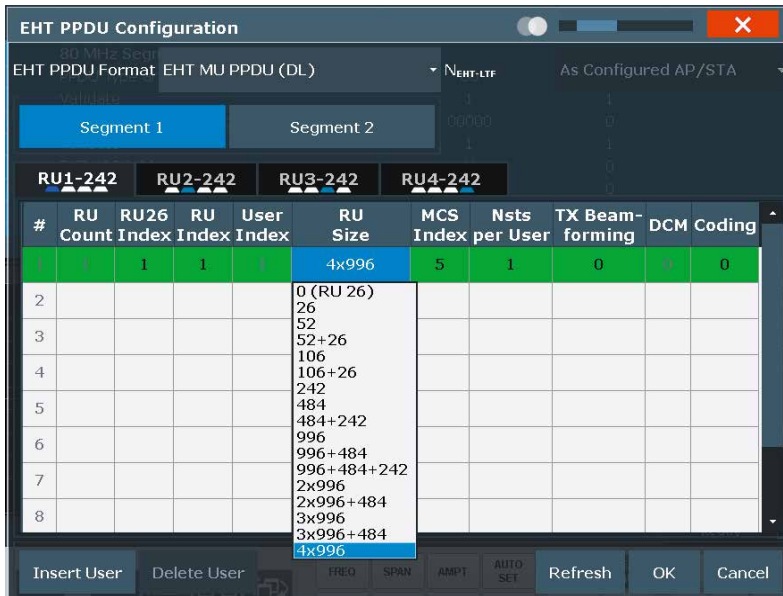

Fig. 6: In auto detection mode, the analyzer automatically configures itself for an applied 802.11be signal and lists its parameters.



Two new 4096QAM modulation and coding schemes, as well as signal bandwidths up to 320 MHz, place higher demands on signal quality than in the past. The 802.11be D0.2 standard requires a maximum EVM of -38 dB. Allowing for a safety margin of 10 dB, the analyzer should typically be able to measure the EVM accurately down to at least -48 dB. Equipped with the R&S®FSW-B320 option for 320 MHz analysis bandwidth, the R&S®FSW achieves values < -50 dB, ensuring enough margin for chip development in particular.

Along with the usual settings for channel estimation, the R&S®FSW-K91BE measurement application enables adjustment of parameters such as phase, timing and level as well as compensation for I/Q mismatches. The measurement displays and tables for the presentation of constellation diagrams, measurement results, signaling field content and other data can be arranged as needed (Fig. 7).

For applications where speed is a primary consideration, for example on production lines, the R&S®FSVA3007 signal and spectrum analyzer with its frequency range up to 7.5 GHz and analysis bandwidth of 400 MHz (R&S®FSV3-B400 option) is the ideal instrument for 802.11be measurements. Along with the WLAN base measurement option, this requires the R&S®FSV3-K91BE option, which is functionally equivalent to the R&S®FSW-K91BE described above.

Werner Dürport, Michael Kaltenbach

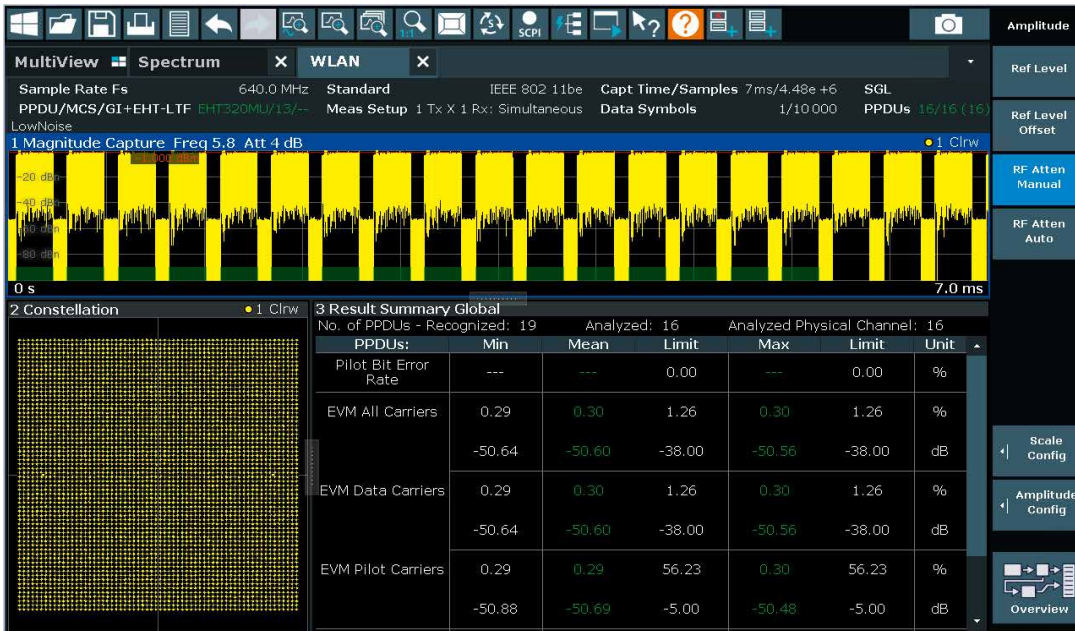

Abbreviations

BSS	Basic service set
EHT	Extremely High Throughput
L	Legacy
LTF	Long training field
MCS	Modulation and coding scheme
MRU	Multiple resource unit
MU	Multi-user
PPDU	Protocol packet data unit
PHY	Physical layer
RU	Resource unit
PE	Packet extension
RL	Repeated legacy
SIG	Signal field
STA	Station (mobile device)
STF	Short training field
SU	Single user
TB	Trigger based
U	Universal

Fig. 7: Analysis of an 802.11be signal with the R&S®FSW-K91BE option.

Generators and analyzers for IEEE 802.11be and their required options



R&S®SMW 200A high-end vector signal generator

- ▶ R&S®SMW-B1007 Output frequencies up to 7.5 GHz
- ▶ R&S®SMW-B13XT Broadband baseband module
- ▶ R&S®SMW-B9 Broadband baseband generator (500 MHz BW)
- ▶ R&S®SMW-B711 Improved phase noise
- ▶ R&S®SMW-K54 IEEE 802.11 base options including 11a/b/g/n/j/p
- ▶ R&S®SMW-K147 IEEE 802.11be



R&S®SMM 100A midrange vector signal generator

- ▶ R&S®SMM-B1007 Output frequencies up to 7.5 GHz
- ▶ R&S®SMM-B9 Baseband generator (120 MHz BW)
- ▶ R&S®SMM-K523 Bandwidth extension to 240 MHz
- ▶ R&S®SMM-K524 Bandwidth extension to 500 MHz
- ▶ R&S®SMM-K520 Real-time extension
- ▶ R&S®SMM-K54 IEEE 802.11 base options including 11a/b/g/n/j/p
- ▶ R&S®SMM-K147 IEEE 802.11be



R&S®FSW 26 high-end signal and spectrum analyzer

- ▶ R&S®FSW 26 Signal and spectrum analyzer up to 26.5 GHz
- ▶ R&S®FSW-B320 Bandwidth extension to 320 MHz
- ▶ R&S®FSW-B24 RF preamplifier
- ▶ R&S®FSW-K91 IEEE 802.11 base options
- ▶ R&S®FSW-K91BE IEEE 802.11be



R&S®FSVA 3007 midrange signal and spectrum analyzer

- ▶ R&S®FSVA 3007 Signal and spectrum analyzer up to 7.5 GHz
- ▶ R&S®FSV 3-B114 Higher processing power
- ▶ R&S®FSV 3-B 400 Bandwidth extension to 400 MHz
- ▶ R&S®FSV 3-B24 RF preamplifier
- ▶ R&S®FSV 3-K91 IEEE 802.11 base option
- ▶ R&S®FSV 3-K91BE IEEE 802.11be

RUSH HOUR ON THE TEST BENCH

Increasing autonomy and ever more sophisticated safety functions are leading to a rising number of sensors installed in vehicles. A new pair of instruments makes testing of onboard radars a routine exercise.





Many drivers like the convenience of adaptive cruise control and appreciate the benefits of collision warning systems. These advanced driver assistance systems (ADAS) get their environment data from radar sensors, which are being installed in ever-increasing numbers all over vehicles (Fig. 1). As security-related components, they must function flawlessly at all times and fully conform to specified performance data. Up to now this has not been easy to prove, despite the availability of radar echo generators that can be used to simulate simple sample scenarios. The development is heading toward autonomous driving, and the situations that must be handled reliably by onboard electronics are becoming more and more demanding. Ultimately, the technology must fully replicate the cognitive abilities of a human driver. However, vehicle AI can only make trustworthy decisions if the underlying sensor data reflects the actual environment with the complexity and precision required for vehicle operation. This means that objects of different sizes, located at different distances and moving at different speeds, as typically found in urban situations (e.g. at pedestrian crossings or intersections), must be captured with sufficient reliability.

Fig. 1: Short-range and long-range radars provide environment data for various driver assistance systems.

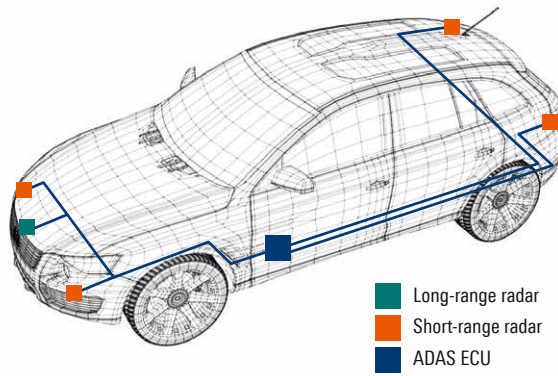

Only a tested radar is a safe radar

The required quality assurance of automotive radars includes acceptance measurement of each sensor on manufacturer production lines as well as type testing of the vehicles ready for series production in which the sensors are integrated. Testing is also required earlier in the development process for sensors, ADAS and vehicles, where maximum test setup flexibility is particularly needed.

Testing of individual sensors is best performed in shielded test chambers, such as the R&S®ATS1500C, because test conditions can be accurately reproduced and uncontrolled external influences can be eliminated. Entire vehicles must be measured on a chassis dynamometer under semi-realistic operating conditions. Up to now, only the vehicle could be tested under realistic conditions, and realistic scenarios for radar tests were only rudimentarily implemented. In

particular, simulation of tangential motion was only possible with mechanically moved antennas or antenna configurations with large gaps, yielding unsatisfactory results. Now a new system solution for testing automotive radars brings the diversity of real street scenarios into the test environment.

The key to the radar test system, consisting of the R&S®AREG800A radar echo generator and the R&S®QAT100 advanced antenna array (Fig. 2), is purely electronic operation. The generator simulates the targets with the desired size (radar cross section), distance and speed, while the antenna array first receives the radar pulses and feeds them to the echo generator, and then returns the echoes at the desired angle or causes them to move in small steps over an angular range corresponding to the tangential speed of the simulated objects. Both instruments can be cascaded to create test situations of virtually any desired complexity. It is even possible to achieve 360-degree azimuth coverage and height profiles.

Small-scale and large-scale modularity

The system can be configured precisely for specific test requirements. The instruments themselves can be equipped with options for different scenarios. In the minimal configuration with one baseband module, the R&S®AREG800A simulates a single dynamic target. Four modules can be fitted to simulate up to eight targets when the R&S®AREG800A is operated with the R&S®QAT100 as a frontend.

Fig. 2: The R&S®AREG800A radar echo generator and its RF frontend, the R&S®QAT100 advanced antenna array (right), along with R&S®AREG millimeterwave remote frontends (small modules). Virtually any type of radar test system can be setup with these three components.



Because of the signal processing time, digital echo generators have a certain latency that takes the form of a blind zone or minimum target distance. With the R&S®AREG800A, the distance is nearly 17 m. For short-range scenarios, such as testing emergency braking assistance systems, graduated analog delay lines for distances to below 4 m can be added. The radar does not notice the transition from digital to analog delay.

High-resolution azimuth range

The R&S®QAT100 advanced antenna array is an innovative RF frontend for the R&S®AREG800A. It processes radar signals with up to 4 GHz bandwidth in the frequency range from 76 GHz to 81 GHz. In the base configuration, an instrument contains 96 transmit antennas arranged in a row with a spacing of 3.7 mm, internally divided into four arrays. The R&S®AREG800A can feed a separate echo to each array (Fig. 3). For a target without a tangential motion component, the echo is emitted by a single, arbitrarily selectable antenna, but for a target moving tangentially the echo travels along the row. The four antenna arrays of a row can also be coupled to use the full width of the instrument for broad target motions. The previously described configuration can optionally be doubled, giving the R&S®QAT100 a total of 192 transmit antennas in two rows with eight arrays for simultaneous simulation of up to eight targets.

Conventional frontends also possible

For tests that do not require the flexibility of the R&S®QAT100, such as scenarios without tangential motion or measurements in a test chamber, up to four R&S®AREG millimeterwave remote frontends can be used with the R&S®AREG800A instead of the R&S®QAT100 (Fig. 2). Each of these frontends can emit up to eight echoes in a fixed direction in response to a radar signal. This can be necessary to simulate a set of targets at different distances, such as pedestrians or cyclists in front of a truck. Up to 32 targets in total can be simulated with this setup.

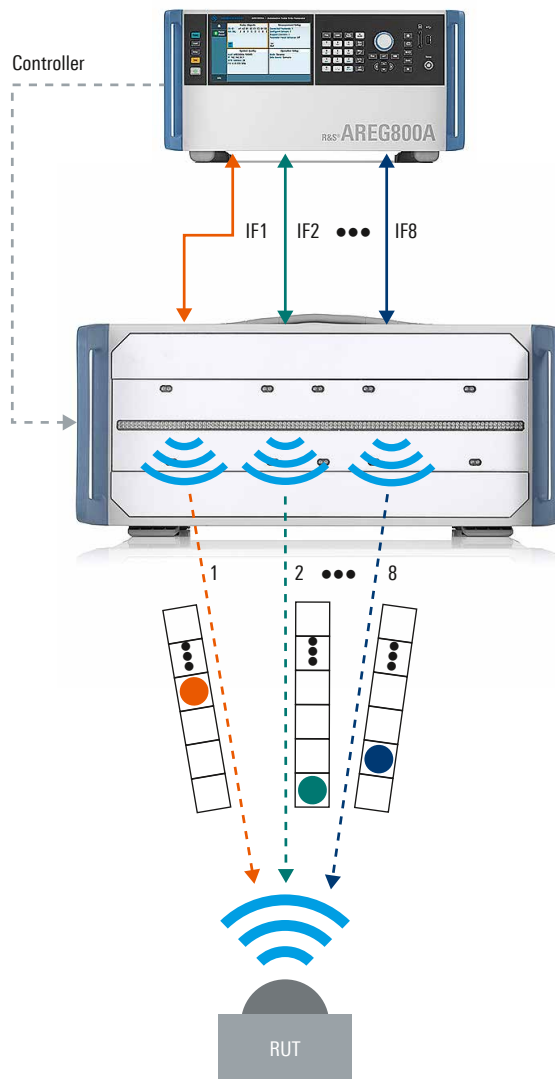

Fig. 3: In combination with the R&S®QAT100, the R&S®AREG800A can simultaneously simulate eight targets using freely definable 4D data (direction, distance, size, speed) within the system limits and send their echoes back to the radar. With suitable configuration, a target can be moved in fine steps over the entire angle range of an antenna row. The front of the R&S®QAT100 is covered with stealth material so it does not appear as a radar target.



Fig. 4: The R&S®QAT-Z50 shielding system allows the R&S®QAT100 to be used in a normal lab environment. The radar sensor is mounted at the opposite end.

New: live scenarios in VIL test setups

For testing individual radar sensors in development or production, Rohde&Schwarz provides compact shielded chambers such as the previously mentioned R&S®ATS1500C or – specially developed for the R&S®QAT100 – the R&S®QAT-Z50 mini shielded chamber for the lab bench (Fig. 4).

Testing the radar functionality of an entire vehicle is naturally a lot more complicated. For this, a large RF shielded test chamber with a chassis dynamometer is needed (Fig. 5). Complete system tests, however, were previously only possible to a limited extent due to the lack of suitable over-the-air test equipment. Instead, the ADAS control unit was usually fed with simulated sensor data (Fig. 6, top). This required accurate acquisition of the environment by the sensors. The new R&S test system includes the radar sensors in the test (radar in the loop, Fig. 6, bottom), allowing real data to be used. An arc-shaped radar-reflecting wall of cascaded R&S®QAT100 units is set up in front of the chassis

dynamometer. The number of units depends on the desired angular coverage and angular resolution. The number of R&S®AREG800A digital backends required depends on the complexity of the scenarios to be simulated. A fully equipped R&S®AREG800A simulates up to eight targets that can be distributed to up to eight R&S®QAT100 units. Individual targets can be transmitted over the entire R&S®QAT100 chain, i.e. across a broad azimuth range. For very dense scenarios, each R&S®QAT100 uses an R&S®AREG800A of its own (Fig. 7).

Sometimes it is necessary to simulate situations in which a target moves not only in a plane, but also in height. An overpass approach road is a typical scenario. For such cases, the R&S®QAT100 can be tipped 90 degrees and operated lying on its side.

Summary

Many driver assistance systems, and in particular growing vehicle autonomy, depend on the reliable operation of more and more installed

Fig. 5: The R&S®AREG800A and R&S®QAT100 enable realistic radar tests on a chassis dynamometer using virtual scenarios of almost any complexity.

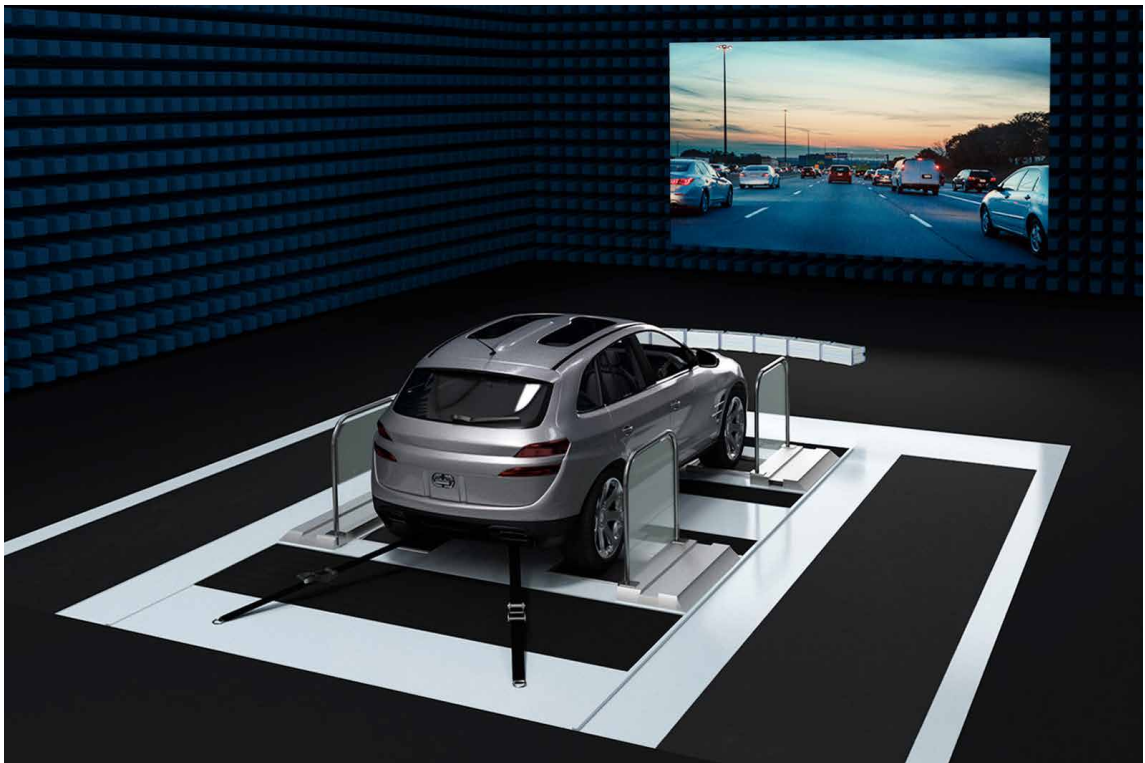

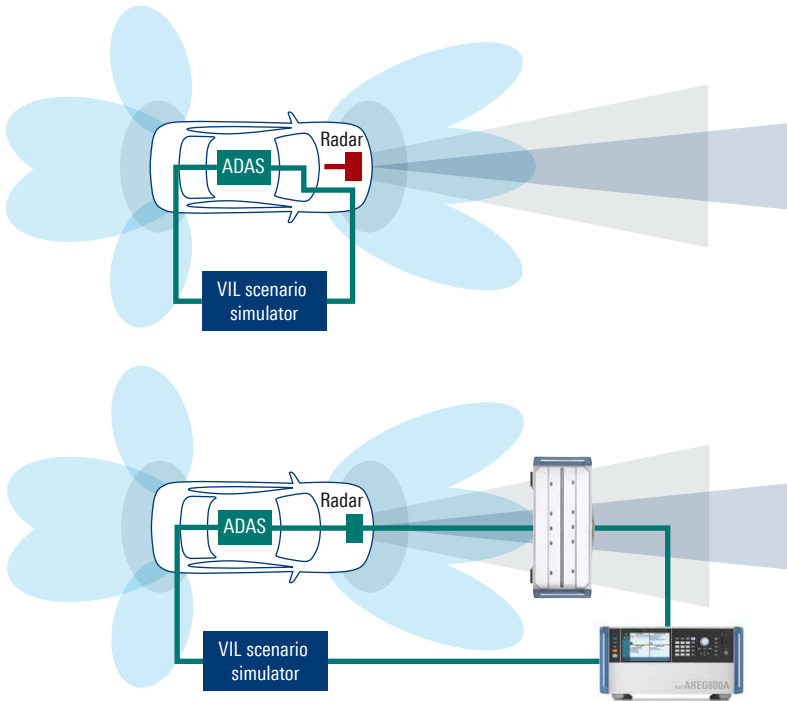

Fig. 6: In the past, radar based ADAS were mainly tested in vehicle-in-the-loop setups using simulated scenarios with the radar sensors out of the loop (top). The target data was provided by a scenario simulator. The R&S®AREG800A and R&S®QAT100 allow the radar sensors to be included in the test loop (radar in the loop).

radar sensors. Previously only rudimentary testing of these sensors was possible. The new radar test system, consisting of an R&S®AREG800A radar echo generator and an R&S®QAT100 advanced antenna array, remedies this. Radar test environments with virtually any desired complexity can be set up with this modular system. It can be used along the entire development and validation path of sensors and radar based ADAS, including vehicle-in-the-loop tests of complete vehicles on a chassis dynamometer. As a result, the system makes an important contribution to the safety of future vehicle generations.

(Ed.)

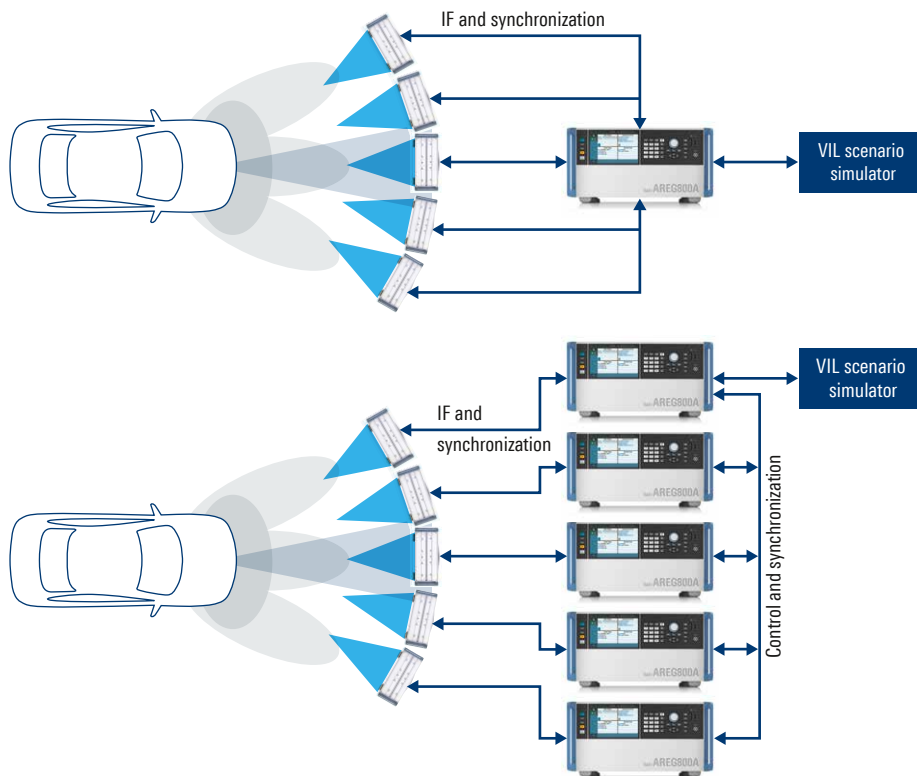

Fig. 7: The number of necessary R&S®AREG800A and R&S®QAT100 units depends on the number of targets and their spatial density, as well as the angular range to be covered.

YOUR PARTNER FOR AUTOMOTIVE ETHERNET

Automotive Ethernet covers a family of standards that have been developed to adapt Ethernet technology to the requirements of vehicle connectivity. The latest MultiGBASE-T1 version is especially powerful and challenging, but it can be reliably implemented in market-ready products using an automatic test solution.

Automotive Ethernet has become the de facto standard for vehicle connectivity. Since its breakthrough with BroadR-Reach® technology, this robust, lightweight and compact standard enables the transmission of large data volumes at up to 100 Mbit/s from sensors to control units in line with automotive EMC standards.

Current trends such as autonomous driving, active advanced driver assistance systems (ADAS) and telematics services, however, require significantly faster transmission technologies. Enormous amounts of data from a growing number of sensors and high resolution cameras must be transmitted from various places in the vehicle. Safety critical technologies like active ADAS and vehicle to everything (V2X) additionally require low latencies for real-time communications. Greater bandwidths are also needed to pave the way for onboard networks with a zonal architecture. This is possible by enabling fast

connection of local domain controllers to a backbone.

A new standard for future onboard networks

MultiGBASE-T1, as the next evolutionary step of automotive Ethernet, has been developed to meet these rising performance requirements. It is fully based on IEEE 802.3ch, specifies three speed levels (2.5 Gbit/s, 5 Gbit/s and 10 Gbit/s), and operates in full duplex mode. It supports autonegotiation (independent negotiation of transmission conditions), and is therefore completely backward compatible.

Unlike 100BASE-T1 and 1000BASE-T1, the new multi-gigabit standard utilizes PAM4 modulation with four discrete voltage levels and symbol rates of 1.4 Gsym/s, 2.8 Gsym/s, or 5.6 Gsym/s (Fig. 2). It also requires shielded twisted pair (STP) cables, unlike its slower predecessors that could manage with unshielded twisted pair (UTP) cables.

The IEEE published the new standard at the end of June last year, and the first chips and interfaces (PHY) are already on the market. MultiGBASE-T1 interoperability and compliance testing are being addressed by the new tech committee TC15 of the Open Alliance Special Interest Group, which is dedicated to the promotion of Ethernet based communications in the automotive sector. The Physical Media Attachment (PMA) specification is now in the development stage, with the strong participation of Rohde&Schwarz as a member of the tech committee.

Automated compliance test solution

Control units and chipsets must fulfill the PMA transmitter test specification to demonstrate compliance with the standard. For this, Rohde&Schwarz offers a fully automatic test solution with the new R&S®RTx-K88 options for the R&S®RTO and R&S®RTP oscilloscopes (Fig. 1). The R&S®RTP is suitable for testing data rates up



Fig. 1: The R&S®RTP164 oscilloscope with 16 GHz bandwidth – shown here connected to an automotive domain controller – is suitable for compliance tests of all transmission rates specified in MultiGBASE-T1.

	10BASE-T1S	100BASE-T1S	1000BASE-T1S	MultiGBASE-T1
IEEE standard	802.3cg	802.3bw	802.3bp	802.3ch
Data rate	10 Mbit/s	100 Mbit/s	1 Gbit/s	2.5 / 5 / 10 Gbit/s
Symbol rate	12.5 Msymb/s	66.66 Msymb/s	750 Msymb/s	1.4 / 2.8 / 5.6 Gsymb/s
Coding	4B 7 5B, DME	PAM3	PAM3	PAM4

Fig. 2: Comparison of automotive Ethernet standards.

Fig. 4: The R&S®RT-ZF7A test adapter is suitable for all MultiGBASE-T1 test cases.

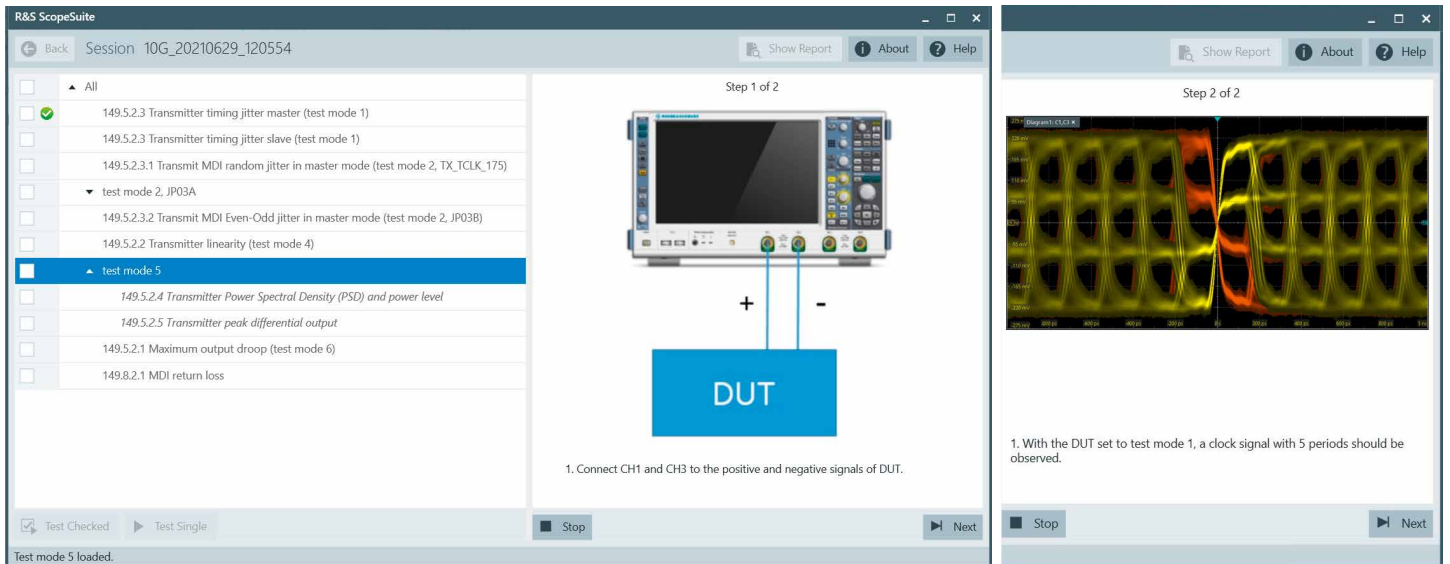

Fig. 3: R&S®ScopeSuite with the R&S®RTx-K88 option conveniently guides users through the compliance test suite for MultiGBASE-T1 chips and control units.

to 10 Gbit/s, which covers all rates specified in the standard, while the R&S®RTO is suitable for data rates up to 2.5 Gbit/s. The solution supports all transmitter tests defined in IEEE 802.3ch, such as jitter, transmitter linearity, output droop, etc. The test solution also includes the R&S®ZND or R&S®ZNB vector network analyzer for MDI return loss measurements.

The solution is built around the R&S®ScopeSuite test software (Fig. 3), which controls the devices, configures them for the respective tests and calculates the results. A test wizard guides users through the process step by step with illustrated instructions. References to the IEEE PMA specification and the test modes to be set up are clearly marked to support users.

The result of each test case is shown by a pass/fail indicator. Configurable test reports deliver detailed background information with all measurement results and screenshots relevant to the test case. Users can insert company-specific logos and export reports in different file formats, such as PDF or DOC. The ScopeSuite software runs directly on the oscilloscope or on a separate PC.

No test solution would be complete without reliable contacting of the DUT. The R&S®RT-ZF7A adapter provides the transition from the twisted pair cable to SMA coaxial connectors, ensuring precise signal sampling without expensive differential probes (Fig. 4). Solder pads allow users to attach their favorite connectors to optimize signal integrity.

Summary

Nearly all new vehicles are using Ethernet based data connections in their onboard network. The new MultiGBASE-T1 variant is designed for low latency, high data rate applications, which are increasingly common on the way to greater vehicle autonomy, for active driver assistance systems and for V2X connectivity. The compliance test solution based on the R&S®RTO or R&S®RTP oscilloscope automatically processes all specified test cases, incorporates network analyzers, and includes versatile and economical test adapters to ensure fast and optimal measurement results.

Jithu Abraham

GENERATION LEAP

About 10 years ago, Rohde & Schwarz surprised the professional world with its first digital oscilloscope, the R&S®RTO. In the meantime, the instrument has been completely renewed and updated, providing users with an all-new and redesigned R&S®RTO6.

The R&S®RTO6 has been enhanced with significant improvements in response to extensive customer feedback for the previous models. The new "best of midrange" instrument comes with an updated user interface, a larger display, excellent specifications and a comprehensive range of software options, providing fast, detailed insights into all types of electronic circuits better than ever.

Quick and easy measurement results

Operational efficiency in everyday measurements was a key focus in development. The most striking enhancements are a large 15.6" touch display and a new user interface. Its design successfully balances the conflicting requirements of a maximized, unobstructed viewing area for the measurements and constant access to control elements and desired functions without users having to work their way through deep menu trees. Users can arrange results on the

screen as desired, using the tried and tested R&S®SmartGrid function already available in the previous model. Screenshots with the most recent oscilloscope displays can be stored as savesets and easily identified and recalled later on.

Excellent specifications for in-depth signal information

The R&S®RTO6 is based on the previous R&S®RTO series. Its key figures include a maximum bandwidth of 6 GHz, a sampling rate of 20 Gsample/s, and an unri-

valued acquisition rate of up to one million waveforms per second, enabling reliable detection even of sporadic signal anomalies. Low-noise components and a highly linear A/D converter result in excellent signal integrity and up to 9.4 effective number of bits (ENOB). The unique high definition mode uses a digital filter to increase the vertical resolution to up to 16 bit, enabling very precise measurements with low noise. The patented digital trigger with adjustable hysteresis can fully utilize this high resolution to isolate even the smallest signal details.

Numerous measurement functions for a thousand and one applications

The R&S®RTO6 is a universal instrument with a wealth of functions, which can be further expanded with software options to support many special applications. The zone trigger is an effective tool. Users can easily define trigger zones in both the time and the frequency domain by drawing them with their finger on the touchscreen. In the same way, users can set up mask tests with simple touch gestures for signal error detection with defined tolerance limits.

Software based applications include automated compliance testing of high speed interfaces including jitter and noise analysis, decoding of serial protocols, measurement functions for power electronics, and high-performance spectrum analysis (FFT), which supports users especially with EMI debugging. All measurement functions come preinstalled and can be enabled via keycode at any time. An extensive probe portfolio, which can also be used with other Rohde&Schwarz oscilloscopes, is available for contacting the DUTs. As with the previous R&S®RTO, the R&S®RTO6 has been optimized for maximum user convenience. A key factor for all-day stress-free lab use is quiet operation. The barely audible R&S®RTO6 fulfills all expectations also in this regard.

Dr. Tim Paasch-Colberg



GENERAL PURPOSE

Made by users for users: Numerous customer demands were taken into account when designing the R&S®RTO 6 to achieve maximum user ergonomics.



Users profit from a large-area measurement display and at the same time can quickly access all functions through a compact main menu and multiple toolbars.



Four channels, two domains: It is often helpful to correlate the time and frequency behavior of a DUT. The R&S®RTO 6 displays the DUT's time and frequency response for multiple channels simultaneously.



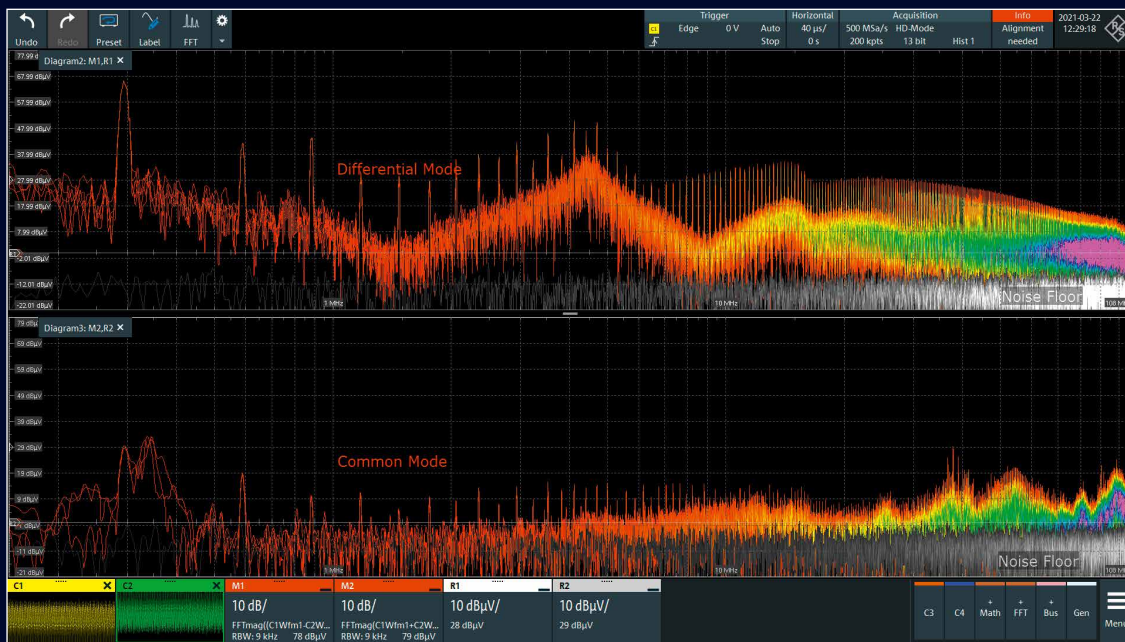

The FFT spectrum analysis function demonstrates its capability when measuring EMI such as conducted disturbance shown here.



Specialized software options are available to analyze Ethernet signals such as 1000BASE-T1.

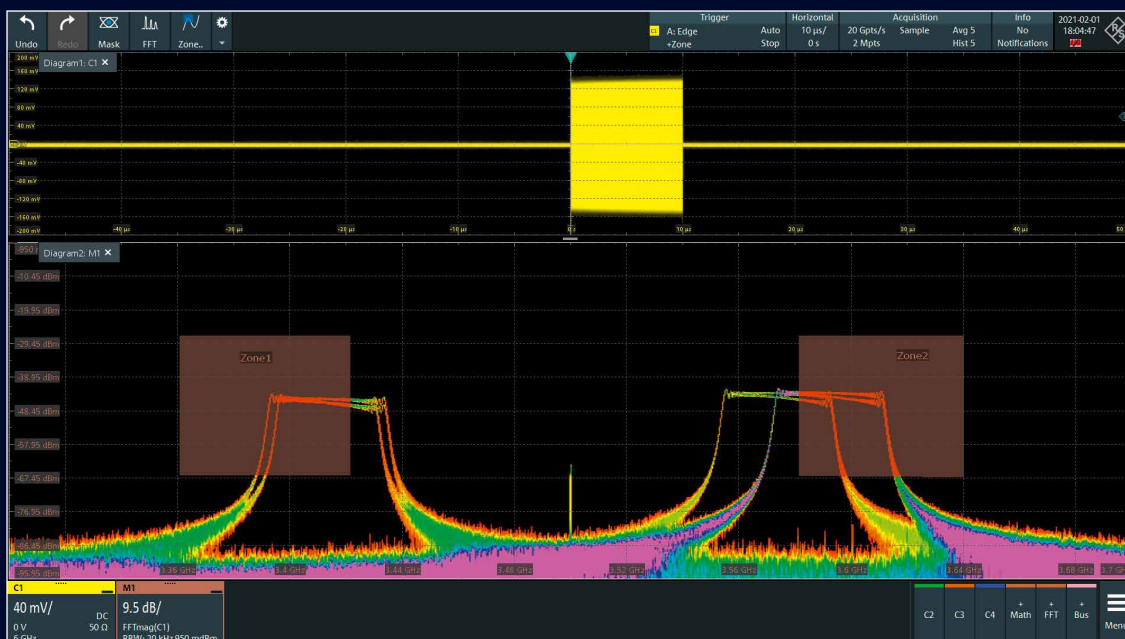

The zone trigger lets users define up to eight trigger zones in both the time and the frequency domain and logically combine them using math functions – even over multiple channels.

CONFORMANCE TEST FAILED. WHAT NOW?

Root cause analysis of signal integrity problems on high speed digital buses

Conformance tests are performed on serial data interfaces such as USB, HDMI and PCI Express to ensure interoperability between electronic devices and accessories. In cases where signal integrity problems are encountered, the R&S®RTP oscilloscope supports root cause analysis by providing powerful tools such as eye diagrams, jitter and noise separation as well as time domain reflectometry.

Automatic conformance tests for high speed data interfaces

Conformance tests represent an important milestone during product development. The relevant standardization committees have published

detailed test specifications for many interfaces such as USB and Ethernet. Specialized test labs offer complete testing services for such interfaces, including documentation and certification. For users who need to perform these tests on their own, the

R&S®RTP provides automated test solutions for all common interface standards. These solutions are equipped with graphical measurement configuration tools and off-shelf test sequences. No matter how the testing is performed: If results do not

Fig. 1: Conformance test for USB 3.2 Gen 1 with the R&S®RTP164 oscilloscope (16 GHz).



Fig. 2: Acquisition of the “short channel” trace for a USB 3.2 Gen 1 device on channels 1 and 3 with real-time calculation as a differential signal (Diff 1). Calculation of the “long channel” signal through embedding of the S-parameters from the USB-IF (Math 1).

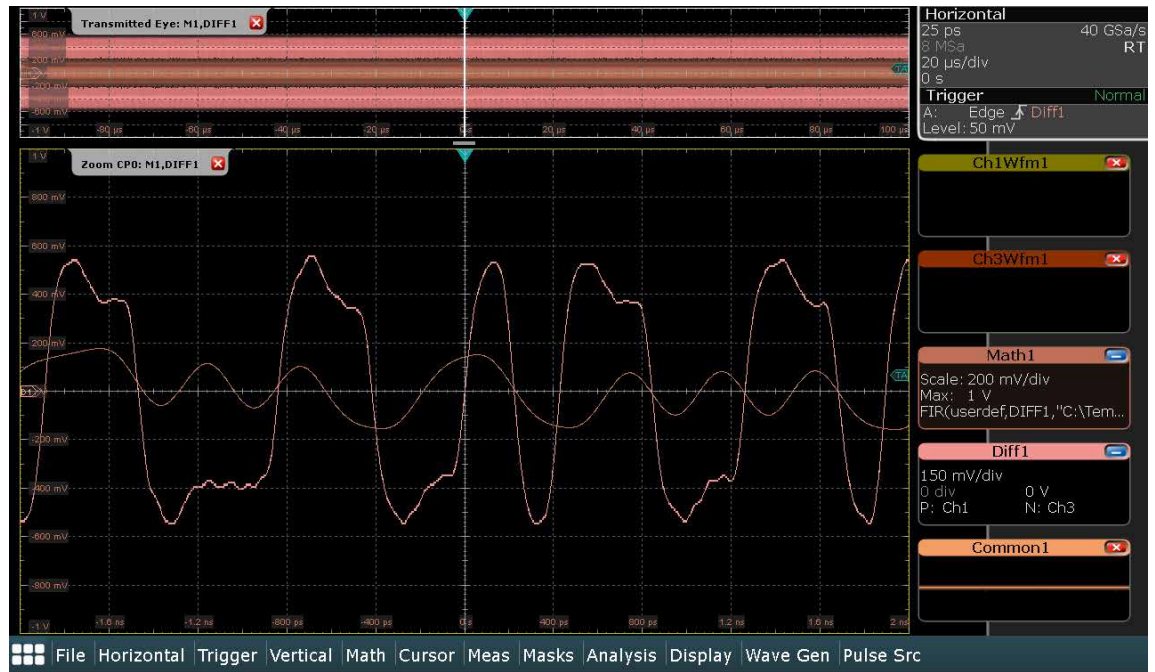

comply with the standard, time-consuming debugging is required.

During root cause analysis, the R&S®RTP oscilloscope provides support with analysis tools such as eye diagrams with mask tests or separation of jitter and noise components. Time domain reflectometry is also available for verifying the transmission characteristics of passive signal path components such as connectors, cables and signal lines on the printed board.

Conformance testing for USB 3.2 transmitters

USB 3.2 transmitter conformance testing focuses on the eye diagram (transmitted eye) for verifying the eye opening, signal levels and jitter components. This test is performed directly on the device output (short channel) as well as with a simulated signal path (long channel). For long channel tests, the USB Implementers Forum (USB-IF) has published files with S-parameters for various cable and signal trace lengths. During

the tests, the oscilloscope acquires clock and data signal sequences with a length of 200 μ s. These sequences are then checked for compliance with the standard using the SigTest USB-IF analysis software. Depending on the test mode, each USB device must generate the compliance patterns on its own: For USB 3.2 Gen 1, this means patterns CP0 (data) and CP1 (clock) and for USB 3.2 Gen 2, patterns CP9 (data) and CP10 (clock). Switching to the next CP pattern involves sending short LFPS sequences to the receiver in the USB device.

The R&S®RTP supports conformance testing for USB 3.2 Gen 1 (13 GHz model required) and for Gen 2 (16 GHz model) (Fig. 1). The SigTest analysis software is integrated into the R&S®RTP-K101 USB 3.2 conformance testing option, and the corresponding test sequence is automated. The option provides convenient graphical support to guide the user through the measurement. With the integrated two-channel 100 MHz generator option, switching between the

individual test patterns takes place automatically. Simultaneous testing of the short and long channels is another simplification. The trace from the short channel setup is processed using embedding filters generated on the basis of USB-IF S-parameter files to produce a long channel trace (Fig. 2). Complete test results are compiled in a detailed report.

USB 3.2 device error example

Fig. 3 shows an example of errors that occurred during the transmitted eye test for a USB 3.2 Gen 1 device. The random jitter (RJ) determined with the clock pattern (CP1) is especially noticeable. The corresponding eye diagram for the data pattern (CP0) also exhibits high jitter and noise. The analysis tools provided with the R&S®RTP make it possible to investigate the root causes of these problems.

Fast overview with the eye pattern

Eye pattern analysis is one of the best-known techniques for performing fast signal integrity tests. It

GENERAL PURPOSE

involves superimposing the individual data bits of a signal sequence (Fig. 4). Selection of the appropriate timebase for bit analysis is critical here. For all USB standard generations, 2nd order clock data recovery (CDR) is defined with different transfer functions.

The eye masks specified in the USB standard have a hexagonal shape (Fig. 5). The minimum height of the eye opening is specified with a value of 100 mV for Gen 1 and 70 mV for Gen 2. The minimum eye width is equal to the bit length (unit interval, UI) minus the maximum total jitter (TJ) that is defined for a bit error rate of 10^{-12} . For USB 3.2 Gen 1, this value is 68 ps and for Gen 2, it is 28.6 ps.

The R&S®RTP is equipped to generate eye diagrams with a configurable CDR that is implemented in the hardware and can be used as a trigger. A continuously running CDR enables a large observation interval for the signal stream that allows detection of sporadic errors. The mask can be configured in the eye center so that acquisition is stopped when a mask violation occurs.

Fig. 6 shows the eye test for the faulty USB 3.2 Gen 1 device that was mentioned above. As was already detected during the conformance test, the eye diagram exhibits a high jitter and noise component. The additional histogram on the right side of the eye clarifies the timing distribution of the bit edges and thus the jitter. The bimodal histogram format reveals some additional information: High deterministic jitter is also contained in the signal.

Resolving error sources due to jitter and noise components

A histogram in the eye diagram can provide initial insights into the jitter and noise contained in the test signal. However, in order to gain more detailed information about the interference sources, it is very helpful to

break down the total jitter and total noise into the individual components (Fig. 7).

For example, high random jitter (RJ) or high random noise (RN) can be a sign of problems in the semiconductor itself (thermal noise, shot noise) or an unstable clock oscillator. Deterministic periodic jitter (PJ) components can arise, for example,

due to an unstable PLL or interference from switching power supplies. Data dependent jitter (DDJ) components are divided into duty cycle distortion (DCD), e.g. due to asymmetrical signal edges and intersymbol interference (ISI). The latter can be caused, for example, by transmission losses due to low bandwidth of signal traces or by reflections on vias or connectors.

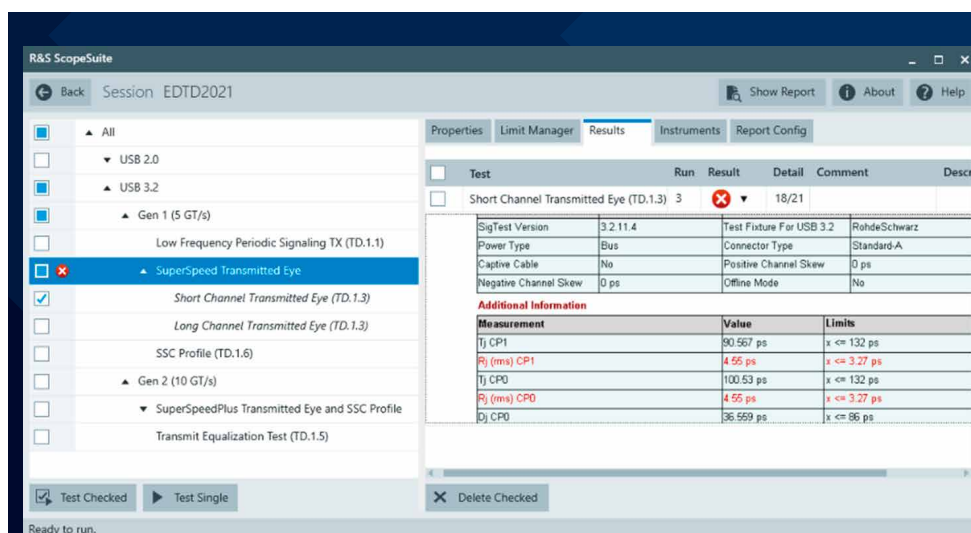

Fig. 3: The USB 3.2 Gen 1 conformance test report reveals abnormally high jitter in the results table (top) and in the eye diagram (right).

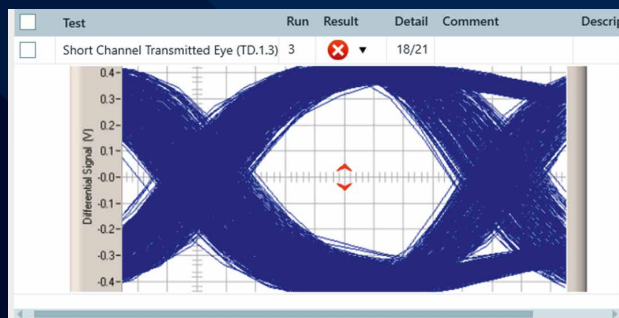
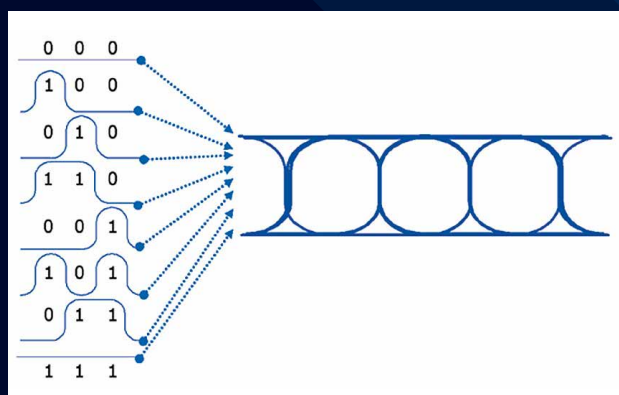

Fig. 4: The eye pattern is produced by superimposing bit sequences.



Once the jitter separation is completed, detailed results are available (Fig. 8). The results table (top right) shows that the periodic jitter (PJ) dominates the deterministic jitter. The random jitter (RJ + (O)BUJ) is also noticeably high. The PJ histogram has a distribution that suggests sinusoidal interference. The second table (bottom right) lists the estimated periodic jitter components. Here, high jitter

values are noticeable at 100 MHz. This is generally valuable information since the interference frequencies can be tracked back to the corresponding function blocks. Appropriate measures can then be taken to reduce the interference coupling. The power supply is a typical weak point. Interfering signals are easily injected via the supply lines and ground planes. In this example, the R&S®RTP

generator option was connected to the 5 V supply voltage of the USB device under test. The injected generator signal caused the periodic interference at 100 MHz, while the additional noise resulted in strong random jitter (Fig. 9). Comparison with the situation after switching off the interference source makes this clear (Fig. 10). Once the interfering signal is eliminated, the jitter measurement

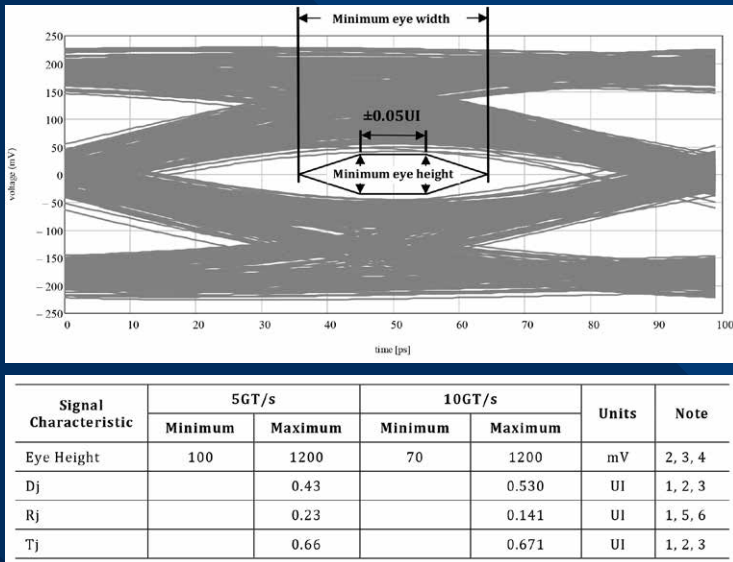

Fig. 5: Mask definition from the Universal Serial Bus 3.2 Specification, Revision 1.0.

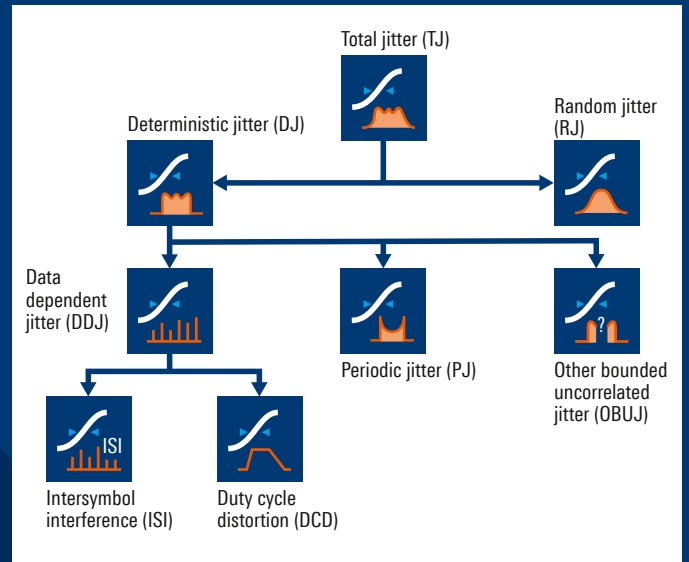

Fig. 7: The total jitter can be divided into random and deterministic components.

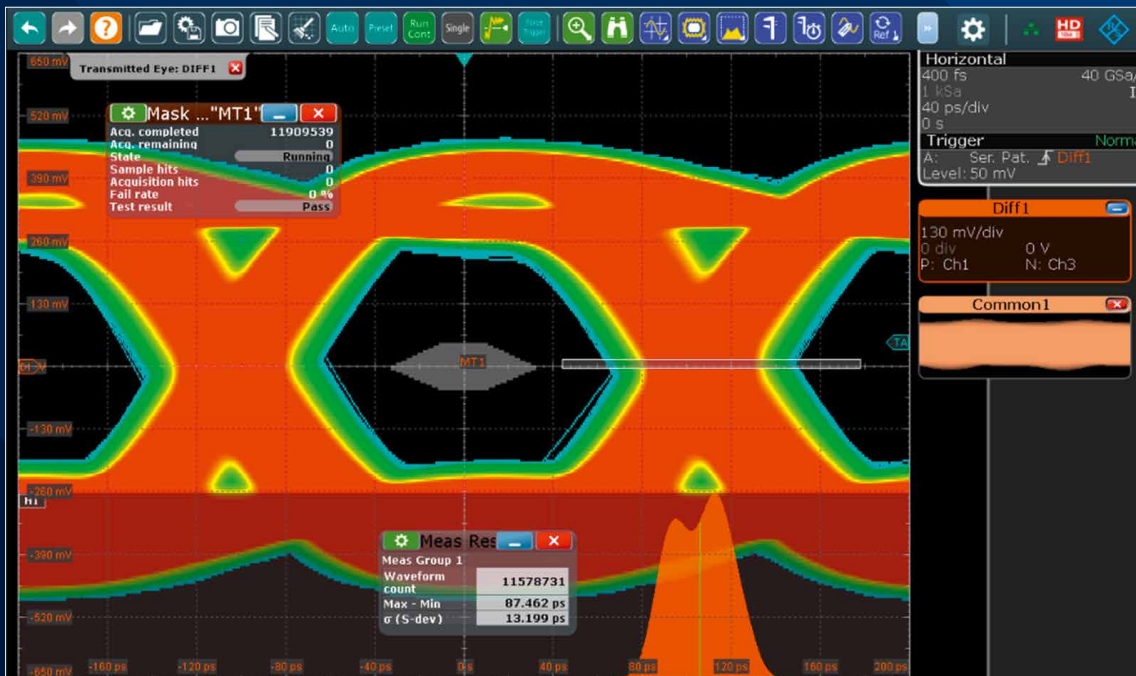

Fig. 6: Real-time eye pattern for the faulty USB device using hardware based CDR, mask testing and histogram with the R&S®RTP164 oscilloscope.

GENERAL PURPOSE

included in the conformance test passes with no problems.

Testing the signal path with TDR

In addition to analyzing the active signals, it is also important to check the signal paths in case of signal integrity problems. Here, the focus is on the transmission losses as well as the impedance response and stability along the signal path. Depending on the signal, the bandwidth of the signal paths on the printed board, the connectors, the cables, etc. requires appropriate design and selection. Impedance steps should also be avoided due to the reflections they can cause.

The relevant measurements are usually performed using network analyzers. The R&S®RTP with integrated time domain reflectometry (TDR) provides a useful alternative. The differential 16 GHz pulse source is used as a stimulus; its reference outputs allow measurement of the reflected signals with the oscilloscope channels.

The application software provides support during setup calibration as well as during the measurement. TDR can be used to measure the impedance and reflection coefficient along the signal path.

Fig. 11 shows measurement of a USB test fixture. The differential pulse source was connected to the SMA connectors. The USB type A connector was left open so the supplied signal pulse would be fully reflected. The impedance and the reflection coefficient can be displayed vs. time as well as vs. distance, allowing easy correlation to local sections of the device under test. We can clearly see the impedance step at the transition from the SMA connectors to the printed board, the constant impedance along the signal trace, and the reflection at the USB connector.

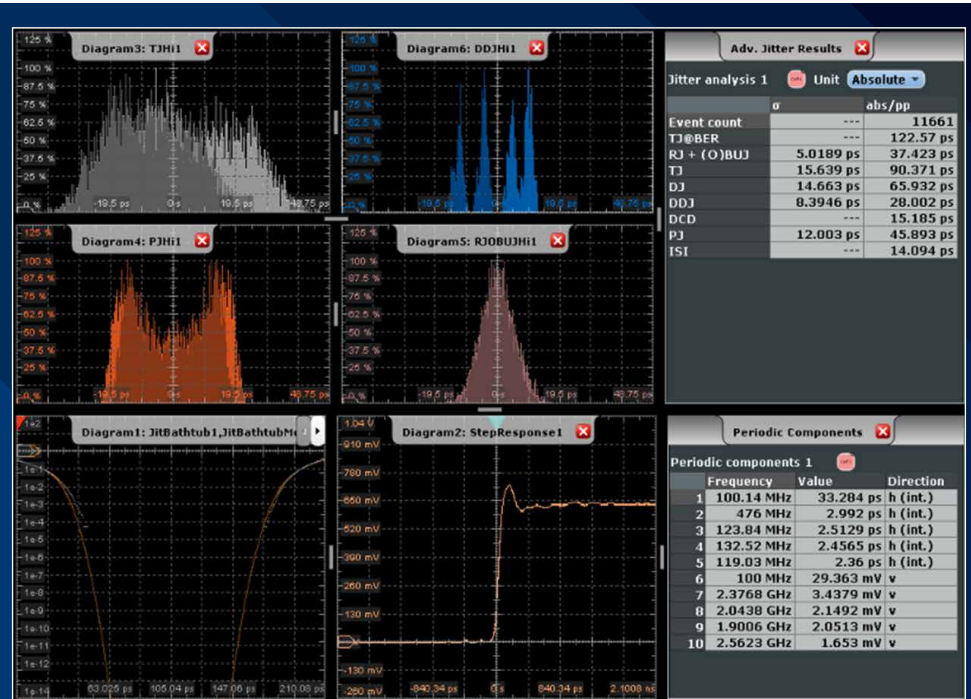

Fig. 8: Jitter separation results for the faulty USB 3.2 Gen 1 device.

Fig. 9: Periodic and random jitter are produced by injecting signals from the R&S®RTP generator into the 5 V supply voltage of the USB device.

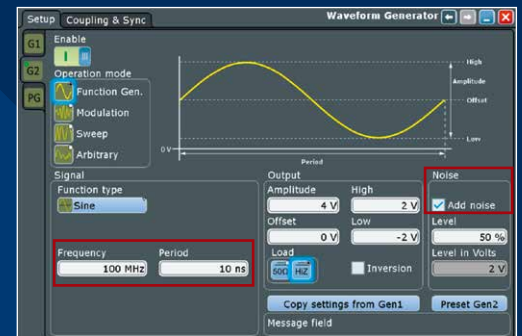
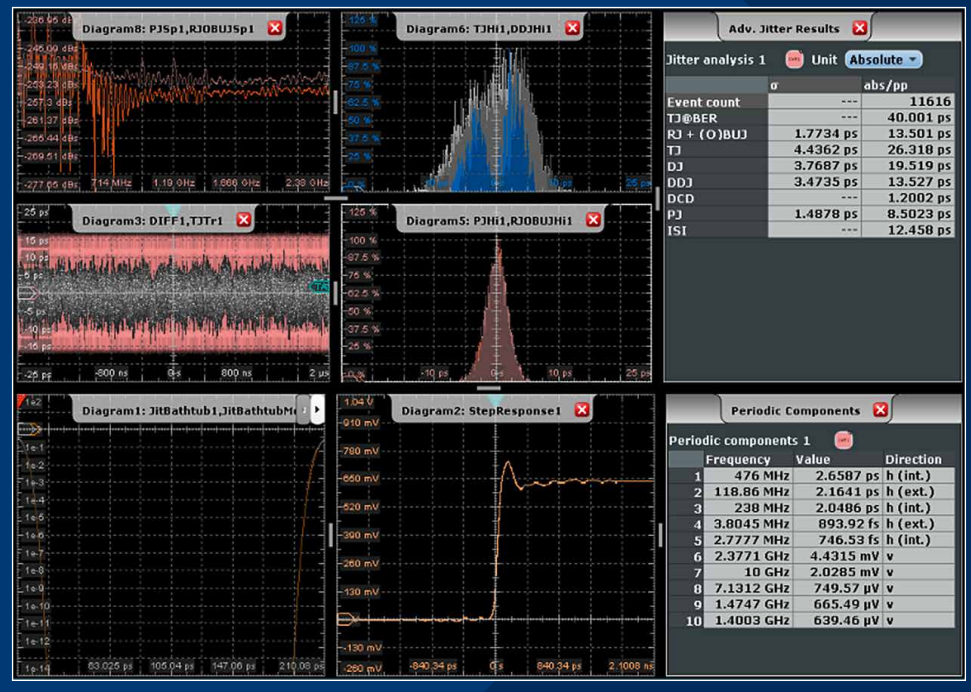

Fig. 10: Jitter results after switching off the interference source.



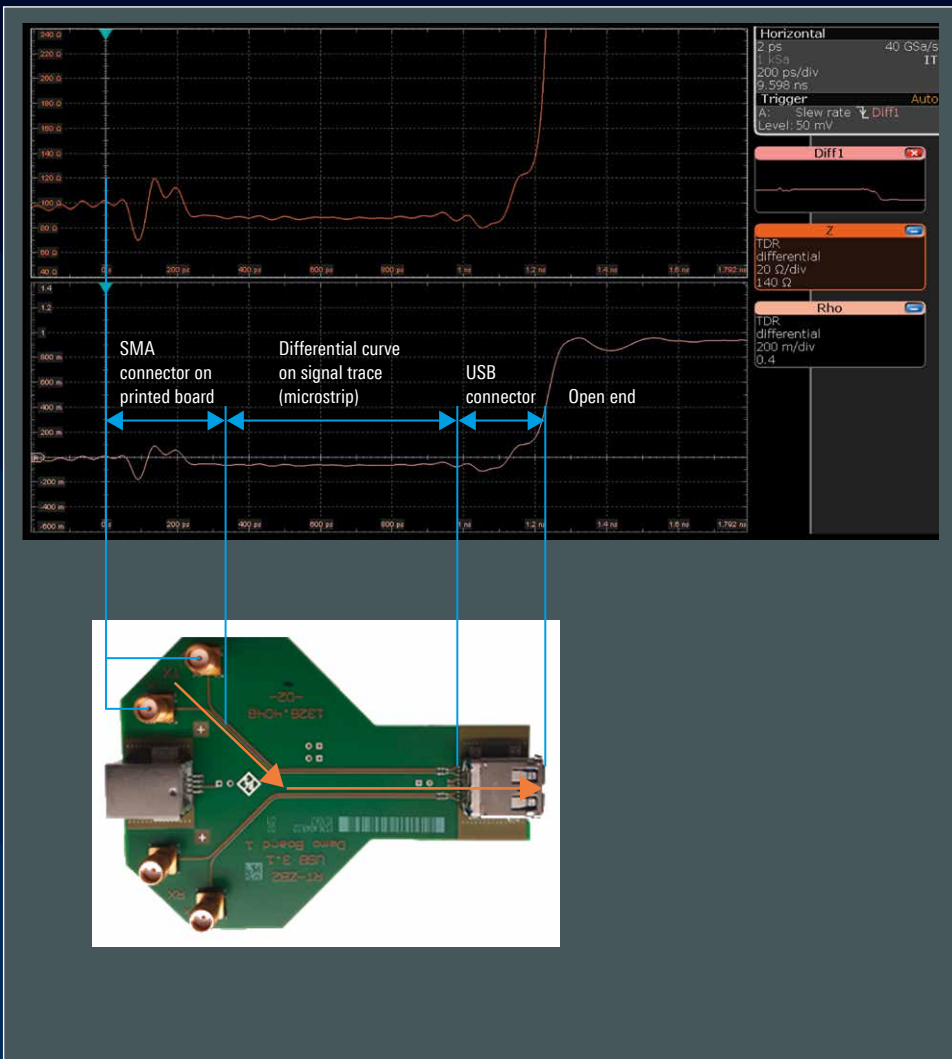
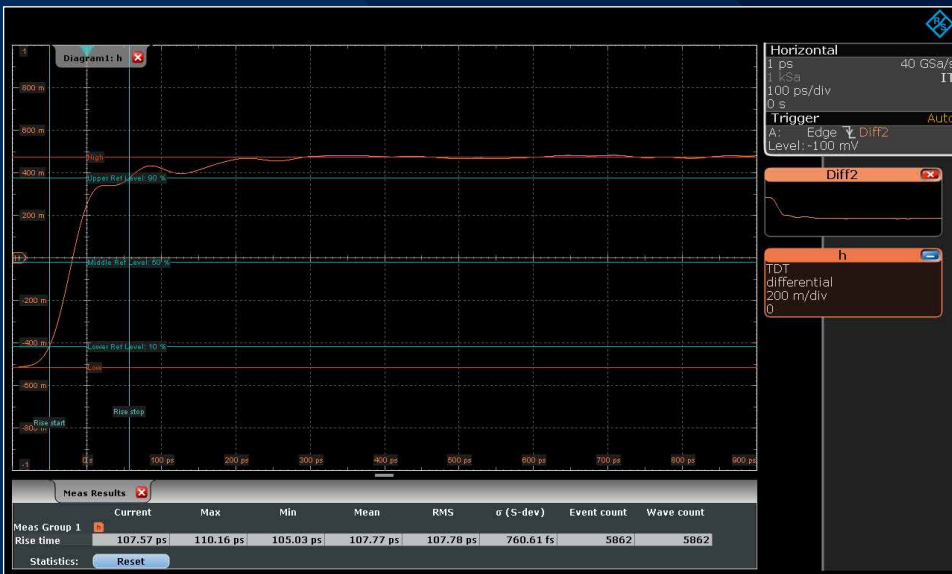

Fig. 11: TDR measurement on the USB test fixture: impedance (top), reflection coefficient (bottom).

Fig. 12: TDT measurement on the USB test fixture: The pulse rise time at the output is 108 ps.



Time domain transmissometry (TDT) is another useful measurement capability. Here, a fast pulse is also fed into the signal path. The output is connected to the oscilloscope channel to allow determination of the transmission losses. The TDT result shows the pulse shape that arises due to transmission losses. The rise time measured in the example in Fig. 12 suggests a bandwidth of about 3.2 GHz ($BW = 0.35/t_{rise}$).

Summary

Conformance tests on serial bus interfaces include important measurements when it comes to ensuring interoperability between electronic devices and their accessories. When errors are encountered, appropriate T&M equipment is the key to rapidly determining the root causes. Along with software options for performing automated conformance tests, the R&S®RTP oscilloscope provides a number of very useful tools for debugging signal integrity problems.

Guido Schulze

FOCUSING ON VERY LOW CURRENTS AND VOLTAGES

Battery-powered devices are getting smaller and smaller, and their current consumption is dropping to levels that are difficult to measure. But source measure units are up to the task. What's more: They can supply voltages and currents with high resolution.

Smart watches and other small devices operate on very small currents down to the nanoampere range. To enable technically sound development of devices with very low current consumption, power supplies that can both measure and reliably supply extremely small currents and voltages are needed – such as the new R&S®NGU series (Fig. 1). It enhances the range of Rohde&Schwarz general purpose lab DC power supplies with a class of precision source measure units (SMU).

Two different models are available, both of which can function as a source and a sink. The R&S®NGU201 operates in two-quadrant mode, while the R&S®NGU401 can also operate in four-quadrant mode, allowing it to supply and measure both positive and negative voltages, for example to test semiconductor devices.

Wide measurement ranges, rich features

Set or measured values can be viewed with up to 6 ½ digits on a large touch display, which also shows measured current and voltage waveforms and other graphics with high resolution. Both models can source and sink power up to 60 W, and currents up to 8 A. The units achieve

fast load recovery times of under 30 μ s in voltage priority mode and under 50 μ s in current priority mode.

The R&S®NGU user interface and features are based on the R&S®NGL/NGM series of special power supplies. For example, the interfaces (LAN, USB, GPIB) and current, voltage, power and temperature protection functions are the same.

The new top-end units provide even more sophisticated functions for shaping the output voltage or current. For example, the QuickArb function allows users to define up to 2048 current or voltage points per cycle, at intervals as short as 100 μ s. It is also possible to interpolate between these points to achieve an even finer resolution. For analysis, the FastLog function with acquisition rates of up to 500 ksample/s reveals extremely short-term current and voltage variations (Fig. 2).

Specifically designed for wireless communications applications, the R&S®NGU201 can optionally be turned into a battery simulator with a graphical display. It can accurately simulate user-configurable primary and secondary batteries, thanks to its integrated variable output impedance. The

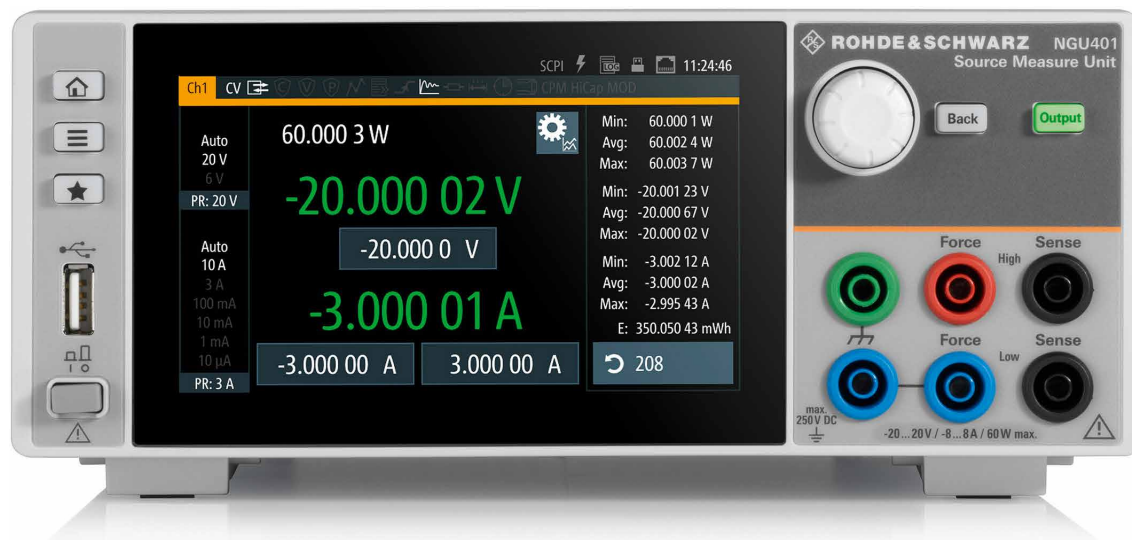

Fig. 1: With the two-quadrant R&S®NGU201 and its four-quadrant counterpart R&S®NGU401 (shown here), Rohde & Schwarz enters the market for precision power supplies (source measure units).

optional digital voltmeter that is galvanically isolated from the channel circuitry is another handy feature that in many cases eliminates the need for an additional instrument.

For users that require flexibility beyond modeling current and voltage characteristics with the QuickArb function, the four-quadrant R&S®NGU401 provides a modulation input for feeding arbitrary waveforms. This enables the unit to act as an AC current or voltage source and to simulate disturbances and unstable operating conditions.

Compared to conventional power supplies, the R&S®NGU source measure units offer two additional features that are important for practical measurements:

True current regulation

Standard lab power supplies only provide fast voltage regulation. While a current limit can be set and the device appears to provide current regulation in constant current mode, it is inherent in the design that this regulation is considerably slower than the voltage regulation. This results in large current overshoots under switch-on and load change conditions. Sensitive loads such as laser diodes frequently suffer damage from these overcurrents. To avoid this risk, the power supplies of the R&S®NGU series feature true current regulation, with a load recovery time (< 50 µs) nearly as short as that for voltage regulation, and reducing overshoots to a minimum (Fig. 3).

High-capacitance mode

The capacitor typically provided at the DUT input is a frequent source of error when measuring supply current and voltage. Together with the leads connecting the power supply to the DUT, it forms a lowpass filter that distorts measurement results. The R&S®NGU units feature a capacitance mode adjustable in steps, compensating the input capacitance, so that the current measured is the true current flowing into the DUT (Fig. 4).

Summary

Power supplies offering high measurement accuracy and the ability to handle currents and voltages in the nanoampere and microvolt ranges are needed to develop battery-powered mobile and IoT devices. The R&S®NGU series adds a class of precision source measure units to the Rohde&Schwarz portfolio of general purpose lab DC power supplies. The R&S®NGU201 two-quadrant model targets wireless applications, while the R&S®NGU401 four-quadrant model is the specialist for semiconductor tests. Along with a wealth of features that make testing simpler, the units have generously dimensioned heat sinks and barely

audible fans, making them extremely quiet – a feature that is often overlooked but very much appreciated by lab engineers. These units are indispensable for anyone who develops sensitive circuits or autonomous IoT devices.

Andreas Schütz

Fig. 2: Extremely short-term voltage variations, which might otherwise go unnoticed, can be captured with the FastLog function.

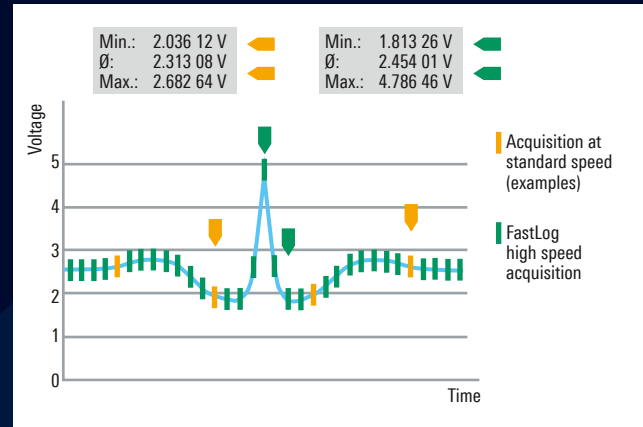

Fig. 3: Standard power supplies are optimized for fast voltage changes. This is at the expense of large current overshoots (left), which can damage sensitive DUTs such as LEDs. The current priority mode selectable on the R&S®NGU power supplies resolves this issue (right).

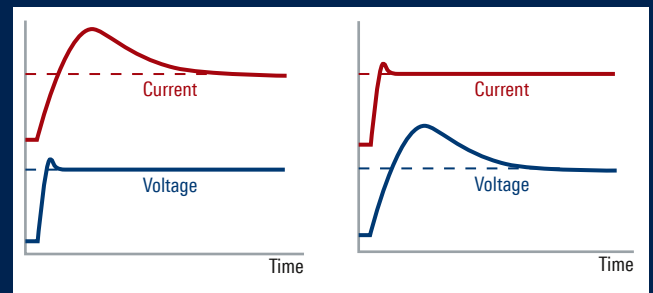
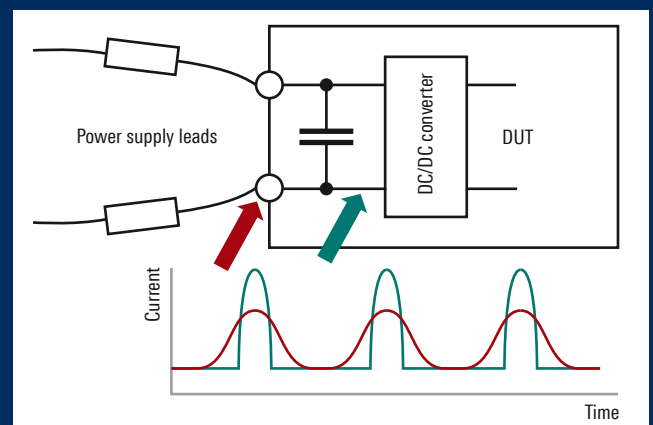

Fig. 4: The capacitance present at the inputs of many circuits distorts measurement results by filtering the supply current (red). The high-capacitance mode offered by the R&S®NGU ensures that the current measured is the true current flowing into the circuit (green).



REALISTIC SIMULATION OF RF SYSTEMS

Today, most RF developments start with a simulation of the planned system using an electronic design automation (EDA) tool. Realistic results, however, can only be expected if the simulator is fed with the same signals as will later be processed by the real system. This is now easily possible by combining high-performance signal generation and analysis software from Rohde & Schwarz with a widely used simulator.

Using the same signals for the simulation and the later hardware evaluation enables direct comparisons and simplifies a smooth transition from design to product. The Cadence® Visual System Simulator™ (VSS) is a widely used RF simulation tool. It supports the development of complex systems with all their function blocks and sub-modules, as well as system optimization for the required performance data, for example an RF frontend with filters, amplifiers and a phased array antenna system.

The latest signal formats at every point in the circuit in a fraction of a second

To supply the simulated system with authentic signals directly from the simulation environment, multifunctional R&S®WinIQSIM2 signal simulation software can now be plugged into the VSS as a source and R&S®VSE signal analysis software can be plugged in as a sink (Fig. 1). Both plug-ins and the necessary licenses are bundled in R&S®VSESIM-VSS software. Data transfer between the tools is file based in an assisted mode.

Both R&S®WinIQSIM2 and R&S®VSE support all important communications standards, including 5G and the latest Wi-Fi variants, and allow the handling of user-defined modulation schemes such as those used in satellite links. In addition, R&S®VSESIM-VSS contains the new R&S®VSE-K18 measurement option, which is especially useful in the development of RF frontends in general and power amplifiers in particular (Fig. 2). Along with standard measurements like frequency response and AM/AM or AM/PM distortion, it provides automatic EVM and ACLR measurements on all modulated signals without the need for specific analysis software configuration.

It is also possible to derive and apply different digital predistortion (DPD) methods based on nonlinearity measurements. Developers are faced with a multidimensional task in the optimization of an RF frontend and its amplifiers for the highest efficiency while complying with target specifications such as frequency range, gain and nonlinearity. Various options are possible in RF frontend design and in predistortion for linearization. Cadence® VSS with

Fig. 1: R&S®WinIQSIM2 signal simulation software and the R&S®VSE vector signal explorer can be plugged into the Cadence® Visual System Simulator™ RF simulation environment to enable generation and analysis of authentic signals from the simulator.

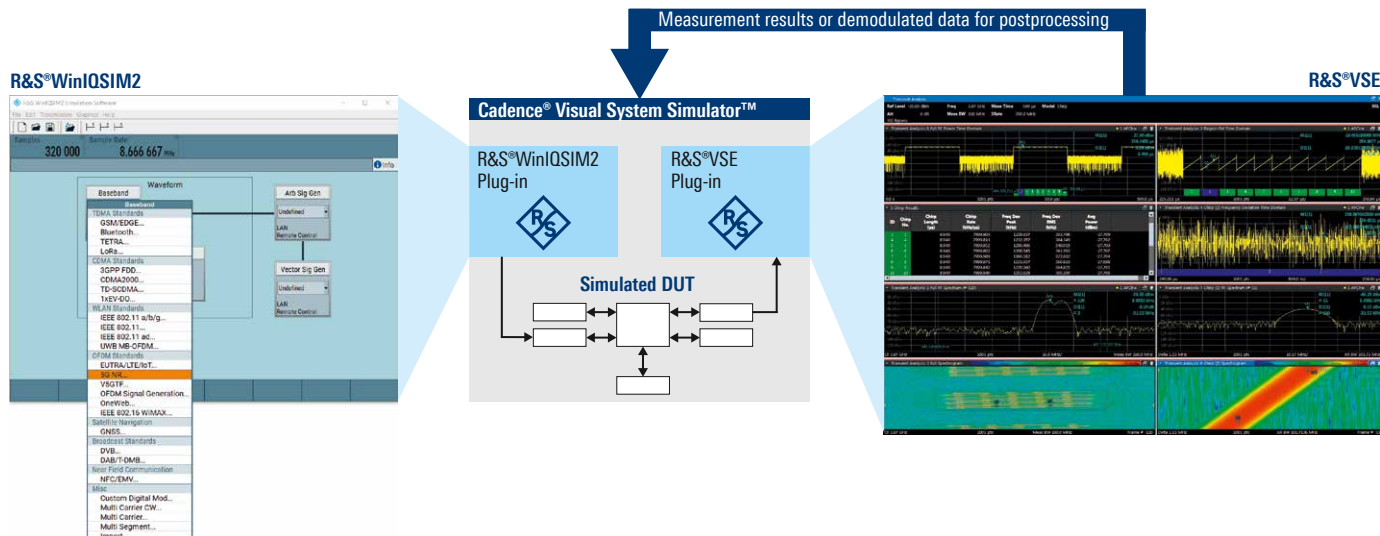

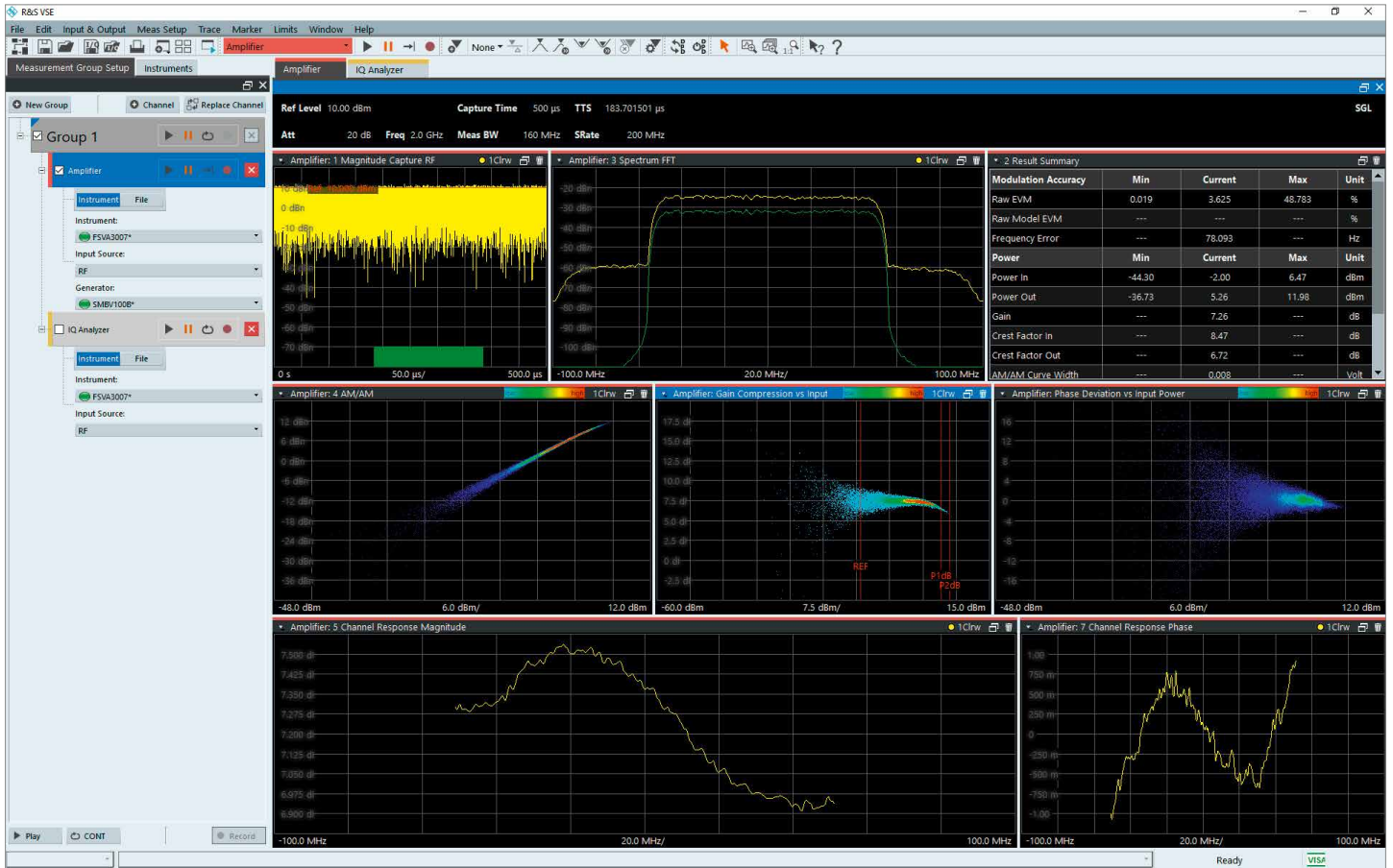

Fig. 2: Like many other signal generation and analysis options, the R&S®VSE-K18 amplifier measurement package is part of the R&S®VSESIM-VSS delivery scope.

integrated R&S®VSESIM-VSS provides all the required functions. Already during simulation, the system enables amplifier performance verification using direct DPD methods from Rohde&Schwarz. The new extension makes it possible to derive a memory polynomial model with user-definable complexity in terms of memory depth and polynomial order that can be used in subsequent real-time implementation. Using exactly the same DPD approach in the hardware later on ensures optimal correlation between simulation and hardware test after tape-out.

Since Cadence® VSS enables complete system designs, some components will be present in hardware earlier than others. In order to apply the same real RF signals to these components as those simulated in the virtual blueprint phase, the feed signal can be tapped at a suitable point in the simulator and fed to the R&S®VSE sink block. The sink block generates an I/Q file from this signal, which can be played back on a vector signal generator like the R&S®SMW200A.

Always up to date

The license concept for R&S®VSESIM-VSS follows the Cadence structure. Licensing is handled either by a file server or by a USB dongle, as known from R&S®VSE installations. The license has a lifetime of one year and needs to be renewed after this period. Thanks to this model, users automatically benefit from functional extensions through intermediate updates, for example when new modulation schemes are added with a new 5G release. Once embedded into Cadence® VSS, the test signals can also be used in other Cadence® products such as Microwave Office® circuit design software or the Virtuoso® IC layout suite.

Markus Lörner

COVERAGE IN EVERY NOOK AND CRANNY

The R&S®TLV9 low-power transmitter eliminates coverage gaps in DAB+ networks

DAB+ is now well-established in 35 countries and regions. In some places, it is used alongside classic FM service; in others, it is already the sole medium for terrestrial radio broadcasting. DAB+ has clear benefits. Besides ease of use, it provides high sound quality without interference, expanded programming and the ability to broadcast accompanying images and text. DAB+ receivers are also capable of receiving FM radio signals so that an either/or decision is not required. An EU directive has mandated support for DAB+ in all

radios that are installed in new cars. In some countries including Germany, this also applies to higher-end radios for use at home or on the go.



Of course, radio receivers are useless without broadcast programs to receive. Radio network operators in some countries are thus required to maintain DAB+ infrastructure alongside their FM networks. For operators, cost efficiency is key, that is why this requirement must typically be fulfilled without impacting the personnel and cost structure. In addition to



Fig. 1: Network operators can equip their complete DAB+ network with transmitters from Rohde & Schwarz and enjoy the benefits of one-stop shopping.

R&S®THV9evo

- ▶ Energy efficiency up to 50 %
- ▶ Up to 30 kW

R&S®TMV9evo

- ▶ Energy efficiency up to 50 %
- ▶ Up to 4.3 kW

R&S®TLV9

- ▶ Energy efficiency up to 30 %
- ▶ Up to 300 W



Fig. 2: Featuring output power from 50 W to 300 W, the air-cooled R&S®TLV9 low-power transmitter is an ideal gap filler for DAB+ networks.

regular operating costs, another relevant aspect is equipment robustness. When an FM transmitter fails, only a single radio program within the coverage area of the transmitter is affected. With DAB+, however, multiple programs are broadcast by the same transmitter using multiplexing. A failure can throw up to 15 stations off the air, both annoying the listeners and also leading to costly penalties for the network operator.

Rohde & Schwarz transmitters have long been renowned for their technical reliability along with many other qualities. Of course, the new R&S®TLV9 low-power transmitter shares the same qualities (Fig. 2). It rounds out the current platform of DAB+ transmitters, which already includes the R&S®THV9evo and R&S®TMV9evo product lines for high-power and medium-power scenarios (Fig. 1). With the low-power model typically used as a gap filler for existing coverage gaps, the power range now extends from 50 W to 30 kW. Broadcast networks are typically rolled out in multiple phases. The initial focus is on large-scale

coverage with high-power transmitters to provide most of the population with access to the new technology as quickly as possible. Expansion towards full coverage typically involves one or two additional phases. Given the current situation in many DAB+ countries, the R&S®TLV9 is arriving at just the right time.

The Rohde & Schwarz DAB+ transmitter platform has a range of features that make it extremely attractive for network operators:

All power classes from a single supplier

Thanks to the availability of low-power transmitters, the entire network can be deployed on the same technical basis. This is beneficial in areas including network monitoring and service.

Ensured service quality

The transmitters provide consistently high signal availability and quality over their entire operating time.

Maximum energy efficiency

Energy efficiency of up to 50 % helps to cut costs, especially in the

medium-power and high-power range. This efficiency is due to the sophisticated amplifier design, along with the R&S®Efficiency Optimization feature, ensuring optimum parameter configuration in every setup modification.

Long lifetime

Longevity is ensured by the tried and tested platform using high-quality RF components that the DAB+ transmitters share with the TV transmitters in combination with a clever thermal design.

Built-in performance analysis

The new self-monitoring function with intelligent performance analysis provides immediate feedback on the operating parameters along with clear diagnostic information.

Ever since launching the first DAB transmitter back in 1995, Rohde & Schwarz has played a significant role in the development of the DAB+ standard. The new platform reflects the company's expertise that was built up over decades.

Silke Kürmayer

SECURELY WORKING FROM HOME

Thanks to highly secure software tools, even government agencies and companies with high security requirements can now allow their employees to work from home.

During the coronavirus-driven rush to relocate office workers into home offices, data security was not always the top priority. As it has become clear that the work of the future will be organized on a more decentralized basis compared to the pre-coronavirus era, however, potential vulnerabilities must be systematically eliminated. Products from Rohde&Schwarz Cybersecurity can be used to reliably safeguard work within distributed organizations. Even

simple handling of classified material is supported with no problem.

Communications security solutions approved by the Federal Office for Information Security (BSI) from home and on the go

In response to the COVID-19 pandemic, many companies were able to rapidly shift a large share of their employees to home offices. In

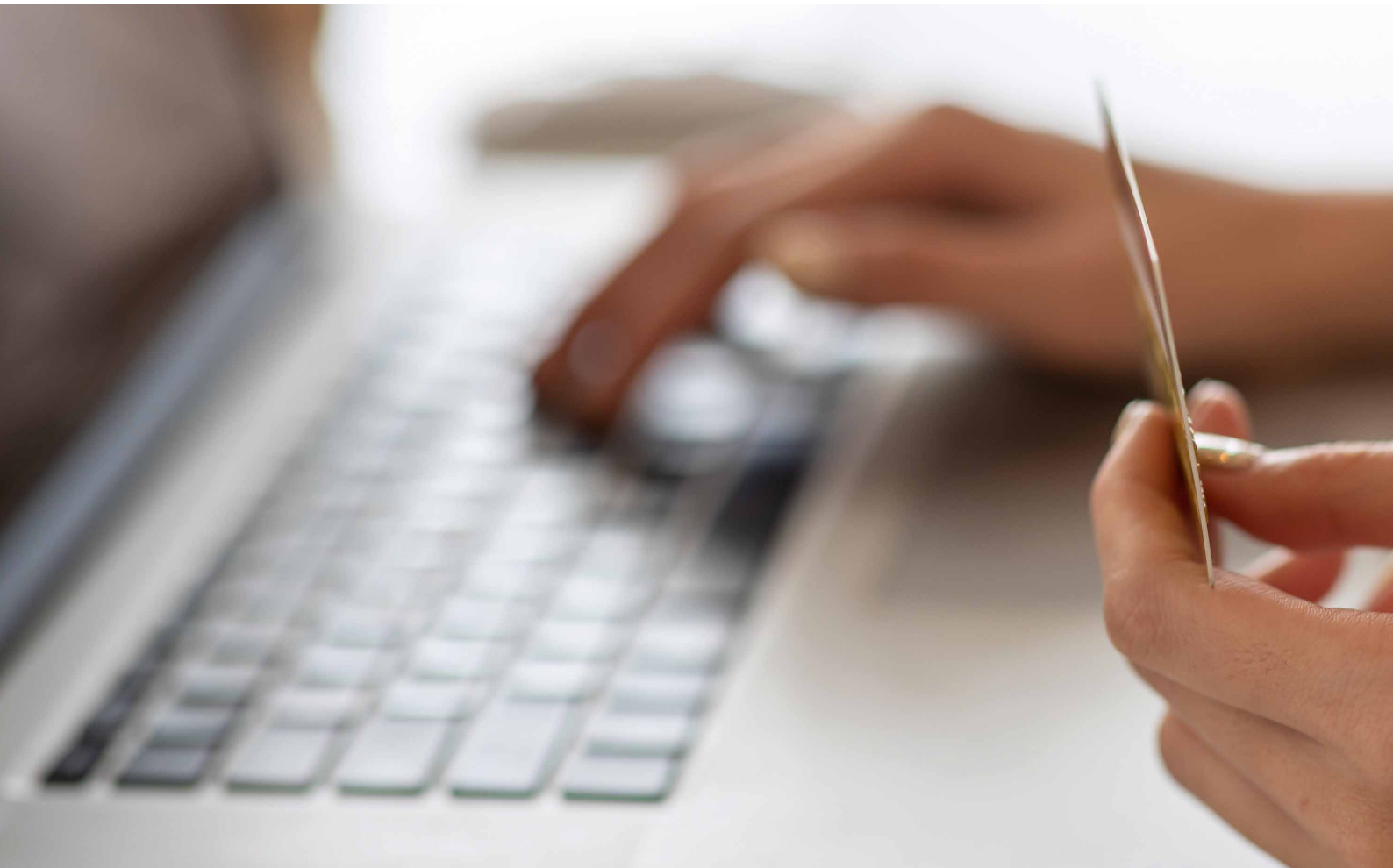

order to protect corporate data, however, encrypted communications are a must. Remote employees are connected to the corporate network via a virtual private network (VPN) tunnel. Available software VPNs offer good basic protection, but they are not impenetrable. A VPN client runs on the operating system, which makes it vulnerable. If Windows is infected with malware, the VPN client is also impacted and an attacker could potentially disable the secure connection. Unencrypted data could then be intercepted by the attacker – unnoticed by the user. Germany’s Federal Office for Information Security (BSI) recommends that VPN solutions used for classified and especially sensitive information are independent of the operating system. Until now, this was only possible using additional hardware VPN boxes. Government agencies that work with data generally classified as RESTRICTED were unable to relocate their employees to home offices from one day to the next on the same scale as in private industry. It would have

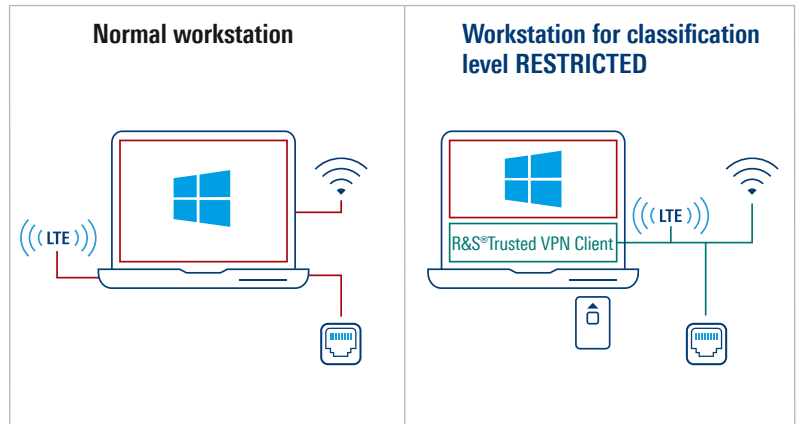

Fig. 1: The operating system (red) normally controls the data interfaces, e.g. Wi-Fi, cellular network, Ethernet. R&S Trusted VPN Client (green) takes control away from the operating system to ensure a secure environment. The user is identified via a smart card.

been necessary to purchase an overly large number of VPN boxes on short notice.

In the future, however, highly secure communications can be easily implemented for use in the home office and on the go. R&S Trusted VPN Client is the first pure software solution to receive BSI approval for the RESTRICTED, NATO RESTRICTED and RESTREINT UE/EU RESTRICTED classification levels. For user authentication, all that is needed is a smart card that is inserted into the laptop.

R&S Trusted VPN Client is a zero trust solution that does not rely on potentially unsecure components such as an operating system. The underlying principle involves strict interface control. The operating system is denied access to all network interfaces within the computer hardware. The concept is implemented using a virtual machine. The software also known as a hypervisor is implemented between the computer hardware and the operating system to control the data flow between them. R&S Trusted VPN Client ensures that Windows recognizes the VPN client as the sole network interface (Fig. 1). This channel, which is cryptographically hardened in line with BSI requirements, is the only path via which data can leave the operating system. Physical access is possible via LAN, Wi-Fi and mobile networks. Connections through captive portals, e.g. in hotels or high speed trains, are also supported. If the VPN client detects a secure network such as the office network, it deactivates itself automatically. Secure communications are ensured under all conditions. There are hardly any



© David / adobe.stock.com

limitations in functionality. Everything required of a home office workstation is supported, especially including VoIP phone calls and video-conferences. A virtualized browser such as R&S®Browser in the Box is recommended to protect scenarios with external participants connected via a potentially insecure link (see below).

Closing off the biggest gateway for malware

The restricted internal area of an organization can be configured for high security using VPNs like R&S®Trusted VPN Client. A critical situation arises whenever communications must leave this restricted area and access external servers. The browser is by far the most common entry point for cyberattacks. Use of applications, collaboration tools, email and downloads via the browser can lead to injection of malicious programs that can potentially damage not only the user’s own computer but also quickly allow an entire network to be attacked. Developed in cooperation with the BSI, R&S®Browser in the Box ensures that malware of this kind does not have a chance. This is achieved by fully separating the browser from the operating system. The Chrome or Firefox browser runs in a virtual environment built on a hardened Linux operating system. Since the browser cannot directly access the file system and interfaces, malware is unable to spread through the computer hardware and network. Files that are downloaded land initially in a secure, isolated environment (docs in the box). They can then be safely

opened using the supplied Office and PDF document viewers.

In this age of work from home, web conferencing with a browser is a must. Microphones and cameras are important security issues. If an attacker manages to hijack these resources without being detected and still controls them after the end of a conference, significant damage may occur. However, this risk can be eliminated by incorporating audiovisual interfaces into the virtual environment provided by R&S®Browser in the Box. Starting with version 6.0, the user has total control over the camera and microphone if the administrator grants these permissions. Both are ensured to be offline after they are deactivated via the user interface or by closing the browser. This feature is compatible with videoconferencing tools like Microsoft Teams, Zoom, GoToMeeting, Jitsi and Circuit.

Working with R&S®Browser in the Box is just as easy as ever. The PC performance is also not diminished. Companies, academic institutions and government agencies can take advantage of the internet while still maintaining high security.

Secure data exchange via collaboration tools

R&S®Browser in the Box eliminates the risk of malware during browsing and videoconferencing sessions. However, it does not necessarily prevent the undesired outflow of exchanged files or chat messages. Although the security of

Fig. 2: When R&S®Trusted Gate is tasked with data management for cloud applications, only empty file shells with harmless metadata are uploaded to public clouds like Microsoft® 365. The actual data is stored in a fragmented state with strong encryption on user-definable servers. The files are reconstructed when they are opened and made available via a secure channel.

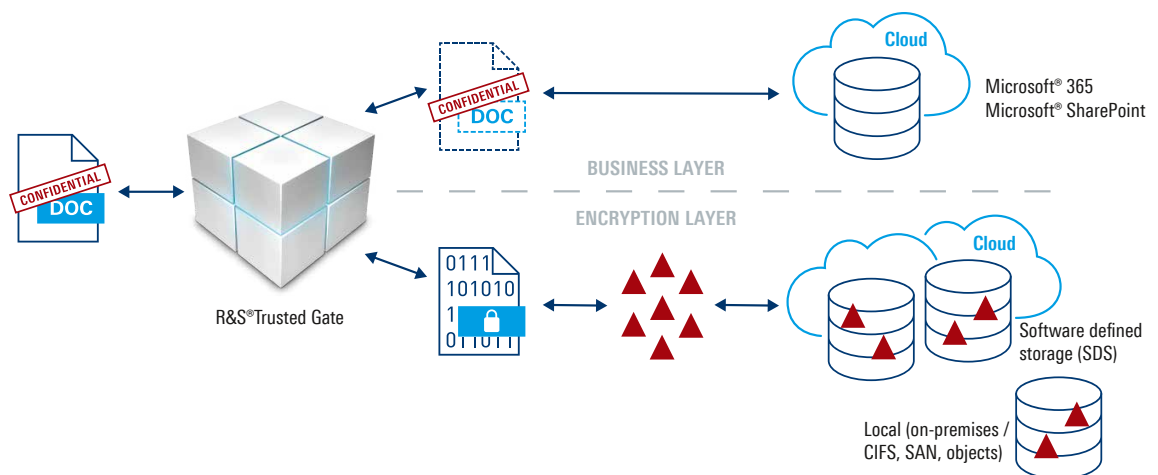

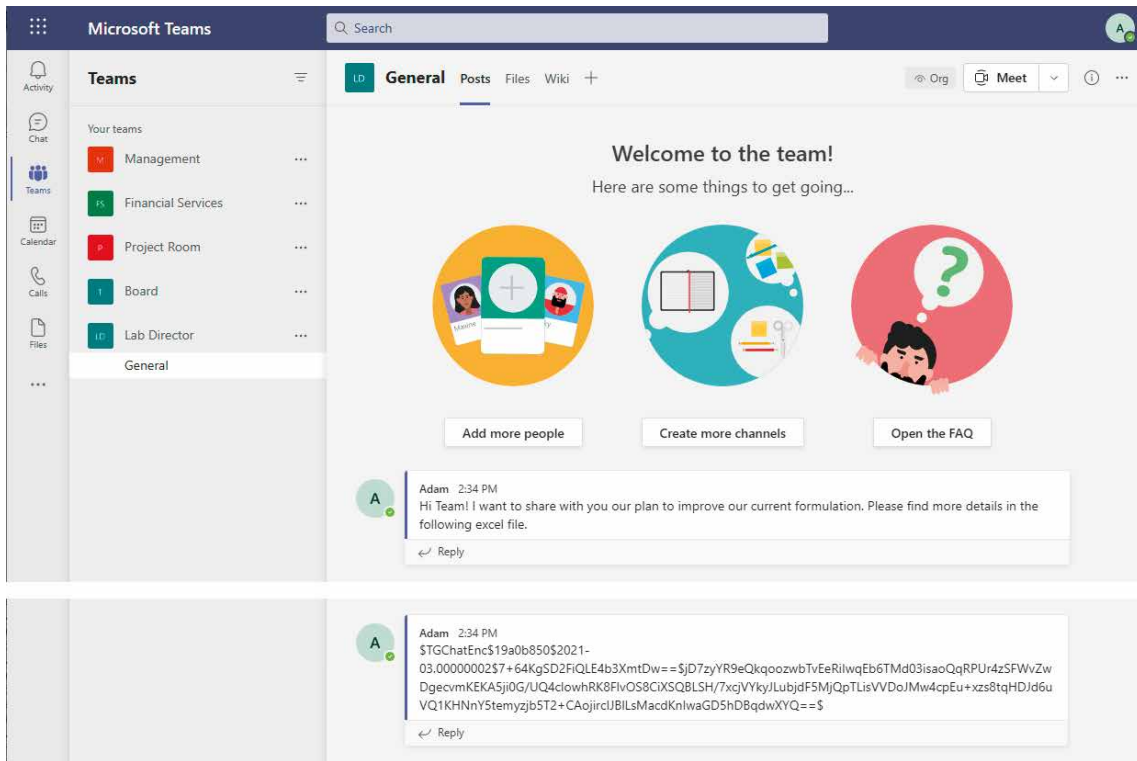

Fig. 3: When Microsoft® Teams is used together with R&S®Trusted Gate, unwelcome onlookers only see scrambled data in the chat conversation (see screenshot below). Unauthorized access to uploaded files is also prevented.

popular tools like Microsoft Teams is constantly improving due to measures implemented by the providers, organizations with high security requirements should only rely on security solutions that are under their full control – especially when it comes to encryption and data storage. R&S®Trusted Gate is the ideal solution for this.

R&S®Trusted Gate is a cloud security solution that is based on a consistent data-centric approach. Access to data is not managed primarily on the basis of user rights. Instead, it is defined by the protection category that was assigned to the data, e.g. company confidential or classified. Only persons who have been granted rights for the applicable category can view, read or edit the data. The data is encrypted and broken into small chunks that can be stored on user-definable local or cloud storage in a GDPR compliant manner (Fig. 2).

The software integrates with collaboration tools like Microsoft 365, Teams, OneDrive and SharePoint – seamlessly and invisible to the user. The cloud provider never has any access to the original data. Even though the Court of Justice of the European Union (CJEU) has declared the EU-US

privacy shield to be invalid, R&S®Trusted Gate still allows lawful usage of these cloud services by implementing pseudonymized access to the services. Personal data is never transferred to non-European clouds.

R&S®Trusted Gate features are expanded step by step. For example, the current version of the software also supports encrypted file and chat exchanges using Microsoft Teams. Data sent via this service remains absolutely confidential (Fig. 3).

Summary

Secure handling of sensitive data is now supported with no problem even when working from home. No special hardware is required. Rohde & Schwarz Cybersecurity provides government agencies, companies with facility security clearance, operators of critical infrastructure and organizations with high security requirements with state-of-the-art, BSI-tested software solutions that satisfy all legal requirements and are just as easy to use as conventional tools with lower security.

(Ed.)

ICARUS FLIES



Since September 2020, ICARUS has been used, for example, to track the intercontinental migrations of blackbirds and thrushes.

© Marcel Schauer – stock.adobe.com

The ISS based project for researching the migration behavior of a variety of animal species has commenced operations. Radio technology from Rohde & Schwarz is used for data transfer.

The project participants had to overcome many hardships before they could celebrate the start of regular ICARUS operations. As Director at the Max Planck Institute of Animal Behavior in Radolfzell, Germany, Professor Martin Wikelski is the initiator and mastermind behind this project. The idea of observing animals from space came to him some 20 years ago. He has worked diligently since that time to bring the concept to fruition. Frequent setbacks tested his tolerance for frustration. Even the project name is testimony to Wikelski's grim humor: The uninterested NASA predicted the project would never fly – just as the mythological Icarus was doomed by his highflying ambitions. The European ESA also declined to support the project. However, thanks to the Russian space agency Roskosmos (one of the main ISS operators) and the German Aerospace Center (DLR), this modern ICARUS was finally able to take to the skies. The name was transformed into an acronym that fits this serious project: International Cooperation for Animal Research Using Space.

From utopia to reality

Of course, the original idea was both daring and – from our current perspective – unfeasible using technology from the early 2000s. It was something to make a science fiction author proud: The notion that thousands of tiny solar-powered computers, loaded with sensors and radio modules, could autonomously communicate with a satellite in space from everywhere on earth and form an “internet of animals”.

However, rapid advances in the miniaturization of electronics and sensors as well as in batteries and solar cells were enough to turn this utopia into reality in recent years. INRADIOS, a small startup specializing in satellite communications that had just been founded by post-doctoral researchers in Dresden was given the challenging task of designing the radios for the project. They were supported by experts in the field of space technology from the company SpaceTech and the DLR. Now a member of the Rohde & Schwarz group, INRADIOS is working

Fig. 1: The ICARUS tag is hardly bigger than a euro cent coin. A special handheld radio is needed to fully read out the data memory. This radio can be used to command tags within a radius of a few kilometers to transmit their data. The radio forwards the data via WLAN to a smartphone or tablet which is used for actual operation.



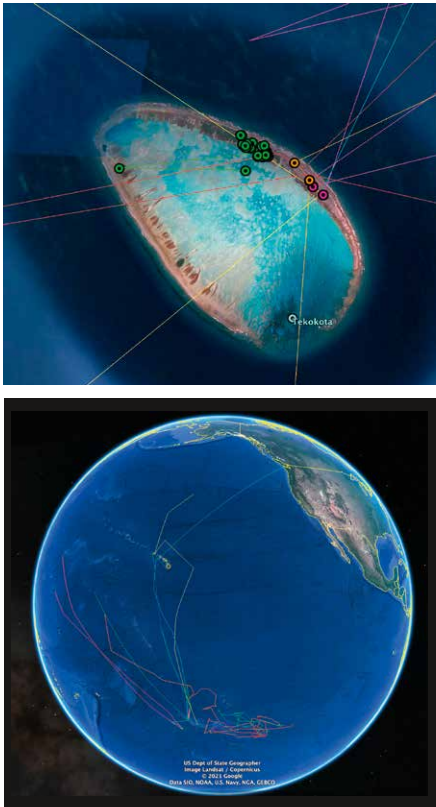

Fig. 2: Small scale or large scale: Animal migrations can be tracked over any route – as seen in this example from Polynesia.

to further develop the ICARUS technology in close cooperation with the Max Planck Institute (MPIAB). Rohde&Schwarz is responsible for manufacturing the radios (Fig. 1).

Keeping a close eye on the animals

The most important condition for a viable animal transmitter (tag) is that the species under study must tolerate wearing the tag.

As recommended by ethics committees, the tag should not exceed 3 % of the animal's body weight in order to avoid influencing the animal's behavior or even endangering it. Since it was also planned to equip small animals with the tags, the upper limits for the size and weight were very difficult to meet. The trackers based on mobile or analog radio that were conventional at that time were ruled out for animals under 1 kg, meaning that 75 % of all bird and mammal species could not be studied. The blackbird was chosen by the MPIAB as a reference animal due to the long-term focus on this songbird within the observation program. Prototypes of the ICARUS tag were tested preferably on these seemingly familiar birds – but whose



Fig. 3: There are only about 50 000 specimens of the Hudsonian godwit left worldwide. This bird flies nonstop from Chile to North America over a period of one week before traveling onwards to Canada. ICARUS is providing detailed data about its migration routes and resting areas. The project is supported by Chilean biologists.

migration behavior still brings up questions that could only be answered by means of continuous monitoring. Weighing in at 4.5 g, the lightest version of the tag is just light enough for the blackbird, assuming its use is limited to adult male specimens. For all other species to be fitted with a transmitter according to current ICARUS planning, the recommendation is easily fulfilled.

Along with the radio and location technology, the tags contain multiple sensors as well as enough memory to store the movement and environmental data for a single animal during its entire life (see box on next page). Up to 20 sets of position data are transmitted to ISS during each overhead pass, which generally occurs daily but can take place every three days at higher latitudes. The limited amount of data is due to the brief contact window of only 15 seconds (of which 3 seconds are used for transmission)* and the low bandwidth of the radio link. The fact that a miniature radio with only six milliwatts of transmit power can communicate with a satellite is extraordinary in itself. This is made possible by the large, high-performance

* Due to its high orbital velocity of 28 000 km/h and low orbital altitude of about 400 km, ISS has such a high angular velocity over the ground that it is only briefly in range of ground transmitters.

ISS antennas as well as sophisticated radio technology.

The tags use the regularly transmitted ISS ephemeris data along with their own position to calculate the next time of contact. They prepare to receive and transmit during the calculated time window, but mostly remain in standby mode to save power. Based on the regularly transmitted tracking data that is compiled in the database at movebank.org, researchers have already gained valuable insights (Figs. 2 and 3). However, another component is needed to access the entire data trove accumulated by the tags, including the environmental data. Migratory birds do not move constantly. Instead, they remain for longer periods of time in their winter and summer habitats. For most other species, the radius of movement is clear. This allows biologists to visit them in their habitats and make contact using an ICARUS handheld radio (Fig. 1). A stable and much faster radio link can be set up on the ground that covers a distance of up to a few kilometers, allowing convenient readout of the tag memory without time pressure.

By combining various types of sensor data with precise position information, researchers are gaining entirely new insights into the living conditions and behavior of animals – especially if

external weather and environmental data can be included. Once a few thousand “ICARUS birds” are flying, they could be used as meteorological drones to feed data to a global weather monitoring system. However, this would require an update to the transmission technology along with additional satellites in orbit. Nevertheless, this is the vision that Wikelski is targeting. Operation of ISS is only ensured until 2025. If the countries responsible for its operation cannot agree on its continuation, it might be possible for autonomous ICARUS satellites to take the place of ISS. Although the financing is obviously a challenge, MPIAB is refusing to be discouraged – especially in view of the other hurdles this project has already overcome.

Balancing the different interests

The tags are designed for a long life since they are expected to function during the animal’s entire lifespan and even allow reuse. In principle, this is a desirable feature. However, it can become a problem if the tag remains in the wilderness after the animal dies. Electronic components do not decay. Mechanisms were thus implemented to make it easier to find and collect the used tags. Once a tag is no longer moving, its GPS position becomes stable. The handheld radio can be used to switch the tag to ping mode so that it functions as a beacon transmitter. Then, the tag can be roughly localized with the radio. In addition, the tag calls attention to itself with a flashing LED. In case a third party finds the tag first, a contact address is provided on the rear of the tag. It is hoped that on the basis of these measures, the vast majority of the used tags will find their way back to MPIAB. The institute is paying close attention to this issue.

After all, the biologists feel committed to the protection of ecosystems by virtue of their profession and not least out of conviction.

If the ICARUS project grows by another order of magnitude, it will be essential to reevaluate the project in light of sustainability issues. Organic electronic components are still far from commercial maturity. However, the developers might come up with some other ideas. Now that ICARUS has taken to the skies, it is a matter of ramping up the system and using it to full advantage for the intended purpose.

(Ed.)

Global

songbird migration

Billions of songbirds migrate between continents twice a year. Songbirds are valuable to the ecosystem, but their numbers have declined by 30 % over the past 20 years. It is unclear how they can be protected – which is why there is interest in learning more about their living conditions.

Animals protecting animals

Rangers are important for protecting wild animals since they can keep poachers at bay. Although they cannot be everywhere simultaneously, the animals can. Based on their collective behavior, it is possible to draw conclusions about the presence of predators or poachers, allowing rangers to be deployed as needed.

Pandemic prediction

As the habitat for many animals is increasingly encroached upon, both the frequency and intensity of contacts between people and wildlife are increasing. Pathogens can cross species as a result. COVID-19 is suspected to have entered the human population in this manner. In the animal kingdom, the usual suspects include bats. However, they are only an intermediary. ICARUS should help to identify the original sources of diseases.

Animal transmitter (tag)

- ▶ Weight: < 5 g, depending on battery size
- ▶ Antenna length: 20 cm (radio) and 7.5 cm (GNSS)
- ▶ Sensors: magnetic field, acceleration, temperature, humidity, pressure
- ▶ Data memory: 512 Mbyte
- ▶ Battery capacity: 70 / 60 / 45 mAh
- ▶ GaAs solar cell (top-performing technology at this time)
- ▶ Transmit power: approx. 6 mW
- ▶ Transmit frequency: 402.25 MHz, 1.1 MHz bandwidth
- ▶ Receive frequency: 468.1 MHz
- ▶ Transmitted data set: 223 bytes/ISS contact

SOME ONGOING AND PLANNED ICARUS PROJECTS



All photos: ©MPIAB



Understanding the "lost years"

The most difficult time for most animals comes when leaving their place of birth. For many species, the young animals disappear off the radar screens of biologists for years. ICARUS should help to close this knowledge gap. The focus is on mammals as well as turtles and seabirds.



Movement of human/animal communities

Since early history, humans have traveled with certain livestock animals. These joint migrations can still be observed in some remote locations. Exactly who is leading and who is learning from whom? Researchers are preparing to study these questions in Bhutan (Himalayas), the southern Sahel region, Bolivia and the High Arctic.



Movement of shorebirds and seabirds

Many shorebirds serve as a link between the earth's hemispheres. During their long journeys, they rely on coastal regions to nourish themselves. However, suitable regions are becoming increasingly rare due to the omnipresence of humans. Where should protected areas be established? Seabirds are among the most puzzling species. Which maritime regions do they prefer? How do they navigate? How do they sleep? Seabirds are also good for monitoring climatic phenomena like El Niño. They can continuously measure winds, salinity and ocean currents and provide information about where the next typhoon or hurricane is forming.

SMART UPLINK AMPLIFIERS

With their built-in monitoring and control functions, the R&S®PKU100 series of satellite uplink amplifiers have always been the smartest of their kind. Now they additionally provide an integrated system control for redundant configurations.

The R&S®PKU100 amplifier series from Rohde&Schwarz targets satellite uplink stations, also known as telecommunications ports (teleports). These teleports transmit satellite TV signals to geostationary satellites, which in turn provide coverage to households in their target regions. For many years, however, the evolution of communications satellites has been driven by data services such as internet via satellite.

In the next two years alone, geostationary internet satellites with a net transmission capacity of more than 4000 Gbit/s will be launched into orbit, doubling existing capacity.

Teleports provide the link to terrestrial data backbones. To handle the enormous data throughput per teleport, the allocated spectrum must be fully exploited using advanced modulation methods such as 64APSK. This distinctly increases the demands on signal quality. Teleports are also subject to strict availability requirements. Both factors have consequences for the deployed uplink amplifiers. Although the market is still dominated by tube amplifiers, with the R&S®PKU100 series (Figs. 1 and 2), Rohde&Schwarz has opted for solid-state

technology, which offers advantages in terms of signal quality, operating costs, lifetime and reliability.

Zero outage

Zero outage is ensured by a variety of measures. For example, protective mechanisms prevent damage from overtemperature or excessive reflections at the RF output. Fans and power supplies can be configured redundantly to enable hot swapping, so that failure of these components has no effect on operation. Even if a transistor fails, more than 75 % of the nominal output power is still available, unlike the failure of a traveling wave tube, which requires immediate replacement of the amplifier.

Nevertheless, for liability reasons teleport operators play it safe and choose complete redundancy, enabling them to deal with all eventualities. With tube amplifiers, a second amplifier must constantly be running in hot standby (active mode), so that it can take over immediately if necessary, but a solid-state amplifier can remain in cold standby (passive mode), thereby saving energy. But the redundant R&S®PKU100 is put to good use in another way: It also acts as a system controller that keeps an eye on all operating conditions and displays them on the web GUI (Fig. 4). It independently issues alarms in case of deviations from nominal conditions

Fig. 1: The R&S®PKU100-0750 outdoor model with 750 W output power.



Fig. 2: The 400 W R&S®PKU100-1400 indoor model.

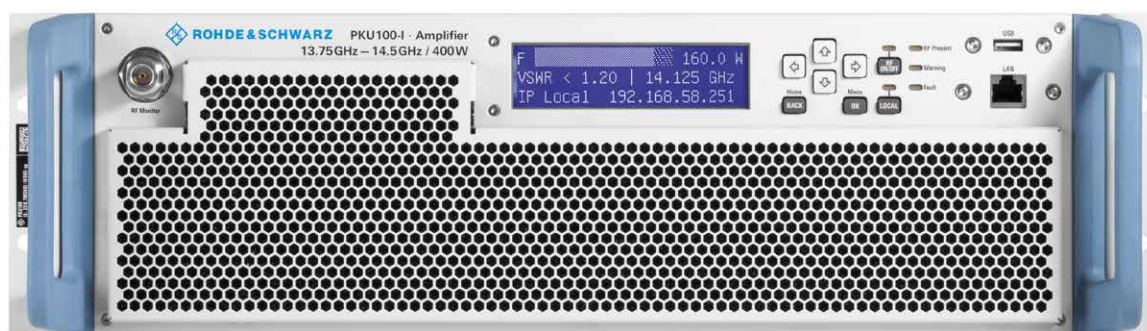

and, in particular, can immediately switch from cold standby to the active state if any of the active amplifiers has a problem.

Depending on whether a single horizontally or vertically polarized satellite transponder is to be served or two different polarizations at the same time, one or two amplifiers are connected to an antenna designed for both polarization directions. In both cases, the amplifier system is configured as n+1 redundancy (Fig. 3). In a 1+1 system, two R&S®PKU100 operate in a fully symmetrical configuration. The two units monitor each other. This means there is no single point of failure any more – unprecedented in the field of uplink amplifiers. The backup amplifier is the controller “in charge” and handles communications with the operator. If there is a malfunction in the active amplifier, the backup amplifier seamlessly takes over RF amplification and turns its RF switch to the antenna. Similarly, in a 2+1 system, no additional control unit is required. This makes installation and operation of these slim systems very easy.

The sum of their characteristics makes R&S®PKU100 systems a safe investment for operators in every regard.

Maurice Uhlmann

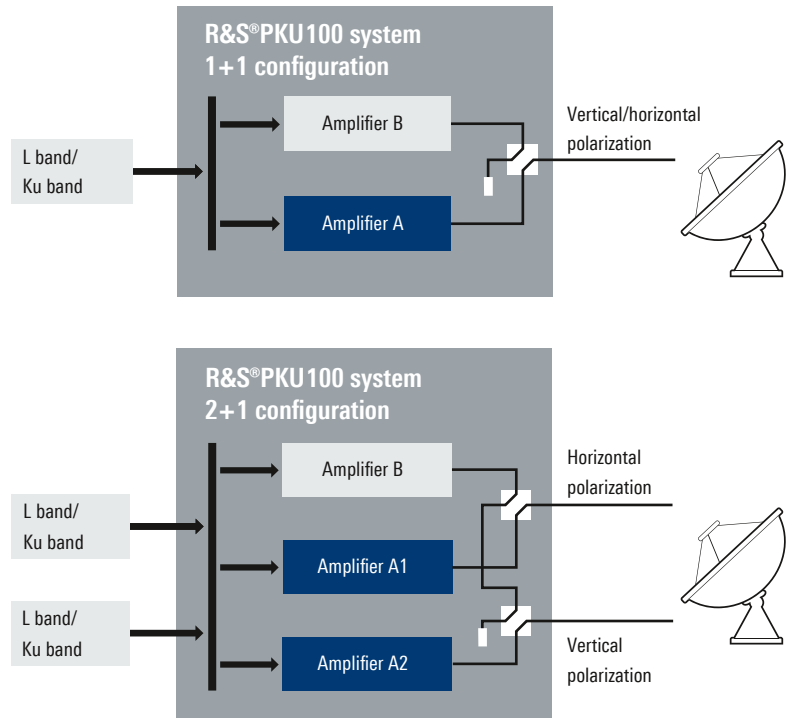

Fig. 3: In both 1+1 and 2+1 configurations, the integrated system controller of the R&S®PKU100 supersedes external monitoring and control equipment.



Fig. 4: Three R&S®PKU100 uplink amplifiers, configured as a 2+1 system, are managed by the integrated system control function. If an active amplifier fails, the backup unit takes over in a fraction of a second.



© scharfsm86 / stock.adobe.com

TROUBLEMAKER IN SIGHT!

The R&S®ARDRONIS drone warning and counter system is based on radiomonitoring, but it now also has a set of eyes to allow visual assessment of approaching drones.

Detection capabilities and countermeasures against commercial drones are now part of the standard repertoire of security authorities. Numerous incidents in recent years at airports and large events have put a spotlight on this important problem and led to the development of a variety of detection and interception solutions. The R&S®ARDRONIS system from Rohde&Schwarz is based on radiomonitoring. The advantage is that both the drone and the pilot can be located – as soon as the remote

control is switched on and even before the drone takes off. The drone type can also be identified based on the device's radio fingerprint. This helps assess the threat while simplifying the process of preserving evidence. RC signals are also used as a countermeasure against drones. Using a jamming signal that is precisely tailored to the specific drone type, the radio link to the remote control is interrupted through smart jamming. The device then switches to failsafe mode and either lands or

returns to the takeoff point. The latter option can be prevented by also jamming the GPS signal, causing the drone to lose orientation and land immediately. Despite the minimally invasive nature of these procedures, it should be obvious that only authorized authorities may be allowed to use them.

Until now, the R&S®ARDRONIS operator was only able to track a drone's trajectory on the displayed map or on a stored aerial or satellite image.



Fig. 1: The R&S®ARDN-PTC software extension enables control of motorized pan/tilt heads and cameras. Both camera models feature high zoom factors and built-in infrared spotlights for illuminating targets at night.

Fig. 2: One advantage of using radiomonitoring is the ability to locate the remote control and the drone pilot. R&S®ARDRONIS cameras use infrared optics to allow the drone pilot to be uncovered even at night.



Now, an additional real-time observation feature is available. The R&S®ARDN-PTC software option extends the system so it can control video cameras and directional antennas and automatically point them towards a detected target. Two different cameras are available. Both supply images in up to FHD resolution and operate in the visible spectrum as well as in the infrared range to support night operation. The gray camera (R&S®ARDN-PTZ; left in Fig. 1) is a useful addition to the R&S®ARDRONIS-D interception system (D = Direction). The black camera (R&S®ARDN-PTH) can be equipped with an R&S®HL040E directional antenna that rotates on both axes along with the camera in order to target the drone to be intercepted with the jamming signal. This option

is intended as an addition to the R&S®ARDRONIS-P system configuration (P = Protection). Both cameras feature the flying object in the image with high zoom factors and have a built-in infrared spotlight to illuminate targets at night (Fig. 2). Once automatic orientation is complete in a few seconds, the operator can use a joystick or mouse to continue the tracking process and vary the zoom factor as required. For better orientation, the current image section is marked in a 360° panoramic view of the surroundings (Fig. 3, right).

As a modular system, R&S®ARDRONIS can be flexibly adapted and scaled to handle the monitoring task at hand. Extended areas like airports require large-scale distribution of sensors and interception equipment. Cameras and jammers can be integrated into the system in the necessary quantity. R&S®ARDRONIS has an open system interface in order to allow integration into anti-drone systems that might include other sensor types such as radars and use robust interception techniques.

(Ed.)

Fig. 3: The R&S®ARDRONIS monitor screen shows all relevant information at a glance. Right: live image from the selected camera as well as location of the image section within the 360° panorama. Bottom: list of detected drones along with the drone and remote control positions on the aerial image.

