

# R&S®OSP OPEN SWITCH AND CONTROL PLATFORM

## Specifications



Specifications  
Version 12.01

**ROHDE & SCHWARZ**

Make ideas real



# CONTENTS

<b>Definitions .....</b>	<b>5</b>
<b>Notations and abbreviations .....</b>	<b>6</b>
<b>Introduction .....</b>	<b>6</b>
R&S®OSP220 .....	6
R&S®OSP230 .....	6
R&S®OSP320 .....	6
R&S®OSP-B200S2 .....	6
<b>General data .....</b>	<b>7</b>
R&S®OSP units .....	7
Module slots .....	8
Calibration interval .....	9
R&S®OSP-B200S2 satellite box .....	10
<b>Trigger option (R&amp;S®OSP-K100) .....</b>	<b>11</b>
Trigger types .....	11
Trigger interfaces .....	11
Trigger parameter .....	11
Trigger switching times $t_{TS}$ (typ.) .....	11
LAN and trigger operation and switching times of RF modules .....	12
<b>Overview of modules per frequency .....</b>	<b>13</b>
R&S®OSP modules with RF coaxial relays .....	13
<b>Overview of modules per function and frequency .....</b>	<b>14</b>
RF switch modules with electromechanical RF relays (EMR) .....	14
<i>DC to 12.4 GHz, relays with N connectors, non-terminated, failsafe .....</i>	<i>14</i>
<i>DC to 18 GHz, relays with SMA connectors, non-terminated, failsafe .....</i>	<i>15</i>
<i>DC to 18 GHz, relays with SMA connectors, non-terminated, latching .....</i>	<i>15</i>
<i>DC to 18 GHz, relays with SMA, terminated, failsafe .....</i>	<i>16</i>
<i>DC to 26.5 GHz, relays with SMA connectors (up to 26.5 GHz), non-terminated, failsafe .....</i>	<i>17</i>
<i>DC to 26.5 GHz, relays with SMA<sup>12</sup> connectors (up to 26.5 GHz), terminated, failsafe .....</i>	<i>17</i>
<i>DC to 40 GHz, relays with 2.92 mm connectors, non-terminated, failsafe .....</i>	<i>18</i>
<i>DC to 40 GHz, relays with 2.92 mm connectors, terminated, failsafe .....</i>	<i>18</i>
<i>DC to 50 GHz, relays with 2.4 mm connectors, non-terminated, failsafe .....</i>	<i>19</i>
<i>DC to 50 GHz, relays with 2.4 mm connectors, non-terminated, latching .....</i>	<i>19</i>
<i>DC to 50 GHz, relays with 2.4 mm connectors, terminated, failsafe .....</i>	<i>19</i>
<i>DC to 67 GHz, relays with 1.85 mm connectors, non-terminated .....</i>	<i>20</i>
<i>DC to 67 GHz, relays with 1.85 connectors, terminated, latching .....</i>	<i>20</i>
RF switch modules with solid-state relays (SSR) .....	21
Digital I/O and multiplexer modules .....	22
Auxiliary modules .....	22
Special control modules for RF test systems .....	22
Overview special modules for Rohde & Schwarz test systems .....	23
<b>Overview of modules per number – rules for integration .....</b>	<b>24</b>

<b>Module specifications</b> .....	<b>26</b>
Universal RF switch modules with electromechanical relays (EMR) .....	26
DC to 12.4 GHz, relays with N connectors, failsafe .....	26
R&S®OSP-B106 (mixed module with SPDT (N) and SPDT (BNC) relays) .....	26
R&S®OSP-B131/-B132/-B133/-B136 (SPDT, SP6T and DPDT).....	26
DC to 18 GHz, relays with SMA connectors, non-terminated .....	27
R&S®OSP-B101/-B101L/-B102/-B102L/-B116 (SPDT, DPDT, SP6T) .....	27
R&S®OSP-BM6n (mixed RF switch module 1 x SP6T, n x SPDT) .....	27
R&S®OSP-B119 (mixed RF switch module SP8T and 2 x SPDT) .....	28
DC to 18 GHz, relays with SMA connectors, terminated.....	28
R&S®OSP-B121/-B122 (SPDT, SP6T).....	28
R&S®OSP-B123/-B124 (mixed modules with SPDT and SP6T) .....	29
R&S®OSP-B125 (mixed module with SPDT and SP6T).....	29
R&S®OSP-B129 (mixed RF switch module, terminated SP8T and non-terminated SPDT) .....	29
DC to 26.5 GHz, relays with SMA connectors (up to 26.5 GHz), non-terminated.....	30
R&S®OSP-B111E/-B112E/-B116E/-B119E (SPDT, SP6T, DPDT, SP8T) .....	30
R&S®OSP-BM6nE (mixed RF switch modules 1 x SP6T, n x SPDT).....	30
DC to 26.5 GHz, relays with SMA connectors (up to 26.5 GHz), terminated .....	31
R&S®OSP-B121E/-B122E (SPDT, SP6T).....	31
R&S®OSP-B125E (mixed RF switch module, SPDT and SP6T).....	31
R&S®OSP-B129E (mixed RF switch module, 1 x SP8T and 2 x SPDT).....	32
R&S®OSP-B182E (SP6T).....	32
DC to 40 GHz, relays with 2.92 mm connectors, non-terminated .....	33
R&S®OSP-B111H/-B112H/-B116H (SPDT, SP6T, DPDT).....	33
R&S®OSP-BM6nH (mixed RF switch modules 1 x SP6T, n x SPDT).....	33
DC to 40 GHz, relays with 2.92 mm connectors, terminated .....	34
R&S®OSP-B121H/-B122H/-B125H (SPDT, SP6T) .....	34
DC to 50 GHz, relays with 2.4 mm connectors, non-terminated .....	35
R&S®OSP-B111U/-B112U/-B116U (SPDT, SP6T, DPDT).....	35
R&S®OSP-BM6nU (mixed RF switch module 1 x SP6T, n x SPDT) .....	35
R&S®OSP-B111UL/-B112UL (SPDT, SP6T), latching .....	36
DC to 50 GHz, relays with 2.4 mm connectors, terminated .....	36
R&S®OSP-B121U/-B122U (SPDT, SP6T).....	36
DC to 67 GHz, relays with 1.85 mm connectors, non-terminated .....	37
R&S®OSP-B111V (SPDT, failsafe)/-B111VL (SPDT, latching)/-B112V (SP6T, failsafe) .....	37
DC to 67 GHz, relays with 1.85 mm connectors, terminated .....	38
R&S®OSP-B121VL/-B122VL (SPDT, SP6T).....	38
Universal solid-state RF switch modules (SSR) .....	39
9 kHz to 6 GHz: R&S®OSP-B107 (SSR, reflective ), 9 kHz to 10 GHz: R&S®OSP-B127 and R&S®OSP-B128 (SSR, absorptive )	39
9 kHz to 8 GHz: R&S®OSP-B142 (power SSR 40 dBm, reflective or with external termination 30 dBm).....	40
9 kHz to 43.5 GHz: R&S®OSP-B162K (absorptive SPDT) 9 kHz to 43.5 GHz: R&S®OSP-B164K (absorptive SP4T) .....	41
Switching and settling time of RF relays .....	42
Auxiliary modules .....	43
9 kHz to 40 GHz: R&S®OSP-B171H digital RF attenuator.....	43

Digital I/O and multiplexer modules .....	44
<i>R&amp;S®OSP-B103 (16 x digital I/O module)</i> .....	44
<i>R&amp;S®OSP-B108 (multiplexer module, 6-channel, 4-wire)</i> .....	44
Components for system applications .....	45
<i>R&amp;S®OSP-B104 (EMS module with drivers for external power relays)</i> .....	45
<i>R&amp;S®OSP-B114 (EMS module with N relay for compact test systems)</i> .....	45
<i>R&amp;S®OSP-PM-I (passive module for integration of one power sensor)</i> .....	46
<i>R&amp;S®OSP-BCST module kit for R&amp;S®OSP320</i> .....	46
<i>R&amp;S®OSP-BL01 load unit, 2 RU</i> .....	46
Options for RF feedthroughs.....	47
<i>R&amp;S®OSP-B011 and R&amp;S®OSP-B012 module panels for RF feedthroughs</i> .....	47
<i>R&amp;S®OSP-Z010/-Z011/-Z012 (cable sets for the module panels)</i> .....	47
Accessories for the R&S®OSP-B200S2 satellite box.....	48
<i>R&amp;S®OSP-B200R remote control module</i> .....	48
<i>R&amp;S®OSP-B200P AC power supply</i> .....	48
<i>Connection cables between R&amp;S®OSP-B200R and R&amp;S®OSP-B200S</i> .....	48
<b>Ordering information .....</b>	<b>49</b>
R&S®OSP base units and satellite box .....	49
Options for R&S®OSP base units .....	49
Switch and control modules for R&S®OSP .....	49
RF feedthroughs for R&S®OSP base units.....	50
Accessories for R&S®OSP base units .....	51
Accessories for R&S®OSP modules .....	51
Accessories for R&S®OSP satellite box (R&S®OSP-B200S2).....	51
<i>Cables between R&amp;S®OSP-B200R and R&amp;S®OSP-B200S2</i> .....	51
Service options for R&S®OSP .....	52

# Definitions

## General

Product data applies under the following conditions:

- Three hours of storage at ambient temperature followed by 30 minutes of warm-up operation
- Specified environmental conditions met
- Recommended calibration interval adhered to
- All internal automatic adjustments performed, if applicable

## Specifications with limits

Represent warranted product performance by means of a range of values for the specified parameter. These specifications are marked with limiting symbols such as  $<$ ,  $\leq$ ,  $>$ ,  $\geq$ ,  $\pm$ , or descriptions such as maximum, limit of, minimum. Compliance is ensured by testing or is derived from the design. Test limits are narrowed by guard bands to take into account measurement uncertainties, drift and aging, if applicable.

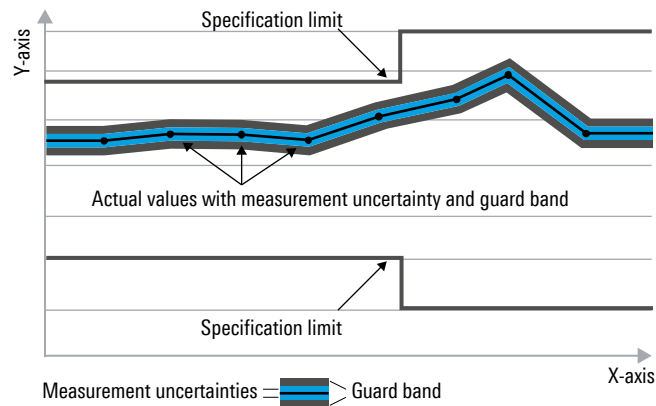

## Specifications without limits

Represent warranted product performance for the specified parameter. These specifications are not specially marked and represent values with no or negligible deviations from the given value (e.g. dimensions or resolution of a setting parameter). Compliance is ensured by design.

## Typical data (typ.)

Characterizes product performance by means of representative information for the given parameter. When marked with  $<$ ,  $>$  or as a range, it represents the performance met by approximately 80 % of the instruments at production time. Otherwise, it represents the mean value.

## Nominal values (nom.)

Characterize product performance by means of a representative value for the given parameter (e.g. nominal impedance). In contrast to typical data, a statistical evaluation does not take place and the parameter is not tested during production.

## Measured values (meas.)

Characterize expected product performance by means of measurement results gained from individual samples.

## Uncertainties

Represent limits of measurement uncertainty for a given measurand. Uncertainty is defined with a coverage factor of 2 and has been calculated in line with the rules of the Guide to the Expression of Uncertainty in Measurement (GUM), taking into account environmental conditions, aging, wear and tear.

Device settings and GUI parameters are indicated as follows: "parameter: value".

Typical data as well as nominal and measured values are not warranted by Rohde & Schwarz.

## Notations and abbreviations

The module name basically starts with R&S®OSP followed by a hyphen, the letter B and the particular type. For abbreviation, R&S®OSP can be omitted. For example, R&S®OSP-B111E is abbreviated as -B111E.

## Introduction

The R&S®OSP is a modular switch and control platform that enables you to perform RF switch and control tasks quickly. The flexibility of the R&S®OSP permits a broad scope of applications ranging from simple RF switch functions to RF wiring of complex systems such as EMC systems.

The following R&S®OSP models are available:

### R&S®OSP220

2 RU RF switch and control platform base unit controlled via LAN. It is designed for integration into a test setup as well as for automatic or manual control via a PC application. You can also operate the control platform using an external monitor and a USB keyboard.  
The R&S®OSP unit can be cascaded via LAN.  
The R&S®OSP220 has three module slots on the back and on the front of the instrument.



### R&S®OSP230

Manually operable 2 RU RF switch and control platform base unit featuring an integrated touchscreen. It can be used as a standalone, manually operated instrument, or it can be controlled via Ethernet interface in a system or test setup. This interface allows connection to a PC for automatic and manual control via a software application.  
The R&S®OSP unit can be cascaded via LAN.  
The R&S®OSP230 has three module slots on the back and two on the front of the instrument.



### R&S®OSP320

3 RU RF switch and control platform base unit controlled via LAN. It is designed for integration into a test setup as well as for automatic or manual control via a PC application. You can also operate the control platform using an external monitor and a USB keyboard.  
The R&S®OSP unit can be cascaded via LAN.  
The R&S®OSP320 has five module slots on the back and on the front of the instrument.

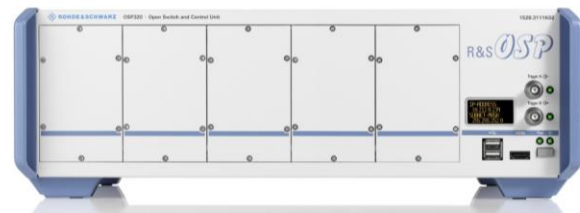

R&S®OSP320 with touchscreen option R&S®OSP-B300M and RF modules.

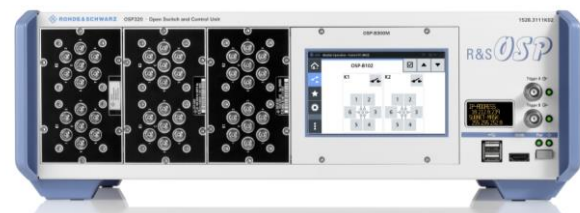

### R&S®OSP-B200S2

Satellite box for remote RF switch and control tasks via a serial electrical bus cable or a fiber-optic link (FOL).  
The R&S®OSP-B200S2 is controlled via the R&S®OSP-B200R remote control module, which can be installed in the R&S®OSP220, R&S®OSP230 or R&S®OSP320.  
The satellite box has two module slots with reduced depth.



# General data

## R&S®OSP units

		R&S®OSP220	R&S®OSP230	R&S®OSP320	
<b>Interfaces (front panel)</b>					
USB	for keyboard, mouse or USB stick	2	2	2	2 x USB 2.0, type A socket
HDMI™	for external monitor, resolution 800 x 480 pixel	1	1	1	HDMI™, type A socket
Touchscreen	for manual operation, resolution 800 x 400 pixel	–	1	1 <sup>1)</sup>	color
External trigger	input	1	1	1	BNC A with LED
	input and output (output function currently not active)	1	1	1	BNC B with LED
Status display	display of TCP/IP address	1	–	1	b/w
<b>Interfaces (rear panel)</b>					
USB		1	1	1	USB 3.0, type A socket
LAN	remote control via LAN	1	1	1	10/100/1000 Mbit/s Ethernet, RJ-45 socket
Protected memory slot	operating system	1	1	1	microSD card slot
Additional trigger interface	4 bit	–	–	1	D-Sub-9 male
<b>Environmental conditions</b>					
Temperature <sup>2</sup>	operating temperature range	0 °C to +50 °C			
	storage temperature range	–25 °C to +70 °C			
Damp heat		+40 °C, 90 % rel. humidity, constant, in line with EN 60068-2-30			
Height above zero		4600 m			
<b>Mechanical resistance</b>					
Vibration	sinusoidal	5 Hz to 55 Hz, 0.3 mm amplitude const., 55 Hz to 150 Hz, 0.5 g const., in line with EN 60068-2-6			
	random	8 Hz to 500 Hz, acceleration 1.2 g (RMS) in line with EN 60068-2-64			
Shock		40 g shock spectrum, in line with EN 60068-2-27, MIL-STD-810E, method no. 516.4, procedure I			
<b>Power supply</b>					
Rated voltage		100 V to 240 V AC (± 10 %)			
Rated frequency		50 Hz to 60 Hz (± 10 %)			
Maximum input power		1.5 A to 3.6 A (max. 310 VA)			
Rated power	without modules	< 25 W			
<b>Dimensions (W × H × D)</b>	R&S®OSP220, R&S®OSP230	444.7 mm × 107.6 mm × 471.9 mm (17.51 in × 4.24 in × 18.58 in)			
	for rackmounting (without modules)	1/1 19", 2 RU, depth 425 mm (16.73 in)			
	R&S®OSP320	444.7 mm × 152.05 mm × 471.9 mm (17.51 in × 5.99 in × 18.58 in)			
	for rackmounting (without modules)	1/1 19", 3 RU, depth 425 mm (16.73 in)			
<b>Weight</b>	R&S®OSP220 (without module)	approx. 6.85 kg (15.1 lb)			
	R&S®OSP230 (without module)	approx. 6.95 kg (15.3 lb)			
	R&S®OSP320 (without module)	approx. 7.95 kg (17.5 lb)			

<sup>1</sup> Optional, R&S®OSP-B300M touchscreen module.

<sup>2</sup> Temperature ranges apply to all base units and R&S®OSP modules (unless a different range is specified for the respective module).

Product conformity		
Electromagnetic compatibility	EU: EMC Directive 2014/30/EC	in line with EN 61326-1 (industrial environment), EN 61326-2-1, EN 55011 (class B)
Electrical safety	EU: Low Voltage Directive 2014/35/EC	in line with EN 61010-1, VDE certificate no.: 40022952
	USA/Canada	CAN 22.2 No. 61010-1-04, UL 61010-1, cCSA <sub>UL</sub> certificate no.: 1960595
RoHS	RoHS Directive 2011/65EC	in line with EN IEC 63000

## Module slots

Number of control buses for RF switch and control modules		16
Number of module slots	R&S®OSP220	3 on rear and 3 on front of instrument
	R&S®OSP230	3 on rear and 2 on front of instrument
	R&S®OSP320	5 on rear and 5 on front of instrument or 5 on rear and 3 on front of instrument and 2 slots for R&S®OSP-B300M touchscreen module
Output current	each control bus	max. 800 mA (+27 V DC)
	to all control buses	max. 10 A (+27 V DC)

Dimensions (W × H × D) of R&S®OSP220 and R&S®OSP230 module slots <sup>3</sup>		
Standard rear module slot	RS01	95.6 mm × 52.6 mm × max. 70 mm (3.76 in × 2.07 in × max. 2.76 in)
Standard front module slot	FS03 (not for R&S®OSP230)	95.6 mm × 52.6 mm × max. 70 mm (3.76 in × 2.07 in × max. 2.76 in)
Standard slots with higher depth	RS02, RS03, FS01, FS02	95.6 mm × 52.6 mm × max. 340 mm (3.76 in × 2.07 in × max. 13.38 in)
Double-width module slot	RS02 to RS03 and FS01 to FS02	204.2 mm × 52.6 mm × max. 340 mm (8.04 in × 2.07 in × max. 13.38 in)
Triple-width module slot	RS01 to RS03; FS01 to FS03 (not for R&S®OSP230)	312.8 mm × 52.6 mm × 70 mm, (12.31 in × 2.07 in × 2.76 in, depth: in parts 340 mm (13.38 in) (FS01 + FS02, RS02 + RS03)

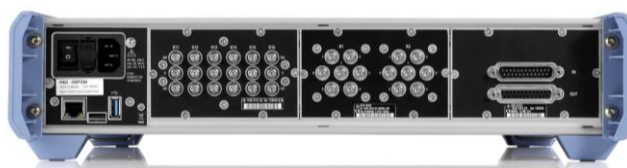

Rear view R&S®OSP220 and R&S®OSP230 units, rear module slots RS01 to RS03 (from left to right) with options

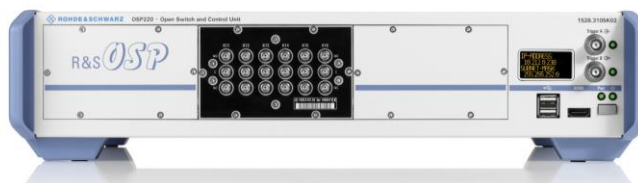

Front view R&S®OSP220, front module slots FS01 to FS03 (from left to right) with one option

<sup>3</sup> No restriction for standard modules on the opposite site.



Dimensions (W × H × D) of R&S®OSP320 <sup>3</sup>		
Module slot on the rear side	RS01	52.6 mm × 95.6 mm × max. 70 mm (2.07 in × 3.76 in × max. 2.76 in)
	RS02	52.6 mm × 95.6 mm × max. 130 mm (2.07 in × 3.76 in × max. 5.11 in)
	RS03 to RS05	52.6 mm × 95.6 mm × max. 340 mm (2.07 in × 3.76 in × max. 13.38 in)
Module slot on the front side	FS01 to FS03	52.6 mm × 95.6 mm × max. 340 mm (2.07 in × 3.76 in × max. 13.38 in)
	FS04, RS05	52.6 mm × 95.6 mm × max. 70 mm (2.07 in × 3.76 in × max. 2.76 in)

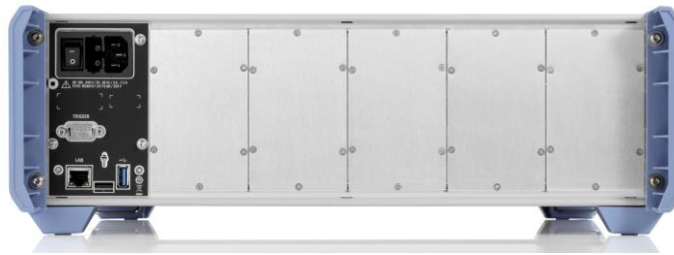

Rear view R&S®OSP320, rear module slots RS01 to RS05 (from left to right without options)

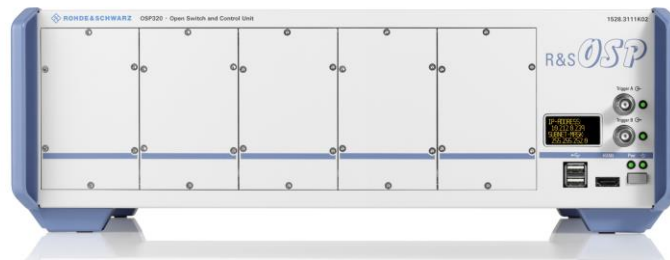

Front view R&S®OSP320, front module slots FS01 to FS05 (from left to right without options)

## Calibration interval<sup>4</sup>

R&S®OSP220, R&S®OSP230 and R&S®OSP320	without RF modules	no calibration necessary
	with RF modules	3 years or 50 % of switching cycles of the RF relays

<sup>4</sup> Recommended period. No calibration is needed when the R&S®OSP220/230/320 and RF modules are part of a system whose RF paths are regularly calibrated.

## R&S®OSP-B200S2 satellite box

Power supply	via R&S®OSP-B200P external power supply or wired link	28 V DC, input
Interface to remote control module	serial electrical bus (wired link) fiber-optic link (FOL), optional	1 x D-Sub-9 female connector 1 x SC female connector, simplex
Number of module slots		2 x simple-width, 1 x double-width
Number of module buses		2
Current consumption per module bus		max. 800 mA
Current consumption for both module buses	via serial electrical bus (wired link)	max. 1520 mA (+27 V DC)
	via external power supply (required for FOL)	max. 1600 mA (+28 V DC)
Status indication	power, link/busy, overheat	3 x LEDs
Environmental conditions, mechanical resistance, product conformity		see R&S®OSP base and extension units
Dimensions (W x H x D)	without edge protectors	241 mm x 84 mm x 120 mm (9.5 in x 3.3 in x 4.7 in)
	overall dimensions	265 mm x 109 mm x 150 mm (10.4 in x 4.3 in x 5.9 in)
Module slots (W x D)	simple width (slot A, slot B)	A: 95.6 mm x 105 mm (3.8 in x 4.1 in) B: 95.6 mm x 72 mm (3.8 in x 2.8 in)
	double width (slots A + B)	204.2 mm x 72 mm (8.0 in x 2.8 in)
Weight	without modules	approx. 1.05 kg (2.32 lb)



R&S®OSP-B200S2 front view (with options)



R&S®OSP-B200S2 rear view

# Trigger option (R&S® OSP-K100)

## Trigger types

Trigger type	R&S®OSP220	R&S®OSP230	R&S®OSP320	Description	Input
Single	•	•	•	after trigger event, the trigger mode will be deactivated (one of 16 paths)	via trigger input 1 (BNC A)
Toggle A-B	•	•	•	between two paths	via trigger input 1 (BNC A)
Sequenced	•	•	•	from path 0 to n (n = 2 to max. 15)	via trigger input 1 (BNC A), reset via trigger input BNC B
Addressed	– <sup>5</sup>	– <sup>5</sup>	•	direct trigger of addressed path (one of 16)	4 bits via D-Sub connector

## Trigger interfaces

Trigger interface	R&S®OSP220	R&S®OSP230	R&S®OSP320	Parameter	
Trigger input A and B (BNC on front panel)	•	•	•	input level range	0.5 V to 5 V
				max input current	0.1 A
				programmable trigger threshold	0.5 V to 4.95 V (226 steps)
				trigger signal width	min. 40 ns, edge-triggered
Address trigger input (4 bits, D-Sub connector on rear panel)	–	–	•	input level range	3.3 V LVTTTL logic, (5 V TTL logic tolerant)
				setup time	15 ns
				hold time	> 250 ns
				masked time until next trigger event	< 2.0 µs
				programmable trigger threshold	no

## Trigger parameter

Trigger processing time ( $t_{TP}$ ) (from trigger input to digital control signal for the R&S®OSP module)	R&S®OSP2x0, R&S®OSP320 ( $t_{Pint}$ )	< 1 µs
	R&S®OSP base unit and R&S®OSP satellite box (R&S®OSP-B200S2 via R&S®OSP-B200R), ( $t_{Pint} + t_{SD}$ )	< 2.8 µs
Trigger switching time ( $t_{TS}$ )	depends on switching element (digital outputs, relay type)	min. 1.2 µs <sup>6</sup>
Trigger interval ( $t_{Tim}$ )	BNC A (single trigger)	not applicable
	BNC A (toggle and sequenced trigger)	min. 2 µs (500 kHz) <sup>6</sup>
	D-Sub connector (addressed trigger)	min. 2 µs (500 kHz) <sup>6</sup>
Number of path registers	of OSP trigger unit, see trigger types	up to 16

## Trigger switching times $t_{TS}$ (typ.)<sup>7</sup>

Type of switching element	R&S®OSP module	Module in R&S®OSP base unit ( $t_{SD} = 0 \mu s$ )	Module in R&S®OSP satellite box
Modules with digital I/O	e.g. 16 outputs of R&S®OSP-B103	< 1.2 µs	< 3 µs
Modules with SSR	e.g. SPDT of R&S®OSP-B107/-B127	< 7 µs	< 9 µs
	e.g. SPDT of R&S®OSP-B142	< 8 µs	< 10 µs
Modules with electromechanical relays <sup>8</sup>	e.g. SPDT of R&S®OSP-B101/-B111x	< 10 ms	< 10 ms
	DPDT, SP6T, SP8T	< 15 ms	< 15 ms

<sup>5</sup> Only internal interface for addressed trigger.

<sup>6</sup> The achievable values depend on the relays used in the switching path, see trigger switching times in chapter Module specifications. If the switch module is located in the R&S®OSP-B200S2 satellite box the satellite delay time  $t_{SD}$  must be added.

<sup>7</sup> From trigger input to 90 % of final relay output signal. Refer to the specifications of the modules for certain trigger switching times.

<sup>8</sup> The delays of the internal trigger propagation times are not relevant (< 1 %). Therefore the rounded trigger switching time equals the relay switching time, independently from the position of the module.

## LAN and trigger operation and switching times of RF modules

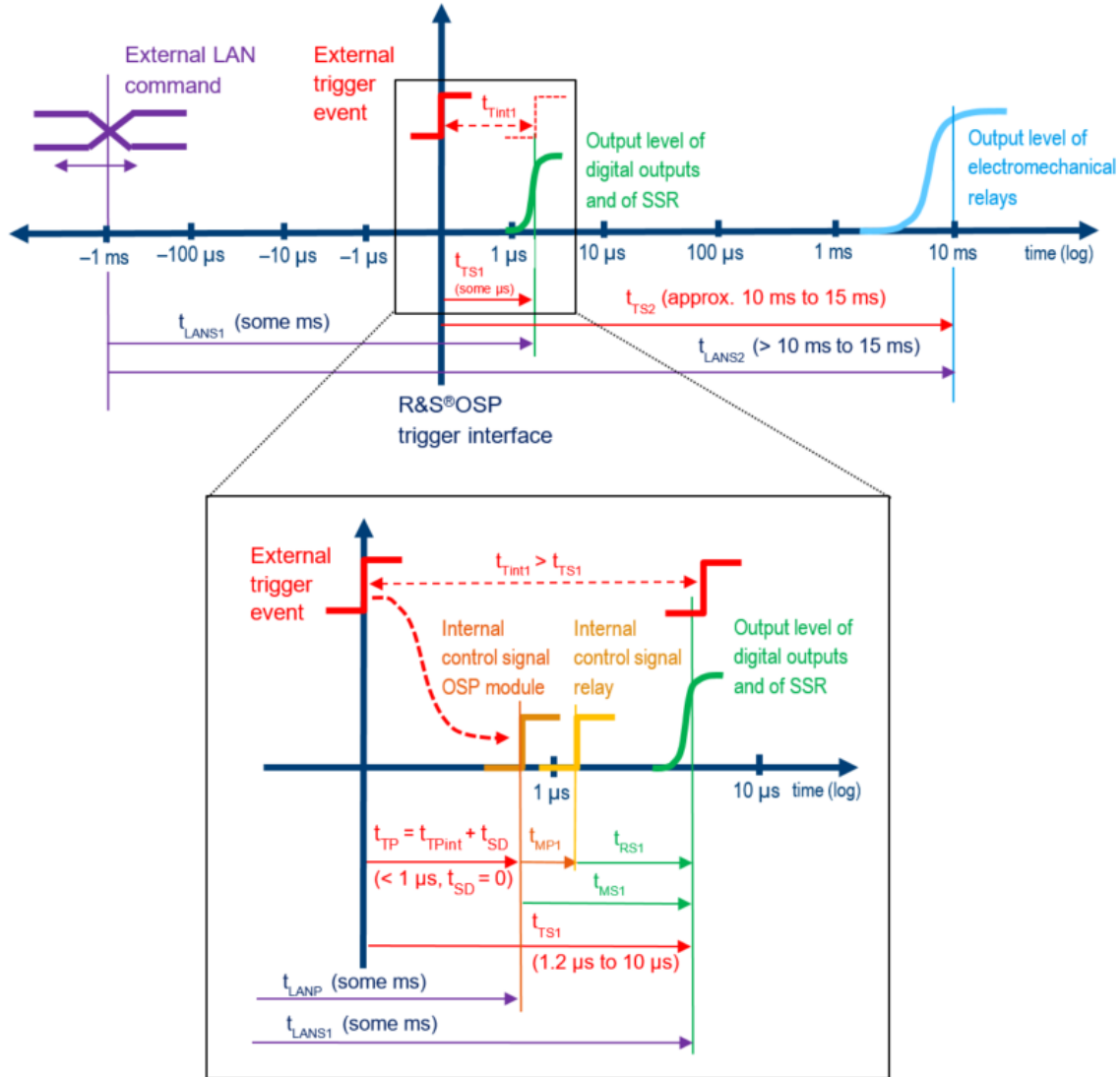

Trigger processing times as well as switching times of electromechanical coaxial relays and solid state relays

Dimension	Designation	Description
$t_{LANP}$	LAN processing time	propagation delay between SCPI command via LAN and control signal for the R&S®OSP module (including network latency time), typ. > 1 ms
$t_{LANS}$	LAN switching time	propagation delay between SCPI command via LAN and 90 % of final value at the relay
$t_{TS}$	trigger switching time ( $t_{TS} = t_{TP} + t_{MS}$ )	switching time between trigger signal and 90 % of final value at the relay
$t_{TP}$	trigger processing time ( $t_{TP} = t_{TPint} + t_{SD}$ )	internal propagation delay between trigger signal and control signal for the R&S®OSP module (including module in R&S®OSP satellite box)
$t_{TPint}$	internal trigger processing time	internal propagation delay of control signal between trigger and module of R&S®OSP (without R&S®OSP satellite box)
$t_{SD}$	satellite delay time	propagation delay of control signal between module control signal of R&S®OSP driver module and R&S®OSP satellite box
$t_{MS}$	module switching time ( $t_{MS} = t_{MP} + t_{RS}$ )	switching time between module signal and 90 % of final value at the relay
$t_{MP}$	module processing time	propagation delay of control signal between module and relay
$t_{RS}$	relay switching time	switching time between relay control signal and 90 % of final value at the relay
$t_{Tint}$	trigger interval (= 1/trigger frequency)	minimum time between trigger events (without guarantee of final value), the trigger interval should be larger than the trigger switching time ( $t_{Tint} \geq t_{TS}$ )

# Overview of modules per frequency <sup>9</sup>

## R&S<sup>®</sup>OSP modules with RF coaxial relays

Frequency range	0 Hz	9 kHz	to	6 GHz	8 GHz	10 GHz	12.4 GHz	18 GHz	26.5 GHz	40 GHz	43.5 GHz	50 GHz	67 GHz
Electro-mechanical RF relays	3 × SPDT (BNC, DC to 900 MHz) and 3 × SPDT (N), <a href="#">R&amp;S<sup>®</sup>OSP-B106</a>												
	2 × SPDT (N), <a href="#">R&amp;S<sup>®</sup>OSP-B131</a>												
	6 × SPDT (N), <a href="#">R&amp;S<sup>®</sup>OSP-B132</a>												
	1 × SP6T (N), <a href="#">R&amp;S<sup>®</sup>OSP-B133</a>												
	2 × DPDT (N), <a href="#">R&amp;S<sup>®</sup>OSP-B136</a>												
	6 × SPDT, <a href="#">R&amp;S<sup>®</sup>OSP-B101</a>												
	2 × SP6T, <a href="#">R&amp;S<sup>®</sup>OSP-B102</a>												
	1 × SP6T, n × SPDT, <a href="#">R&amp;S<sup>®</sup>OSP-BM6n</a> , n = 1 to 3												
	2 × DPDT, <a href="#">R&amp;S<sup>®</sup>OSP-B116</a>												
	1 × SP8T and 2 × SPDT, <a href="#">R&amp;S<sup>®</sup>OSP-B119</a>												
	6 × SPDT, latching, <a href="#">R&amp;S<sup>®</sup>OSP-B101L</a>												
	2 × SP6T, latching, <a href="#">R&amp;S<sup>®</sup>OSP-B102L</a>												
	3 × SPDT, terminated, <a href="#">R&amp;S<sup>®</sup>OSP-B121</a>												
	1 × SP6T, terminated, <a href="#">R&amp;S<sup>®</sup>OSP-B122</a>												
	6 × SPDT and 1 × SP6T, terminated, <a href="#">R&amp;S<sup>®</sup>OSP-B123</a>												
	3 × SPDT and 2 × SP6T, terminated, <a href="#">R&amp;S<sup>®</sup>OSP-B124</a>												
	6 × SPDT and 3 × SP6T, terminated, <a href="#">R&amp;S<sup>®</sup>OSP-B125</a>												
	1 × SP8T, terminated and 2 × SPDT, non-terminated, <a href="#">R&amp;S<sup>®</sup>OSP-B129</a>												
	6 × SPDT, <a href="#">R&amp;S<sup>®</sup>OSP-B111E</a>												
	n × SP6T, <a href="#">R&amp;S<sup>®</sup>OSP-B112E</a> , n = 1 or 2												
1 × SP6T, n × SPDT, <a href="#">R&amp;S<sup>®</sup>OSP-BM6nE</a> , n = 1 to 3													
2 × DPDT, <a href="#">R&amp;S<sup>®</sup>OSP-B116E</a>													
1 × SP8T and 2 × SPDT, <a href="#">R&amp;S<sup>®</sup>OSP-B119E</a>													
3 × SPDT, terminated, <a href="#">R&amp;S<sup>®</sup>OSP-B121E</a>													
1 × SP6T, terminated, <a href="#">R&amp;S<sup>®</sup>OSP-B122E</a>													
1 × SP6T, six connectors for external termination, <a href="#">R&amp;S<sup>®</sup>OSP-B182E</a>													
6 × SPDT and 3 × SP6T, terminated, <a href="#">R&amp;S<sup>®</sup>OSP-B125E</a>													
1 × SP8T, terminated and 2 × SPDT, non-terminated, <a href="#">R&amp;S<sup>®</sup>OSP-B129E</a>													
n × SPDT, <a href="#">R&amp;S<sup>®</sup>OSP-B111H</a> , n = 3 or 6													
n × SP6T, <a href="#">R&amp;S<sup>®</sup>OSP-B112H</a> , n = 1 or 2													
1 × SP6T, n × SPDT, <a href="#">R&amp;S<sup>®</sup>OSP-BM6nH</a> , n = 1 to 3													
2 × DPDT, <a href="#">R&amp;S<sup>®</sup>OSP-B116H</a>													
3 × SPDT, terminated, <a href="#">R&amp;S<sup>®</sup>OSP-B121H</a>													
1 × SPDT, terminated, <a href="#">R&amp;S<sup>®</sup>OSP-B122H</a>													
6 × SPDT and 3 × SP6T, terminated, <a href="#">R&amp;S<sup>®</sup>OSP-B125H</a>													
n × SPDT, <a href="#">R&amp;S<sup>®</sup>OSP-B111U</a> , n = 3 or 6													
n × SPDT, latching, <a href="#">R&amp;S<sup>®</sup>OSP-B111UL</a> , n = 3 or 6													
n × SP6T, <a href="#">R&amp;S<sup>®</sup>OSP-B112U</a> , n = 1 or 2													
1 × SP6T, latching, <a href="#">R&amp;S<sup>®</sup>OSP-B112UL</a>													
1 × SP6T, n × SPDT, <a href="#">R&amp;S<sup>®</sup>OSP-BM6nU</a> , n = 1 to 3													
n × DPDT, <a href="#">R&amp;S<sup>®</sup>OSP-B116U</a> , n = 1 or 2													
n × SPDT, terminated, <a href="#">R&amp;S<sup>®</sup>OSP-B121U</a> , n = 1 to 3													
1 × SP6T, terminated, <a href="#">R&amp;S<sup>®</sup>OSP-B122U</a>													
n × SPDT, <a href="#">R&amp;S<sup>®</sup>OSP-B111V</a> , n = 1 to 6													
n × SPDT, latching, <a href="#">R&amp;S<sup>®</sup>OSP-B111VL</a> , n = 3 or 6													
n × SP6T, <a href="#">R&amp;S<sup>®</sup>OSP-B112V</a> , n = 1 or 2													
n × SPDT, terminated, latching, <a href="#">R&amp;S<sup>®</sup>OSP-B121VL</a> , n = 1 to 3													
1 × SP6T, terminated, latching, <a href="#">R&amp;S<sup>®</sup>OSP-B122VL</a>													





<sup>9</sup> For further modules like digital I/O, multiplexer and system modules see page 22.

Frequency range	0 Hz	9 kHz	to	6 GHz	8 GHz	10 GHz	12.4 GHz	18 GHz	26.5 GHz	40 GHz	43.5 GHz	50 GHz	67 GHz
RF solid-state relays (SSR)		6 × SPDT, 30 dBm, <a href="#">R&amp;S®OSP-B107</a>											
		3 × DP3T, 40 dBm, reflective, <a href="#">R&amp;S®OSP-B142</a>											
		n × SPDT, 30 dBm, absorptive, <a href="#">R&amp;S®OSP-B142</a> , n = 1 to 3											
		6 × SPDT, 30 dBm, terminated, <a href="#">R&amp;S®OSP-B127</a>											
		n × SP6T, 30 dBm, terminated, <a href="#">R&amp;S®OSP-B128</a> , n = 1 to 3											
	n × SPDT, 23 dBm, terminated, <a href="#">R&amp;S®OSP-B162K</a> , n = 2, 4 or 6												
	n × SP4T, 23 dBm, terminated, <a href="#">R&amp;S®OSP-B164K</a> , n = 2, 3 or 4												

Note: Electromechanical RF relays are failsafe, non-terminated unless otherwise specified (e.g. latching, terminated).



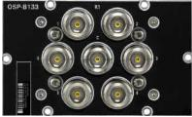

## Overview of modules per function and frequency





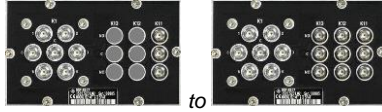
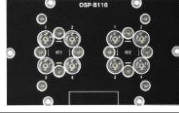
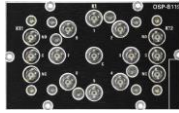
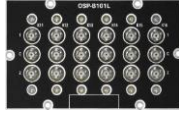

### RF switch modules with electromechanical RF relays (EMR) <sup>10</sup>

Type	Module designation	View of module width			Buses	Trigger switching time <sup>11</sup>	Page
		standard module	double-width module	triple-width module			
R&S®OSP							
<b>DC to 12.4 GHz, relays with N connectors, non-terminated, failsafe</b>							
-B106	RF switch module, 3 × coaxial changeover relays (SPDT), BNC female connector, DC to 900 MHz, 3 × coaxial changeover relays (SPDT), N female connector, DC to 12.4 GHz				1	15 ms	26
-B131	RF switch module, 2 × coaxial changeover relays (SPDT), N female connector, DC to 12.4 GHz				1	10 ms	26
-B132	RF switch module, 6 × coaxial changeover relays (SPDT), N female connector, DC to 12.4 GHz				2	10 ms	26
-B133	RF switch module, 1 × multiposition relays (SP6T), N female connector, DC to 12.4 GHz				1	15 ms	26
-B136	RF switch module, 2 × RF transfer relays (DPDT), N female connector, DC to 12.4 GHz				1	15 ms	26





<sup>10</sup> All relay modules contain failsafe (monostable) relays and SMA female connectors unless otherwise designated.

<sup>11</sup> Trigger switching time and trigger interval for the complete module. If only the faster relay of a module is switching the times can be shorter, see module parameter. For modules in the R&S®OSP satellite box the times are longer, see delay of the R&S®OSP-B200R remote control module.



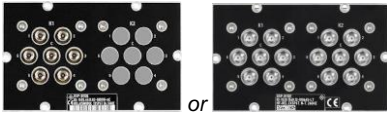
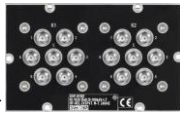

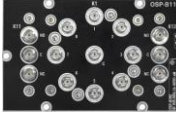
Type	Module designation	View of module width			Buses	Trigger switching time <sup>1)</sup>	Page
		standard module	double-width module	triple-width module			
R&S®OSP							
<b>DC to 18 GHz, relays with SMA connectors, non-terminated, failsafe</b>							
-B101	RF switch module, 6 × coaxial changeover relays (SPDT), DC to 18 GHz, non-terminated				1	10 ms	27
-B102	RF switch module, 2 × coaxial multiposition relays (SP6T), DC to 18 GHz, non-terminated				1	15 ms	27
-BM6n	RF switch module, 1 × coaxial multiposition relay (SP6T), non-terminated, 1 to 3 × coaxial changeover relays (SPDT), DC to 18 GHz, non-terminated				1	15 ms	27
-B116	RF switch module, 2 × RF transfer relays (DPDT), DC to 18 GHz, non-terminated				1	10 ms	27
-B119	RF switch module, 1 × coaxial multiposition relays (SP8T), non-terminated, 2 × coaxial changeover relays (SPDT), DC to 18 GHz, non-terminated				1	15 ms	28
<b>DC to 18 GHz, relays with SMA connectors, non-terminated, latching</b>							
-B101L	RF switch module, 6 × coaxial changeover relays (SPDT), DC to 18 GHz, non-terminated				1	10 ms	27
-B102L	RF switch module, 2 × coaxial multiposition relays (SP6T), DC to 18 GHz, non-terminated				1	–	27





Type	Module designation	View of module width			Buses	Trigger switching time <sup>1)</sup>	Page
		standard module	double-width module	triple-width module			
R&S®OSP							
<b>DC to 18 GHz, relays with SMA, terminated, failsafe</b>							
-B121	RF switch module, 3 × coaxial changeover relays (SPDT), SMA female connectors, DC to 18 GHz, internal termination				1	10 ms	28
-B122	RF switch module, 1 × coaxial multiposition relay (SP6T), SMA female connectors, DC to 18 GHz, internal termination				1	15 ms	28
-B123	RF switch module, 6 × coaxial changeover relays (SPDT), 1 × coaxial multiposition relays (SP6T), SMA female connectors, DC to 18 GHz, internal termination				2	15 ms	29
-B124	RF switch module, 3 × coaxial changeover relays (SPDT), 2 × coaxial multiposition relays (SP6T), SMA female connectors, DC to 18 GHz, internal termination				1	15 ms	29
-B125	RF switch module, 6 × coaxial changeover relays (SPDT), 3 × coaxial multiposition relays (SP6T), SMA female connectors, DC to 18 GHz, internal termination				2	15 ms	29
-B129	RF switch module, 1 × coaxial multiposition relays (SP8T), DC to 18 GHz, internal termination, 2 × coaxial changeover relays (SPDT), SMA female connectors, DC to 18 GHz, non-terminated				1	15 ms	29

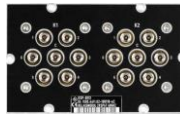
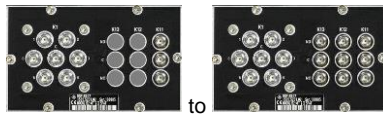
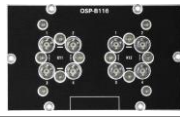

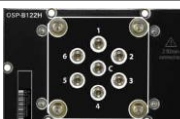
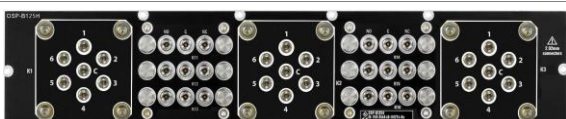

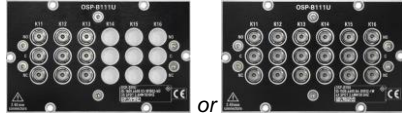
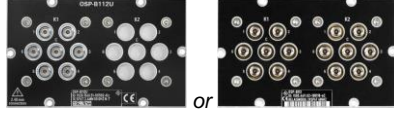
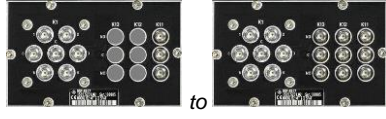
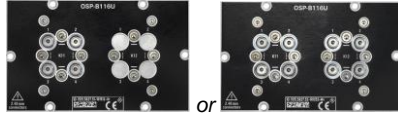
Type	Module designation	View of module width		Buses	Trigger switching time <sup>11</sup>	Page
		standard module	double-width module			
R&S®OSP						
<b>DC to 26.5 GHz, relays with SMA <sup>12</sup> connectors (up to 26.5 GHz), non-terminated, failsafe</b>						
-B111E	RF switch module, 6 × coaxial changeover relays (SPDT), SMA female connector, DC to 26.5 GHz, non-terminated			1	10 ms	30
-B112E	RF switch module, 1 or 2 × coaxial multiposition relays (SP6T), SMA female connector, DC to 26.5 GHz, non-terminated	 or 		1	15 ms	30
-BM6nE	RF switch module, 1 × coaxial multiposition relay (SP6T), non-terminated 1 to 3 × coaxial changeover relays (SPDT), DC to 26.5 GHz, non-terminated	 to 		1	15 ms	30
-B116E	RF switch module, 2 × RF transfer relays (DPDT), SMA female connector, DC to 26.5 GHz, non-terminated			1	15 ms	30
-B119E	RF switch module, 1 × coaxial multiposition relay (SP8T), 2 × coaxial changeover relays (SPDT), DC to 26.5 GHz, non-terminated			1	15 ms	30
<b>DC to 26.5 GHz, relays with SMA <sup>12</sup> connectors (up to 26.5 GHz), terminated, failsafe</b>						
-B121E	RF switch module, 3 × coaxial changeover relays (SPDT) with externally mounted terminations, SMA female connectors <sup>12</sup> , DC to 26.5 GHz, terminated			1	10 ms	31
-B122E	RF switch module, 1 × coaxial multiposition relay (SP6T), SMA female connectors <sup>12</sup> , DC to 26.5 GHz, internal termination			1	15 ms	31
-B125E	RF switch module, 6 × coaxial changeover relays (SPDT), 3 × coaxial multiposition relays (SP6T), SMA female connectors <sup>12</sup> , DC to 26.5 GHz, internal termination			2	15 ms	31
-B129E	RF switch module, 1 × coaxial multiposition relay (SP8T), DC to 26.5 GHz, internal termination, 2 × coaxial changeover relays (SPDT), SMA female connectors <sup>12</sup> , DC to 26.5 GHz, non-terminated			1	15 ms	32

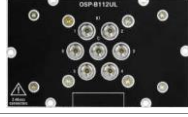



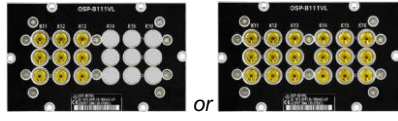
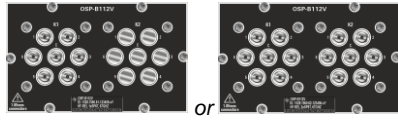

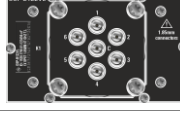
<sup>12</sup> SMA female connectors, compatible to RF cables with 3.5 mm and 2.92 mm male connectors.

Type	Module designation	View of module width			Buses	Trigger switching time <sup>11</sup>	Page
		standard module	double-width module	triple-width module			
R&S®OSP							
-B182E	RF switch module, 1 x coaxial multiposition relay (SP6T), SMA female connectors <sup>12</sup> , DC to 26.5 GHz, connectors for external termination				1	15 ms	32
<b>DC to 40 GHz, relays with 2.92 mm connectors, non-terminated, failsafe</b>							
-B111H	RF switch module, 3 or 6 x coaxial changeover relays (SPDT), 2.92 mm female connector, DC to 40 GHz, non-terminated				1	10 ms	33
-B112H	RF switch module, 1 or 2 x coaxial multiposition relays (SP6T), 2.92 mm female connector, DC to 40 GHz, non-terminated				1	15 ms	33
-BM6nH	RF switch module, 1 x coaxial multiposition relay (SP6T), non-terminated 1 to 3 x coaxial changeover relays (SPDT), non-terminated				1	15 ms	33
-B116H	RF switch module, 2 x RF transfer relays (DPDT), 2.92 mm female connector, DC to 40 GHz, non-terminated				1	15 ms	33
<b>DC to 40 GHz, relays with 2.92 mm connectors, terminated, failsafe</b>							
-B121H	RF switch module, 3 x coaxial changeover relays (SPDT), with externally mounted terminations, 2.92 mm female connectors, DC to 40 GHz				1	10 ms	34
-B122H	RF switch module, 1 x coaxial multiposition relay (SP6T), 2.92 mm female connectors, DC to 40 GHz, internal termination				1	15 ms	34
-B125H	RF switch module, 3 x coaxial changeover relays (SPDT), terminated (DP3T with external termination), 3 x coaxial multiposition relays (SP6T), 2.92 mm female connectors, DC to 40 GHz, internal termination				2	15 ms	34

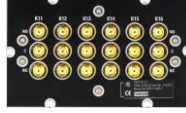

Type	Module designation	View of module width		Buses	Trigger switching time <sup>1)</sup>	Page
		standard module	double-width module			
R&S®OSP		triple-width module				
<b>DC to 50 GHz, relays with 2.4 mm connectors, non-terminated, failsafe</b>						
-B111U	RF switch module, 3 or 6 × coaxial changeover relays (SPDT), 2.4 mm female connectors, DC to 50 GHz, non-terminated,			1	10 ms	35
-B112U	RF switch module, 1 or 2 × coaxial multiposition relays (SP6T), 2.4 mm female connectors, DC to 50 GHz, non-terminated			1	15 ms	35
-BM6nU	RF switch module, 1 × coaxial multiposition relay, (SP6T), non-terminated 1 to 3 × coaxial changeover relays (SPDT), non-terminated				15 ms	35
-B116U	RF switch module, 1 or 2 × RF transfer relays (DPDT), 2.4 mm female connectors, DC to 50 GHz, non-terminated			1	15 ms	35
<b>DC to 50 GHz, relays with 2.4 mm connectors, non-terminated, latching</b>						
-B111UL	RF switch module, 3 or 6 × coaxial changeover relays (SPDT), 2.4 mm female connectors, DC to 50 GHz, non-terminated,			1	10 ms	36
-B112UL	RF switch module, 1 × coaxial multiposition relay (SP6T), 2.4 mm female connectors, DC to 50 GHz, non-terminated,			1	–	36
<b>DC to 50 GHz, relays with 2.4 mm connectors, terminated, failsafe</b>						
-B121U	RF switch module, 1, 2 or 3 × coaxial changeover relays (SPDT) with externally mounted terminations, 2.4 mm female connectors,			1	10 ms	36
-B122U	RF switch module, 1 × coaxial multiposition relay (SP6T), 2.4 mm female connectors, DC to 50 GHz, internal termination			1	15 ms	36

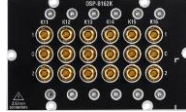
Type	Module designation	View of module width		Buses	Trigger switching time <sup>1)</sup>	Page
		standard module	double-width module			
R&S®OSP		triple-width module				
<b>DC to 67 GHz, relays with 1.85 mm connectors, non-terminated</b>						
-B111V	RF switch module, 1 to 6 x coaxial changeover relays (SPDT), 1.85 mm female connectors, DC to 67 GHz, non-terminated, failsafe	 <i>model .66</i>		1	10 ms	37
-B111VL	RF switch module, 3 or 6 x coaxial changeover relays (SPDT), 1.85 mm female connectors, DC to 67 GHz, non-terminated, latching	 <i>or</i>		1	15 ms	37
-B112V	RF switch module, 1 or 2 x coaxial multiposition relays (SP6T), 1.85 mm female connectors, DC to 67 GHz, non-terminated	 <i>or</i>		1	15 ms	37
<b>DC to 67 GHz, relays with 1.85 connectors, terminated, latching</b>						
-B121VL	RF switch module, 1, 2 or 3 x coaxial changeover relays (SPDT), 1.85 mm female connectors, internal termination			1	10 ms	38
-B122VL	RF switch module, 1 x coaxial multiposition relay (SP6T), 1.85 mm female connectors, DC to 67 GHz, internal termination			1	15 ms	38

## RF switch modules with solid-state relays (SSR)

Type	Module designation	View of module width		Buses	Trigger switching time <sup>1)</sup>	Page
		standard module	double-width module			
R&S®OSP						
-B107	RF switch module, 6 x coaxial changeover relays (SPDT), SSR, 9 kHz to 6 GHz, SMA, reflective (non-terminated)			1	10 μs	39
-B127	RF switch module, 6 x coaxial changeover relays (SPDT), SSR, 9 kHz to 10 GHz, SMA, absorptive (internal termination)			1	10 μs	39
-B128	RF switch module, 1 to 3 coaxial multiposition relays (SP6T), SSR, 9 kHz to 10 GHz, SMA, absorptive (internal termination)	 <i>model .13</i>		1	–	39
-B142	RF switch module, 3 x coaxial changeover relays DP3T reflective, power SSR 40 dBm, 9 kHz to 8 GHz, SMA; alternative models .11, .12, .13: 1 to 3 x SPDT, absorptive SSR, (reflective DP3T with external termination 30 dBm)	 <i>model .03</i>  <i>model .13 with external termination</i>		1	10 μs	40
-B162K	RF switch module, 2, 4 or 6 x coaxial changeover relays, absorptive power SSR 23 dBm, 9 kHz to 43.5 GHz, 2.92 mm	 <i>model .46</i>		1	8 μs	41
-B164K	RF switch module, 2, 3 or 4 x coaxial multiposition relays, SP4T absorptive power SSR 23 dBm, 9 kHz to 43.5 GHz, 2.92 mm	 <i>model .44</i>		1	8 μs	41





## Digital I/O and multiplexer modules

Type	Module designation	View of module width			Buses	Trigger switching time <sup>11</sup>	Page
		standard module	double-width module	triple-width module			
R&S®OSP							
-B103	digital I/O module, 16 × digital inputs, 16 × digital outputs				1	3 μs	44
-B108	multiplexer module, 6-channel, 4-wire multiplexer 0 V to 60 V, 30 VA				1	3 ms	44

## Auxiliary modules

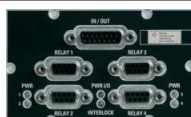







Type	Module designation	View of module width			Buses	Trigger switching time <sup>11</sup>	Page
		standard module	double-width module	triple-width module			
R&S®OSP							
-B171H	digital RF attenuator module, 2 or 4 × coaxial attenuators 9 kHz to 40 GHz, 2.92 mm	 model .44			1	100 μs	43

## Special control modules for RF test systems

Type	Module designation	View of module width			Buses	Trigger switching time <sup>11</sup>	Page
		standard module	double-width module	triple-width module			
R&S®OSP							
-B104	relay driver module, control of four external RF power relays, additional digital inputs/outputs, interlock				1	–	45
-B114	module for compact EMC test systems, RF relay (DPDT, failsafe), interlock, digital inputs/outputs				1	–	45
-B200R	remote control module for R&S®OSP-B200S2 satellite box; connection via copper cable or optionally via fiber-optic link (FOL)				up to 2	see t <sub>SD</sub> <sup>13</sup>	48
-PM-I	passive module for integration of one R&S®NRP power sensor (N feedthrough female connector and USB feedthrough filter)				–	–	46

<sup>13</sup> Additional delay time of maximum 1.8 μs for R&S®OSP modules inside the R&S®OSP satellite box, consisting of R&S®OSP-B200R and R&S®OSP-B200S2.

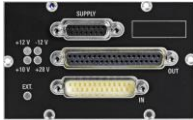
## Overview special modules for Rohde & Schwarz test systems <sup>14</sup>

Type	Module designation	View of module width	See document
R&S®OSP		standard module double-width module triple-width module	
-B151x	modules for R&S®TS8991 (OTA test system): <ul style="list-style-type: none"> <li>R&amp;S®OSP-B151, with basic OTA functionality</li> <li>R&amp;S®OSP-B151M, 2 x ampl.</li> <li>R&amp;S®OSP-B151S, 1 x ampl.</li> </ul>	 <p>R&amp;S®OSP-B151M</p>	3607.1242.32 (specifications)
-B153B	control module for separate relay and amplifier boxes of R&S®TS8991 OTA systems: TC-AZAMP67, TC-ELAMP67, TC-IFCON, TC-FCON75A/90A, TC-FC75T and R&S®TS8996 RSE systems: TS-PRE2, TC-RSExx, TC-MXxx, TC-RSEPOS		OTA specifications 3608.4151.22  RSE specifications 3609.9628.22
-B155G	module for R&S®TS8996 (RSE test system for 3G, LTE and 5G)		3609.9628.22 (specifications)
-B157W8 PLUS <sup>15</sup>	main module for R&S®TS8997 (synchronized multichannel high-resolution power meter and switching module)		5215.3085.22 (specifications)
-B157WX <sup>16</sup>	extension module for R&S®TS8997 (measurements relating to electromagnetic compatibility and radio spectrum matters (ERM) up to 40 GHz)		
-B157WN	extension module for R&S®TS8997 (automatic switching between conducted and normalized measurements for integral antenna equipment in a normalized test fixture)		
-B158	digital I/O module for AU600: <ul style="list-style-type: none"> <li>16 x digital inputs</li> <li>16 x RS-422 outputs</li> <li>4 x analog voltages</li> </ul>		4094.6061.02 AU600 manual
-BS016	antenna control module used for selecting the polarization and for activating or bypassing the amplifiers and power supplies of the following log-periodic antennas: <ul style="list-style-type: none"> <li>R&amp;S®HL024S2, R&amp;S®HL024S7</li> <li>R&amp;S®HL024S8, R&amp;S®HL024S9</li> <li>R&amp;S®HL050S7</li> <li>R&amp;S®HL007A2 via R&amp;S®ZS107</li> </ul>		3608.6602.22 (specifications)
-BS524	antenna control module used for TEMPEST measurements to select one of the following antennas: <ul style="list-style-type: none"> <li>R&amp;S®HE525, R&amp;S®HE526, R&amp;S®HE527</li> <li>R&amp;S®HL050S7</li> </ul>		

<sup>14</sup> System modules cannot be controlled by the trigger function of the R&S®OSP.

<sup>15</sup> R&S®OSP-B157W8 Plus for R&S®OSP150.

<sup>16</sup> R&S®OSP-B157WX for R&S®OSP120 or R&S®OSP220.

## Overview of modules per number – rules for integration <sup>17</sup>

Module name R&S®OSP	Order No.	Buses	No. of slots	Number of modules (front or rear side; front + rear side)				Opening of R&S®OSP is required	Page
				R&S®OSP220 max. 3 + 3	R&S®OSP230 max. 2 + 3	R&S®OSP320 max. 5 + 5	Satellite max. 2		
-B101	1505.5101.02	1	1	3 + 3	2 + 3	5 + 5	2	–	27
-B101L	1505.5101.52	1	1	3 + 3	2 + 3	5 + 5	2	–	27
-B102	1505.5201.02	1	1	3 + 3	2 + 3	5 + 5	2	–	27
-B102L	1505.5201.52	1	1	3 + 3	2 + 3	5 + 5	2	–	27
-B103	1505.5301.02	1	1	3 + 3	2 + 3	5 + 5	2	–	44
-B104	1505.5401.02	1	1	2 or 2; 1 + 1	2 or 2; 1 + 1	2 or 2; 1 + 1	–	•	45
-B106	1505.5601.02	1	2	1 + 1	1 + 1	–	–	•	26
-B107	1505.5901.02	1	1	3 + 3	2 + 3	5 + 5	2	–	39
-B108	1505.5718.02	1	1	3 + 3	2 + 3	5 + 5	2	–	44
-B111E	1505.4605.26	1	1	3 + 3	2 + 3	5 + 5	2	–	30
-B111H	1505.4605.4n	1	1	3 + 3	2 + 3	5 + 5	2	–	33
-B111U	1515.4605.5n	1	1	3 + 3	2 + 3	5 + 5	2	–	35
-B111UL	1528.1531.1n	1	1	3 + 3	2 + 3	5 + 5	2	–	36
-B111V	1528.4605.6n	1	1	3 + 3	2 + 3	5 + 5	2	–	37
-B111VL	1515.5991.1n	1	1	3 + 3	2 + 3	5 + 5	2	–	36
-B112E	1528.1560.1n	1	1	3 + 3	2 + 3	5 + 5	2	–	30
-B112H	1505.1560.4n	1	1	3 + 3	2 + 3	5 + 5	2	–	33
-B112U	1528.1560.5n	1	1	3 + 3	2 + 3	5 + 5	2	–	35
-B112UL	1528.1548.11	1	1	3 + 3	2 + 3	5 + 5	2	–	36
-B112V	1528.1560.6n	1	1	3 + 3	2 + 3	5 + 5	2	–	36
-BM6n	1528.1625.1n	1	1	3 + 3	2 + 3	5 + 5	2	–	27
-BM6nE	1528.1625.2n	1	1	3 + 3	2 + 3	5 + 5	2	–	30
-BM6nH	1528.1625.4n	1	1	3 + 3	2 + 3	5 + 5	2	–	33
-BM6nU	1528.1625.5n	1	1	3 + 3	2 + 3	5 + 5	2	–	35
-B114	1505.4711.02	1	1	3 + 3	2 + 3	5 + 5	2	–	45
-B116	1515.5827.02	1	1	3 + 3	2 + 3	5 + 5	2	–	27
-B116E	1528.5827.26	1	1	3 + 3	2 + 3	5 + 5	2	–	30
-B116H	1515.5827.40	1	1	3 + 3	2 + 3	5 + 5	2	–	33
-B116U	1515.5827.5n	1	1	3 + 3	2 + 3	5 + 5	2	–	35
-B119	1515.5856.02	1	1	3 + 3	2 + 3	4 + 4	2	–	28
-B119E	1515.5856.26	1	1	3 + 3	2 + 3	4 + 4	2	–	30
-B121	1515.5504.02	1	1	3 + 3	2 + 3	5 + 5	2	–	28
-B121E	1515.5504.26	1	1	3 + 3	2 + 3	5 + 5	2	–	31
-B121H	1515.5504.40	1	1	3 + 3	2 + 3	5 + 5	2	–	34
-B121U	1515.5504.5n	1	1	3 + 3	2 + 3	5 + 5	2	–	36
-B121VL	1515.5504.6n	1	1	3 + 3	2 + 3	5 + 5	2	–	38
-B122	1515.5510.02	1	1	3 + 3	2 + 3	4 + 4	2	–	28
-B122E	1515.1525.26	1	1	3 + 3	2 + 3	4 + 4	2	–	31
-B122H	1528.1525.02	1	1	3 + 3	2 + 3	4 + 4	2	–	34
-B122U	1528.1525.51	1	1	3 + 3	2 + 3	4 + 4	2	–	36
-B122VL	1528.1760.61	1	1	3 + 3	2 + 3	4 + 4	2	–	36
-B123	1515.5527.02	2	2	1 + 1	1 + 1	–	1	–	29
-B124	1515.5533.02	1	2	1 + 1	1 + 1	–	1	–	29
-B125	1515.5540.02	2	3	1 + 1	0 + 1	–	–	–	29
-B125E	1515.5540.26	2	3	1 + 1	0 + 1	–	–	–	31

<sup>17</sup> Restrictions are highlighted in light gray; combinations which are not possible are highlighted in dark gray.



Module name	Order No.	Buses	No. of slots	Number of modules (front or rear side; front + rear side)				Opening of R&S®OSP is required	Page
				R&S®OSP220 max. 3 + 3	R&S®OSP230 max. 2 + 3	R&S®OSP320 max. 5 + 5	Satellite max. 2		
R&S®OSP									
-B125H	1515.5540.40	2	3	1 + 1	0 + 1	–	–	–	34
-B127	1505.4728.02	1	1	3 + 3	2 + 3	5 + 5	2	–	39
-B128	1505.4734.1n	1	1	3 + 3	2 + 3	5 + 5	2	–	39
-B129	1517.7004.02	1	1	3 + 3	2 + 3	4 + 4	2	–	29
-B129E	1517.7004.26	1	1	3 + 3	2 + 3	4 + 4	2	–	32
-B131	1505.4740.02	1	1	3 + 3	2 + 3	5 + 5	2	–	26
-B132	1505.4757.02	2	2	1 + 1	1 + 1	–	1	–	26
-B133	1528.3157.02	1	1	3 + 3	2 + 3	4 + 4	2	–	26
-B136	1522.4500.02	1	1	3 + 3	2 + 3	5 + 5	2	–	26
-B142	1505.4792.03	1	1	3 + 3	2 + 3	5 + 5	2	–	40
	1505.4792.1n								
-B162K	1528.1677.4n	1	1	3 + 3	2 + 3	5 + 5	2	–	41
-B164K	1528.1660.4n	1	1	3 + 3	2 + 3	5 + 5	2	–	41
-B171H	1528.1577.4n	1	1	3 + 3	2 + 3	5 + 5	2	–	43
-B182E	1528.3263.21	1	1	3 + 3	2 + 3	4 + 4	2	–	32
-PM-I	1515.5985.02	–	1	2 + 2	2 + 2	3 + 3	–	–	46
<b>Remote control module for R&amp;S®OSP-B200S2 satellite box</b>									
-B200R	1528.3140.02	up to 2	1	3 + 3	2 + 3	5 + 5 (max. 8)	–	–	48
	1528.3140.04								
<b>Module panels for RF feedthroughs</b>									
-B011	1505.4763.02	–	1	3 + 3	2 + 3	5 + 5	–	•	47
-B012	1505.4770.02	–	1	3 + 3	2 + 3	5 + 5	–	•	47
<b>Special modules for Rohde &amp; Schwarz test systems</b>									
-B151x	see specifications of the test system	2	2	1	1	–	–	•	–
-B153B		1	1	3 + 3	2 + 3	5 + 5	2	–	–
-B155G		2	2	1	1	–	–	•	–
-B157W8 Plus <sup>15</sup>		–	2	–	–	–	–	•	–
-B157WX <sup>16</sup>		1	2	1	–	–	–	•	–
-B157WN		1	2	1	–	–	–	•	–
-B158		1	1	3 + 3	2 + 3	5 + 5	2	–	–
-BS016		2	2	1	1	–	–	•	–
-BS524		2	3	1	1	–	–	•	–
<b>Touchscreen module for R&amp;S®OSP320</b>									
-B300M	1528.3128.02	–	2	–	–	1	–	•	–

# Module specifications

## Universal RF switch modules with electromechanical relays (EMR)

DC to 12.4 GHz, relays with N connectors, failsafe

### R&S®OSP-B106 (mixed module with SPDT (N) and SPDT (BNC) relays)

Parameter	R&S®OSP-B106	
Number of relays	3 x SPDT with N female connector	3 x SPDT with BNC female connector
Relay type	coaxial relay	coaxial relay
Relay switching time (nom.) <sup>18</sup>	15 ms	3 ms
Trigger switching time	15 ms	3 ms
Relay impedance	50 Ω	
Current consumption	module, max. 600 mA (+27 V DC)	
Dimensions (W x H x D)	216.2 mm x 65.5 mm x 152.0 mm (8.51 in x 2.58 in x 5.98 in) double-width	
Slot position	with restrictions, see table rules for integration on page 24	
Weight	approx. 1.25 kg (2.75 lb)	

### RF characteristics

Type	Parameter	DC to 10 MHz	10 MHz to 100 MHz	100 MHz to 500 MHz	500 MHz to 900 MHz
SPDT, failsafe, BNC connector	VSWR	< 1.25	< 1.25	< 1.45	< 1.95
	insertion loss	< 0.5 dB	< 0.5 dB	< 1 dB	< 1.2 dB
	isolation	> 35 dB	> 35 dB	> 23 dB	> 15 dB
	average power	AC/RF <sup>21</sup> 60 W	60 W	40 W	20 W
	power	DC max. 60 W (max. 2 A, < 60 V)			
	number of switching cycles <sup>18</sup>	AC/RF (cold switching): 2 million; DC: 30 V/1 A, to max. 30 W: 0.5 million; 30 V/2 A, to max. 60 W: 0.1 million			
SPDT, failsafe, N connector		see SPDT R&S®OSP-B131			

### R&S®OSP-B131/-B132/-B133/-B136 (SPDT, SP6T and DPDT)

Parameter	R&S®OSP-B131	R&S®OSP-B132	R&S®OSP-B133	R&S®OSP-B136
Number of RF relays	2 x SPDT	6 x SPDT	1 x SP6T	2 x DPDT
Relay type	coaxial relays with N female connector			
Relay impedance	50 Ω			
Relays switching time	< 15 ms			
Trigger switching time	< 15 ms			
Current consumption (+27 V DC)	max. 300 mA	max. 900 mA	max. 190 mA	max. 300 mA
Dimensions (W x H x D)	107.6 x 65.5 x 85 mm (4.24 x 2.58 x 3.34 in)	216.2 x 65.5 x 84.5 mm (8.51 x 2.58 x 3.34 in)	107.6 x 65.5 x 87.8 mm (4.24 x 2.58 x 3.46 in)	107.6 x 65.5 x 87.8 mm (4.24 x 2.58 x 3.48 in)
	standard width	double-width	standard width	standard width
Dimension (D)	84.5 mm (3.27 in)	85 mm (3.35 in)	87.8 mm (3.46 in)	88.3 mm (3.48 in)
Slot position	without restrictions	with restrictions, see table on page 24	with restrictions, see table on page 24	without restrictions
Weight	approx. 0.40 kg (0.88 lb)	approx. 1.3 kg (2.87 lb)	approx. 0.50 kg (1.10 lb)	approx. 0.50 kg (1.10 lb)
Number of switching cycles <sup>18</sup>	1 million	1 million	2 million per position	2.5 million

### RF characteristics for R&S®OSP-B131, R&S®OSP-B132 and R&S®OSP-B136

Type	Parameter	DC to 1 GHz	1 GHz to 2 GHz	2 GHz to 3 GHz	3 GHz to 8 GHz	8 GHz to 12.4 GHz
SPDT/DPDT, failsafe	VSWR <sup>18</sup>	≤ 1.15	≤ 1.20	≤ 1.25	≤ 1.35	≤ 1.50
	insertion loss	< 0.35 dB/ ≤ 0.15 dB <sup>18</sup>	< 0.4 dB/ ≤ 0.20 dB <sup>18</sup>	< 0.4 dB/ ≤ 0.25 dB <sup>18</sup>	< 0.4 dB/ ≤ 0.35 dB <sup>18</sup>	< 0.5 dB/ ≤ 0.50 dB <sup>18</sup>
	isolation <sup>18</sup>	≥ 85 dB	≥ 80 dB	≥ 75 dB	≥ 70 dB	≥ 60 dB
	average power <sup>18, 21</sup>	700 W	500 W	400 W	250 W	200 W

**RF characteristics for R&S®OSP-B133**

Type	Parameter	DC to 1 GHz	1 GHz to 3 GHz	3 GHz to 8 GHz	8 GHz to 12.4 GHz
SP6T, failsafe (normally open)	VSWR <sup>18</sup>	≤ 1.20	≤ 1.20	≤ 1.35	≤ 1.50
	insertion loss	< 0.3 dB/ ≤ 0.20 dB <sup>18</sup>	< 0.3 dB/ ≤ 0.20 dB <sup>18</sup>	< 0.4 dB/ ≤ 0.35 dB <sup>18</sup>	< 0.6 dB/ ≤ 0.50 dB <sup>18</sup>
	isolation <sup>18</sup>	≥ 80 dB	≥ 80 dB	≥ 70 dB	≥ 60 dB
	average power <sup>18, 21</sup>	700 W	400 W	250 W	200 W

**DC to 18 GHz, relays with SMA connectors, non-terminated****R&S®OSP-B101/-B101L/-B102/-B102L/-B116 (SPDT, DPDT, SP6T)**

Parameter	R&S®OSP-B101	R&S®OSP-B101L	R&S®OSP-B102	R&S®OSP-B102L	R&S®OSP-B116
Number of relays	6 × SPDT		2 × SP6T		2 × DPDT
Relay type	failsafe	latching	failsafe (normally open)	latching	failsafe
	coaxial relay				
Connector type	SMA female				
Relay impedance	50 Ω				
Frequency range	DC to 18 GHz				
Relay switching time (nom.) <sup>18</sup>	< 10 ms		< 15 ms		< 15 ms
Trigger switching time	< 10 ms		< 15 ms	no	< 15 ms
Number of switching cycles <sup>18</sup>	10 million		5 million per position		2.5 million
Current consumption (module)	max. 600 mA (+27 V DC)	max. 480 mA (+27 V DC) <sup>19</sup>	max. 200 mA (+27 V DC)	max. 750 mA (+27 V DC) <sup>20</sup>	max. 300 mA (+27 V DC)
Dimensions (W × H)	107.6 mm × 65.5 mm (4.24 in × 2.58 in), standard width				
Dimension (D)	59.7 mm (2.35 in)	75.6 mm (2.89 in)	59.7 mm (2.35 in)	76.3 mm (3 in)	76.5 mm (3.01 in)
Slot position	without restrictions				
Weight	approx. 0.40 kg (0.88 lb)		approx. 0.50 kg (1.10 lb)		approx. 0.20 kg (0.44 lb)

**R&S®OSP-BM6n (mixed RF switch module 1 × SP6T, n × SPDT)**

Parameter	R&S®OSP-BM61	R&S®OSP-BM62	R&S®OSP-BM63
Number of relays	1 × SP6T, 1 × SPDT	1 × SP6T, 2 × SPDT	1 × SP6T, 3 × SPDT
Further relay parameter	SPDT, see R&S®OSP-B101; SP6T, see R&S®OSP-B102		
Current consumption (module)	max. 315 mA (+27 V DC)	max. 420 mA (+27 V DC)	max. 525 mA (+27 V DC)
Dimensions (W × H)	107.6 mm × 65.5 mm 4.24 in × 2.58 in), standard width		
Dimension (D)	72.3 mm (2.85 in)		
Slot position	without restrictions		
Weight	approx. 0.35 kg (0.77 lb)	approx. 0.40 kg (0.88 lb)	approx. 0.45 kg (0.99 lb)

**RF characteristics for R&S®OSP-B101/-B101L/-B102/-B102L/-B116 and R&S®OSP-BM6n**

Type	Parameter	DC to 3 GHz	3 GHz to 8 GHz	8 GHz to 12.4 GHz	12.4 GHz to 18 GHz
SPDT, DPDT, SP6T	VSWR <sup>18</sup>	≤ 1.20	≤ 1.30	≤ 1.40	≤ 1.50
	insertion loss	< 0.5 dB/ ≤ 0.20 dB <sup>18</sup>	< 0.5 dB/ ≤ 0.30 dB <sup>18</sup>	< 0.6 dB/ ≤ 0.40 dB <sup>18</sup>	< 0.7 dB/ ≤ 0.50 dB <sup>18</sup>
	isolation <sup>18</sup>	≥ 80 dB	≥ 70 dB	≥ 60 dB	≥ 60 dB
	average power <sup>18, 21</sup>	240 W	150 W	120 W	100 W

<sup>18</sup> Nominal values specified by the relay manufacturer at +25 °C.<sup>19</sup> Only during changeover.<sup>20</sup> Only during a reset.<sup>21</sup> Cold switching.

**R&S®OSP-B119 (mixed RF switch module SP8T and 2 × SPDT)**

Parameter	R&S®OSP-B119	
Number and type of relays	1 × SP8T (non-terminated)	2 × SPDT (non-terminated)
Relay type	coaxial relays, SMA female	
Relay impedance	50 Ω	
Frequency range	DC to 18 GHz	
Relay switching time (nom.)	SP8T: 15 ms	SPDT: 10 ms
Trigger switching time	SP8T: 15 ms	SPDT: 10 ms
Number of switching cycles <sup>18</sup>	2 million per position	5 million
Current consumption (module)	max. 300 mA (+27 V DC)	
Dimensions (W × H × D)	107.6 mm × 65.5 mm × 76.5 mm (4.24 in × 2.58 × 3.01 in)	
Slot position	with restrictions, see table rules for integration on page 24	
Weight	approx. 0.40 kg (0.88 lb)	

**RF characteristics**

Type	Parameter	DC to 3 GHz	3 GHz to 8 GHz	8 GHz to 12.4 GHz	12.4 GHz to 16 GHz	16 GHz to 18 GHz
SP8T failsafe (normally open)	VSWR <sup>18</sup>	≤ 1.20	≤ 1.30	≤ 1.40	≤ 1.50	≤ 1.60
	insertion loss	< 0.5 dB/ ≤ 0.20 dB <sup>18</sup>	< 0.5 dB/ ≤ 0.30 dB <sup>18</sup>	< 0.7 dB/ ≤ 0.40 dB <sup>18</sup>	< 0.7 dB/ ≤ 0.5 dB <sup>18</sup>	< 0.7 dB/ ≤ 0.5 dB <sup>18</sup>
	isolation <sup>18</sup>	≥ 80 dB	≥ 70 dB	≥ 60 dB	≥ 60 dB	≥ 60 dB
	average power <sup>18, 21</sup>	240 W	150 W	120 W	100 W	100 W
	number of switching cycles <sup>18</sup>	2 million per position				
SPDT failsafe		see SPDT relay of module R&S®OSP-B101				

**DC to 18 GHz, relays with SMA connectors, terminated****R&S®OSP-B121/-B122 (SPDT, SP6T)**

Parameter	R&S®OSP-B121	R&S®OSP-B122
Number and type of relays	3 × SPDT	1 × SP6T
Relay type	coaxial relays, SMA female	
Frequency range	DC to 18 GHz	
Relay impedance	50 Ω	
Termination impedance	50 Ω, 1 W per termination	
Maximum termination power per relay	1 W	3 W
Relay switching time (nom.)	10 ms	15 ms
Trigger switching time	10 ms	15 ms
Number of switch cycles	2 million	2 million per position
Current consumption (module)	max. 675 mA (+27 V DC)	max. 115 mA (+27 V DC)
Dimensions (W × H × D)	107.6 mm × 65.5 mm × 70.8 mm (4.23 in × 2.58 in × 2.79 in)	
Slot position	without restrictions	with restrictions, see table on page 24
Weight	approx. 0.40 kg (0.88 lb)	approx. 0.30 kg (0.66 lb)

**RF characteristics**

Type	Parameter	DC to 3 GHz	3 GHz to 8 GHz	8 GHz to 12.4 GHz	12.4 GHz to 18 GHz
SPDT, terminated, failsafe	VSWR <sup>18</sup>	≤ 1.20	≤ 1.30	≤ 1.40	≤ 1.50
	insertion loss	< 0.5 dB/ ≤ 0.20 dB <sup>18</sup>	< 0.5 dB/ ≤ 0.30 dB <sup>18</sup>	< 0.7 dB/ ≤ 0.40 dB <sup>18</sup>	< 0.7 dB/ ≤ 0.50 dB <sup>18</sup>
	isolation <sup>18</sup>	≥ 80 dB	≥ 70 dB	≥ 60 dB	≥ 60 dB
	average power <sup>18, 21</sup>	240 W	150 W	120 W	100 W
	number of switching cycles <sup>18</sup>	2 million			
SP6T, terminated, failsafe (normally open)	VSWR <sup>18</sup>	≤ 1.20	≤ 1.30	≤ 1.40	≤ 1.50
	insertion loss	< 0.5 dB/ ≤ 0.20 dB <sup>18</sup>	< 0.5 dB/ ≤ 0.30 dB <sup>18</sup>	< 0.7 dB/ ≤ 0.40 dB <sup>18</sup>	< 0.7 dB/ ≤ 0.50 dB <sup>18</sup>
	isolation <sup>18</sup>	≥ 80 dB	≥ 70 dB	≥ 60 dB	≥ 60 dB
	average power <sup>18, 21</sup>	240 W	150 W	120 W	100 W
	number of switching cycles <sup>18</sup>	2 million per position			

**R&S®OSP-B123/-B124 (mixed modules with SPDT and SP6T)**

Parameter	R&S®OSP-B123	R&S®OSP-B124
Number and type of relays	6 × SPDT, 1 × SP6T	3 × SPDT, 2 × SP6T
Relay type	SPDT: see R&S®OSP-B121, SP6T: see R&S®OSP-B122	
Current consumption (module)	max. 1460 mA (+27 V DC)	max. 900 mA (+27 V DC)
Dimensions (W × H × D)	216.2 mm × 65.5 mm × 70.8 mm (8.51 in × 2.58 in × 2.79 in) (double-width modules)	
Slot position	with restrictions, see table rules for integration on page 24	
Weight	approx. 0.90 kg (1.98 lb)	approx. 0.80 kg (1.76 lb)

**R&S®OSP-B125 (mixed module with SPDT and SP6T)**

Parameter	R&S®OSP-B125
Number and type of relays	6 × SPDT, 3 × SP6T
Relay type	SPDT: see R&S®OSP-B121, SP6T: see R&S®OSP-B122
Current consumption (module)	max. 1685 mA (+27 V DC)
Dimensions (W × H × D)	324.8 mm × 65.5 mm × 70.8 mm (12.79 in × 2.58 in × 2.79 in) (triple-width modules)
Slot position	with restrictions, see table rules for integration on page 24
Weight	approx. 1.4 kg (3.08 lb)

**R&S®OSP-B129 (mixed RF switch module, terminated SP8T and non-terminated SPDT)**

Parameter	R&S®OSP-B129	
Number and type of relays (type of termination)	1 × SP8T (terminated)	2 × SPDT (non-terminated)
Relay type	coaxial relay, SMA female	
Frequency range	DC to 18 GHz	
Relay impedance	50 Ω	
Maximum termination power	50 Ω, 1 W per termination	–
Maximum termination per relay	max. 3 W	–
Relay switching time (nom.) <sup>18</sup>	15 ms	10 ms
Trigger switching time	15 ms	10 ms
Current consumption (module)	max. 400 mA (+27 V DC)	
Dimensions (W × H × D)	107.6 mm × 65.5 mm × 70.8 mm (4.24 in × 2.58 in × 2.79 in), standard width	
Slot position	with restrictions, see table rules for integration on page 24	
Weight	approx. 0.40 kg (0.88 lb)	

**RF characteristics for R&S®OSP-B123/-B124, R&S®OSP-B125 and R&S®OSP-B129**

Type	Parameter	DC to 3 GHz	3 GHz to 8 GHz	8 GHz to 12.4 GHz	12.4 GHz to 16 GHz	16 GHz to 18 GHz
SP8T, failsafe (normally open)	VSWR <sup>18</sup>	≤ 1.20	≤ 1.30	≤ 1.40	≤ 1.50	≤ 1.60
	insertion loss	≤ 0.4 dB/ ≤ 0.20 dB <sup>18</sup>	< 0.5 dB/ ≤ 0.30 dB <sup>18</sup>	< 0.6 dB/ ≤ 0.4 dB <sup>18</sup>	< 0.7 dB/ ≤ 0.5 dB <sup>18</sup>	< 0.7 dB/ ≤ 0.5 dB <sup>18</sup>
	isolation <sup>18</sup>	≥ 80 dB	≥ 70 dB	≥ 60 dB	≥ 60 dB	≥ 60 dB
	average power <sup>18, 21</sup>	240 W	150 W	120 W	100 W	100 W
	number of switching cycles <sup>18</sup>	2 million per position				
SPDT, failsafe		see SPDT relay of module R&S®OSP-B101				

## DC to 26.5 GHz, relays with SMA connectors (up to 26.5 GHz), non-terminated

## R&amp;S®OSP-B111E/-B112E/-B116E/-B119E (SPDT, SP6T, DPDT, SP8T)

Parameter	R&S®OSP-B111E	R&S®OSP-B112E	R&S®OSP-B116E	R&S®OSP-B119E
Number of relays	6 x SPDT	1 or 2 x SP6T	2 x DPDT	1 x SP8T + 2 x SPDT
Relay type	coaxial relay			
Connector type	SMA female (up to 26.5 GHz), compatible to 3.5 mm and 2.92 mm RF cable			
Relay impedance	50 Ω			
Frequency range	DC to 26.5 GHz			
Relay switching time (nom.) <sup>18</sup>	< 10 ms	< 15 ms	< 15 ms	< 15 ms
Trigger switching time	< 10 ms	< 15 ms	< 15 ms	< 15 ms
Number of switching cycles <sup>18</sup>	5 million per position			
Current consumption (module) (+27 V DC)	max. 105 mA <sup>20</sup>	max. 105 mA or 210 mA <sup>20</sup>	max. 140 mA <sup>20</sup>	max. 315 mA <sup>20</sup>
Dimensions (W x H)	107.6 mm x 65.5 mm (4.24 in x 2.58 in), standard width			
Dimension (D)	69.2 mm (2.72 in)			
Slot position	without restrictions			
Weight	approx. 0.4 kg (0.88 lb)			

## R&amp;S®OSP-BM6nE (mixed RF switch modules 1 x SP6T, n x SPDT)

Parameter	R&S®OSP-BM61E	R&S®OSP-BM62E	R&S®OSP-BM63E
Number of relays	1 x SP6T, 1 x SPDT	1 x SP6T, 2 x SPDT	1 x SP6T, 3 x SPDT
Further relay parameters	SPDT: see R&S®OSP-B111E; SP6T: see R&S®OSP-B112E		
Current consumption (module)	max. 315 mA (+27 V DC)	max. 420 mA (+27 V DC)	max. 525 mA (+27 V DC)
Dimensions (W x H)	107.6 mm x 65.5 mm (4.24 in x 2.58 in), standard width		
Dimension (D)	72.3 mm (2.85 in)		
Slot position	without restrictions		
Weight	approx. 0.35 kg (0.77 lb)	approx. 0.40 kg (0.88 lb)	approx. 0.45 kg (0.99 lb)

## RF characteristics for R&amp;S®OSP-B111E/-B112E/-B116E/-B119E and R&amp;S®OSP-BM6nE

Type	Parameter	DC to 3 GHz	3 GHz to 8 GHz	8 GHz to 12.4 GHz	12.4 GHz to 18 GHz	18 GHz to 26.5 GHz
SPDT, failsafe	VSWR <sup>18</sup>	≤ 1.10	≤ 1.20	≤ 1.20	≤ 1.40	≤ 1.50
	insertion loss (in dB)	< 0.35/ ≤ 0.15 <sup>18</sup>	< 0.4/ ≤ 0.20 <sup>18</sup>	< 0.45/ ≤ 0.25 <sup>18</sup>	< 0.55/ ≤ 0.35 <sup>18</sup>	< 0.7/ ≤ 0.50 <sup>18</sup>
	isolation <sup>18</sup>	≥ 80 dB	≥ 75 dB	≥ 65 dB	≥ 60 dB	≥ 55 dB
	average power <sup>18, 21</sup>	240 W	150 W	120 W	100 W	40 W
SP6T, failsafe (normally open) and DPDT, failsafe	VSWR <sup>18</sup>	≤ 1.20	≤ 1.30	≤ 1.40	≤ 1.50	≤ 1.70
	insertion loss	< 0.4 dB/ ≤ 0.20 dB <sup>18</sup>	< 0.5 dB/ ≤ 0.30 dB <sup>18</sup>	< 0.6 dB/ ≤ 0.40 dB <sup>18</sup>	< 0.7 dB/ ≤ 0.50 dB <sup>18</sup>	< 0.9 dB/ ≤ 0.70 dB <sup>18</sup>
	isolation <sup>18</sup>	≥ 80 dB	≥ 70 dB	≥ 60 dB	≥ 60 dB	≥ 50 dB
	average power <sup>18, 21</sup>	240 W	150 W	120 W	100 W	40 W

Type	Parameter	DC to 3 GHz	3 GHz to 8 GHz	8 GHz to 12.4 GHz	12.4 GHz to 16 GHz	16 GHz to 18 GHz	18 GHz to 22 GHz	22 GHz to 26.5 GHz
SP8T, failsafe (normally open)	VSWR <sup>18</sup>	≤ 1.20	≤ 1.30	≤ 1.40	≤ 1.50	≤ 1.60	≤ 1.70	≤ 2.00
	insertion loss (in dB)	< 0.4/ ≤ 0.20 <sup>18</sup>	< 0.5/ ≤ 0.30 <sup>18</sup>	< 0.6/ ≤ 0.40 <sup>18</sup>	< 0.75/ ≤ 0.55 <sup>18</sup>	< 0.8/ ≤ 0.60 <sup>18</sup>	< 0.9/ ≤ 0.70 <sup>18</sup>	< 1.3/ ≤ 1.1 <sup>18</sup>
	isolation <sup>18</sup>	≥ 80 dB	≥ 70 dB	≥ 60 dB	≥ 60 dB	≥ 60 dB	≥ 60 dB	≥ 55 dB
	average power <sup>18, 21</sup>	240 W	150 W	120 W	110 W	100 W	90 W	40 W

## DC to 26.5 GHz, relays with SMA connectors (up to 26.5 GHz), terminated

## R&amp;S®OSP-B121E/-B122E (SPDT, SP6T)

Parameter	R&S®OSP-B121E	R&S®OSP-B122E
Number and type of relays	3 × SPDT, terminated (DP3T with external termination)	1 × SP6T, terminated
Relay type	coaxial relay, SMA female (up to 26.5 GHz) <sup>12</sup>	
Frequency range	DC to 26.5 GHz	
Relay impedance	50 Ω	
Termination impedance	50 Ω (ext.)	50 Ω (intern)
Maximum termination power	1 W, external termination	1 W per termination, 3 W per relay
Relays switching time (nom.) <sup>18</sup>	10 ms	15 ms
Trigger switching time	10 ms	15 ms
Number of switching cycles	2 million	2 million per position
Current consumption (module)	max. 675 mA (+27 V DC)	max. 120 mA (+27 V DC)
Dimensions (W × H × D)	107.6 mm × 65.5 mm × 88.0 mm (4.24 in × 2.58 in × 3.46 in)	107.6 mm × 65.5 mm × 79.4 mm (4.24 in × 2.58 in × 3.13 in)
Slot position	without restrictions	with restrictions, see table on page 24
Weight	approx. 0.35 kg (0.77 lb)	approx. 0.30 kg (0.66 lb)

## R&amp;S®OSP-B125E (mixed RF switch module, SPDT and SP6T)

Parameter	R&S®OSP-B125E
Number and type of relays	6 × SPDT, terminated (DP3T with external termination); 3 × SP6T, terminated
Further relay parameters	SPDT, see R&S®OSP-B121E; SP6T, see R&S®OSP-B122E
Current consumption (module)	max. 1685 mA (+27 V DC)
Dimensions (W × H × D)	324.8 mm × 65.5 mm × 70.8 mm (12.79 in × 2.58 in × 2.79 in) (triple-width module)
Slot position	with restrictions, see table rules for integration on page 24
Weight	approx. 1.4 kg (3.08 lb)

## RF characteristics for R&amp;S®OSP-B121E/-B122E and R&amp;S®OSP-B125E

Type	Parameter	DC to 3 GHz	3 GHz to 8 GHz	8 GHz to 12.4 GHz	12.4 GHz to 18 GHz	18 GHz to 26.5 GHz
SPDT, failsafe	VSWR <sup>18</sup>	≤ 1.20	≤ 1.30	≤ 1.40	≤ 1.50	≤ 1.70
	insertion loss	< 0.4 dB/ ≤ 0.20 dB <sup>18</sup>	< 0.5 dB/ ≤ 0.30 dB <sup>18</sup>	< 0.6 dB/ ≤ 0.40 dB <sup>18</sup>	< 0.7 dB/ ≤ 0.50 dB <sup>18</sup>	< 0.9 dB/ ≤ 0.70 dB <sup>18</sup>
	isolation <sup>18</sup>	≥ 80 dB	≥ 70 dB	≥ 60 dB	≥ 60 dB	≥ 55 dB
	average power <sup>18, 21</sup>	240 W	150 W	120 W	100 W	40 W
	number of switching cycles <sup>18</sup>	2 million				
SP6T, failsafe (normally open)	VSWR <sup>18</sup>	≤ 1.20	≤ 1.30	≤ 1.40	≤ 1.50	≤ 1.7/1.90 <sup>18</sup>
	insertion loss	< 0.4 dB/ ≤ 0.20 dB <sup>18</sup>	< 0.5 dB/ ≤ 0.30 dB <sup>18</sup>	< 0.6 dB/ ≤ 0.40 dB <sup>18</sup>	< 0.7 dB/ ≤ 0.50 dB <sup>18</sup>	< 0.9 dB/ ≤ 0.70 dB <sup>18</sup>
	isolation <sup>18</sup>	≥ 80 dB	≥ 70 dB	≥ 60 dB	≥ 60 dB	≥ 50 dB
	average power <sup>18, 21</sup>	240 W	150 W	120 W	100 W	40 W
	number of switching cycles <sup>18</sup>	2 million per position				

**R&S®OSP-B129E (mixed RF switch module, 1 × SP8T and 2 × SPDT)**

Parameter	R&S®OSP-B129E	
Number and type of relays	1 × SP8T (terminated)	2 × SPDT (non-terminated)
Relay type	coaxial relays, SMA female <sup>12</sup>	
Frequency range	DC to 26.5 GHz	
Relay impedance	50 Ω	
Termination impedance	50 Ω (internal)	–
Maximum termination power	1 W, internal termination, max. 3 W per relay	–
Relays switching time	15 ms	10 ms
Trigger switching time	15 ms	10 ms
Number of switching cycles	2 million per position	10 million cycles
Current consumption (module)	max. 515 mA (+27 V DC)	
Dimensions (W × H × D)	107.6 mm × 65.5 mm × 76.5 mm (4.24 in × 2.58 × 3.01 in)	
Slot position	with restrictions, see table rules for integration on page 24	
Weight	approx. 0.40 kg (0.88 lb)	

**RF characteristics for R&S®OSP-B129E**

Type	Parameter	DC to 3 GHz	3 GHz to 8 GHz	8 GHz to 12.4 GHz	12.4 GHz to 18 GHz	18 GHz to 26.5 GHz
SPDT, failsafe, non-terminated	VSWR <sup>18</sup>	≤ 1.10	≤ 1.20	≤ 1.20	≤ 1.40	≤ 1.50
	insertion loss	< 0.35 dB/ ≤ 0.15 dB <sup>18</sup>	< 0.40 dB/ ≤ 0.20 dB <sup>18</sup>	< 0.45 dB/ ≤ 0.25 dB <sup>18</sup>	< 0.65 dB/ ≤ 0.35 dB <sup>18</sup>	< 0.70 dB/ ≤ 0.50 dB <sup>18</sup>
	isolation <sup>18</sup>	≥ 80 dB	≥ 75 dB	≥ 65 dB	≥ 60 dB	≥ 55 dB
	average power <sup>18, 21</sup>	240 W	150 W	120 W	100 W	40 W

Type	Parameter	DC to 3 GHz	3 GHz to 8 GHz	8 GHz to 12.4 GHz	12.4 GHz to 16 GHz	16 GHz to 18 GHz	18 GHz to 22 GHz	22 GHz to 26.5 GHz
SP8T, failsafe (normally open), terminated	VSWR <sup>18</sup>	≤ 1.20	≤ 1.30	≤ 1.40	≤ 1.50	≤ 1.60	≤ 1.70	≤ 2.00
	insertion loss	< 0.40 dB/ ≤ 0.20 dB <sup>18</sup>	< 0.50 dB/ ≤ 0.30 dB <sup>18</sup>	< 0.60 dB/ ≤ 0.40 dB <sup>18</sup>	< 0.75 dB/ ≤ 0.55 dB <sup>18</sup>	< 0.80 dB/ ≤ 0.60 dB <sup>18</sup>	< 0.90 dB/ ≤ 0.70 dB <sup>18</sup>	< 1.30 dB/ ≤ 1.10 dB <sup>18</sup>
	isolation <sup>18</sup>	≥ 80 dB	≥ 70 dB	≥ 60 dB	≥ 60 dB	≥ 60 dB	≥ 60 dB	≥ 55 dB
	average power <sup>18, 21</sup>	240 W	150 W	120 W	110 W	100 W	90 W	40 W

**R&S®OSP-B182E (SP6T)**

Parameter	R&S®OSP-B182E
Number and type of relays	1 × SP6T, connectors for external termination
Relay type	coaxial relay, SMA female (up to 26.5 GHz) <sup>12</sup>
Frequency range	DC to 26.5 GHz
Relay impedance	50 Ω
Termination impedance	50 Ω
Maximum termination power	Depends on the connected load. Load is not part of delivery. Power capability is equal for switch and termination path. See also R&S®OSP-BL01 load unit on page 46.
Relays switching time (nom.) <sup>18</sup>	15 ms
Trigger switching time	15 ms
Number of switching cycles	3 million per position
Current consumption (module)	max. 120 mA (+27 V DC)
Dimensions (W × H × D)	107.6 mm × 65.5 mm × 79.4 mm (4.24 in × 2.58 in × 3.13 in)
Slot position	with restrictions, see table rules for integration on page 24
Weight	approx. 0.30 kg (0.66 lb)

**RF characteristics for R&S®OSP-B182E**

Type	Parameter	DC to 3 GHz	3 GHz to 8 GHz	8 GHz to 12.4 GHz	12.4 GHz to 18 GHz	18 GHz to 26.5 GHz
SP6T, failsafe (normally open)	VSWR <sup>18</sup>	≤ 1.20	≤ 1.30	≤ 1.40	≤ 1.50	≤ 1.70
	insertion loss	≤ 0.20 dB	≤ 0.30 dB	≤ 0.40 dB	≤ 0.50 dB	≤ 0.70 dB
	isolation <sup>18</sup>	≥ 80 dB	≥ 70 dB	≥ 60 dB	≥ 60 dB	≥ 50 dB
	average power <sup>18, 21</sup>	240 W	150 W	120 W	100 W	40 W
	number of switching cycles <sup>18</sup>	2 million per position				



**DC to 40 GHz, relays with 2.92 mm connectors, non-terminated****R&S®OSP-B111H/-B112H/-B116H (SPDT, SP6T, DPDT)**

Parameter	R&S®OSP-B111H	R&S®OSP-B112H	R&S®OSP-B116H
Relay type	6 × SPDT coaxial relay	2 × SP6T	2 × DPDT
Connector type	2.92 mm, K female		
Relay impedance	50 Ω		
Frequency range	DC to 40 GHz		
Relay switching time (nom.) <sup>18</sup>	< 10 ms	< 15 ms	< 15 ms
Trigger switching time	< 10 ms	< 15 ms	< 15 ms
Number of switching cycles <sup>18</sup>	5 million	2 million per position	2.5 million
Current consumption (module)	max. 600 mA (+27 V DC)	max. 200 mA (+27 V DC)	max. 300 mA (+27 V DC)
Dimensions (W × H)	107.6 mm × 65.5 mm (4.24 in × 2.58 in), standard width		
Dimension (D)	59.7 mm (2.35 in)	69.5 mm (2.74 in)	77.5 mm (3.05 in)
Slot position	without restrictions		
Weight	approx. 0.40 kg (0.88 lb)		

**R&S®OSP-BM6nH (mixed RF switch modules 1 × SP6T, n × SPDT)**

Parameter	R&S®OSP-BM61H	R&S®OSP-BM62H	R&S®OSP-BM63H
Number of relays	1 × SP6T, 1 × SPDT	1 × SP6T, 2 × SPDT	1 × SP6T, 3 × SPDT
Further relay parameters	SPDT, see R&S®OSP-B111H; SP6T, see R&S®OSP-B112H		
Current consumption (module)	max. 315 mA (+27 V DC)	max. 420 mA (+27 V DC)	max. 525 mA (+27 V DC)
Dimensions (W × H)	107.6 mm × 65.5 mm (4.24 in × 2.58 in), standard width		
Dimension (D)	72.3 mm (2.85 in)		
Slot position	without restrictions		
Weight	approx. 0.35 kg (0.77 lb)	approx. 0.40 kg (0.88 lb)	approx. 0.45 kg (0.99 lb)

**RF characteristics for R&S®OSP-B111H/-B112H/-B116H R&S®OSP-BM6nH**

Type	Parameter	DC to 6 GHz	6 GHz to 12.4 GHz	12.4 GHz to 18 GHz	18 GHz to 26.5 GHz	26.5 GHz to 40 GHz
SPDT, DPDT, failsafe	VSWR <sup>18</sup>	≤ 1.30	≤ 1.40	≤ 1.50	≤ 1.70	≤ 1.90
	insertion loss	< 0.5 dB/ ≤ 0.30 dB <sup>18</sup>	< 0.6 dB/ ≤ 0.40 dB <sup>18</sup>	< 0.7 dB/ ≤ 0.50 dB <sup>18</sup>	< 0.9 dB/ ≤ 0.70 dB <sup>18</sup>	< 1.0 dB/ ≤ 0.80 dB <sup>18</sup>
	isolation <sup>18</sup>	≥ 70 dB	≥ 60 dB	≥ 60 dB	≥ 55 dB	≥ 50 dB
	average power <sup>18, 21</sup>	SPDT DPDT	80 W	60 W	50 W	30 W 20 W
SP6T, failsafe (normally open)	VSWR <sup>18</sup>	≤ 1.30	≤ 1.40	≤ 1.50	≤ 1.70	≤ 2.20
	insertion loss	< 0.3 dB/ ≤ 0.20 dB <sup>18</sup>	< 0.5 dB/ ≤ 0.40 dB <sup>18</sup>	< 0.6 dB/ ≤ 0.50 dB <sup>18</sup>	< 0.8 dB/ ≤ 0.70 dB <sup>18</sup>	< 1.1 dB/ ≤ 1.0 dB <sup>18</sup>
	isolation <sup>18</sup>	≥ 70 dB	≥ 60 dB	≥ 60 dB	≥ 55 dB	≥ 50 dB
	average power <sup>18, 21</sup>	40 W	30 W	25 W	15 W	5 W

## DC to 40 GHz, relays with 2.92 mm connectors, terminated

## R&amp;S®OSP-B121H/-B122H/-B125H (SPDT, SP6T)

Parameter	R&S®OSP-B121H	R&S®OSP-B122H
Number and type of relays	3 × SPDT, terminated (DP3T with external termination)	1 × SP6T, terminated
Relay type	coaxial relay, 2.92 mm; K female	
Frequency range	DC to 40 GHz	
Relay impedance	50 Ω	
Termination impedance	50 Ω (ext.)	50 Ω (intern)
Maximum termination power	1 W per termination	1 W per termination, 3 W per relay
Relay switching time (nom.) <sup>18</sup>	10 ms	15 ms
Trigger switching time	10 ms	15 ms
Number of switching cycles	2 million	2 million per position
Current consumption (module)	max. 675 mA (+27 V DC)	max. 120 mA (+27 V DC)
Dimensions (W × H × D)	107.6 mm × 65.5 mm × 88.0 mm (4.24 in × 2.58 in × 3.46 in)	107.6 mm × 65.5 mm × 79.4 mm (4.24 in × 2.58 in × 3.13 in)
Slot position	without restrictions	with restrictions, see table on page 24
Weight	approx. 0.35 kg (0.77 lb)	approx. 0.30 kg (0.66 lb)

Parameter	R&S®OSP-B125H
Number and type of relays	6 × SPDT, terminated (DP3T with external termination), 3 × SP6T, terminated
Relay type	coaxial relays, 2.92 mm female
Frequency range	DC to 40 GHz
Relay impedance	50 Ω
Termination impedance	50 Ω, 1 W per termination
Maximum termination power per relay	SPDT: 1 W, SP6T: 3 W
Switching time (nom.)	SPDT: 10 ms, SP6T: 15 ms
Current consumption (module)	max. 1685 mA (+27 V DC)
Dimensions (W × H × D)	324.8 mm × 65.5 mm × 70.8 mm (12.79 in × 2.58 in × 2.79 in)
Slot position	with restrictions, see table rules for integration on page 24
Weight	approx. 1.4 kg (3.08 lb)

## RF characteristics

Type	Parameter	DC to 6 GHz	6 GHz to 12.4 GHz	12.4 GHz to 18 GHz	18 GHz to 26.5 GHz	26.5 GHz to 40 GHz
SPDT, failsafe, external terminated	VSWR <sup>18</sup>	≤ 1.30	≤ 1.40	≤ 1.50	≤ 1.90	≤ 2.3
	insertion loss	< 0.5 dB/ ≤ 0.30 dB <sup>18</sup>	< 0.7 dB/ ≤ 0.40 dB <sup>18</sup>	< 0.7 dB/ ≤ 0.50 dB <sup>18</sup>	< 1.0 dB/ ≤ 0.70 dB <sup>18</sup>	< 1.0 dB/ ≤ 0.80 dB <sup>18</sup>
	isolation <sup>18</sup>	≥ 70 dB	≥ 60 dB	≥ 60 dB	≥ 55 dB	≥ 50 dB
	average power <sup>21</sup>	80 W	60 W	50 W	20 W	10 W
	number of switching cycles <sup>18</sup>	2 million				
SP6T, failsafe (normally open), terminated	VSWR <sup>18</sup>	≤ 1.30	≤ 1.40	≤ 1.50	≤ 1.70	≤ 2.20
	insertion loss	< 0.5 dB/ ≤ 0.20 dB <sup>18</sup>	< 0.7 dB/ ≤ 0.40 dB <sup>18</sup>	< 0.7 dB/ ≤ 0.50 dB <sup>18</sup>	< 1.0 dB/ ≤ 0.70 dB <sup>18</sup>	< 1.3 dB/ ≤ 1.10 dB <sup>18</sup>
	isolation <sup>18</sup>	≥ 70 dB	≥ 60 dB	≥ 60 dB	≥ 55 dB	≥ 50 dB
	average power <sup>18, 21</sup>	40 W	30 W	25 W	15 W	5 W
	number of switching cycles <sup>18</sup>	2 million per position				

## DC to 50 GHz, relays with 2.4 mm connectors, non-terminated

## R&amp;S®OSP-B111U/-B112U/-B116U (SPDT, SP6T, DPDT)

Parameter	R&S®OSP-B111U	R&S®OSP-B112U	R&S®OSP-B116U
Relay type	3 or 6 × SPDT coaxial relay	1 or 2 × SP6T	1 or 2 × DPDT
Connector type	2.4 mm female		
Relay impedance	50 Ω		
Frequency range	DC to 50 GHz		
Relay switching time (nom.) <sup>18</sup>	< 10 ms	< 15 ms	< 15 ms
Trigger switching time	< 10 ms	< 15 ms	< 15 ms
Number of switching cycles <sup>18</sup>	2 million	2 million per position	2 million
Current consumption (module)	max. 105 mA or 210 mA (+27 V DC)	max. 105 mA or 210 mA (+27 V DC)	max. 140 mA or 280 mA (+27 V DC)
Dimensions (W × H)	107.6 mm × 65.5 mm (4.24 in × 2.58 in), standard width		
Dimension (D)	75 mm (2.95 in)	69.2 mm (2.72 in)	
Slot position	without restrictions		
Weight	approx. 0.40 kg (0.88 lb)		

## R&amp;S®OSP-BM6nU (mixed RF switch module 1 × SP6T, n × SPDT)

Parameter	R&S®OSP-BM61U	R&S®OSP-BM62U	R&S®OSP-BM63U
Number of relays	1 × SP6T, 1 × SPDT	1 × SP6T, 2 × SPDT	1 × SP6T, 3 × SPDT
Further relay parameter	SPDT, see R&S®OSP-B111U; SP6T, see R&S®OSP-B112U		
Current consumption (module)	max. 315 mA (+27 V DC)	max. 420 mA (+27 V DC)	max. 525 mA (+27 V DC)
Dimensions (W × H)	107.6 mm × 65.5 mm (4.24 in × 2.58 in), standard width		
Dimension (D)	72.3 mm (2.85 in)		
Slot position	without restrictions		
Weight	approx. 0.35 kg (0.77 lb)	approx. 0.40 kg (0.88 lb)	approx. 0.45 kg (0.99 lb)

## RF characteristics for R&amp;S®OSP-B111U/-B112U/-B116U and R&amp;S®OSP-BM6nU

Type	Parameter	DC to 6 GHz	6 GHz to 12.4 GHz	12.4 GHz to 18 GHz	18 GHz to 26.5 GHz	26.5 GHz to 40 GHz	40 GHz to 50 GHz
SPDT/DPDT, failsafe	VSWR <sup>18</sup>	≤ 1.30	≤ 1.40	≤ 1.50	≤ 1.70	≤ 1.90	≤ 1.90
	insertion loss	< 0.5 dB/ ≤ 0.30 dB <sup>18</sup>	< 0.6 dB/ ≤ 0.40 dB <sup>18</sup>	< 0.7 dB/ ≤ 0.50 dB <sup>18</sup>	< 0.9 dB/ ≤ 0.70 dB <sup>18</sup>	< 1.0 dB/ ≤ 0.80 dB <sup>18</sup>	< 1.3 dB/ ≤ 1.10 dB <sup>18</sup>
	isolation <sup>18</sup>	≥ 70 dB	≥ 60 dB	≥ 60 dB	≥ 55 dB	≥ 50 dB	≥ 50 dB
	average power <sup>18,21</sup>	80 W	60 W	50 W	20 W	10 W	5 W
SP6T, failsafe (normally open)	VSWR <sup>18</sup>	≤ 1.30	≤ 1.40	≤ 1.50	≤ 1.70	≤ 1.90	≤ 2.20
	insertion loss	< 0.4 dB/ ≤ 0.20 dB <sup>18</sup>	< 0.6 dB/ ≤ 0.40 dB <sup>18</sup>	< 0.7 dB/ ≤ 0.50 dB <sup>18</sup>	< 0.9 dB/ ≤ 0.70 dB <sup>18</sup>	< 1.1 dB/ ≤ 0.90 dB <sup>18</sup>	< 1.4 dB/ ≤ 1.20 dB <sup>18</sup>
	isolation <sup>18</sup>	≥ 70 dB	≥ 60 dB	≥ 60 dB	≥ 55 dB	≥ 50 dB	≥ 50 dB
	average power <sup>18,21</sup>	40 W	30 W	25 W	15 W	5 W	3 W

**R&S®OSP-B111UL/-B112UL (SPDT, SP6T), latching**

Parameter	R&S®OSP-B111UL	R&S®OSP-B112UL
Relay type	3 or 6 × SPDT, coaxial relay	1 × SP6T, coaxial relay
Connector type	2.4 mm female	
Relay impedance	50 Ω	
Frequency range	DC to 50 GHz	
Switching time (nom.) <sup>18</sup>	< 10 ms	< 40 ms
Number of switching cycles <sup>18</sup>	2 million	2 million per position
Current consumption (module)	3 relays: max. 240 mA or 480 mA <sup>19</sup> (+27 V DC)	max. 750 mA <sup>20</sup> (+27 V DC)
Dimensions (W × H)	107.6 mm × 65.5 mm (4.24 in × 2.58 in), standard width	
Dimension (D)	75 mm (2.95 in)	69.2 mm (2.72 in)
Slot position	without restrictions	
Weight	approx. 0.40 kg (0.88 lb)	

**RF characteristics**

Type	Parameter	DC to 6 GHz	6 GHz to 12.4 GHz	12.4 GHz to 18 GHz	18 GHz to 26.5 GHz	26.5 GHz to 40 GHz	40 GHz to 50 GHz
SPDT/DPDT, latching	VSWR <sup>18</sup>	≤ 1.30	≤ 1.40	≤ 1.50	≤ 1.70	≤ 1.90	≤ 1.90
	insertion loss	< 0.5 dB/ ≤ 0.30 dB <sup>18</sup>	< 0.7 dB/ ≤ 0.40 dB <sup>18</sup>	< 0.7 dB/ ≤ 0.50 dB <sup>18</sup>	< 1.0 dB/ ≤ 0.70 dB <sup>18</sup>	< 1.0 dB/ ≤ 0.80 dB <sup>18</sup>	< 1.1 dB/ ≤ 1.10 dB <sup>18</sup>
	isolation <sup>18</sup>	≥ 70 dB	≥ 60 dB	≥ 60 dB	≥ 55 dB	≥ 50 dB	≥ 50 dB
	average power <sup>18,21</sup>	80 W	60 W	50 W	20 W	10 W	5 W
SP6T, latching	VSWR <sup>18</sup>	≤ 1.30	≤ 1.40	≤ 1.50	≤ 1.70	≤ 1.90	≤ 2.20
	insertion loss	< 0.4 dB/ ≤ 0.20 dB <sup>18</sup>	< 0.6 dB/ ≤ 0.40 dB <sup>18</sup>	< 0.7 dB/ ≤ 0.50 dB <sup>18</sup>	< 0.9 dB/ ≤ 0.70 dB <sup>18</sup>	< 1.1 dB/ ≤ 0.90 dB <sup>18</sup>	< 1.4 dB/ ≤ 1.20 dB <sup>18</sup>
	isolation <sup>18</sup>	≥ 70 dB	≥ 60 dB	≥ 60 dB	≥ 55 dB	≥ 50 dB	≥ 50 dB
	average power <sup>18,21</sup>	40 W	30 W	25 W	15 W	5 W	3 W

**DC to 50 GHz, relays with 2.4 mm connectors, terminated****R&S®OSP-B121U/-B122U (SPDT, SP6T)**

Parameter	R&S®OSP-B121U	R&S®OSP-B122U
Number and type of relays	1, 2 or 3 × SPDT, terminated	1 × SP6T, terminated
Relay type	coaxial relay, 2.4 mm, K female	
Frequency range	DC to 50 GHz	
Relay impedance	50 Ω	
Termination impedance	50 Ω (extern)	50 Ω (intern)
Maximum termination power	1 W per termination	1 W per termination, 3 W per relay
Relay switching time (nom.) <sup>18</sup>	10 ms	15 ms
Trigger switching time	10 ms	15 ms
Number of switching cycles	2 million	2 million per position
Current consumption (module)	205 mA per relays, max. 615 mA	max. 120 mA (+27 V DC)
Dimensions (W × H × D)	107.6 mm × 65.5 mm × 88.0 mm (4.24 in × 2.58 in × 3.46 in)	107.6 mm × 65.5 mm × 79.4 mm (4.24 in × 2.58 in × 3.13 in)
Slot position	without restrictions	with restrictions, see table on page 24
Weight	approx. 0.35 kg (0.77 lb)	approx. 0.30 kg (0.66 lb)

**RF characteristics**

Type	Parameter	DC to 6 GHz	6 GHz to 12.4 GHz	12.4 GHz to 18 GHz	18 GHz to 26.5 GHz	26.5 GHz to 40 GHz	40 GHz to 50 GHz
SPDT, failsafe	VSWR <sup>18</sup>	≤ 1.40	≤ 1.40	≤ 1.50	≤ 1.70	≤ 1.90	≤ 1.90
	insertion loss	< 0.4 dB/ ≤ 0.3 dB <sup>18</sup>	< 0.5 dB/ ≤ 0.4 dB <sup>18</sup>	< 0.6 dB/ ≤ 0.5 dB <sup>18</sup>	< 0.8 dB/ ≤ 0.7 dB <sup>18</sup>	< 0.9 dB/ ≤ 0.8 dB <sup>18</sup>	< 1.2 dB/ ≤ 1.1 dB <sup>18</sup>
	isolation <sup>18</sup>	≥ 70 dB	≥ 60 dB	≥ 60 dB	≥ 55 dB	≥ 50 dB	≥ 50 dB
	average power <sup>18,21</sup>	80 W	60 W	50 W	20 W	10 W	5 W
SP6T, failsafe (normally open)	VSWR <sup>18</sup>	≤ 1.40	≤ 1.40	≤ 1.50	≤ 1.70	≤ 1.90	≤ 2.20
	insertion loss	< 0.4 dB/ ≤ 0.20 dB <sup>18</sup>	< 0.6 dB/ ≤ 0.40 dB <sup>18</sup>	< 0.7 dB/ ≤ 0.50 dB <sup>18</sup>	< 0.9 dB/ ≤ 0.70 dB <sup>18</sup>	< 1.1 dB/ ≤ 0.90 dB <sup>18</sup>	< 1.4 dB/ ≤ 1.20 dB <sup>18</sup>
	isolation <sup>18</sup>	≥ 70 dB	≥ 60 dB	≥ 60 dB	≥ 55 dB	≥ 50 dB	≥ 50 dB
	average power <sup>18,21</sup>	40 W	30 W	25 W	15 W	5 W	3 W

## DC to 67 GHz, relays with 1.85 mm connectors, non-terminated

## R&amp;S®OSP-B111V (SPDT, failsafe)/-B111VL (SPDT, latching)/-B112V (SP6T, failsafe)

Parameter	R&S®OSP-B111V	R&S®OSP-B111VL	R&S®OSP-B112V
Relay type	1 to 6 × SPDT, coaxial relay, failsafe	3 or 6 × SPDT, coaxial relay, latching	1 or 2 × SP6T, coaxial relay, failsafe
Connector type	1.85 mm female		
Relay impedance	50 Ω		
Frequency range	DC to 67 GHz		
Relay switching time (nom.) <sup>18</sup>	< 10 ms	< 15 ms	< 15 ms
Number of switching cycles <sup>18</sup>	2 million	0.6 million	2 million
Current consumption (module), (+27 V DC)	105 mA per relay, max. 630 mA per module	3 relays max. 300 mA <sup>19</sup> , 6 relays max. 600 mA <sup>19</sup>	max. 105 mA or 210 mA
Dimensions (W × H)	107.6 mm × 65.5 mm (4.24 in × 2.58 in), standard width	107.6 mm × 65.5 mm (4.24 in × 2.58 in), standard width	107.6 mm × 65.5 mm (4.24 in × 2.58 in), standard width
Dimension (D)	75 mm (2.95 in)	72 mm (2.83 in)	69.2 mm (2.72 in)
Slot position	without restrictions		
Weight	approx. 0.40 kg (0.88 lb)		

## RF characteristics

Type	Parameter	DC to 6 GHz	6 GHz to 12.4 GHz	12.4 GHz to 18 GHz	18 GHz to 26.5 GHz	26.5 GHz to 40 GHz	40 GHz to 50 GHz	50 GHz to 65 GHz	65 GHz to 67 GHz
SPDT, failsafe	VSWR <sup>18</sup>	≤ 1.30	≤ 1.40	≤ 1.50	≤ 1.70	≤ 1.90	≤ 1.90	≤ 1.90	
	insertion loss	< 0.4 dB/ ≤ 0.3 dB <sup>18</sup>	< 0.5 dB/ ≤ 0.4 dB <sup>18</sup>	< 0.6 dB/ ≤ 0.5 dB <sup>18</sup>	< 0.8 dB/ ≤ 0.7 dB <sup>18</sup>	< 0.9 dB/ ≤ 0.8 dB <sup>18</sup>	< 1.2 dB/ ≤ 1.1 dB <sup>18</sup>	< 1.2 dB/ ≤ 1.1 dB <sup>18</sup>	
	isolation <sup>18</sup>	≥ 70 dB	≥ 60 dB	≥ 60 dB	≥ 55 dB	≥ 50 dB	≥ 50 dB	≥ 50 dB	
	average power <sup>18,21</sup>	80 W	60 W	50 W	20 W	10 W	5 W	3 W	
SPDT, latching	VSWR <sup>18</sup>	≤ 1.20	≤ 1.25	≤ 1.30	≤ 1.70	≤ 1.90	≤ 1.90	≤ 1.90	
	insertion loss	< 0.6 dB/ ≤ 0.45 dB <sup>18</sup>	< 0.7 dB/ ≤ 0.56 dB <sup>18</sup>	< 0.8 dB/ ≤ 0.68 dB <sup>18</sup>	< 0.9 dB/ ≤ 0.8 dB <sup>18</sup>	< 1.0 dB/ ≤ 0.91 dB <sup>18</sup>	< 1.1 dB/ ≤ 0.99 dB <sup>18</sup>	< 1.2 dB/ ≤ 1.12 dB <sup>18</sup>	
	isolation <sup>18</sup>	≥ 90 dB	≥ 85 dB	≥ 75 dB	≥ 70 dB	≥ 70 dB	≥ 65 dB	≥ 60 dB	
	average power <sup>18,21</sup>	23 W	16 W	14 W	12 W	6 W	3 W	1 W	
SP6T, failsafe	VSWR <sup>18</sup>	≤ 1.30	≤ 1.40	≤ 1.50	≤ 1.70	≤ 1.90	≤ 2.20	≤ 2.20	≤ 2.20
	insertion loss	< 0.6 dB/ ≤ 0.3 dB <sup>18</sup>	< 0.7 dB/ ≤ 0.4 dB <sup>18</sup>	< 0.8 dB/ ≤ 0.5 dB <sup>18</sup>	< 0.9 dB/ ≤ 0.7 dB <sup>18</sup>	< 1.0 dB/ ≤ 0.9 dB <sup>18</sup>	< 1.3 dB/ ≤ 1.2 dB <sup>18</sup>	< 1.2 dB/ ≤ 1.2 dB <sup>18</sup>	< 1.7 dB/ ≤ 1.7 dB <sup>18</sup>
	isolation <sup>18</sup>	≥ 70 dB	≥ 60 dB	≥ 60 dB	≥ 55 dB	≥ 50 dB	≥ 50 dB	≥ 50 dB	≥ 50 dB
	average power <sup>18,21</sup>	40 W	30 W	25 W	15 W	5 W	3 W	1 W	1 W

## DC to 67 GHz, relays with 1.85 mm connectors, terminated

## R&amp;S®OSP-B121VL/-B122VL (SPDT, SP6T)

Parameter	R&S®OSP-B121VL	R&S®OSP-B122VL
Number and type of relays	1 to 6 × SPDT, terminated	1 × SP6T, latching, terminated
Relay type	coaxial relay, 1.85 mm	coaxial relay, 1.85 mm
Frequency range	DC to 67 GHz	DC to 67 GHz
Relay impedance	50 Ω	50 Ω
Termination impedance	50 Ω (internal)	50 Ω (internal)
Maximum termination power	1 W CW per termination, 7 V DC, 50 W (pk), 10 μs maximum pulse duration	1 W per termination, 3 W per relay
Relay switching time (nom.) <sup>18</sup>	10 ms	15 ms
Trigger switching time	10 ms	15 ms
Number of switching cycles	0.6 million	2 million per position
Current consumption (module)	150 mA per relays, max. 900 mA	max. 750 mA <sup>20</sup>
Dimensions (W × H)	107.6 mm × 65.5 mm (4.24 in × 2.58 in), standard width	107.6 mm × 65.5 mm (4.24 in × 2.58 in), standard width
Dimension (D)	72 mm (2.83 in)	69.2 mm (2.72 in)
Slot position	without restrictions	with restrictions, see table on page 24
Weight	approx. 0.30 kg (0.64 lb)	approx. 0.40 kg (0.88 lb)

## RF characteristics

Type	Parameter	DC to 4 GHz	4 GHz to 12.4 GHz	12.4 GHz to 20 GHz	20 GHz to 26.5 GHz	26.5 GHz to 40 GHz	40 GHz to 50 GHz	50 GHz to 65 GHz	65 GHz to 67 GHz
SPDT latching	VSWR <sup>18</sup>	≤ 1.15	≤ 1.25	≤ 1.30	≤ 1.70	≤ 1.90	≤ 1.90	≤ 1.90	≤ 1.90
	insertion loss	< 0.5 dB/ ≤ 0.41 dB <sup>18</sup>	< 0.7 dB/ ≤ 0.56 dB <sup>18</sup>	< 0.8 dB/ ≤ 0.68 dB <sup>18</sup>	< 0.9 dB/ ≤ 0.8 dB <sup>18</sup>	< 1.0 dB/ ≤ 0.91 dB <sup>18</sup>	< 1.1 dB/ ≤ 0.99 dB <sup>18</sup>	< 1.2 dB/ ≤ 1.12 dB <sup>18</sup>	< 1.2 dB/ ≤ 1.12 dB <sup>18</sup>
	isolation <sup>18</sup>	≥ 95 dB	≥ 85 dB	≥ 77 dB	≥ 70 dB	≥ 70 dB	≥ 70 dB	≥ 70 dB	≥ 70 dB
	power	not to exceed 2 W average, hot switching 2 W CW, 10 V DC, 100 W (pk), 10 μs maximum pulse duration							
SP6T, failsafe	VSWR <sup>18</sup>	≤ 1.30	≤ 1.40	≤ 1.50	≤ 1.70	≤ 1.90	≤ 2.20	≤ 2.20	≤ 2.20
	insertion loss	< 0.6 dB/ ≤ 0.3 dB <sup>18</sup>	< 0.7 dB/ ≤ 0.4 dB <sup>18</sup>	< 0.8 dB/ ≤ 0.5 dB <sup>18</sup>	< 0.9 dB/ ≤ 0.7 dB <sup>18</sup>	< 1.0 dB/ ≤ 0.9 dB <sup>18</sup>	< 1.3 dB/ ≤ 1.2 dB <sup>18</sup>	< 1.2 dB/ ≤ 1.4 dB <sup>18</sup>	< 1.7 dB/ ≤ 1.7 dB <sup>18</sup>
	isolation <sup>18</sup>	≥ 70 dB	≥ 60 dB	≥ 60 dB	≥ 55 dB	≥ 50 dB	≥ 50 dB	≥ 50 dB	≥ 50 dB
	average power <sup>18,21</sup>	40 W	30 W	25 W	15 W	5 W	3 W	1 W	1 W

## Universal solid-state RF switch modules (SSR)

9 kHz to 6 GHz: R&S®OSP-B107 (SSR, reflective <sup>22</sup>),

9 kHz to 10 GHz: R&S®OSP-B127 and R&S®OSP-B128 (SSR, absorptive <sup>23</sup>)

Parameter	R&S®OSP-B107	R&S®OSP-B127	R&S®OSP-B128
Relay type	6 × SPDT, solid-state relay (SSR), reflective (shorted to ground)	6 × SPDT, solid-state relay (SSR), absorptive (terminated)	1 to 3 × SP6T, solid-state relay (SSR), absorptive (terminated)
Connector type	SMA (female)		
Relay impedance	50 Ω		
Termination impedance, power	0 Ω (short), 24 dBm	50 Ω, 24 dBm	50 Ω, 24 dBm
Frequency range	9 kHz to 6 GHz	9 kHz to 10 GHz	9 kHz to 10 GHz
Relay switching time (nom.) <sup>18, 24</sup>	7 μs	7 μs	7 μs
Settling time <sup>25</sup>	15 μs	15 μs	25 μs
Trigger switching time <sup>26</sup>	8 μs/10 μs	8 μs/10 μs	–
Number of switching cycles <sup>18</sup>	> 100 million		
Current consumption (module)	max. 100 mA (+27 V DC)	max. 100 mA (+27 V DC)	max. 100 mA (+27 V DC)
Dimensions (W × H)	107.6 mm × 65.5 mm (4.24 in × 2.58 in), standard width		
Dimension (D)	61.5 mm (2.42 in)	54.2 mm (2.13 in)	59.0 mm (2.34 in)
Slot position	without restrictions		
Weight	approx. 0.30 kg (0.66 lb)	approx. 0.30 kg (0.66 lb)	approx. 0.30 kg (0.66 lb)

### RF characteristics

Type	Parameter	9 kHz to 3 MHz	3 MHz to 10 MHz	10 MHz to 1 GHz	1 GHz to 2.5 GHz	2.5 GHz to 5 GHz	5 GHz to 6 GHz
R&S®OSP-B107, SSR	VSWR	< 1.30	< 1.30	< 1.30	< 1.38	< 1.30	< 1.45
	insertion loss	< 1.0 dB	< 1.0 dB	< 1.0 dB	< 1.0 dB	< 1.3 dB	< 1.3 dB
	isolation	> 38 dB	> 38 dB	> 38 dB	> 28 dB	> 20 dB	> 18 dB
	max. power <sup>27</sup>	12 dBm	30 dBm				
	max. voltage	+2.5 V					

Type	Parameter	9 kHz to 10 MHz	10 MHz to 2.5 GHz	2.5 GHz to 5 GHz	5 GHz to 10 GHz
R&S®OSP-B127, SSR	VSWR	≤ 1.43	≤ 1.43	≤ 1.9	≤ 1.9
	insertion loss	< 1.4 dB	< 1.4 dB	< 1.7 dB	< 2.5 dB
	isolation	≥ 42 dB	≥ 36 dB	≥ 30 dB	≥ 20 dB
	max. power <sup>27</sup>	≤ 1 MHz: 4 dBm, > 1 MHz: 30 dBm	30 dBm		
	max. voltage	–0.3 V to +3.0 V			

Type	Parameter	9 kHz to 1 GHz	1 GHz to 2 GHz	2 GHz to 5 GHz	5 GHz to 9 GHz	9 GHz to 10 GHz
R&S®OSP-B128, SSR	VSWR	≤ 2.2	≤ 1.9	≤ 2.0	≤ 1.9	≤ 2.6
	insertion loss	< 4.0 dB	< 4.0 dB	< 5.0 dB	< 6.0 dB	< 6.0 dB
	isolation	≥ 70 dB	≥ 70 dB	≥ 60 dB	≥ 45 dB	≥ 35 dB
	crosstalk	≥ 70 dB	≥ 70 dB	≥ 60 dB	≥ 45 dB	≥ 35 dB
	max. power <sup>27</sup>	≤ 1 MHz: 4 dBm, > 1 MHz: 30 dBm	30 dBm			
	max. voltage	–0.3 V to +3.0 V				

<sup>22</sup> No 50 Ω termination (open or short to ground).

<sup>23</sup> 50 Ω termination.

<sup>24</sup> 50 % CRTL on module bus to 90 % of the final value.

<sup>25</sup> 50 % CRTL on module bus to 0.1 dB of final value.

<sup>26</sup> Trigger switching time of module in R&S®OSP base unit/R&S®OSP-B200S2 satellite box.

<sup>27</sup> For feedthrough (cold and hot switching).

**9 kHz to 8 GHz: R&S®OSP-B142 (power SSR 40 dBm, reflective or with external termination 30 dBm)**

Parameter	R&S®OSP-B142 (model .03)	R&S®OSP-B142 (models .11/.12/.13)
Relay type	3 × DP3T, reflective, solid-state relay (SSR)	1 to 3 × SPDT, absorptive SSR (reflective DP3T with external termination)
Connector type	SMA female	
Relay impedance	50 Ω	
Termination impedance, power	–	2 pieces 50 Ω, 30 dBm
Frequency range	9 kHz to 6 (8) GHz <sup>28</sup>	
Relay switching time (nom.) <sup>29</sup>	≤ 7 μs	
Trigger switching time <sup>26</sup>	< 8 μs/10 μs	
Rise time/fall time <sup>30</sup>	≤ 1 μs	
Settling time (nom.) <sup>18, 31</sup>	≤ 20 ms	
Number of switching cycles <sup>18</sup>	> 100 million	
Current consumption (module)	max. 50 mA (+27 V DC)	
Dimensions (W × H)	107.6 mm × 65.5 mm (4.24 in × 2.58 in), standard width	
Dimension (D)	65 mm (2.56 in)	
Slot position	without restrictions	
Weight	approx. 0.30 kg (0.66 lb)	

**RF characteristics**

Type	Parameter	9 kHz to 2.5 GHz	2.5 GHz to 5 GHz	5 GHz to 6 GHz	6 GHz to 7 GHz <sup>28</sup>	7 GHz to 8 GHz <sup>28</sup>
R&S®OSP-B142 SSR	VSWR	≤ 1.33	≤ 1.67	≤ 1.9	≤ 2.32	≤ 3.00
	insertion loss	< 1.5 dB	< 2.0 dB	< 2.8 dB	< 2.8 dB	< 3.5 dB
	isolation	≥ 45 dB	≥ 40 dB	≥ 30 dB	≥ 30 dB	≥ 25 dB
	max. power <sup>27</sup>	40 dBm				
	max. power terminations	30 dBm				
	max. voltage	–0.3 V to +3.0 V				

<sup>28</sup> Operational up to 6 GHz, functional up to 8 GHz.

<sup>29</sup> 50 % CRTL on module bus to 90 % of the final value.

<sup>30</sup> 10 % to 90 % of final value.

<sup>31</sup> 50 % CRTL on module bus to 0.1 dB of the final value. The SSR of the R&S®OSP-B142 shows a creeping effect due to GaN technology. Settling time to 0.01 dB of final value is in the range of seconds.



**9 kHz to 43.5 GHz: R&S®OSP-B162K (absorptive SPDT)****9 kHz to 43.5 GHz: R&S®OSP-B164K (absorptive SP4T)**

Parameter	R&S®OSP-B162K (models .42/.44/.46)	R&S®OSP-B164K (models .42/.43/.44)
Relay type	2, 4 or 6 × SPDT, absorptive, solid-state relay (SSR)	2, 3 or 4 × SP4T, absorptive, solid-state relay (SSR)
Connector type	2.92 mm; K female	
Relay impedance	50 Ω	
Termination impedance, power	50 Ω, 23 dBm	50 Ω, 23 dBm
Frequency range	9 kHz to 43.5 GHz	
Trigger switching time <sup>26</sup>	< 8 μs	
Rise time/fall time <sup>32</sup>	≤ 1.5 μs	
Settling time (nom.) <sup>18, 33</sup>	≤ 10 μs	
Number of switching cycles <sup>18</sup>	> 100 million	
Current consumption (module)	max. 50 mA (+27 V DC)	
Dimensions (W × H)	107.6 mm × 65.5 mm (4.24 in × 2.58 in), standard width	
Dimension (D)	59 mm (2.33 in)	65.5 mm (2.58 in)
Slot position	without restrictions	
Weight	approx. 0.40 kg (0.88 lb)	

**RF characteristics**

Type	Parameter	9 kHz to 8 GHz	8 GHz to 12.4 GHz	12.4 GHz to 18 GHz	18 GHz to 26.5 GHz	26.5 GHz to 40 GHz	40 GHz to 43.5 GHz
R&S®OSP-B162K SSR	VSWR (through)	≤ 1.6	≤ 1.7	≤ 1.7	≤ 2.2	≤ 2.4	≤ 3.0
	VSWR (terminated)	≤ 1.4	≤ 1.5	≤ 1.5	≤ 1.5	≤ 2.6	≤ 3.0
	insertion loss	< 2.0 dB	< 2.2 dB	< 2.5 dB	< 3.5 dB	< 5.0 dB	< 6.5 dB
	isolation	≥ 55 dB	≥ 50 dB	≥ 40 dB	≥ 45 dB	≥ 35 dB	≥ 40 dB
	max. power	23 dBm <sup>34</sup>	23 dBm	23 dBm	23 dBm	23 dBm	20 dBm
	max. DC voltage	0 V for specs above; -2.5 V to +2.5 V without damage to the switch					

Type	Parameter	9 kHz to 8 GHz	8 GHz to 12.4 GHz	12.4 GHz to 18 GHz	18 GHz to 26.5 GHz	26.5 GHz to 43.5 GHz
R&S®OSP-B164K SSR	VSWR (through)	≤ 1.6	≤ 1.7	≤ 1.7	≤ 1.7	≤ 2.7
	VSWR (terminated)	≤ 1.6	≤ 1.6	≤ 1.6	≤ 1.6	≤ 2.2
	insertion loss	< 2.5 dB	< 3.0 dB	< 3.5 dB	< 4.0 dB	< 6.5 dB
	isolation	≥ 45 dB	≥ 40 dB	≥ 35 dB	≥ 35 dB	≥ 35 dB
	max. power	23 dBm <sup>35</sup>	23 dBm	23 dBm	23 dBm	20 dBm
	max. DC voltage	0 V for specs above; -2.5 V to +2.5 V without damage to the switch				

<sup>32</sup> 10 % to 90 % of final value.<sup>33</sup> 50 % CRTL on module bus to 0.1 dB of the final value. The SSR of the R&S®OSP-B142 shows a creeping effect due to GaN technology.

Settling time to 0.01 dB of final value is in the range of seconds.

<sup>34</sup> Maximum power from 9 kHz to 200 kHz: +13 dBm.<sup>35</sup> Maximum power from 9 kHz to 100 kHz: +7 dBm, from 100 kHz to 1 MHz: +15 dBm.

## Switching and settling time of RF relays

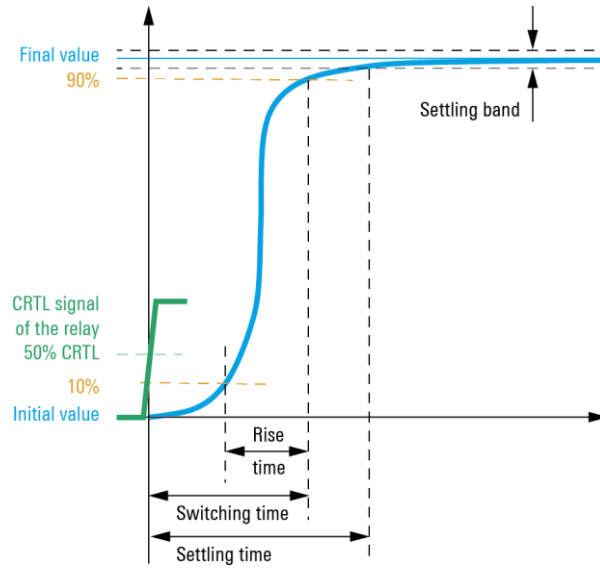

*Switching and settling time of electromechanical coaxial relays and SSR*

## Auxiliary modules

### 9 kHz to 40 GHz: R&S®OSP-B171H digital RF attenuator

Parameter	R&S®OSP-B171H (models .22/.44)
Relay type	2 or 4 digital RF attenuators
Connector type	2.92 mm; K female
Relay impedance	50 Ω
Frequency range	9 kHz to 40 GHz
Minimum step width	2 dB
Number of attenuation steps	16 (0 to 15)
Trigger switching time <sup>26</sup>	< 100 μs
Settling time (nom.) <sup>18, 36</sup>	< 10 μs
Current consumption (module)	max. 50 mA (+27 V DC)
Dimensions (W x H)	107.6 mm x 65.5 mm (4.24 in x 2.58 in), standard width
Dimension (D)	66.5 mm (2.62 in)
Slot position	without restrictions
Weight	approx. 0.30 kg (0.66 lb)

#### RF characteristics

Type	Parameter	9 kHz to 6 GHz	6 GHz to 12.4 GHz	12.4 GHz to 18 GHz	18 GHz to 30 GHz	30 GHz to 40 GHz
R&S®OSP-B171H	VSWR	≤ 1.5	≤ 1.4	≤ 1.6	≤ 1.8	≤ 3.0
	insertion loss	< 3.0 dB	< 3.0 dB	< 3.0 dB	< 6.0 dB	< 7.0 dB
	attenuation step error <sup>37</sup>	±(0.3 + 3 % of attenuation step value) dB	±(0.3 + 3 % of attenuation step value) dB	±(0.3 + 3 % of attenuation step value) dB	±(0.3 + 6 % of attenuation step value) dB	±(1.0 + 14 % of attenuation step value) dB
	max. power input port	+25 dBm <sup>38</sup>	+25 dBm	+25 dBm	+25 dBm	+22 dBm
	max. power output port	+15 dBm <sup>39</sup>	+15 dBm	+15 dBm	+15 dBm	+12 dBm
	max. DC voltage	0 V for specs above; -2.5 V to +2.5 V without damage to the attenuator				

<sup>36</sup> 50 % CRTL on module bus to 0.1 dB of the final value. The SSR of the R&S®OSP-B142 shows a creeping effect due to GaN technology. Settling time to 0.01 dB of final value is in the range of seconds.

<sup>37</sup> Possible attenuation step values are: 0, 2, 4, 6, 8, 10, 12, 14, 16, 18, 20, 22, 24, 26, 28, 30.

<sup>38</sup> Maximum power from 9 kHz to 500 kHz: +10 dBm.

<sup>39</sup> Maximum power from 9 kHz to 500 kHz: 0 dBm.

## Digital I/O and multiplexer modules

### R&S®OSP-B103 (16 x digital I/O module)

Digital input channels	0 V to 3.3 V DC (LV-CMOS), max. 5.5 V	16, D-Sub-25 male connector
Digital output channels	open drain, max. +27 V DC, max. 200 mA	16, D-Sub-25 female connector
Switching time	outputs, depends on external wiring	approx. 200 ns
Trigger switching time <sup>26</sup>		< 1.2 µs/3 µs
Output current	e.g. for open drain	max. 800 mA (+27 V DC)
Current consumption	module	max. 800 mA (+27 V DC)
Dimensions (W x H x D)	standard width	107.6 mm x 65.5 mm x 63.4 mm (4.24 in x 2.58 in x 2.50 in)
Slot position		without restrictions
Weight		approx. 0.10 kg (0.22 lb)

### R&S®OSP-B108 (multiplexer module, 6-channel, 4-wire)

Number of inputs		1 x 4-wire, 1 x ground, unswitched
Number of outputs		6 x 4-wire, 3 x ground, unswitched (1 x per connector)
Relay type		electromechanical
Maximum switchable power		60 W (UL 2 A/30 V)
Maximum current	continuous load/short-time < 10 ms	2 A/4 A
Maximum switchable current		2 A
Maximum switchable voltage		30 V DC, 60 V AC
Spreading resistance	switched path	0.1 Ω
Relay switching time (nom.)		< 3 ms
Trigger switching time		< 3 ms
Number of switching cycles <sup>18</sup>	without load	10 million
	30 V DC/1 A, to max. 30 W	1 million
	30 V DC/2 A, to max. 60 W	0.1 million
Connectors (external)	input	1 x D-Sub-9 male connector
	outputs	3 x D-Sub-9 female connector
Current consumption	module	< 40 mA (+27 V DC)
Dimensions (W x H x D)	standard width	107.6 mm x 69.5 mm x 70 mm (4.24 in x 2.74 in x 2.76 in)
Slot position		without restrictions
Weight		0.16 kg (0.352 lb)

## Components for system applications

### R&S®OSP-B104 (EMS module with drivers for external power relays)

Interfaces for external relays	RF high-load relay <sup>40</sup>	4
Control signal	impulse, presetting adjustable	100 ms 0 s to 950 ms, in steps of 50 ms
Control lines	pick-up current, max. 1.5 A at 24 V	2 per relay
Number of switching cycles <sup>18</sup>		max. 100 000
Return signal line (optocoupler input)	24 V DC, typ. 7.5 mA	1 per relay
Power supply of relay	24 V DC, ± 2 V	max. 2.5 A short-time, 0.1 A continuous
Interlock loop (optocoupler input)	24 V DC, typ. 15 mA	1
Number of digital input channels	0 V to 3.3 V DC, max. 5.5 V (LV-CMOS)	4
Number of digital output channels	open drain, max. +27 V DC, max. 200 mA	5
Connectors	interfaces for external relays	4 × D-Sub-9 female connector
	digital I/O, interlock	1 × D-Sub-15 female connector
Current consumption	module,	max. 800 mA (+27 V DC)
	internal separate current feed	max. 15 A (+5 V DC)
Dimensions (W × H × D)	standard width	107.6 mm × 65.5 mm × 264.1 mm (4.24 in × 2.58 in × 10.40 in)
Slot position	with restrictions, see table rules for integration on page 24	
Weight	approx. 0.40 kg (0.88 lb)	

### R&S®OSP-B114 (EMS module with N relay for compact test systems)

Number of RF relays	DPDT (N female)	1
	SPDT (SSR) terminated (SMA female) <sup>41</sup> (interlock controlled)	1
Connectors	digital output interface	1 × D-Sub-9 female connector
	digital input and interlock interface	1 × D-Sub-9 male connector
Interlock loop (optocoupler input)	24 V DC, typ. 15 mA	1
Interlock output (relay contact)	max. 30 V DC, max. 1 A	2
Interlock output (LED driver)	typ. 1.8 V DC, max. 1.4 mA	1
Number of digital input channels	0 V to 3.3 V DC, max. 5.5 V (LV-CMOS)	4
Number of digital output channels	open drain, max. +27 V DC, max. 200 mA per output, max. 600 mA in total	4
Current consumption	module	max. 200 mA (+27 V DC), excluding digital outputs
Dimensions (W × H × D)	standard width	107.6 mm × 65.5 mm × 88 mm (4.24 in × 2.58 in × 3.46 in)
Slot position	without restrictions	
Weight	approx. 0.30 kg (0.66 lb)	

#### RF characteristics

Type	Parameter	DC to 1 GHz	1 GHz to 2 GHz	2 GHz to 3 GHz	3 GHz to 8 GHz	8 GHz to 12.4 GHz
DPDT, failsafe	VSWR <sup>18</sup>	≤ 1.15	≤ 1.20	≤ 1.25	≤ 1.35	≤ 1.50
	insertion loss	≤ 0.15 dB <sup>18</sup>	< 0.4 dB/ ≤ 0.20 dB <sup>18</sup>	< 0.4 dB/ ≤ 0.25 dB <sup>18</sup>	< 0.4 dB/ ≤ 0.35 dB <sup>18</sup>	< 0.5 dB/ ≤ 0.50 dB <sup>18</sup>
	isolation <sup>18</sup>	≥ 85 dB	≥ 80 dB	≥ 75 dB	≥ 70 dB	≥ 60 dB
	average power <sup>18, 21</sup>	700 W	500 W	400 W	250 W	200 W
	impedance	50 Ω				
	number of switching cycles <sup>18</sup>	1 million				

<sup>40</sup> Relay types, e.g. DPDT relay, Spinner 512670 (1 kW/5 GHz) or DPDT relay, Spinner 640075 (10 kW/1 GHz).

<sup>41</sup> For data on SPDT (SSR) relay, see R&S®OSP-B127.

**R&S®OSP-PM-I (passive module for integration of one power sensor)**

Parameter	R&S®OSP-PM-I	
Interfaces	for Rohde & Schwarz USB power sensors with N connector, e.g. for R&S®NRPxxS, R&S®NRPxxT, R&S®NRPxxA, R&S®NRPxxP with R&S®NRP-ZK6 or R&S®NRP-Z211/-Z221	USB feedthrough filter (external USB-B female connector to internal ODU female connector, series L) RF feedthrough (N female connector to N female connector)
Current consumption	no module bus required	–
Dimensions (W x H x D)	standard width	107.6 mm x 65.5 mm x 200 mm (8.51 in x 2.58 in x 7.87 in)
Slot position		with restrictions, see table rules for integration on page 24
Weight		approx. 0.25 kg (0.55 lb)

**R&S®OSP-BCST module kit for R&S®OSP320**

The R&S®OSP-BCST module kit for R&S®OSP320 offers the flexibility and freedom to realize customized RF switch module designs. The module kit comes with:

- Front plate that enables a better organized RF interface
- Base plate for mounting R&S®OSP modules and third-party components
- +5 V DC and +27 V DC terminal block for feeding active third-party components
- Additional space on 35 mm DIN rail for optional DC/DC converters (e.g. Meanwell DDR-15G-12)

The R&S®OSP-BCST is not pre-installed, i.e. not mounted into the R&S®OSP320 base unit.



R&S®OSP module mounting positions	3 x 3 configuration (vertical module orientation)	up to 9 modules
	2 x 4 configuration (horizontal module orientation)	up to 8 modules
Module width		only standard width modules (single slot)
Module depth		max. 70 mm
Power terminal block		+27 V DC, max. 2 A (fused) +5 V DC, max. 2 A (fused)
Dimensions		
Base plate	W x H x D	372.5 mm x 287.0 mm x 5 mm (14.7 in x 11.3 in x 0.2 in)
Front panel	W x H	331.5 mm x 107.6 mm (13.1 in x 4.2 in)
Supporting bolts	length	72 mm (2.8 in)
Weight	without modules	approx. 2.3 kg (5.1 lb)

**R&S®OSP-BL01 load unit, 2 RU**

The R&S®OSP-BL01 is a 19" rack module to mount high power loads inside a 19" rack. This module is intended for use with an R&S®OSP220 and 3 x R&S®OSP-B182E.



The RF loads are not part of delivery of the R&S®OSP-BL01.



Connections for high power loads	> 10 W	16
RF cables	external cables to R&S®OSP-B182E	16, length: 230 mm (9.1 in)
	internal cables to loads	8, length: 220 mm (8.7 in)
	internal cables to loads	8, length: 400 mm (15.8 in)
Dimensions (W x H x D)	without handles	423 mm x 88 mm x 440 mm (16.7 in x 3.5 in x 17.3 in)
	with handles	467 mm x 88 mm x 440 mm (18.4 in x 3.5 in x 17.3 in)
Weight		approx. 2.0 kg (4.4 lb) without cables and RF loads
Maximum payload		20 kg (44 lb)

## Options for RF feedthroughs

### R&S®OSP-B011 and R&S®OSP-B012 module panels for RF feedthroughs

R&S®OSP-B011	module panel, 12 x SMA mounting holes for R&S®OSP-Z011 or R&S®OSP-Z012, standard width	
R&S®OSP-B012	module panel, 4 x N mounting holes for R&S®OSP-Z010 or R&S®OSP-Z011, standard width	

### R&S®OSP-Z010/-Z011/-Z012 (cable sets for the module panels)

R&S®OSP-Z010	4 x RF cables, N female to N female
R&S®OSP-Z011	4 x RF cables, N female to SMA female
R&S®OSP-Z012	4 x RF cables, SMA female to SMA female

Type	Parameter	DC to 1 GHz	1 GHz to 3 GHz	3 GHz to 6 GHz	6 GHz to 12.4 GHz	12.4 GHz to 18 GHz
R&S®OSP-Z010	VSWR	≤ 1.07	≤ 1.1	≤ 1.1	≤ 1.2	≤ 1.4
	insertion loss	< 0.35 dB	< 0.6 dB	< 0.8 dB	< 1.2 dB	< 1.4 dB
	average power	700 W	400 W	250 W	200 W	150 W
R&S®OSP-Z011	VSWR	≤ 1.07	≤ 1.1	≤ 1.1	≤ 1.2	≤ 1.4
	insertion loss	< 0.35 dB	< 0.6 dB	< 0.8 dB	< 1.2 dB	< 1.4 dB
	average power	240 W	240 W	150 W	120 W	100 W
R&S®OSP-Z012	VSWR	≤ 1.05	≤ 1.07	≤ 1.1	≤ 1.15	≤ 1.2
	insertion loss	< 0.35 dB	< 0.6 dB	< 0.8 dB	< 1.2 dB	< 1.4 dB
	average power	240 W	240 W	150 W	120 W	100 W

## Accessories for the R&S®OSP-B200S2 satellite box

### R&S®OSP-B200R remote control module

Input	internal	2 × R&S®OSP module buses
Satellite delay time ( $t_{SD}$ )	(R&S®OSP-B200R and R&S®OSP-B200S2)	< 1.8 $\mu$ s
Interface to satellite box	serial electrical bus (wired link)	1 × D-Sub-9 female connector
	fiber-optic cable (FOL), optional	1 × SC female connector, simplex
Current consumption via module buses	via serial electrical bus	max. 1600 mA (+27 V DC)
	via FOL	0 mA (+27 V DC)
Status indication	power, link/busy	2 × LEDs
Dimensions (W × H × D)	simple module width	107.6 mm × 65.5 mm × 68 mm (4.2 in × 2.6 in × 2.7 in)
Slot position		1, 2 and/or 3, F1, F2
Weight		approx. 0.09 kg (0.2 lb)

### R&S®OSP-B200P AC power supply

Rated voltage, rated frequency		90 V to 264 V AC, 47 Hz to 63 Hz
Input current		1.4 A (RMS), 115 V AC
		0.7 A (RMS), 230 V AC
Output power		max. 105 W
Output voltage, output current		28 V to 29 V, 3.75 A
Temperature	operating temperature range	0 °C to +60 °C
	storage temperature range	-40 °C to +85 °C
Dimensions (W × H × D)	without cable	75.2 mm × 39.0 mm × 146.2 mm (3.0 in × 1.5 in × 5.8 in)
Weight	without power cable	approx. 0.60 kg (1.32 lb)

### Connection cables between R&S®OSP-B200R and R&S®OSP-B200S

Cables for direct connection from an R&S®OSP base unit via an optional R&S®OSP-B200R remote control module with an R&S®OSP-B200S2 satellite box		
R&S®OSP-Z200A	serial electrical bus cable	D-Sub-9 connector at both ends, length: 5 m
R&S®OSP-Z200B		D-Sub-9 connector at both ends, length: 10 m
R&S®OSP-Z201A	fiber-optic link (FOL) cable, simplex	SC connector at both ends, length: 5 m
R&S®OSP-Z201B		SC connector at both ends, length: 10 m
R&S®OSP-Z201C		SC connector at both ends, length: 20 m
R&S®OSP-Z201D		SC connector at both ends, length: 30 m
R&S®OSP-Z201E		SC connector at both ends, length: 40 m
Cables from R&S®OSP-B200R or R&S®OSP-B200S2 to FSMA feedthroughs (FSMA to FSMA coupler)		
R&S®OSP-Z203XF	fiber-optic link (FOL) cable and 1 × FSMA to FSMA coupler (two cables are required)	SC to FSMA connector, length: 0.5 m
R&S®OSP-Z203YF		SC to FSMA connector, length: 1 m
R&S®OSP-Z203ZF		SC to FSMA connector, length: 3 m
R&S®OSP-Z203AF		SC to FSMA connector, length: 5 m
R&S®OSP-Z203BF		SC to FSMA connector, length: 10 m
R&S®OSP-Z203CF		SC to FSMA connector, length: 20 m
R&S®OSP-Z203DF		SC to FSMA connector, length: 30 m
R&S®OSP-Z203EF		SC to FSMA connector, length: 40 m
Extension cables between two FSMA feedthroughs (FSMA to FSMA couplers)		
R&S®OSP-Z204XF	fiber-optic link (FOL) cable and 1 × FSMA to FSMA coupler (two OSP-Z203xF cables are required)	FSMA to FSMA connector, length: 0.5 m
R&S®OSP-Z204YF		FSMA to FSMA connector, length: 1 m
R&S®OSP-Z204ZF		FSMA to FSMA connector, length: 3 m
R&S®OSP-Z204AF		FSMA to FSMA connector, length: 5 m
R&S®OSP-Z204BF		FSMA to FSMA connector, length: 10 m
R&S®OSP-Z204CF		FSMA to FSMA connector, length: 20 m
R&S®OSP-Z204DF		FSMA to FSMA connector, length: 30 m
R&S®OSP-Z204EF		FSMA to FSMA connector, length: 40 m



## Ordering information

### R&S®OSP base units and satellite box

Designation	Type	Order No.
<b>R&amp;S®OSP base units</b>		
R&S®OSP base unit (2 RU), with 3 + 3 module slots and monitor interface	R&S®OSP220	1528.3105K02
R&S®OSP base unit (2 RU), with 3 + 2 module slots and touchscreen	R&S®OSP230	1528.3105K03
R&S®OSP base unit (3 RU), with 5 + 5 module slots and monitor interface	R&S®OSP320	1528.3111K02
Accessories: power cord, Ethernet cable (length: 2 m), operating manual (quick start guide)		
<b>Satellite boxes</b>		
Satellite box, with electrical interface (wired link)	R&S®OSP-B200S2	1528.3134K02
Satellite box, with fiber-optic link (FOL) interface and electrical interface (wired link)		1528.3134K04

### Options for R&S®OSP base units

Designation	Type	Order No.
Hardware trigger function (license key), for all R&S®OSP base units	R&S®OSP-K100	1528.3486.02
Touchscreen module, for R&S®OSP320 only	R&S®OSP-B300M	1528.3128.02

### Switch and control modules for R&S®OSP <sup>42</sup>

Designation	Type	Order No.
<b>RF switch modules with electromechanical RF coaxial relays</b>		
<b>DC to 12.4 GHz</b>		
3 × SPDT (N), 3 × SPDT (BNC), DC to 900 MHz, non-terminated	R&S®OSP-B106	1505.5601.02
2 × SPDT (N), non-terminated	R&S®OSP-B131	1505.4740.02
6 × SPDT (N), non-terminated	R&S®OSP-B132	1505.4757.02
1 × SP6T (N), non-terminated	R&S®OSP-B133	1528.3157.02
2 × DPDT (N), non-terminated	R&S®OSP-B136	1522.4500.02
<b>DC to 18 GHz</b>		
6 × SPDT (SMA), non-terminated	R&S®OSP-B101	1505.5101.02
6 × SPDT (SMA), non-terminated, latching	R&S®OSP-B101L	1505.5101.52
2 × SP6T (SMA), non-terminated	R&S®OSP-B102	1505.5201.02
2 × SP6T (SMA), non-terminated, latching	R&S®OSP-B102L	1505.5201.52
1 × SP6T, n × SPDT (SMA), non-terminated, n = 1 to 3	R&S®OSP-BM6n	1528.1625.1n
2 × DPDT (SMA), non-terminated	R&S®OSP-B116	1515.5827.02
1 × SP8T (SMA), 2 × SPDT (SMA), non-terminated	R&S®OSP-B119	1515.5856.02
3 × SPDT (SMA), terminated	R&S®OSP-B121	1515.5504.02
1 × SP6T (SMA), terminated	R&S®OSP-B122	1515.5510.03
6 × SPDT (SMA), 1 × SP6T (SMA), terminated	R&S®OSP-B123	1515.5527.03
3 × SPDT (SMA), 2 × SP6T (SMA), terminated	R&S®OSP-B124	1515.5533.03
6 × SPDT (SMA), 3 × SP6T (SMA), terminated	R&S®OSP-B125	1515.5540.03
1 × SP8T (SMA), terminated, 2 × SPDT (SMA) non-terminated	R&S®OSP-B129	1517.7004.02
<b>DC to 26.5 GHz</b>		
6 × SPDT (SMA, up to 26.5 GHz), non-terminated	R&S®OSP-B111E	1505.4605.26
n × SP6T (SMA, up to 26.5 GHz), non-terminated, n = 1 or 2	R&S®OSP-B112E	1528.1560.1n
1 × SP6T, n × SPDT (SMA, up to 26.5 GHz), non-terminated, n = 1 to 3	R&S®OSP-BM6nE	1528.1625.2n
2 × DPDT (SMA, up to 26.5 GHz), non-terminated	R&S®OSP-B116E	1515.5827.26
1 × SP8T (SMA, up to 26.5 GHz), 2 × SPDT (SMA), non-terminated	R&S®OSP-B119E	1515.5856.26
3 × SPDT (SMA, up to 26.5 GHz), terminated	R&S®OSP-B121E	1515.5504.26
1 × SP6T (SMA, up to 26.5 GHz), terminated	R&S®OSP-B122E	1528.1525.26
6 × SPDT (SMA, up to 26.5 GHz), 3 × SP6T (SMA), terminated	R&S®OSP-B125E	1515.5540.26
1 × SP8T (SMA, up to 26.5 GHz), terminated, 2 × SPDT (SMA), non-terminated	R&S®OSP-B129E	1517.7004.26
1 × SP6T (SMA, up to 26.5 GHz), 6 connectors for external termination	R&S®OSP-B182E	1528.3263.21

<sup>42</sup> All electromechanical relays not designated as latching (bistable) are failsafe (monostable).

Designation	Type	Order No.
<b>DC to 40 GHz</b>		
n × SPDT (2.92 mm), non-terminated, n = 3 or 6	R&S®OSP-B111H	1505.4605.4n
n × SP6T (2.92 mm), non-terminated, n = 1 or 2	R&S®OSP-B112H	1528.1560.4n
1 × SP6T, n × SPDT (2.92 mm), non-terminated, n = 1 to 3	R&S®OSP-BM6nH	1528.1625.4n
2 × DPDT (2.92 mm), non-terminated	R&S®OSP-B116H	1515.5827.40
3 × SPDT (2.92 mm), terminated	R&S®OSP-B121H	1515.5504.40
1 × SP6T (2.92 mm), terminated	R&S®OSP-B122H	1528.1525.02
6 × SPDT (2.92 mm), 3 × SP6T (2.92 mm), terminated	R&S®OSP-B125H	1515.5540.40
<b>DC to 50 GHz</b>		
n × SPDT (2.4 mm), non-terminated, n = 3 or 6	R&S®OSP-B111U	1505.4605.5n
n × SPDT (2.4 mm), non-terminated, latching, n = 3 or 6	R&S®OSP-B111UL	1528.1531.1n
n × SP6T (2.4 mm), non-terminated, n = 1 or 2	R&S®OSP-B112U	1528.1560.5n
1 × SP6T (2.4 mm), non-terminated, latching	R&S®OSP-B112UL	1528.1548.11
1 × SP6T, n × SPDT (2.4 mm), non-terminated, n = 1 to 3	R&S®OSP-BM6nU	1528.1625.5n
n × DPDT (2.4 mm), non-terminated, n = 1 or 2	R&S®OSP-B116U	1515.5827.5n
n × SPDT (2.4 mm), terminated, n = 1 to 3	R&S®OSP-B121U	1515.5504.5n
1 × SP6T (2.4 mm), terminated	R&S®OSP-B122U	1528.1525.51
<b>DC to 67 GHz</b>		
n × SPDT (1.85 mm), non-terminated, n = 1 to 6	R&S®OSP-B111V	1505.4605.6n
n × SPDT (1.85 mm), non-terminated, latching, n = 3 or 6	R&S®OSP-B111VL	1515.5991.1n
n × SP6T (1.85 mm), non-terminated, n = 1 or 2	R&S®OSP-B112V	1528.1560.6n
n × SPDT (1.85 mm), terminated, latching, n = 1 to 3	R&S®OSP-B121VL	1528.1654.6n
1 × SP6T (1.85 mm), terminated, latching	R&S®OSP-B122VL	1528.1760.61
<b>RF switch modules with RF coaxial solid-state relays (SSR)</b>		
6 × SPDT (SMA), SSR, 9 kHz to 6 GHz, reflective	R&S®OSP-B107	1505.5901.02
6 × SPDT (SMA), SSR, 9 kHz to 10 GHz, absorptive <sup>23</sup>	R&S®OSP-B127	1505.4728.02
n × SP6T (SMA), SSR, 9 kHz to 10 GHz, absorptive <sup>23</sup> , n = 1 to 3	R&S®OSP-B128	1505.4734.1n
3 × DP3T (SMA), 40 dBm power SSR, 9 kHz to 8 GHz, reflective	R&S®OSP-B142	1505.4792.03
n × SPDT (SMA), 40 dBm power SSR, 9 kHz to 8 GHz, absorptive <sup>23</sup> , n = 1 to 3 (external termination: 30 dBm) <sup>43</sup>		1505.4792.1n
n × SPDT (2.92 mm), SSR, 9 kHz to 43.5 GHz, absorptive, n = 2, 4 or 6	R&S®OSP-B162K	1528.1677.4n
n × SP4T (2.92 mm), SSR, 9 kHz to 43.5 GHz, absorptive, n = 2 to 4	R&S®OSP-B164K	1528.1660.4n
<b>Auxiliary modules</b>		
n × digital RF attenuator (2.92 mm female), 9 kHz to 40 GHz, n = 2 or 4	R&S®OSP-B171H	1528.1577.4n
<b>Components for system applications</b>		
Relay driver module, control of four external RF power relays, additional digital inputs/outputs, interlock	R&S®OSP-B104	1505.5401.02
EMS module for small systems (DPDT, SPDT, interlock, digital I/O)	R&S®OSP-B114	1505.4711.02
Digital I/O module, 16 × digital inputs, 16 × digital outputs	R&S®OSP-B103	1505.5301.02
Multiplexer module, six-channel, four-wire multiplexer	R&S®OSP-B108	1505.5718.02
Passive module for integration of one Rohde & Schwarz USB power sensor (see page 46)	R&S®OSP-PM-I	1515.5985.02
Module kit for R&S®OSP320 <sup>44, 45, 46</sup>	R&S®OSP-BCST	1528.3257.02
Load unit, 2 RU	R&S®OSP-BL01	1528.3270.02

## RF feedthroughs for R&S®OSP base units

Module panel with 12 × SMA mounting holes	R&S®OSP-B011	1505.4763.02
Module panel with 4 × N mounting holes	R&S®OSP-B012	1505.4770.02
Cable set (4 × RF cables, N female to N female), DC to 12.4 GHz	R&S®OSP-Z010	1505.4534.02
Cable set (4 × RF cables, N female to SMA female), DC to 12.4 GHz	R&S®OSP-Z011	1505.4540.02
Cable set (4 × RF cables, SMA female to SMA female), DC to 18 GHz	R&S®OSP-Z012	1505.4557.02

<sup>43</sup> Reflective DP3T relays with external termination (30 dBm).

<sup>44</sup> Delivery expected from January 2025, subject to change without notice.

<sup>45</sup> R&S®OSP320 with serial number ≥ 102 000 required.

<sup>46</sup> The R&S®OSP-BCST is not pre-installed, i.e. not mounted into the R&S®OSP320 base unit.

## Accessories for R&S®OSP base units

Recommended extras for installation in 19" racks		
19" rack adapter, 2 RU, for R&S®OSP220, R&S®OSP230	R&S®ZZA-KNA21	1177.8026.00
19" rack adapter, 3 RU, for R&S®OSP320	R&S®ZZA-KNA31	1177.8032.00

## Accessories for R&S®OSP modules

<p>SMA wrench for easier assembly</p> <p>8 mm wrench for RF cables with SMA to 1 mm connector (m), with knurled wheel for manual preassembly and hexagonal bolt for usage with torque wrench (torque wrench not included), total length: 178 mm (without cable colliding: 113 mm)</p> 	R&S®SMA-WRENCH	1528.1590.02
---	----------------	--------------

## Accessories for R&S®OSP satellite box (R&S®OSP-B200S2)

Remote control module for R&S®OSP-B200S2 satellite box, with electrical interface (wired link)	R&S®OSP-B200R	1528.3140.02
Remote control module for R&S®OSP-B200S2 satellite box, with fiber-optic link (FOL) interface and electrical interface		1528.3140.04
AC power supply for R&S®OSP-B200S2 satellite box (required for FOL interface)	R&S®OSP-B200P	1528.3205.02

## Cables between R&S®OSP-B200R and R&S®OSP-B200S2

Electrical bus cable, length: 5 m	R&S®OSP-Z200A	1528.3170.02
Electrical bus cable, length: 10 m	R&S®OSP-Z200B	1528.3170.04
Fiber-optic link (FOL), SC to SC		
Length: 5 m	R&S®OSP-Z201A	1528.3186.02
Length: 10 m	R&S®OSP-Z201B	1528.3186.04
Length: 20 m	R&S®OSP-Z201C	1528.3186.06
Length: 30 m	R&S®OSP-Z201D	1528.3186.08
Length: 40 m	R&S®OSP-Z201E	1528.3186.10
Fiber-optic link (FOL), SC to FSMA		
Length: 0.5 m	R&S®OSP-Z203XF	1528.1690.02
Length: 1 m	R&S®OSP-Z203YF	1528.1690.03
Length: 3 m	R&S®OSP-Z203ZF	1528.1690.04
Length: 5 m	R&S®OSP-Z203AF	1528.1690.05
Length: 10 m	R&S®OSP-Z203BF	1528.1690.10
Length: 20 m	R&S®OSP-Z203CF	1528.1690.20
Length: 30 m	R&S®OSP-Z203DF	1528.1690.30
Length: 40 m	R&S®OSP-Z203EF	1528.1690.40
Fiber-optic link (FOL), FSMA to FSMA		
Length: 0.5 m	R&S®OSP-Z204XF	1528.1702.02
Length: 1 m	R&S®OSP-Z204YF	1528.1702.03
Length: 3 m	R&S®OSP-Z204ZF	1528.1702.04
Length: 5 m	R&S®OSP-Z204AF	1528.1702.05
Length: 10 m	R&S®OSP-Z204BF	1528.1702.10
Length: 20 m	R&S®OSP-Z204CF	1528.1702.20
Length: 30 m	R&S®OSP-Z204DF	1528.1702.30
Length: 40 m	R&S®OSP-Z204EF	1528.1702.40

## Service options for R&S®OSP <sup>47</sup>

Extended warranty, one year	R&S®WE1	The warranty depends of the R&S®OSP configuration. Contact your local Rohde & Schwarz sales office.
Extended warranty, two years	R&S®WE2	
Extended warranty, three years	R&S®WE3	
Extended warranty, four years	R&S®WE4	
Extended warranty with calibration coverage, one year	R&S®CW1	
Extended warranty with calibration coverage, two years	R&S®CW2	
Extended warranty with calibration coverage, three years	R&S®CW3	
Extended warranty with calibration coverage, four years	R&S®CW4	
Extended warranty with accredited calibration coverage, one year	R&S®AW1	
Extended warranty with accredited calibration coverage, two years	R&S®AW2	
Extended warranty with accredited calibration coverage, three years	R&S®AW3	
Extended warranty with accredited calibration coverage, four years	R&S®AW4	

### Extended warranty with a term of one to four years (WE1 to WE4) <sup>48</sup>

Repairs carried out during the contract term are free of charge <sup>49</sup>. Necessary calibration and adjustments carried out during repairs are also covered. Simply contact the forwarding agent we name; your product will be picked up free of charge and returned to you in top condition a couple of days later.

### Extended warranty with calibration (CW1 to CW4) <sup>48</sup>

Enhance your extended warranty by adding calibration coverage at a package price. This package ensures that your Rohde & Schwarz product is regularly calibrated, inspected and maintained during the term of the contract. It includes all repairs <sup>49</sup> and calibration at the recommended intervals as well as any calibration carried out during repairs or option upgrades.

### Extended warranty with accredited calibration (AW1 to AW4) <sup>48</sup>

Enhance your extended warranty by adding accredited calibration coverage at a package price. This package ensures that your Rohde & Schwarz product is regularly calibrated under accreditation, inspected and maintained during the term of the contract. It includes all repairs <sup>49</sup> and accredited calibration at the recommended intervals as well as any accredited calibration carried out during repairs or option upgrades.

Contact your local Rohde & Schwarz sales office for more information.

The terms HDMI and HDMI High-Definition Multimedia Interface, and the HDMI Logo are trademarks or registered trademarks of HDMI Licensing LLC in the United States and other countries.

<sup>47</sup> System modules (R&S®OSP-B15x, e.g. R&S®OSP-B157) need a separate warranty, calibration and DKD option.

<sup>48</sup> The costs for the extended warranty comply with the list price of the R&S®OSP configuration.

<sup>49</sup> Excluding defects caused by incorrect operation or handling and force majeure. Wear-and-tear parts are not included.







**Service at Rohde & Schwarz**  
**You're in great hands**

- ▶ Worldwide
- ▶ Local and personalized
- ▶ Customized and flexible
- ▶ Uncompromising quality
- ▶ Long-term dependability

**Rohde & Schwarz**

The Rohde&Schwarz technology group is among the trail-blazers when it comes to paving the way for a safer and connected world with its leading solutions in test & measurement, technology systems and networks & cybersecurity. Founded 90 years ago, the group is a reliable partner for industry and government customers around the globe. The independent company is headquartered in Munich, Germany and has an extensive sales and service network with locations in more than 70 countries.

[www.rohde-schwarz.com](http://www.rohde-schwarz.com)

**Sustainable product design**

- ▶ Environmental compatibility and eco-footprint
- ▶ Energy efficiency and low emissions
- ▶ Longevity and optimized total cost of ownership

Certified Quality Management

**ISO 9001**

Certified Environmental Management

**ISO 14001**

**Rohde & Schwarz training**

[www.training.rohde-schwarz.com](http://www.training.rohde-schwarz.com)

**Rohde & Schwarz customer support**

[www.rohde-schwarz.com/support](http://www.rohde-schwarz.com/support)

