

R&S® AREG800A

Automotive Radar Echo Generator

Getting Started



1179360902
Version 05

ROHDE & SCHWARZ
Make ideas real



This document describes the R&S®AREG800A, stock no. 1437.4400.02.

© 2023 Rohde & Schwarz

Muehldorfstr. 15, 81671 Muenchen, Germany

Phone: +49 89 41 29 - 0

Email: info@rohde-schwarz.com

Internet: www.rohde-schwarz.com

Subject to change – data without tolerance limits is not binding.

R&S® is a registered trademark of Rohde & Schwarz GmbH & Co. KG.

All other trademarks are the properties of their respective owners.

1179.3609.02 | Version 05 | R&S®AREG800A

Throughout this manual, products from Rohde & Schwarz are indicated without the ® symbol, e.g. R&S®AREG800A is indicated as R&S AREG800A and R&S®QAT100 is indicated as R&S QAT100.

Contents

1 Safety and regulatory information.....	5
1.1 Safety instructions.....	5
1.2 Labels on R&S AREG800A.....	8
1.3 Warning messages in the documentation.....	9
1.4 Where to find key documents on Rohde & Schwarz.....	9
1.5 Korea certification class A.....	10
2 Documentation overview.....	11
2.1 Getting started manual.....	11
2.2 User manual and help.....	11
2.3 Printed safety instructions.....	11
2.4 Data sheet.....	12
2.5 Release notes and open-source acknowledgment (OSA).....	12
3 Key features.....	13
4 Preparing for use.....	14
4.1 Lifting and carrying.....	14
4.2 Unpacking and checking.....	14
4.3 Choosing the operating site.....	15
4.4 Setting up the R&S AREG800A.....	15
4.5 Considerations for test setup.....	17
4.6 Connecting to power.....	19
4.7 Connecting to LAN.....	19
4.8 Connecting USB devices.....	20
4.9 Connecting to RF coaxial connectors.....	21
4.10 Connecting the R&S QAT100.....	23

4.11	Connecting to Ref In/Ref Out.....	24
4.12	Connecting to Digital IO DD.....	25
4.13	Connecting to Aux IF In/Aux IF Out.....	26
4.14	Connecting a TRX frontend.....	26
4.15	Switching on or off.....	28
5	Instrument tour.....	30
5.1	Front panel tour.....	30
5.2	Rear panel tour.....	36
6	Trying out the instrument.....	43
6.1	Configuring static operation setups.....	43
6.2	Saving and recalling settings.....	45
7	Instrument control.....	48
7.1	Possible ways to operate the instrument.....	48
7.2	Means of manual interaction.....	49
7.3	Understanding the display information.....	49
7.4	Accessing the functionality.....	54
7.5	Entering data.....	55
7.6	Getting information and help.....	57
7.7	Remote control.....	58
7.8	Remote operation over VNC.....	59
7.9	Remote operation over web UI.....	60
8	Contacting customer support.....	62
	Index.....	63

1 Safety and regulatory information

The product documentation helps you use the product safely and efficiently. Follow the instructions provided here and in the following chapters.

Intended use

The product generates radio frequency (RF) signals for the development, production and verification of electronic components, modules or devices. The product is intended for industrial use, for example for production and conformance testing, maintenance and engineering laboratories.

Use the product only for its designated purpose. Any other use is considered improper use. Observe the operating conditions and performance limits stated in the data sheet.

Target audience

This document targets at all users, including technicians, operators, administrators and maintenance personnel. The required skills and experience of the users depend on the test setup and application of the product.

Where do I find safety information?

Safety information is part of the product documentation. It warns you of potential dangers and gives instructions on how to prevent personal injury or damage caused by dangerous situations. Safety information is provided as follows:

- In [Chapter 1.1, "Safety instructions"](#), on page 5. The same information is provided in many languages as printed "Safety Instructions". The printed "Safety Instructions" are delivered with the product.
- Throughout the documentation, safety instructions are provided when you need to take care during setup or operation.

1.1 Safety instructions

Products from the Rohde & Schwarz group of companies are manufactured according to the highest technical standards. To use the products safely, follow the instructions provided here and in the product documentation. Keep the product documentation nearby and offer it to other users.

Safety instructions

Use the product only for its intended use and within its performance limits. Intended use and limits are described in the product documentation such as the data sheet, manuals and the printed "Safety Instructions". If you are unsure about the appropriate use, contact Rohde & Schwarz customer service.

Using the product requires specialists or specially trained personnel. These users also need sound knowledge of at least one of the languages in which the user interfaces and the product documentation are available.

Reconfigure or adjust the product only as described in the product documentation or the data sheet. Any other modifications can affect safety and are not permitted.

Never open the casing of the product. Only service personnel authorized by Rohde & Schwarz are allowed to repair the product. If any part of the product is damaged or broken, stop using the product. Contact Rohde & Schwarz customer service at <https://www.rohde-schwarz.com/support>.

Lifting and carrying the product

The product is heavy. Do not move or carry the product by yourself. A single person can only carry a maximum of 18 kg safely depending on age, gender and physical condition. Look up the maximum weight in the data sheet. Use the product handles to move or carry the product. Do not lift by the accessories mounted on the product. Accessories are not designed to carry the weight of the product.

To move the product safely, you can use lifting or transporting equipment such as lift trucks and forklifts. Follow the instructions provided by the equipment manufacturer.

Choosing the operating site

Only use the product indoors. The product casing is not waterproof. Water that enters can electrically connect the casing with live parts, which can lead to electric shock, serious personal injury or death if you touch the casing. If Rohde & Schwarz provides accessories designed for your product, e.g. a carrying bag, you can use the product outdoors.

Unless otherwise specified, you can operate the product up to an altitude of 2000 m above sea level. The product is suitable for pollution degree 2 environments where nonconductive contamination can occur. For more information on environmental conditions such as ambient temperature and humidity, see the data sheet.

Setting up the product

Always place the product on a stable, flat and level surface with the bottom of the product facing down. If the product is designed for different positions, secure the product so that it cannot fall over.

If the product has foldable feet, always fold the feet completely in or out to ensure stability. The feet can collapse if they are not folded out completely or if the product is moved without lifting it. The foldable feet are designed to carry the weight of the product, but not an extra load.

If stacking is possible, keep in mind that a stack of products can fall over and cause injury.

If you mount products in a rack, ensure that the rack has sufficient load capacity and stability. Observe the specifications of the rack manufacturer. Always install the products from the bottom shelf to the top shelf so that the rack stands securely. Secure the product so that it cannot fall off the rack.

Connecting to power

The product is an overvoltage category II product. Connect the product to a fixed installation used to supply energy-consuming equipment such as household appliances and similar loads. Keep in mind that electrically powered products have risks, such as electric shock, fire, personal injury or even death. Replace parts that are relevant to safety only by original parts, e.g. power cables or fuses.

Take the following measures for your safety:

- Before switching on the product, ensure that the voltage and frequency indicated on the product match the available power source. If the power adapter does not adjust automatically, set the correct value and check the rating of the fuse.
- Only use the power cable delivered with the product. It complies with country-specific safety requirements. Only insert the plug into an outlet with protective conductor terminal.
- Only use intact cables and route them carefully so that they cannot be damaged. Check the power cables regularly to ensure that they are undamaged. Also ensure that nobody can trip over loose cables.
- If you connect the product to an external power supply, use the one delivered with the product or recommended in the product documentation. The external power supply must conform to the country-specific regulations.

Labels on R&S AREG800A





- Only connect the product to a power source with a fuse protection of maximum 20 A.
- Ensure that you can disconnect the product from the power source at any time. Pull the power plug to disconnect the product. The power plug must be easily accessible. If the product is integrated into a system that does not meet these requirements, provide an easily accessible circuit breaker at the system level.

Cleaning the product

Use a dry, lint-free cloth to clean the product. When cleaning, keep in mind that the casing is not waterproof. Do not use liquid cleaning agents.

Meaning of safety labels

Safety labels on the product warn against potential hazards.

	<p>Potential hazard</p> <p>Read the product documentation to avoid personal injury or product damage.</p>
	<p>Heavy product</p> <p>Be careful when lifting, moving or carrying the product. Carrying the product requires a sufficient number of persons or transport equipment.</p>
	<p>Electrical hazard</p> <p>Indicates live parts. Risk of electric shock, fire, personal injury or even death.</p>
	<p>Hot surface</p> <p>Do not touch. Risk of skin burns. Risk of fire.</p>
	<p>Protective conductor terminal</p> <p>Connect this terminal to a grounded external conductor or to protective ground. This connection protects you against electric shock if an electric problem occurs.</p>

1.2 Labels on R&S AREG800A

Labels on the casing inform about:

- Personal safety, see ["Connecting to power"](#) on page 7.
- Product and environment safety, see [Table 1-1](#).
- Identification of the product, see the serial number on the [rear panel](#).

Table 1-1: Labels regarding R&S AREG800A and environment safety

	Labeling in line with EN 50419 for disposal of electrical and electronic equipment after the product has come to the end of its service life. For more information, see the product user manual, chapter "Disposal".
---	--

1.3 Warning messages in the documentation

A warning message points out a risk or danger that you need to be aware of. The signal word indicates the severity of the safety hazard and how likely it will occur if you do not follow the safety precautions.

WARNING

Potentially hazardous situation. Could result in death or serious injury if not avoided.

CAUTION

Potentially hazardous situation. Could result in minor or moderate injury if not avoided.

NOTICE

Potential risks of damage. Could result in damage to the supported product or to other property.

1.4 Where to find key documents on Rohde & Schwarz

Certificates issued to Rohde & Schwarz that are relevant for your country are provided at www.rohde-schwarz.com/key-documents, e.g. concerning:

- Quality management
- Environmental management
- Information security management
- Accreditations

1.5 Korea certification class A



이 기기는 업무용(A급) 전자파 적합기기로서 판매자 또는 사용자는 이 점을 주의하시기 바라며, 가정외의 지역에서 사용하는 것을 목적으로 합니다.

2 Documentation overview

This section provides an overview of the R&S AREG800A user documentation.

2.1 Getting started manual

Introduces the R&S AREG800A and describes how to set up and start working with the product. Includes basic operations, typical measurement examples, and general information, e.g. safety instructions, etc. A printed version is delivered with the instrument.

2.2 User manual and help

The user manual contains the description of all instrument modes and functions. It also provides an introduction to remote control, a complete description of the remote control commands with programming examples, and information on maintenance, instrument interfaces and error messages. Includes the contents of the getting started manual.

The contents of the user manual are available as help in the R&S AREG800A. The help offers quick, context-sensitive access to the complete information for the instrument and its firmware.

The user manual is also available for download or for immediate display on the Internet.

2.3 Printed safety instructions

Provides safety information in many languages. The printed document is delivered with the product.

2.4 Data sheet

The data sheet contains the technical specifications of the R&S AREG800A. It also lists the firmware applications and their order numbers, and optional accessories.

2.5 Release notes and open-source acknowledgment (OSA)

The release notes list new features, improvements and known issues of the current firmware version, and describe the firmware installation.

The software makes use of several valuable open source software packages. An open-source acknowledgment document provides verbatim license texts of the used open source software.

3 Key features

The R&S AREG800A is a new high performance Automotive Radar Echo Generator developed to meet demanding customer requirements. Offering excellent radar signal characteristics, wide radar signal bandwidth and straightforward and intuitive operation, the R&S AREG800A makes radar signal generation fast and easy.

Outstanding key features of the R&S AREG800A are:

- Simulation of echoes of stationary and highly dynamic objects
- Simulation of echoes with extremely short object distances
- Simulation of echoes of multiple independent objects
- Azimuth simulation with R&S QAT100
- IF signals with high instantaneous bandwidth
- Scalable solution from production test needs to road-ready vehicle simulators
- Fully harmonized with external frontends for a wide range of echo complexity
- Built-in real-time interface for dynamic scenario simulation
- Support of scenario simulation tools: DYNA4 from Vector, Open Simulation Interface (OSI)
- Synchronization of multiple instruments of the R&S AREG800A and R&S QAT100

For more information, see data sheet.

4 Preparing for use

Here, you can find basic information about setting up the product for the first time.

4.1 Lifting and carrying

Use the handles at the side, for lifting and carrying the R&S AREG800A, see "[Lifting and carrying the product](#)" on page 6. Use the handles at the front, for mounting the R&S AREG800A in a rack.

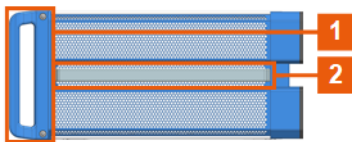

Figure 4-1: Instrument side view with front handles (1) and side handles (2)

4.2 Unpacking and checking

1. Unpack the R&S AREG800A carefully.
2. Retain the original packing material. Use it to protect the control elements and connectors when transporting or shipping the R&S AREG800A later. See also chapter "Transporting" in the user manual.
3. Using the delivery notes, check the equipment for completeness.
4. Check the equipment for damage.

If the delivery is incomplete or equipment is damaged, contact Rohde & Schwarz.

4.3 Choosing the operating site

Specific operating conditions ensure proper operation and avoid damage to the product and connected devices. For information on environmental conditions such as ambient temperature and humidity, see the data sheet.

For safety information, see "[Choosing the operating site](#)" on page 6.

Electromagnetic compatibility classes

The electromagnetic compatibility (EMC) class indicates where you can operate the product. The EMC class of the product is given in the data sheet.

- Class B equipment is suitable for use in:
 - Residential environments
 - Environments that are directly connected to a low-voltage supply network that supplies residential buildings
- Class A equipment is intended for use in industrial environments. It can cause radio disturbances in residential environments due to possible conducted and radiated disturbances. It is therefore not suitable for class B environments. If class A equipment causes radio disturbances, take appropriate measures to eliminate them.

4.4 Setting up the R&S AREG800A

See also:

- "[Setting up the product](#)" on page 7
- "[Intended use](#)" on page 5

4.4.1 Placing the R&S AREG800A on a bench top

To place the product on a bench top

1. Place the product on a stable, flat and level surface. Ensure that the surface can support the weight of the product. For information on the weight, see the data sheet.

Setting up the R&S AREG800A

2. **WARNING!** A stack of products can fall over and cause injury. Never stack more than two products. Otherwise, mount them in a rack.

Stack as follows:

- All products must have the same dimensions (width and length).
- Do not exceed a total load of 50 kg placed on the product at the bottom of the stack.

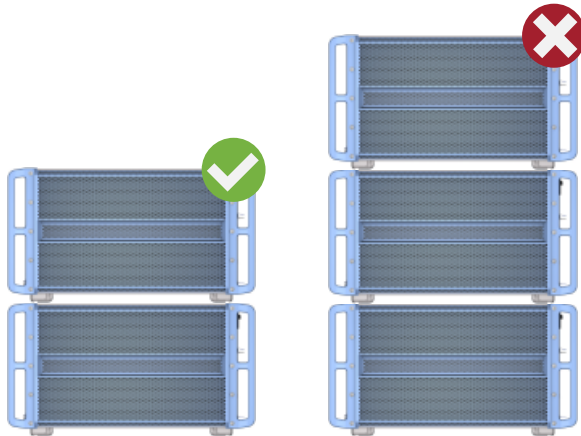

Left = Stacked correctly

Right = Stacked incorrectly, too many products

3. **NOTICE!** Overheating can damage the product.

Prevent overheating as follows:

- Keep a minimum distance of 10 cm between the fan openings of the product and any object in the vicinity to provide sufficient airflow and ventilation.
- Do not place the product next to heat-generating equipment such as radiators or other products.

4.4.2 Mounting the R&S AREG800A in a rack

To prepare the rack

1. Observe the requirements and instructions in "[Setting up the product](#)" on page 7.
2. **NOTICE!** Insufficient airflow can cause overheating and damage the product. Design and implement an efficient ventilation concept for the rack.

To mount the R&S AREG800A in a rack

1. Use an adapter kit that fits the dimensions of the R&S AREG800A to prepare the instrument for rack mounting.
 - a) Order the rack adapter kit designed for the R&S AREG800A. For the order number, see the data sheet.
 - b) Mount the adapter kit. Follow the assembly instructions provided with the adapter kit.
2. **WARNING!** The R&S AREG800A is heavy. Lift the R&S AREG800A with a lifting equipment, see "[Lifting and carrying the product](#)" on page 6.
Lift the R&S AREG800A to shelf height.
3. Grab the handles at the front.
4. Push the R&S AREG800A onto the shelf until the rack brackets fit closely to the rack.
5. Tighten all screws at the rack brackets with a tightening torque of 1.2 Nm to secure the R&S AREG800A in the rack.

To unmount the R&S AREG800A from a rack

1. Loosen the screws at the rack brackets.
2. **WARNING!** The R&S AREG800A is heavy. Lift the R&S AREG800A with a lifting equipment, see "[Lifting and carrying the product](#)" on page 6.
Bring the lifting equipment to shelf height.
3. Remove the R&S AREG800A from the rack.
4. If placing the R&S AREG800A on a bench top again, unmount the adapter kit from the R&S AREG800A. Follow the instructions provided with the adapter kit.

4.5 Considerations for test setup

Cable selection and electromagnetic interference (EMI)

Electromagnetic interference (EMI) can affect the measurement results.

To suppress electromagnetic radiation during operation:

- Use high-quality shielded cables, especially for the following connector types:
 - BNC
Double-shielded BNC cables.
How to: ["To connect to pluggable connectors"](#) on page 22
 - SMA
Double-shielded SMA cables.
How to: ["To connect to screwable connectors"](#) on page 22
 - USB
Double-shielded USB cables.
How to: [Chapter 4.8, "Connecting USB devices"](#), on page 20.
 - LAN
At least CAT6 STP cables.
How to: [Chapter 4.7, "Connecting to LAN"](#), on page 19
- Always terminate open cable ends.
- Ensure that connected external devices comply with EMC regulations.
- Use the cable G-SMA EF316 for the IF connection to the SMA connectors of the instrument and the R&S QAT100. The cable is included in the delivery of the R&S QAT100 and available under order number 1142.5889.00.
How to: ["To connect to SMA connectors"](#) on page 23
- Use the cables TRX CRTL Cable, IF TX CBL and IF RX CBL for connection of the instrument and the TRX frontend. The cables are included in the delivery of the TRX frontend and available under order number 1142.5889.00.
How to: ["To connect to SMA connectors"](#) on page 23

Signal input and output levels

Information on signal levels is provided in the data sheet. Keep the signal levels within the specified ranges to avoid damage to the R&S AREG800A and connected devices.

Preventing electrostatic discharge (ESD)

Electrostatic discharge is most likely to occur when you connect or disconnect a DUT.

- ▶ **NOTICE!** Electrostatic discharge can damage the electronic components of the product and the device under test (DUT).

Ground yourself to prevent electrostatic discharge damage:

- a) Use a wrist strap and cord to connect yourself to ground.
- b) Use a conductive floor mat and heel strap combination.

Over-the-air (OTA) tests

For over-the-air (OTA) tests, operate R&S AREG800A in shielded environment.

For more information, see data sheet.

4.6 Connecting to power

For safety information, see "[Connecting to power](#)" on page 7.

1. Plug the AC power cable into the AC power connector on the rear panel. Only use the AC power cable delivered with the R&S AREG800A.
2. Plug the AC power cable into a power outlet with ground contact.

The required ratings are listed next to the AC power connector and in the data sheet.

4.7 Connecting to LAN

Network environment

Before connecting the product to a local area network (LAN), consider the following:

- Install the latest firmware to reduce security risks.
- For internet or remote access, use secured connections if applicable.
- Ensure that the network settings comply with the security policies of your company. Contact your local system administrator or IT department before connecting your product to your company LAN.
- When connected to the LAN, the product may potentially be accessed from the internet, which may be a security risk. For example, attackers might misuse or damage the product.

To connect to LAN

- ▶ Connect the LAN socket on the rear panel via an RJ-45 cable to the LAN. Using DHCP (dynamic host configuration protocol), the R&S AREG800A assigns the IP address automatically.

If connected to the LAN, the R&S AREG800A displays the IP address and the hostname at the left bottom of the home screen.

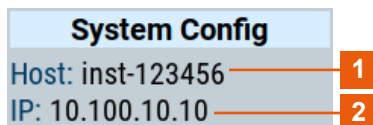

1 = Hostname
2 = IP address

If disconnected from the LAN, the R&S AREG800A displays the IP address *0.0.0.0*.

See also chapter "To configure the instrument for remote access" in the user manual.

4.8 Connecting USB devices

You can connect or disconnect all USB devices from the R&S AREG800A during operation.

To connect USB storage devices

USB storage devices, such as memory sticks, allow data transfer from or to the R&S AREG800A. You can also use them for firmware updates.

- ▶ Connect the USB storage device to any of the USB connectors.

To connect USB devices with external power supply

1. **NOTICE!** Connected devices with external power supply can feed back current into the 5 V power supply of the USB interface and thus damage the R&S AREG800A.

Ensure that there is no connection between the positive pole of the power supply and the +5 V power pin of the USB interface (VBUS).

Connecting to RF coaxial connectors

2. Connect the USB storage device to any of the USB connectors on the front panel or rear panel.

To connect a keyboard

- ▶ Connect the keyboard to any of the USB connectors on the front panel or rear panel.

When connected, the R&S AREG800A detects the keyboard automatically. A detected keyboard has the default layout English – US.

To connect a mouse

- ▶ Connect the mouse to any of the USB connectors.

When connected, the R&S AREG800A detects the mouse automatically.

To connect power sensors

Connect power sensors of the R&S NRP families to any of the USB connectors on the front panel or rear panel.

See chapter "Using power sensors" in the user manual.

4.9 Connecting to RF coaxial connectors

Here, you find information on how to prepare and to connect to RF coaxial connectors of the R&S AREG800A. Use these RF connectors, for example, for output of the RF signal or for input of an external reference signal.

To prepare for connecting

1. **NOTICE!** Damaged or not clean connections can lead to RF insertion loss and mismatch, and even premature wear of the connectors.
Before connecting to the port, inspect the RF connector visually. Check that it is clean, undamaged and mechanically compatible.
2. **NOTICE!** DC voltage at the RF connector can damage the instrument. Never apply DC voltage to the RF input connectors.
Make sure that the values are within the DC limits given in the data sheet.
3. If your test setup has a DC component at the RF input, insert a DC blocker.

Connecting to RF coaxial connectors

4. Use a high-quality RF cable that matches the RF connector type.
See "[Cable selection and electromagnetic interference \(EMI\)](#)" on page 17.
5. You can connect to two kinds of connectors:
 - "[To connect to screwable connectors](#)" on page 22
 - "[To connect to pluggable connectors](#)" on page 22

To connect to screwable connectors

The R&S AREG800A provides screwable RF connectors as in [Table 4-1](#).

- **NOTICE!** Excessive tightening can damage the connectors.

To connect the cable with the connector, proceed as follows:

- a) Carefully align the connector of the cable and the connector along a common axis.
- b) Mate the connectors along the common axis until the male pin of the inner connector engages with the female socket of the outer connector.
- c) Turn the nut of the outer connector until the connectors are firmly coupled.
- d) Using a calibrated torque wrench torque the nut to the limit as in the table below. Hold the opposite connector part stationary with a spanner.

Table 4-1: Connector name, type, size, torque limit and nut opening

Connector		Torque limit		Nut opening	
Type	Name	lb-Inch	Nm	Inch	mm
SMA	Ext Clk In	5	0.56	5/16	8
	Sync In				
	Sync Out				
	Aux IF In				
	Aux IF Out				
	Rx IF In				
	Rx IF Out				
	Tx IF In				
	Tx IF Out				

To connect to pluggable connectors

The R&S AREG800A provides pluggable Bayonet Neill-Concelman (BNC) connectors.

- To connect the RF cable with the BNC connector, proceed as follows:
- a) Carefully align the connector of the cable and the BNC connector along a common axis.

Connecting the R&S QAT100

- b) Mate the connectors along the common axis until the male pin of the connector of the cable engages with the female socket of the BNC connector.

For information on how to handle and maintain the RF port, to minimize measurement deviations and ensure its longevity, see the application note [1MA99](#).

If you want to mount test port adapters to your RF connector, see the application note [1MA100](#).

4.10 Connecting the R&S QAT100

The R&S AREG800A can generate radar signals when connected to an external frontend, e.g. the R&S QAT100. This section provides information on relevant connections between R&S AREG800A and the R&S QAT100.

To connect to SMA connectors

For IF signal input and output the R&S AREG800A provides SMA connectors.

1. Before connecting, prepare the SMA connectors on the rear panel. See "[To prepare for connecting](#)" on page 21.
2. Connect to the SMA connectors of the R&S AREG800A with the R&S QAT100. See "[To connect to screwable connectors](#)" on page 22.

You have several options. [Table 4-2](#) provides an example on relevant connections.

To connect to System Control

- ▶ Connect the socket of the "System Control" connector with an RJ-45 cable to the "LAN" connector of the R&S QAT100. See [Chapter 4.7, "Connecting to LAN"](#), on page 19.

[Table 4-2](#) provides an overview on relevant connections.

Table 4-2: Connection between R&S AREG800A and R&S QAT100

Signal (direction)	R&S AREG800A connector	R&S QAT100 connector
IF out (Tx)	"Tx IF Out 1"	"Tx Σ"
IF in (Rx)	"Rx IF In 1"	"Rx Select"
Control (LAN)	"System Control"	"LAN"

To disconnect the R&S QAT100

1. **NOTICE!** If you connect or disconnect the control cable while the base unit is powered on, you can damage the R&S AREG800A.
Switch off the R&S AREG800A, see ["To shut down the product"](#) on page 29.
2. Disconnect the SMA connections between R&S AREG800A and R&S QAT100:
 - a) Untorque the nut using a calibrated torque wrench. Hold the opposite connector part stationary with a spanner.
 - b) Turn the nut of the outer connector until the connectors are detached.
3. To disconnect the connection cable:
 - a) Hold the connector at the sleeve.
 - b) To release the lock, pull the sleeve without turning.
Do not pull the cable.

4.11 Connecting to Ref In/Ref Out

To connect to "Ref In"/"Ref Out"

1. Before connecting, prepare the "Ref In"/"Ref Out" connectors on the rear panel. See ["To prepare for connecting"](#) on page 21.
2. Connect to the "Ref In"/"Ref Out" connectors. See ["To connect to pluggable connectors"](#) on page 22.

4.12 Connecting to Digital IO DD

The Digital IO DD connector comprises a QSFP+ (Quad Small Form-factor Pluggable) socket that has two components: a QSFP+ cage and a QSFP+ connector. The QSFP+ cable is equipped with the QSFP+ plug.

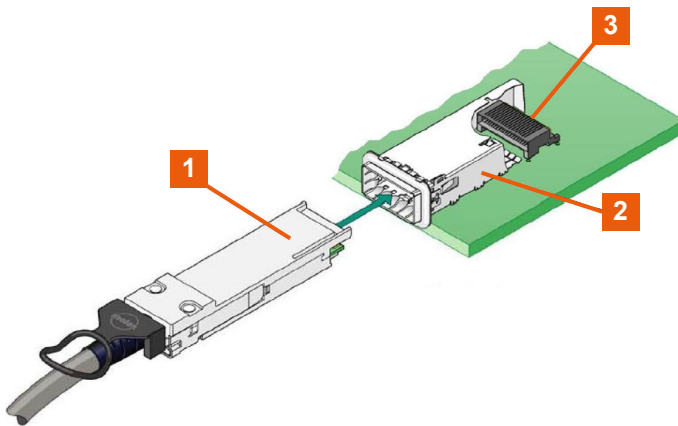

- 1 = QSFP+ plug
- 2 = QSFP+ cage
- 3 = QSFP+ connector

To connect to Digital IO DD interface

1. For connection, use the QSFP+ cable R&S DIGIQ-HS.
See "[Cable selection and electromagnetic interference \(EMI\)](#)" on page 17.
2. Hold the QSFP+ plug of the cable by its panes.
3. Turn the QSFP+ cable, so that the release tab shows upwards.
4. Insert and push the QSFP+ plug into the QSFP+ cage.

To disconnect from Digital IO DD interface

1. **NOTICE!** If you pull the cable, you can damage the cable and the Digital IO DD connector.
Pull the release tab.
2. Pull the QSFP+ plug out of the QSFP+ cage.

4.13 Connecting to Aux IF In/Aux IF Out

See ["To connect to SMA connectors"](#) on page 23.

4.14 Connecting a TRX frontend

The TRX frontend is delivered with two IF cables (IF TX CBL/IF RX CBL) and one control cable (TRX CRTL Cable). These cables are calibrated and dedicated to the particular TRX frontend. Each cable has its own serial number, printed on it.

To connect the "IF TX CBL"/"IF RX CBL" cables

1. Take the **"IF TX CBL"** cable delivered with the TRX frontend.
See ["To check the serial number of the cables"](#) on page 28.
2. Connect the "Tx IF Out" connector of the base unit to "Tx IF In" connector of the TRX frontend.
Follow the instructions in [Chapter 4.13, "Connecting to Aux IF In/Aux IF Out"](#), on page 26.
This connection carries the IF signal for the transmitting antenna and the reference signal for the TRX frontend.
3. Take the **"IF RX CBL"** cable delivered with the TRX frontend.
4. Connect the "Rx IF Out" connector of the TRX frontend to "Rx IF In" connector of the base unit.
Follow the instructions in [Chapter 4.13, "Connecting to Aux IF In/Aux IF Out"](#), on page 26.
This connection carries the IF signal of the receiving antenna for the base unit.
5. **NOTICE!** Excessive bending can damage the cables.
Bend the "IF TX CBL"/"IF RX CBL" to a max. bending radius of 50 mm.

To connect the TRX CRTL Cable cable

1. **NOTICE!** If you connect or disconnect the control cable while the base unit is powered on, you can damage the R&S AREG800A.
Switch off the base unit.
See ["To shut down the product"](#) on page 29.

Connecting a TRX frontend

2. Take the **TRX CRTL Cable** cable delivered with the TRX frontend.
See ["To check the serial number of the cables"](#) on page 28.
3. Hold the connector at the sleeve so that the red dot is upwards.
4. Align the connector of the cable along a common axis.
5. Plug the control cable at the "Control" connector at the base unit.
The sleeve locks.
6. Plug the control cable at the "Control" connector at the TRX frontend.
The sleeve locks.
7. **NOTICE!** Excessive bending can damage the cables.
Bend the "TRX CRTL Cable" to a maximum bending radius of 50 mm.

To operate the TRX frontend

1. Switch on the base unit.
See ["To shut down the product"](#) on page 29.
2. **CAUTION!** Hot surface, see ["Meaning of safety labels"](#) on page 8.
Hold the TRX frontend by its sides.
Do not touch the waveguide surface. Depending on the ambient temperature, this surface can become hot.
3. **NOTICE!** Overheating can damage the product.
Prevent overheating as follows:
 - Do not cover the TRX frontend module with thermally insulating material while the R&S AREG800A is switched on.
 - See also [Chapter 4.4.1, "Placing the R&S AREG800A on a bench top"](#), on page 15.

To disconnect the TRX frontend

1. **NOTICE!** If you connect or disconnect the control cable while the base unit is powered on, you can damage the R&S AREG800A.
Switch off the base unit.
See ["To shut down the product"](#) on page 29.
2. To disconnect the "IF TX CBL"/"IF RX CBL" cables, proceed as follows for each of the four connections:
 - a) Untorque the nut using a calibrated torque wrench. Hold the opposite connector part stationary with a spanner.

- b) Turn the nut of the outer connector until the connectors are detached.
3. To disconnect the "TRX CRTL Cable":
 - a) Hold the connector at the sleeve.
 - b) To release the lock, pull the sleeve without turning.
Do not pull the cable.



To check the serial number of the cables

1. Switch on the base unit.
See [Chapter 4.15, "Switching on or off"](#), on page 28.
2. On the front panel, press [Setup].
3. Select "Setup" > "Instrument Assembly" > "Hardware Config" > "RF Assembly".
4. For each cable, compare the displayed serial number with the serial number printed on the cable.

4.15 Switching on or off

The following table provides an overview of power states, LEDs and positions of the power switch.

Table 4-3: Overview of power states

State	LED	Position of power switch
Off	 gray	[0]
Standby	 orange	[I]
Ready	 green	[I]

To switch on the R&S AREG800A

The R&S AREG800A is off but connected to power. See [Chapter 4.6, "Connecting to power"](#), on page 19.

1. Set the switch on the power supply to position [I] on the rear panel.
The LED of the [On/Standby] key on the front panel is orange.
2. Press the [On/Standby] key on the front panel.

The LED changes to green. The R&S AREG800A boots.

After booting, the R&S AREG800A starts up displaying the home screen on the screen on the front panel.

To check start-up functions

When starting for the first time, the R&S AREG800A starts with the default settings. When restarting, the R&S AREG800A recalls the instrument configuration before shut-down.

See chapter "Saving and recalling instrument settings" in the user manual.

When switched on, the R&S SMW automatically monitors main functions. You can query erroneous functions. In addition to automatic monitoring, you can perform maintenance tasks. See the following:

- Chapter "Querying notifications" in the user manual.
- Chapter "Performing maintenance tasks" in the user manual.

To shut down the product

The product is in the ready state.

► Press the [On/Standby] key.

The operating system shuts down. The LED changes to orange.

In the standby state, the power switch circuits are active. To deactivate them, disconnect the instrument from the power supply.

To disconnect from power

The R&S AREG800A is in the standby state.

1. **NOTICE!** Risk of data loss. If you disconnect the product from power when it is in the ready state, you can lose settings and data. Shut it down first.

Set the toggle switch on the power supply to position [0].

The LED of the [On/Standby] key is switched off.

2. Disconnect the R&S AREG800A from the power source.

5 Instrument tour

This chapter explains the control elements and the connectors of the R&S AREG800A. The views of the front panel and the rear panel help you to get familiar with the instrument and to perform first steps. For specifications of the interfaces, see the data sheet.

The meanings of the labels on the R&S AREG800A are described in [Chapter 1.2, "Labels on R&S AREG800A"](#), on page 8.

5.1 Front panel tour

This section provides an overview of the control elements and connectors on the front panel of the R&S AREG800A. On the [rear panel](#), you find all further connectors of the unit. The user interface can be displayed on a remote PC station used to manually remote control the instrument.



Figure 5-1: R&S AREG800A front panel controls and connectors

- 1 = [Utility keys, page 32](#)
- 2 = [Touchscreen, page 31](#)
- 3 = [Function keys, page 33](#) and [Keypad, page 33](#)

- 4 = Navigation controls, page 34
- 5 = Display keys, page 35
- 6 = SD card slot, page 36
- 7 = USB, page 36
- 8 = Sensor, page 36
- 9 = On/Standby, page 32

5.1.1 Touchscreen

The most important settings are displayed on the screen on the front panel. The screen display also provides status and setting information and allows you to quickly reconfigure the signal flow. The screen is touch-sensitive, offering an alternative means of user interaction for quick and easy handling of the instrument.

The screen at the front panel is the graphical user interface. It shows the settings dialogs and parameters, see [Chapter 7.3, "Understanding the display information"](#), on page 49. The screen is touch-sensitive, offering an alternative means of user interaction for quick and easy handling of the instrument.

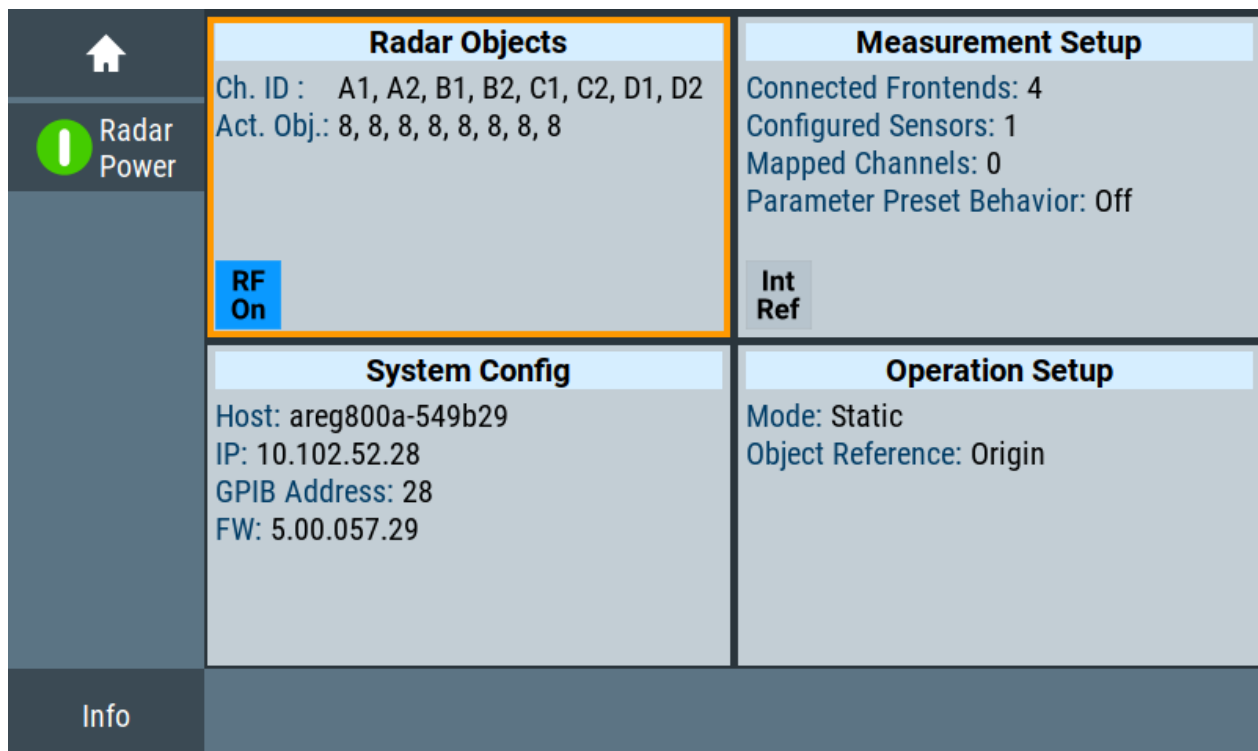

Figure 5-2: Touchscreen

Any user interface elements that react to a click by a mouse pointer also react to a tap on the screen, and vice versa. Using the touchscreen, you can perform the following tasks (among others) by the tap of your finger:

- Changing a setting
- Selecting new settings
- Scrolling through the list of parameters
- Saving or recalling settings
- Routing the signal flow
- Opening and closing dialogs

See also:

- [Chapter 7, "Instrument control"](#), on page 48, for operating the touchscreen.
- Chapter "Cleaning" in the user manual, for cleaning the touchscreen.

5.1.2 Keys

5.1.2.1 Utility keys

The utility keys cause the R&S AREG800A to return to a defined instrument state and provide information on the instrument and assistance.

Table 5-1: Utility keys

Utility key	Assigned functions
[Preset]	Sets the instrument to a defined state
[Local]	Switches from remote control to local (manual) control
[Setup]	Accesses the general instrument settings
[Help]	Displays context-sensitive help text

5.1.2.2 On/Standby

The [On/Standby] key switches the instrument from the standby to the ready state or vice versa.

The LED above the [On/Standby] key indicates the instrument state, see [Chapter 4.15, "Switching on or off"](#), on page 28.

5.1.2.3 Function keys

Function keys provide access to the most common generator settings and functions. You can find a detailed description of the corresponding functions in the user manual.

Table 5-2: Function keys

Function key	Assigned functions
[Freq]	Requires a connected external frontend, e.g., TRX frontends or an R&S QAT100. Opens the "Frontend Config" dialog and selects the "Frontend Center Frequency" of the connected external frontend. If several external frontends are connected, switches between the "Frontend Center Frequency" setting of the connected external frontends.
[Level]	Opens the "Radar Power" dialog, switches on or switches off selected radar channels.
[Mod On/Off]	Opens and closes the "Objects" dialog. In particular, selects the "Channel x" tab of the first available radar channel.
[RF On/Off]	Activates and deactivates all available radar objects of all radar channels.

5.1.2.4 Keypad

The keypad is used to enter alphanumeric parameters, including the corresponding units. It contains the following keys:

Table 5-3: Keys on the keypad

Type of key	Description
Alphanumeric keys	Enter numbers and (special) characters in edit dialog boxes.
Decimal point	Inserts a decimal point "." at the cursor position.
Sign key	Changes the sign of a numeric parameter. For an alphanumeric parameter, inserts a "-" at the cursor position.
Unit keys (G/n dB μ V, M/ μ μ V, k/m mV and x1 dB(m))	These keys add the selected unit to the entered numeric value and complete the entry. For level entries (e.g. in dB) or dimensionless values, all units have the value "1" as multiplying factor. Thus, they have the same function as an [Enter] key.

5.1.2.5 Navigation controls

The navigation controls include a rotary knob, navigation keys, and the display keys. They allow you to navigate within the display or within dialog boxes.

Rotary knob

The rotary knob has several functions:

- Increments (clockwise direction) or decrements (counterclockwise direction) the instrument parameter at a defined step width for a numeric entry.
- Moves the selection, e.g. to a function block in the block diagram
- Shifts the selection bar within focused areas (e.g. lists).
- Acts like the [Enter] key, when it is pressed.

Editing keys

Editing keys enable you to confirm an entry, delete individual characters, or exit the current operation.

Table 5-4: Editing keys

Type of key	Description
[Esc] key	<p>Closes all kinds of dialog boxes, if the edit mode is not active. Quits the edit mode, if the edit mode is active. In dialog boxes that contain a "Cancel" button it activates that button.</p> <p>For "Edit" dialog boxes, the following mechanism is used:</p> <ul style="list-style-type: none"> • If data entry has been started, it retains the original value and closes the dialog box. • If data entry has not been started or has been completed, it closes the dialog box.
[Enter] key	<p>Has the same effect as pressing the rotary knob</p> <ul style="list-style-type: none"> • Concludes the entry of dimensionless entries. The new value is accepted. • With other entries, this key can be used instead of the default unit key. • In a dialog box, selects the default or focused element. • Calls the next dialog level. • Confirms and closes open input windows.
[Backspace] key	Deletes the character to the left of the cursor in editing mode.

Navigation keys

The navigation keys can be used alternatively to the rotary knob to navigate through dialog boxes, diagrams, or tables.

Table 5-5: Navigation keys

Type of key	Description
[Up/Down] key	The [Up] and the [Down] key does the following: <ul style="list-style-type: none"> • In a numeric edit dialog box, increase or decrease the instrument parameter. • In a list, scroll forward and backward through the list entries. • In a table, move the selection bar vertically. • In windows or dialog boxes with vertical scrollbar, move the scrollbar.
[Left/Right] key	The [Left] and the [Right] key does the following: <ul style="list-style-type: none"> • In an alphanumeric edit dialog box, move the cursor. • In a list, scroll forward and backward through the list entries. • In a table, move the selection bar horizontally. • In windows or dialog boxes with horizontal scrollbar, move the scrollbar.

5.1.2.6 Display keys

The display keys arrange different windows on the display.

Table 5-6: Display keys

Display key	Assigned functions
[Home]	Returns to the initial feature screen.
[Next window]	Toggles between the entry fields in the taskbar.
[On/Off]	<ul style="list-style-type: none"> • Switches highlighted elements or a function block on and off. • Switches between two or more settings, e.g. items of selection lists. At the end of a list, the cursor is set on the first entry again.
[Undo]	Reverts the last operation.
[User]	Adds a parameter to the user menu for quick access.

5.1.3 Connectors

Various interface connectors are on the front panel of the R&S AREG800A.

SD card slot

SD card slot.

USB

Female USB (universal serial bus) 2.0 connector of type A, to connect devices like external USB devices, a mouse or a keyboard for enhanced operation.

You can also connect R&S NRP power sensors (with an R&S NRP-Z4 or an R&S NRP-ZKU adapter cable) for external power measurements. Also, you can connect a memory stick for software updates and data exchange.

Further USB connectors of type A are available on the rear panel.

How to: [Chapter 4.8, "Connecting USB devices"](#), on page 20

Sensor

Connector for R&S NRP sensors.

The connector is a six-pole ODU Mini-Snap® series B connector.

A power sensor is connected to the R&S AREG800A by inserting the male connector. To disconnect, pull the connector by its sleeve. You cannot disconnect the sensor simply by pulling at the cable or the rear part of the connector.

The R&S AREG800A supports the use of R&S NRP power sensors in various ways including the use as a power viewer.

How to: Chapter "Using Power Sensors" in the user manual

5.2 Rear panel tour

This section provides an overview of the connectors on the rear panel of the instrument. For technical data of the connectors, refer to the data sheet.



Figure 5-3: R&S AREG800A rear panel

- 1 = Connectors for control, synchronization and multi-purpose signals, page 38
- 2 = Power switch, power supply, monitor, LAN and USB connectors, page 40
- 3 = Digital IO DD connectors and instrument boards, page 41

5.2.1 Control, synchronization and multi-purpose connectors

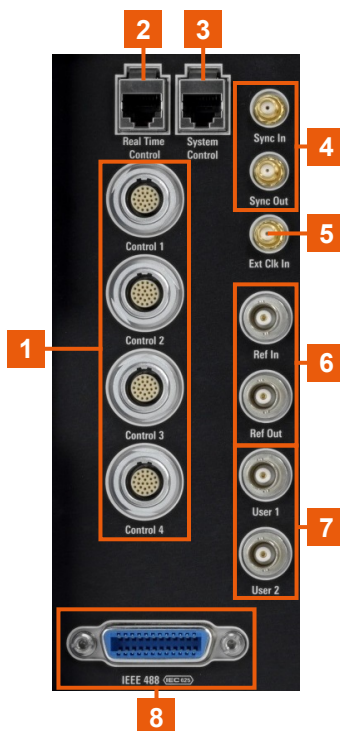

Figure 5-4: Connectors for control, synchronization and multi-purpose signals

- 1 = Control, page 38
- 2 = Real Time Control, page 38
- 3 = System Control, page 39
- 4 = Sync In, Sync Out, page 39
- 5 = Ext Clk In, page 39
- 6 = Ref In/Ref Out, page 39
- 7 = User x, page 39
- 8 = IEEE 488, page 39

Control

Four propriety bus connectors "Control 1" to "Control 4" for control of TRX frontends.

How to: [Chapter 4.14, "Connecting a TRX frontend"](#), on page 26

Real Time Control

RJ-45 connector to transfer real-time data in dynamic radar scenarios. Real-time data transfer is required for hardware in the loop (HiL) or vehicle in the loop (VIL) testing.

System Control

RJ-45 connector to control R&S QAT100 frontends.

How to: [Chapter 4.7, "Connecting to LAN"](#), on page 19

Sync In, Sync Out

SMA female connectors for synchronization of multi-device setups including more instruments.

How to: ["To connect to SMA connectors"](#) on page 23

Ext Clk In

SMA female connector for input of an external reference signal.

How to: ["To connect to SMA connectors"](#) on page 23

Ref In/Ref Out

Input/output for external reference signal.

BNC connectors for 10 MHz reference signals.

How to: [Chapter 4.11, "Connecting to Ref In/Ref Out"](#), on page 24

User x

BNC multipurpose connectors for defining output signals.

[Table 5-7](#) lists the signals assigned to the User x connectors in the default instrument state.

Table 5-7: Default configuration of the User x connectors

Connector	Direction	Default assigned signal
"User 1"/"User 2"	"Output"	"Object Marker"
	"Not used"	"None"

See also chapter "Global connectors settings" in the user manual.

IEEE 488

General purpose interface bus (GPIB) interface for remote control of the instrument. The interface is in compliance with the standards IEC 625, IEEE 488 and SCPI.

Use this interface to connect a computer for remote control of the R&S AREG800A. To set up the connection, use high-quality shielded cables. See ["Cable selection and electromagnetic interference \(EMI\)"](#) on page 17.

See also "Annex: Hardware interfaces" and chapter "Network and remote control" in the user manual.

5.2.2 Monitor, LAN, USB and power connectors

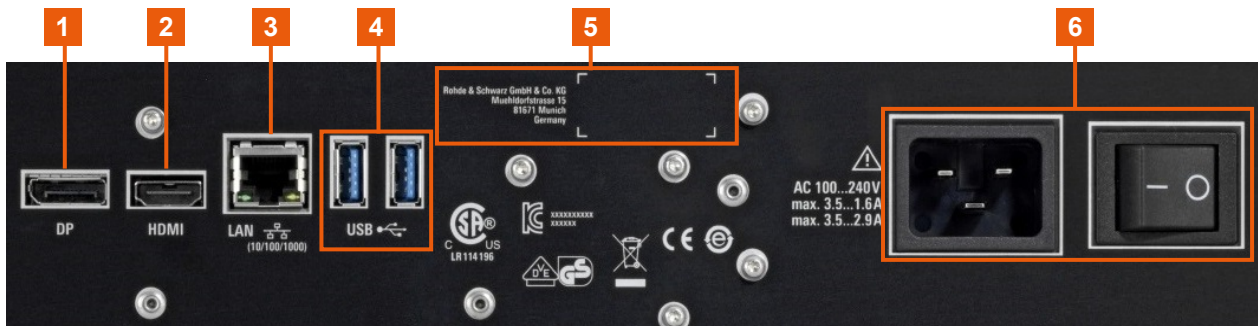

Figure 5-5: Power switch, power supply, monitor, LAN and USB connectors

- 1, 2 = DP, HDMI, page 40
- 3 = LAN, page 40
- 4 = USB, page 40
- 5 = Serial number
- 6 = AC power supply connector and switch, page 40

DP, HDMI

Display port (DP) and HDMI port for connecting external monitor.

LAN

RJ-45 connector to connect the R&S AREG800A to a LAN for remote control, remote operation, and data transfer.

How to: [Chapter 4.7, "Connecting to LAN"](#), on page 19

USB

Two female USB (universal serial bus) 3.0 connectors of type A. You can connect devices like a keyboard, a mouse, a memory stick or the R&S NRP-Z4 cable for the R&S NRP power sensors.

How to: [Chapter 4.8, "Connecting USB devices"](#), on page 20

AC power supply connector and switch

Mains power switch for performing the following tasks:

- Connecting the internal power supply to the power source
- Disconnecting the internal power supply from the power source

How to: [Chapter 4.6, "Connecting to power"](#), on page 19.

5.2.3 DIG I/Q and RF connectors



Figure 5-6: Digital IO DD connectors and instrument boards

- 1 = Digital IO DD, page 41
- 2, 10 = Aux IF In, page 41
- 3, 9 = Tx IF Out, page 42
- 4, 8 = Aux IF Out, page 41
- 5, 7 = Rx IF In, page 42
- 6 = Four instrument boards "A" to "D" (4x R&S AREG8-B9)

Digital IO DD

Digital I/Q connectors "Digital IO DD 1" to "Digital IO DD 4" provided for future use; one connector per instrument board (R&S AREG8-B9).

Aux IF In

SMA female connectors "Aux IF In 1" and "Aux IF In 2" for input of an additional interferer to the generated echo signal; two connectors per instrument board (R&S AREG8-B9).

How to: ["To connect to SMA connectors"](#) on page 23

Aux IF Out

SMA female connectors "Aux IF Out 1" and "Aux IF Out 2" for output of IF signals for signal analysis; two connectors per instrument board (R&S AREG8-B9).

How to: ["To connect to SMA connectors"](#) on page 23

Rx IF In

SMA female connectors "Rx IF In 1" and "Rx IF In 2" for input of the intermediate frequency (IF) signal from the external frontend to the R&S AREG800A (Rx); two connectors per instrument board (R&S AREG8-B9).

How to: ["To connect to SMA connectors"](#) on page 23

Tx IF Out

SMA female connectors "Tx IF Out 1" and "Tx IF Out 2" for output of the intermediate frequency (IF) signal from R&S AREG800A to the external frontend (Tx); two connectors per instrument board (R&S AREG8-B9).

How to: ["To connect to SMA connectors"](#) on page 23

6 Trying out the instrument

This chapter introduces the first steps with the R&S AREG800A. It shows how to operate and configure the instrument using simple examples. The complete description of the functionality and its usage is given in the R&S AREG800A user manual.

Prerequisites

- The R&S AREG800A is set up, connected to power, and started up. See [Chapter 4, "Preparing for use"](#), on page 14.
- The R&S AREG800A is connected to an external frontend, e.g. the R&S QAT100. See [Chapter 4.10, "Connecting the R&S QAT100"](#), on page 23.
- The R&S AREG800A is manually operated via the touchscreen.

Try out the following:

- [Configuring static operation setups](#)..... 43
- [Saving and recalling settings](#)..... 45

6.1 Configuring static operation setups

To specify characteristics of the radar object

1. In the tile diagram, select "Operation Setup".
2. Specify the radar object movement of the requirement:
 - Select "Mode > Static" for simulation of static radar objects.
 - Select "Mode > Dynamic" for simulation of dynamic radar objects.
3. Specify the reference of the radar object:
 - Select "Object Reference > Origin", if the R&S AREG800A is the object reference.
 - Select "Object Reference > Mapped Sensor", if a sensor is the object reference. This sensor is connected

- Click "Apply".

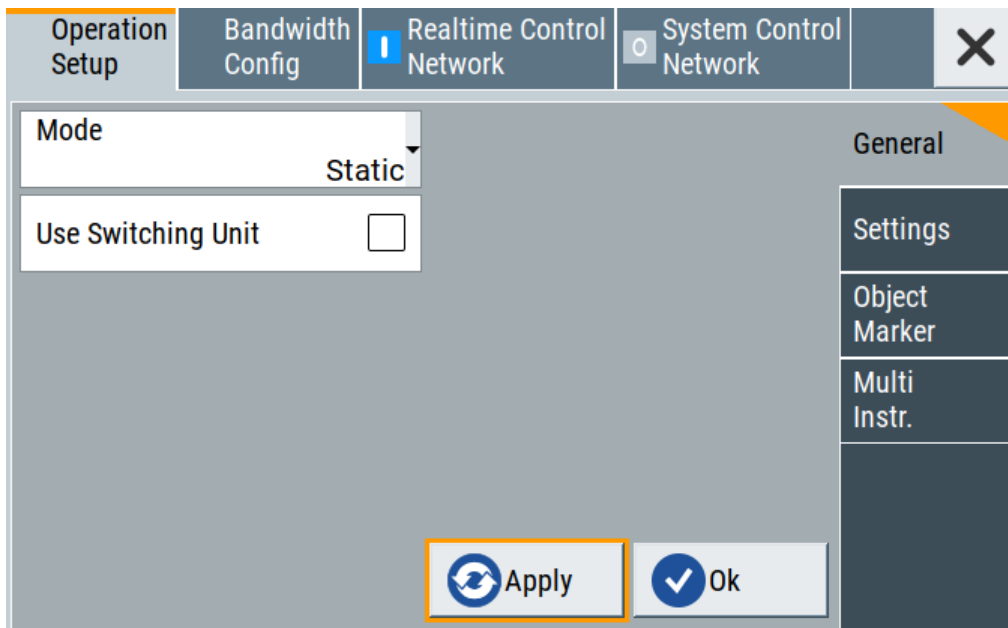

The settings are applied.

To specify the radar channel bandwidth

- In the tile diagram, select "Operation Setup > Bandwidth Config".
- Set the bandwidths of the radar channels, e.g. "Bandwidth A > 1 GHz".
- Click "Apply" and "Ok".

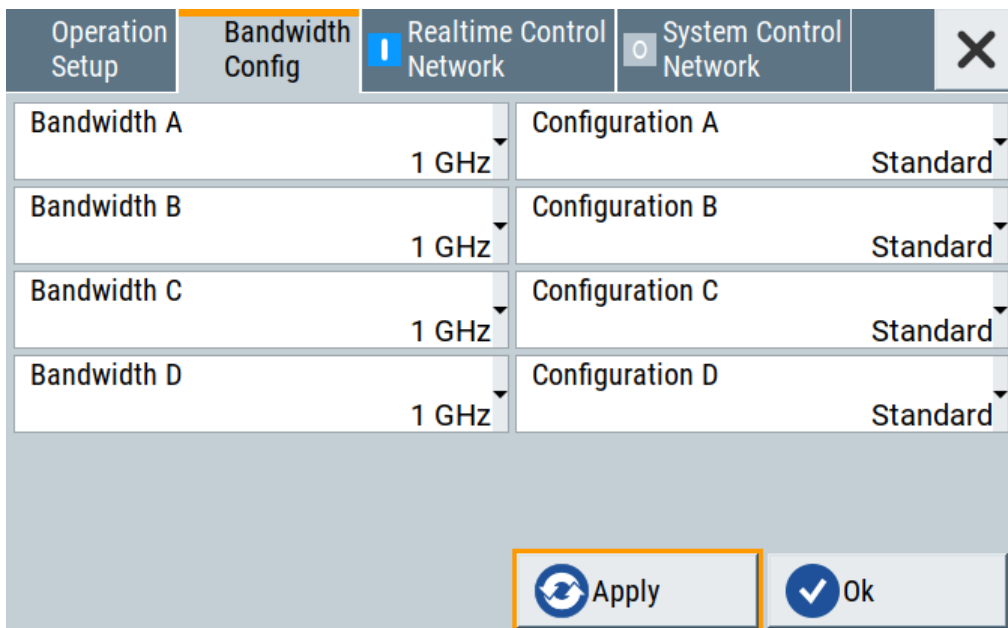

The bandwidth settings for an external frontend connected to board "A" are applied.

6.2 Saving and recalling settings

To restore the results of our measurements later, we save the instrument settings in a file.

To save the instrument settings in a file

We assume, a test configuration as described in [Chapter 6.1, "Configuring static operation setups"](#), on page 43.

1. Press the [Setup] key on the front panel.
2. In the "Setup" menu, select "Settings > Save/Recall".
3. In the "Save/Recall" dialog, select "Operation Mode > Save".

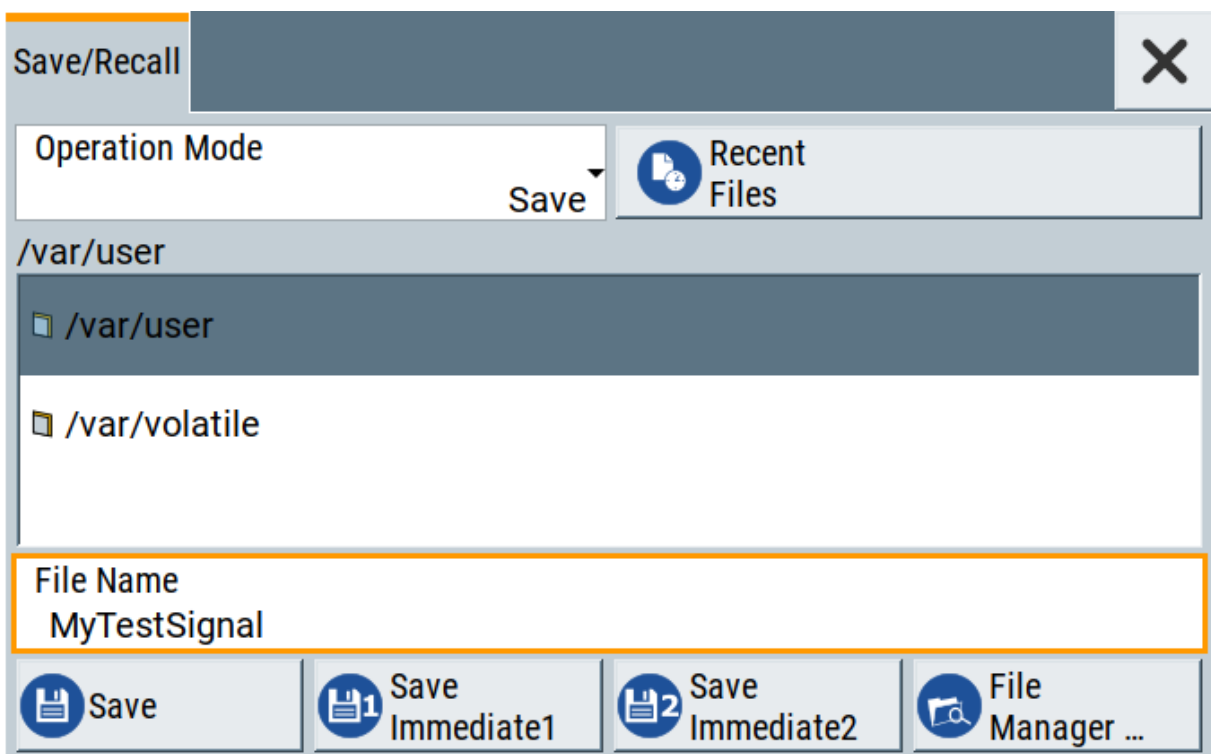

4. Select the "Filename" input field, use the on-screen keyboard, and enter *MyTestSignal*.

5. Click "Save".

The file `MyTestSignal.savrcltxt` is stored in the default directory `/var/user/`.

To load saved instrument settings

You can restore the settings to the instrument at any time using the settings file.

1. Press the [Preset] button to restore the default instrument settings so you can check that the stored user settings are restored afterwards.
2. Press the [Setup] key on the front panel.
3. In the "Setup" menu, select "Settings > Save/Recall".
4. In the "Save/Recall" dialog, select "Operation Mode > Recall".
Navigate to the directory the file is saved in and select the `MyTestSignal` file.

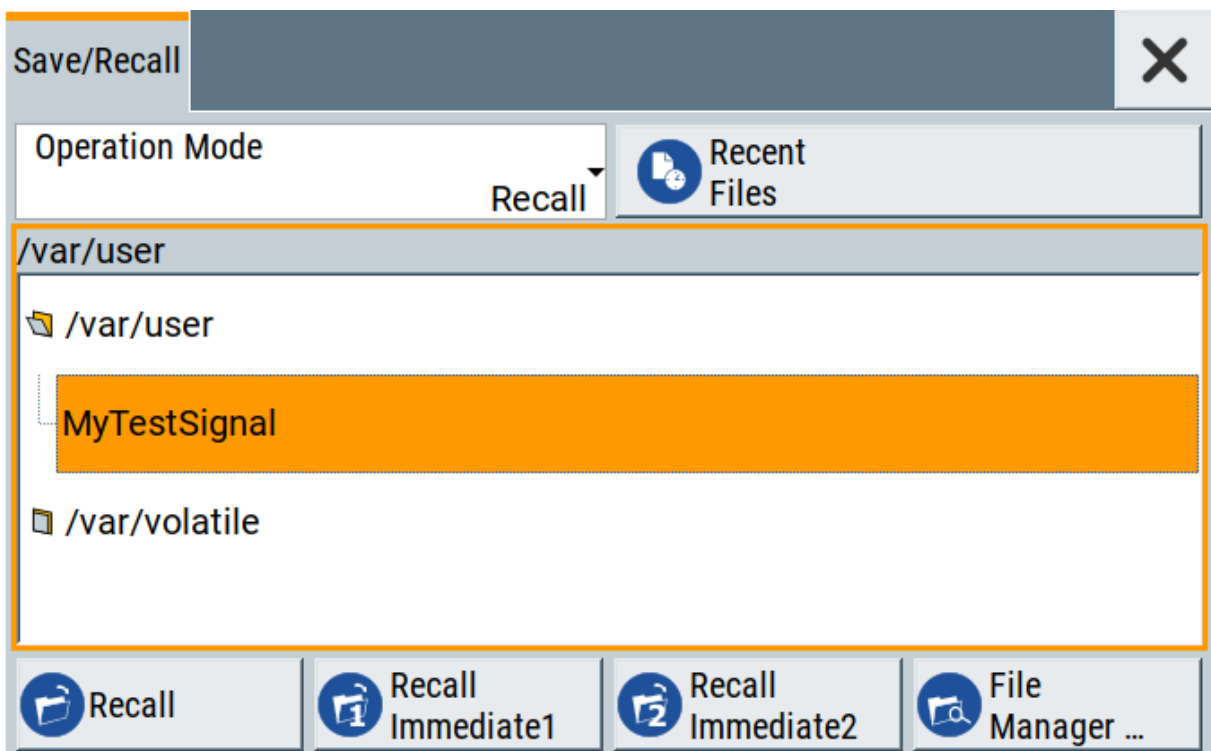

5. Click "Recall".

All instrument settings are restored and the display resembles [Chapter 6.1, "Configuring static operation setups"](#), on page 43, which shows the instrument display right before the settings were saved.



How to display all parameters with values different to their preset values

When you load a file to your instrument, you do not have enough information on the changed settings. In such case, it is useful to visualize all parameters that have been changed from their default state.

Try out the following:

- Touch and hold a spot in the tile diagram for at least 1 second to access the context-sensitive menu.
- Select "Mark All Parameters Changed from Preset".

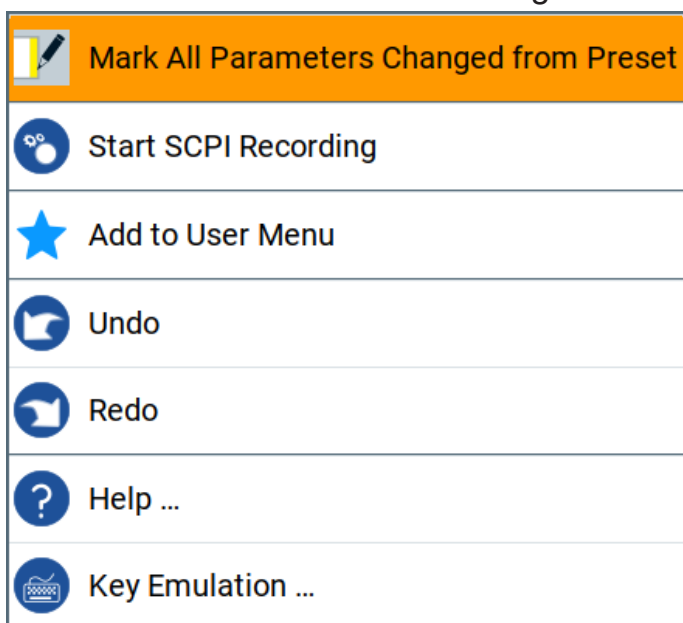

- All changed parameters are highlighted.

7 Instrument control

This chapter provides an overview on how to work with the R&S AREG800A.

It covers the following topics:

• Possible ways to operate the instrument	48
• Means of manual interaction	49
• Understanding the display information	49
• Accessing the functionality	54
• Entering data	55
• Getting information and help	57
• Remote control	58
• Remote operation over VNC	59
• Remote operation over web UI	60

7.1 Possible ways to operate the instrument

There are three ways to operate the R&S AREG800A:

- **Manual operation:**
Use the touchscreen, hard keys and rotary knob, or an optional mouse and/or keyboard.
- **Remote control:**
Create programs to automatize repeating settings, tests and measurements. The instrument is connected to a computer running the program. This way of operation is described in the user manual, chapter "Network and Remote Control Operation".
- **Remote operation from a computer:**
Remote monitoring and control of the instrument from a connected computer is based on the common cross-platform technology VNC (Virtual Network Computing). On the remote computer, any standard web browser (supporting Java) or a dedicated VNC client (like Ultr@VNC) can be used. See also [Chapter 7.8, "Remote operation over VNC"](#), on page 59.

The following sections show how to operate the instrument manually.

7.2 Means of manual interaction

For the manual interaction with the R&S AREG800A, you have several methods that you can use as an alternative to perform a task:

- **Touchscreen:**
Touchscreen operation is the most direct way to interact. Almost all control elements and actions on the screen are based on the standard operating system concept. You can tap any user interface element to set parameters in dialog boxes, enter data, scroll within a dialog etc., as if you work with a mouse pointer.
Tapping the screen works like clicking mouse buttons:
 - Touch quickly = click: Selects a parameter or provokes an action.
 - Touch and hold = right-click: Opens a context-sensitive menu.
 - Touch and swipe = drag: Scrolls through the contents of a display element larger than the screen, e.g. a list or a table.
- **Function keys and rotary knob:**
The front panel provides nearly all functions and controls to operate the instrument in the classic way, without touchscreen.
- **Optional mouse and/or keyboard:**
These devices work like known from PCs. The navigation keys on the front panel correspond to the keys on the keyboard.

This manual describes the manual interaction with the instrument via the touchscreen. It mentions the alternative methods using the keys on the instrument or the on-screen keypads if it deviates from the standard operating procedures. The usage of the touchscreen and navigation keys is described in [Chapter 7.4, "Accessing the functionality"](#), on page 54.

Throughout the manual, the term "select" refers to any of the following methods:

- Using a finger on the touchscreen
- Using a mouse pointer in the display
- Using a key on the instrument or on a keyboard

7.3 Understanding the display information

The home screen of the R&S AREG800A displays all main settings and generator states, divided into main operation areas.

Understanding the display information

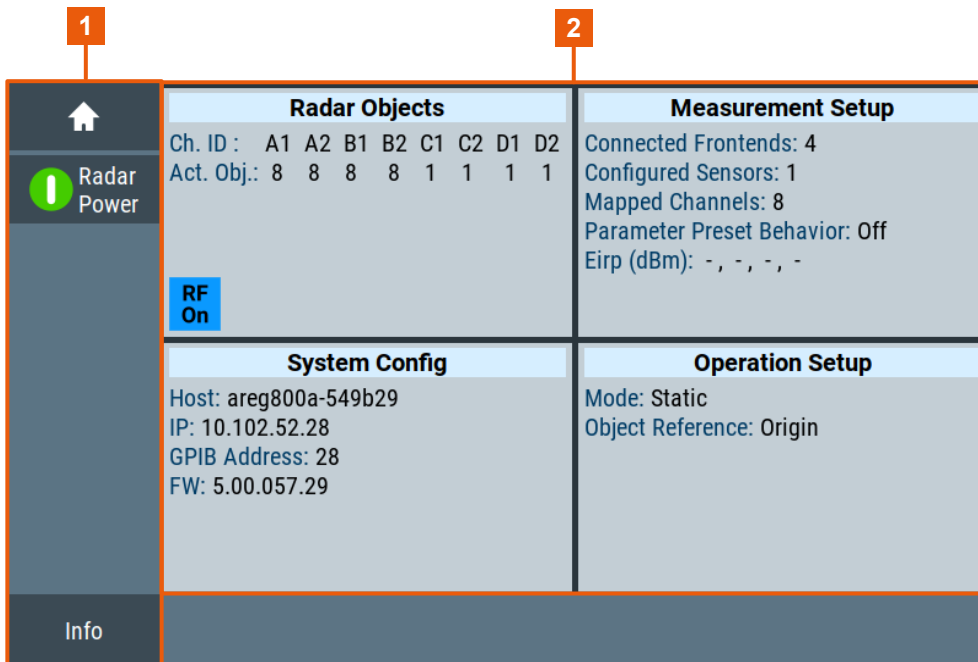

Figure 7-1: Home screen

1 = Taskbar/softkey bar with "Home" and "Info" key
 2 = Tile diagram



- [Taskbar](#).....50
- [Tile diagram](#).....51
- [Additional display characteristics](#)..... 52

7.3.1 Taskbar

The "Taskbar" shows a home and an info button, and assigns a labeled button whenever you open a dialog. If more dialogs are open than the taskbar can display, touch and swipe the taskbar to scroll up and down.

The buttons shown in the following example represent the variants.

Table 7-1: Example of buttons in the taskbar

	"Home" button Returns to the home screen.
	"Busy" indicator Indicates a running process.

Understanding the display information

	<p>"User Menu" Lists parameters that can be defined for quick access.</p>
	<p>Shows the current remote access connections when the instrument is remotely controlled. Tip: An indicator in the "System Config" tile shows the current remote control status.</p>
	<p>R&S NRP power sensors Shows a connected external power sensor. The button displays the current readings when the sensor is active.</p>
	<p>Active dialogs Indicates the dialog name of each active dialog in a separate button.</p>
	<p>"Info" key Provides access to status and error messages. Note: The warning symbol signifies a permanent error message.</p>

7.3.2 Tile diagram

The tile diagram is the main entry to the settings of the R&S AREG800A.

Tile	Access to:
"Radar Objects"	<ul style="list-style-type: none"> • RF ON • Configuration • Units • Radar Power • Overview • Graphics
"Measurement Setup"	<ul style="list-style-type: none"> • Preset Behavior On • Configuration • Channel Mapping • Units • Overview • Reference Frequency • Power Sensors <ul style="list-style-type: none"> – NRP Power Viewer – NRP Sensor Mapping

Tile	Access to:
"System Config"	<ul style="list-style-type: none"> • Setup • Info/Notifications • Remote Access • Save/Recall
"Operation Setup"	Opens the operation setup dialog with tabs <ul style="list-style-type: none"> • Operation Setup • Bandwidth Config • Realtime Control Network • System Control Network

7.3.3 Additional display characteristics

The following section provides a short insight on the indication of the screen in general, and significant elements that you see under specific operating modes, in dialogs or settings.

- **Appearance of active elements**

- *Active* elements like On/Off switches, state buttons have a **blue** background.
- *Selected* elements are framed or highlighted **orange**.
- *Inactive* elements are **gray**.

- **On-Screen keypads**

As additional means of interacting with the instrument without having to connect an external keyboard, either a numerical or alphanumerical on-screen keypad appears when you activate an entry field (see [Chapter 7.5, "Entering data"](#), on page 55).

- **Info line**

The "Info line" shows brief status information and error messages. It appears when an event generates a message. If selected, the R&S AREG800A shows information on static errors and the error history.

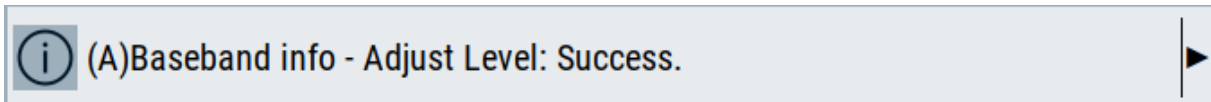

- **Key parameters indicated in tab labels**

Most dialogs are divided into tabs with logically grouped parameters. The tab label expresses the content and can also contain status indicators.

Understanding the display information

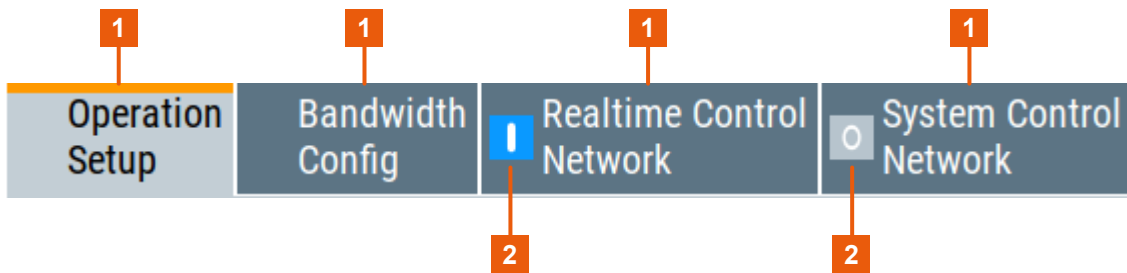

1 = Tab label

2 = Status indicators

- **Scrollbar handle**

An arrow icon that appears when you touch a scrollbar helps you to scroll in a dialog or list.

- **Progress indicators**

A busy icon indicates a currently running process. If a process takes some time, a progress bar shows the current state.

- **Context-sensitive menus**

Within the entire screen display, including single parameters, you can access context-sensitive menus that provide some additional functions.

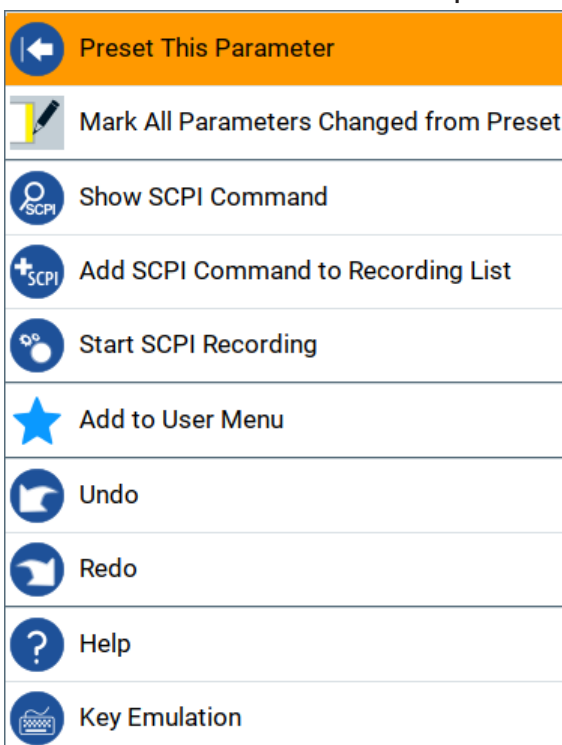

7.4 Accessing the functionality

All functionalities are provided in dialog boxes as known from computer programs. You can control the instrument intuitively with the touchscreen. This section provides an overview of the accessing methods.

The instrument's functions and settings can be accessed by selecting one of the following elements:

- System and function keys on the front panel of the instrument
- Taskbar/softkeys on the touchscreen
- Context-sensitive menus for specific elements on the touchscreen, or with the rotary knob (press and hold).
- Elements on the status bar in the touchscreen
- Displayed setting on the touchscreen that means block diagram and all settings available in dialogs.

To open a dialog box

- ▶ Perform one of the following actions:
 - Tap the required tile, and then the menu entry.
 - Tap the minimized view (button) on the taskbar.

Some of the utility keys access a dedicated dialog, too.

To minimize a dialog box

- ▶ To return to the home screen, tap the "Home" button.

To close a dialog box

To close a dialog box, you have the same controls as you know from computers or devices with touchscreen.

- ▶ Perform one of the following actions:
 - Tap the "Close" icon in the upper right corner.
 - Press the [Esc] key on the front panel.
 - Drag and drop a minimized dialog from the taskbar to the tile diagram.

To select an option in a dialog box

- ▶ Tap the required option.

7.5 Entering data

Some parameters have their own key on the front panel.

For data input in dialog boxes, the instrument provides on-screen keypads for entering numeric and alphanumeric values. Thus, you can always set the parameters via the touchscreen, the front panel, or an external keyboard.

To correct an entry

1. Using the arrow keys, move the cursor to the right of the entry you want to delete.
2. Press the [Backspace] key.
3. Deletes the entry to the left of the cursor.
4. Enter your correction.

To complete the entry

- ▶ Press the [Enter] key or the rotary knob.

To abort the entry

- ▶ Press the [Esc] key.
The dialog box closes without changing the settings.

7.5.1 Entering numeric parameters

To enter values with the on-screen keypad

For numeric settings, the instrument displays the numeric keypad. The units specified correspond to the units of the parameter.

1. Enter the numeric value.
Tip: For quick entry, you can enter a value in exponential representation, e.g. $1e7$ for 10000000 .
2. Tap the unit button to complete the entry.
The unit is added to the entry.

Tip: For quick unit change, you can enter shortcuts, e.g. for a frequency value *1e8h* for *100 MHz*.

For an overview of shortcuts supported by the R&S AREG800A, see chapter "Unit Shortcuts" in the appendix of the user manual.

3. If the parameter does not require a unit, confirm the entered value by pressing "Enter".

To enter values by using the front panel controls

1. Change the currently used parameter value by using the rotary knob or the [Up/Down] keys.
2. If the parameter does not require a unit, confirm the entered value by pressing the [Enter] key or any of the unit keys.
The instrument highlights the editing line to confirm the entry.

If you edit numeric data in tables, the entry field must be in edit mode: Press [Enter], or the rotary knob to activate the edit mode.

7.5.2 Entering alphanumeric parameters

If a field requires alphanumeric input, you can use the on-screen keyboard to enter letters and (special) characters.

7.5.3 Undo and redo actions

Accessed via the context-sensitive menus, "Undo" allows you to restore one or more actions on the instrument. Depending on the available memory, the "Undo" steps can restore all actions.

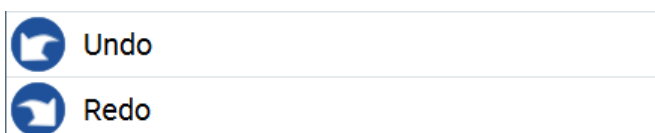

"Redo" restores a previously undone action.

7.6 Getting information and help

In some dialog boxes, graphics are included to explain the way a setting works.

For further information, you can use the following sources:

- Tooltips give the value range of the parameter.
- The context help provides functional description on a setting.
- The general help explains a dialog box, provides instructions, and general information.

To display context help

- ▶ To access a help topic, perform one of the following:
 - a) Tap and hold the parameter for which you need information and tap "Help" in the context menu.
 - b) Tap the parameter and press the [Help] key.

The "Help" dialog opens. You can browse the help for further information.

Help

Configuring radar obj...
Radar Objects tile
Objects settings
Channel x
Object table

Configuring radar objects > Objects settings > Object table

Object table

Each radar channel can simulate up to eight radar objects. Configuration is provided in a table, where the rows constitute the individual radar object and the columns constitute radar object characteristics. For each radar object, you can configure simulation state, range, attenuation, Doppler speed, horizontal angle and radar cross section (RCS).

Object	State	Range /m	Attenuation /dB	Doppler Speed /(km/h)	Horizontal Angle /deg	RCS /dBm ²
1	On	20.00	50.0	0.0	0.0	0.0
2	On	20.00	50.0	0.0	0.0	0.0

Contents Index Find Hide Contents Tree Back Zoom In Zoom Out

Contents of the help dialog box

The help dialog box covers two main areas:

- "Contents" - contains a table of help contents
- "Topic" - contains a specific help topic

The help system also provides an "Index" and a "Find" area, and "Zoom" functions that are accessed via the corresponding buttons.

To open general help

- ▶ Press the yellow [Help] key on the front panel.
If a dialog box is opened, the help topic for the current tab is shown. Otherwise the "Contents" page appears.

Navigating in the table of contents and in the help topics

1. To move through the displayed contents entries, tap on an entry and scroll or use a connected mouse or the [Up/Down] keys.
Entries with a plus sign contain further entries.
2. To display a help topic, tap on the topic name or double-click the topic name or press the [Enter] key.
3. To follow a cross-reference, tap on the link text.
4. To return to the previous page, select "Back".
This function scrolls back all steps you have performed before.
5. Use the "scroll bars" to shift the visible section of content shown.
6. To maximize the "Topics" area, tap the "Hide Contents Tree" button to hide the contents tree.

Using the index

1. Select the "Index" button.
2. Enter the first characters of the topic you are interested in.
The entries starting with these characters are displayed.
3. Tap on the index entry.
The corresponding help topic is displayed.

7.7 Remote control

In addition to working with the R&S AREG800A interactively, located directly at the instrument, it is also possible to operate and control it from a remote PC.

The R&S AREG800A supports various methods for remote control:

- Connecting the instrument to a LAN (see [Chapter 4.7, "Connecting to LAN"](#), on page 19)
- Using the LXI browser interface in a LAN
- Connecting a PC via the IEC-bus (IEEE 488) interface
- Remote control via the USB interface



For remote control over LAN or USB, you can use the R&S VISA (Virtual Instrument Software Architecture) library provided for download at the Rohde & Schwarz website <http://www.rohde-schwarz.com/rsvisa>.

How to configure the remote control interfaces is described in the user manual, chapter "Network and remote control operation".

7.8 Remote operation over VNC

The VNC is an application which can be used to access and control the instrument from a remote computer through a LAN connection. While the instrument is in operation, the instrument screen contents are displayed on the remote computer, and VNC provides access to all applications, files, and network resources of the instrument. Thus, remote operation of the instrument is possible.



Instrument control from a remote computer

To access the basic utility functions of the R&S AREG800A, perform a right mouse click the block diagram and select "Key Emulation".

A key panel to the right of the block diagram gives access to the utility functions provided by the front panel keys.

The VNC is an add-on program, included in operating system Linux/Unix, and available as a free-of-charge download on the internet.

See also the R&S AREG800A user manual, chapter "To operate the instrument using VNC".

7.9 Remote operation over web UI

You can configure the R&S AREG800A, for example in a multi instrument test setup, over web user interface (web UI). All instruments must be connected to the same LAN.

See also the R&S AREG800A user manual, chapter "Test setup for multiple instruments".

Access:

- In the address field of the browser, enter `<ipaddress>/webui`.

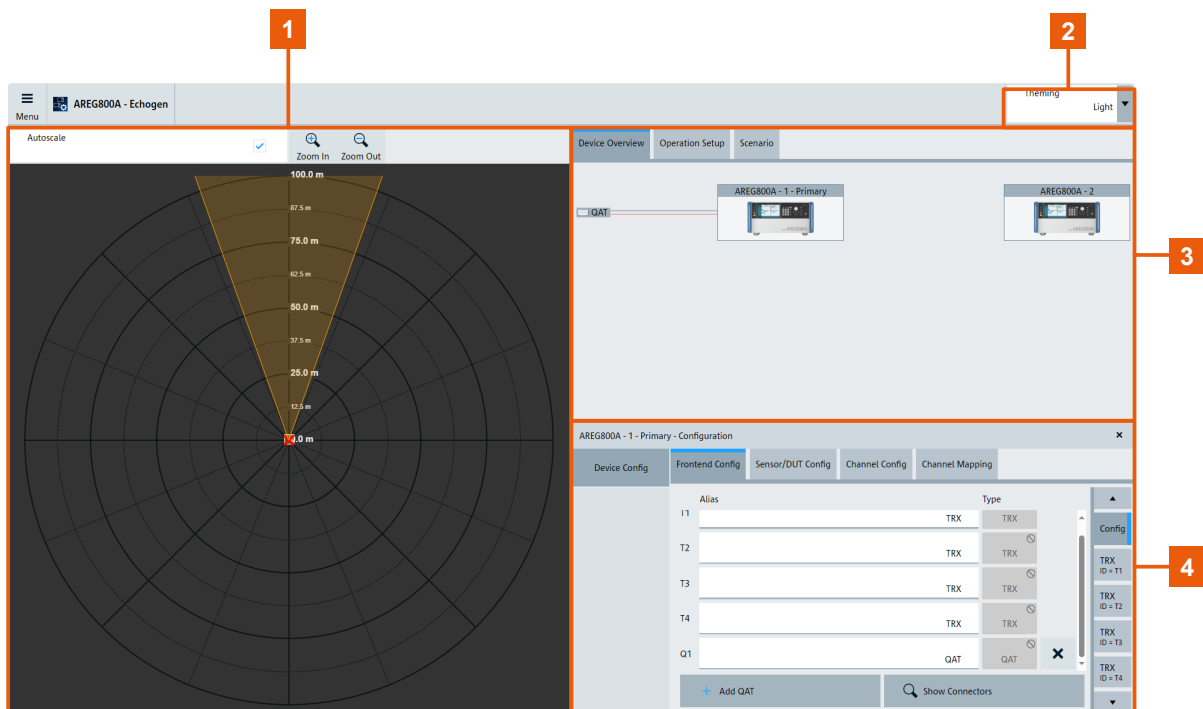

- 1 = Overview area
- 2 = Theming
- 3 = Setup area
- 4 = Configuration area

The web UI allows you to define your operation setup and configure the connected instruments.

Settings:

Overview area.....	61
Theming.....	61
Setup area.....	61
Configuration area.....	61

Overview area

Displays an overview of all objects within the radar object simulation scenario.

Theming

Selects the theming of the web UI interface. You can select light or dark theming.

Setup area

In this area, you can define your operation setup.

"Device Overview"

Displays the instruments in the test setup. Click on the instrument to select the respective R&S AREG800A for configuration in the configuration area.

"Operation Setup"

Define the operation setup settings for all connected instruments.

"Scenario"

Requires "Operation Setup > Mode > Dynamic".
Select a scenario file stored on your instrument and play the scenario.

Configuration area

You can configure the selected R&S AREG800A.

8 Contacting customer support

Technical support – where and when you need it

For quick, expert help with any Rohde & Schwarz product, contact our customer support center. A team of highly qualified engineers provides support and works with you to find a solution to your query on any aspect of the operation, programming or applications of Rohde & Schwarz products.

Contact information

Contact our customer support center at www.rohde-schwarz.com/support, or follow this QR code:



Figure 8-1: QR code to the Rohde & Schwarz support page

Index

- A**
- Active elements 52
 - Alphanumeric parameters 56
- B**
- Bench top, placing 15
- C**
- Carrying the instrument 14
 - Checking the instrument 14
 - Connecting
 - Keyboard 20
 - LAN 19
 - Memory stick 20
 - Mouse 20
 - Power 19
 - To Digital IO DD 25
 - To Ref In/Ref Out 24
 - To RF coaxial connectors 21
 - USB devices 20
 - Connecting to RF coaxial connectors
 - To connect to pluggable connectors ... 22
 - To connect to screwable connectors ... 22
 - To prepare for connecting 21
 - Connector
 - AC power supply 40
 - GPIB 39
 - IEC/IEEE 39
 - LAN 40
 - Ref In 39
 - Ref Out 39
 - USER 39
 - Context-sensitive menu 52
 - Customer support 62
- D**
- Data entry 55
 - Data sheets 12
 - Dialog boxes 54
 - Display
 - Active elements 52
 - Context-sensitive menu 52
 - Info line 52
 - Information 49
 - On-screen keypad 52
 - Tab labels 52
 - Taskbar 50
 - Tile diagram 51
- E**
- Emulating front panel keys 59
- G**
- Getting started 11
- H**
- Help 11, 57
- I**
- Info line 52
 - Input connector 39
 - Instrument
 - Carrying 14
 - Checking 14
 - Lifting 14
 - Operating site 15
 - Unpacking 14
 - Instrument control 48
- K**
- Key
 - Access on a remote computer 59
 - Arrow 35
 - Backspace 34
 - Down 35
 - Emulation 59
 - Enter 34
 - Esc 34
 - Freq 33
 - Help 32
 - Home 35
 - Left 35
 - Level 33
 - Local 32
 - Mod On/Off 33
 - Next window 35
 - On/Off 35
 - On/Standby 32
 - Preset 32
 - RF On/Off 33
 - Right 35
 - Setup 32
 - Undo 35

- Up 35
- User 35
- Key features 13
- Keyboard
 - On-screen 55
 - Usage 49
- Keypad
 - On-screen 55
- L**
- LAN
 - Connecting 19
 - Environment 19
- Lifting the instrument 14
- Loading
 - Trying out 46
- M**
- Manual interaction 49
- Mounting, in a rack 16
- Mouse
 - Usage 49
- N**
- Navigation
 - Keys 35
- Network
 - Environment 19
- Numeric data entry 55
- Numeric parameters 55
- O**
- On-screen keyboard 56
- On-screen keypad 52
- Open source acknowledgment (OSA) 12
- Operating site
 - Choosing 15
 - Setting up the instrument 15
- Operation
 - Manual 49
- Output connector 39
- P**
- Parameters
 - Entering 55, 56
- Placing, on a bench top 15
- Power
 - Connecting the instrument 19
- Power on
 - Key 32
- Power supply
 - Connector 40
- Preparing for use 14
 - Connecting R&S QAT100 23
- R**
- Rack, mounting 16
- Release notes 12
- Remote access
 - see Remote operation from a computer
 - 48
- Remote control 58
- Remote operation 59
- Rotary knob 34
- S**
- Safety instructions 5, 11
- Softkey bar
 - See Taskbar 50
- Standby
 - Key 32
- Switching
 - On or off 28
- T**
- Tab labels 52
- Text entry 55
- Tile diagram
 - Display 51
- Tooltips
 - Show 57
- Touchscreen
 - Compared with mouse 49
 - Overview 31
 - Usage 49
- U**
- Unpacking the instrument 14
- User manual 11
- Utility keys
 - Overview 32
- V**
- VNC
 - Using in a LAN 59