

R&S®FPS-K40

Phase Noise Measurements User Manual



1176850002
Version 03



This manual applies to the following R&S®FPS models with firmware version 1.70 and higher:

- R&S®FPS4 (1319.2008K04)
- R&S®FPS7 (1319.2008K07)
- R&S®FPS13 (1319.2008K13)
- R&S®FPS30 (1319.2008K30)
- R&S®FPS40 (1319.2008K40)

The following firmware options are described:

- R&S FPS-K40 (1321.4110.02)

© 2021 Rohde & Schwarz GmbH & Co. KG

Mühlhofstr. 15, 81671 München, Germany

Phone: +49 89 41 29 - 0

Email: info@rohde-schwarz.com

Internet: www.rohde-schwarz.com

Subject to change – data without tolerance limits is not binding.

R&S® is a registered trademark of Rohde & Schwarz GmbH & Co. KG.

Trade names are trademarks of the owners.

1176.8500.02 | Version 03 | R&S®FPS-K40

The following abbreviations are used throughout this manual: R&S®FPS is abbreviated as R&S FPS.

Contents

1	Preface	5
1.1	Typographical Conventions.....	5
2	Welcome to the Phase Noise Measurement Application	6
2.1	Starting the Application.....	6
2.2	Understanding the Display Information.....	7
3	Measurements and Result Displays	11
4	Measurement Basics	19
4.1	Spurs and Spur Removal.....	19
4.2	Residual Effects.....	20
4.3	Measurement Range.....	21
4.4	Sweep Modes.....	22
4.5	Trace Averaging.....	22
4.6	Frequency Determination.....	24
4.7	Level Determination.....	27
4.8	Signal Attenuation.....	27
4.9	Using Limit Lines.....	28
4.10	Analyzing Several Traces - Trace Mode.....	30
4.11	Using Markers.....	32
5	Configuration	33
5.1	Configuration Overview.....	33
5.2	Default Settings for Phase Noise Measurements.....	35
5.3	Configuring the Frontend.....	35
5.4	Controlling the Measurement.....	37
5.5	Configuring the Measurement Range.....	40
5.6	Performing Measurements.....	43
5.7	Configuring In- and Outputs.....	45
5.8	Automatic Measurement Configuration.....	45
6	Analysis	47
6.1	Configuring Graphical Result Displays.....	47
6.2	Configure Numerical Result Displays.....	54

6.3	Using Limit Lines.....	56
6.4	Using Markers.....	63
7	How to Configure Phase Noise Measurements.....	66
7.1	Performing a Basic Phase Noise Measurement.....	66
7.2	Customizing the Measurement Range.....	66
8	Remote Control Commands for Phase Noise Measurements.....	68
8.1	Common Suffixes.....	68
8.2	Introduction.....	69
8.3	Controlling the Phase Noise Measurement Channel.....	74
8.4	Performing Measurements.....	77
8.5	Configuring the Result Display.....	82
8.6	Configuring the Frontend.....	89
8.7	Controlling the Measurement.....	91
8.8	Configuring the Measurement Range.....	94
8.9	Using Limit Lines.....	100
8.10	Graphical Display of Phase Noise Results.....	111
8.11	Configure Numerical Result Displays.....	123
8.12	Using Markers.....	137
8.13	Configuring In- and Outputs.....	143
8.14	Automatic Measurement Configuration.....	145
8.15	Using the Status Register.....	146
8.16	Remote Control Example Scripts.....	152
	List of Remote Commands (Phase Noise).....	158
	Index.....	163

1 Preface

1.1 Typographical Conventions

The following text markers are used throughout this documentation:

Convention	Description
"Graphical user interface elements"	All names of graphical user interface elements on the screen, such as dialog boxes, menus, options, buttons, and softkeys are enclosed by quotation marks.
[Keys]	Key and knob names are enclosed by square brackets.
Filenames, commands, program code	Filenames, commands, coding samples and screen output are distinguished by their font.
<i>Input</i>	Input to be entered by the user is displayed in italics.
Links	Links that you can click are displayed in blue font.
"References"	References to other parts of the documentation are enclosed by quotation marks.

2 Welcome to the Phase Noise Measurement Application

The R&S FPS-K40 is a firmware application that adds functionality to measure the phase noise characteristics of a device under test with the R&S FPS signal analyzer.

This user manual contains a description of the functionality that the application provides, including remote control operation.

Functions that are not discussed in this manual are the same as in the Spectrum application and are described in the R&S FPS User Manual. The latest versions of the manuals are available for download at the product homepage.

<http://www.rohde-schwarz.com/product/FPS.html>.

Installation

Find detailed installing instructions in the Getting Started or the release notes of the R&S FPS.

- [Starting the Application](#)..... 6
- [Understanding the Display Information](#)..... 7

2.1 Starting the Application

The phase noise measurement application adds a new type of measurement to the R&S FPS.



Manual operation via an external monitor and mouse

Although the R&S FPS does not have a built-in display, it is possible to operate it interactively in manual mode using a graphical user interface with an external monitor and a mouse connected.

It is recommended that you use the manual mode initially to get familiar with the instrument and its functions before using it in pure remote mode. Thus, this document describes in detail how to operate the instrument manually using an external monitor and mouse. The remote commands are described in the second part of the document. For details on manual operation see the R&S FPS Getting Started manual.

To activate the Phase Noise application

1. Select the [MODE] key.
A dialog box opens that contains all operating modes and applications currently available on your R&S FPS.
2. Select the "Phase Noise" item.



The R&S FPS opens a new measurement channel for the Phase Noise application. All settings specific to phase noise measurements are in their default state.

Multiple Measurement Channels and Sequencer Function

When you enter an application, a new measurement channel is created which determines the measurement settings for that application. The same application can be activated with different measurement settings by creating several channels for the same application.

The number of channels that can be configured at the same time depends on the available memory on the instrument.

Only one measurement can be performed at any time, namely the one in the currently active channel. However, in order to perform the configured measurements consecutively, a Sequencer function is provided.

If activated, the measurements configured in the currently active channels are performed one after the other in the order of the tabs. The currently active measurement is indicated by a  symbol in the tab label. The result displays of the individual channels are updated in the tabs (as well as the "MultiView") as the measurements are performed. Sequential operation itself is independent of the currently *displayed* tab.

For details on the Sequencer function see the R&S FPS User Manual.

2.2 Understanding the Display Information

The following figure shows the display as it looks for phase noise measurements. All different information areas are labeled. They are explained in more detail in the following sections.

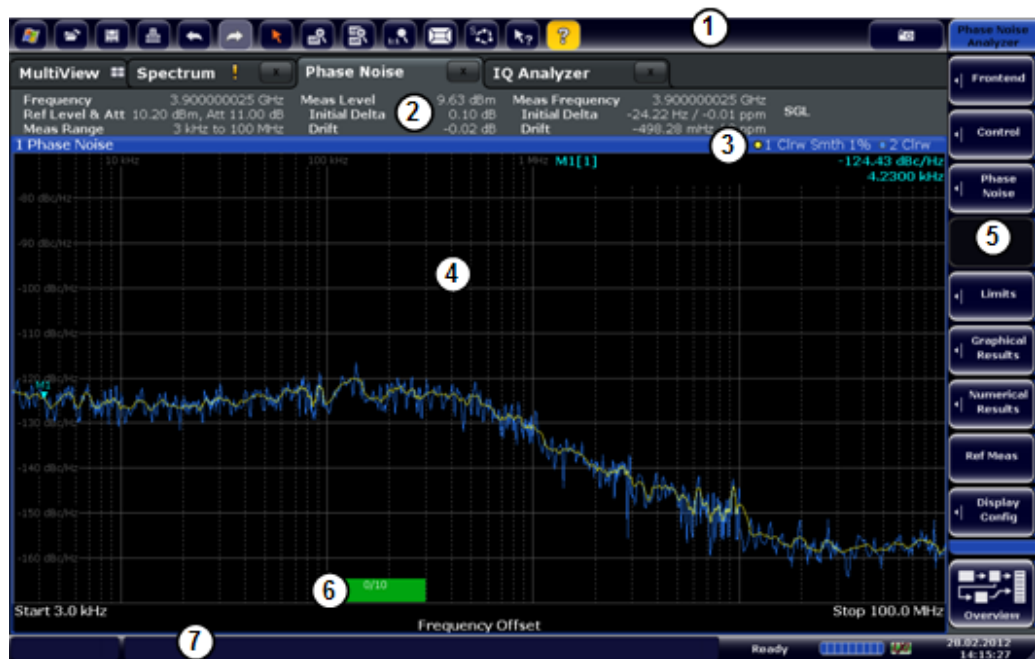

Figure 2-1: Screen layout of the phase noise measurement application

- 2 = Channel bar
- 3 = Diagram header
- 4 = Result display
- 5 = Softkey bar
- 6 = Measurement status
- 7 = Status bar

For a description of the elements not described below, please refer to the Getting Started of the R&S FPS.

Measurement status

The application shows the progress of the measurement in a series of green bars at the bottom of the diagram area. For each half decade in the measurement, the application adds a bar that spans the frequency range of the corresponding half decade.

The bar has several features.

- The numbers within the green bar show the progress of the measurement(s) in the half decade the application currently works on.
The first number is the current, the second number the total count of measurements for that half decade. The last number is the time the measurement requires.
- A double-click on the bar opens an input field to define the number of averages for that half decade.
- A right-click on the bar opens a context menu.

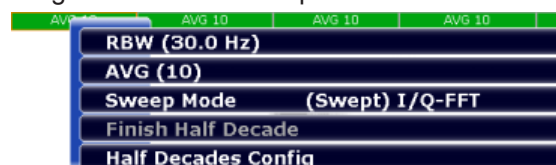

The context menu provides easy access to various parameters (resolution bandwidth, sweep mode etc.) that define the measurement characteristics for a half decade. The values in parentheses are the currently selected values. For more information on the available parameters see "[Half Decades Configuration Table](#)" on page 43.

Channel bar information

The channel bar contains information about the current measurement setup, progress and results.

Phase Noise					
Frequency	3.900000025 GHz	Meas Level	9.63 dBm	Meas Frequency	3.900000025 GHz
Ref Level & Att	10.20 dBm, Att 11.00 dB	Initial Delta	0.10 dB	Initial Delta	-24.22 Hz / -0.01 ppm
Meas Range	3 kHz to 100 MHz	Drift	-0.02 dB	Drift	-498.28 mHz / 0 ppm
					SGL

Figure 2-2: Channel bar of the phase noise application

Frequency	Frequency the R&S FPS has been tuned to. The frontend frequency is the expected frequency of the carrier. When frequency tracking or verification is on, the application might adjust the frontend frequency.
Ref Level & Att	Reference level (first value) and attenuation (second value) of the R&S FPS. When level tracking or verification is on, the application might adjust the frontend level.
Measurement	Complete phase noise measurement range. For more information see Chapter 4.3, "Measurement Range" , on page 21.
Measured Level	DUT level that has been actually measured. The measured level might differ from the frontend level, e.g. if you are using level verification.
Initial Delta	Difference between the nominal level and the first level that has been measured.
Drift	Difference between the 1st level that has been measured and the level that has been measured last. In continuous sweep mode, the drift is the difference between the 1st level that has been measured in the 1st sweep and the level that has been measured last.
Measured Frequency	DUT frequency that has been actually measured. The measured frequency might differ from the frontend frequency, e.g. if you are using level verification.
Initial Delta	Difference between the nominal frequency and the first frequency that has been measured.
Drift	Difference between the 1st frequency that has been measured and the frequency that has been measured last. In continuous sweep mode, the drift is the difference between the 1st frequency that has been measured in the 1st sweep and the frequency that has been measured last.
SGL [##/##]	Sweep mode (single or continuous). If you use trace averaging, it also shows the current measurement number out of the total number of measurements.

The following two figures show the relations between the frequency and level errors.

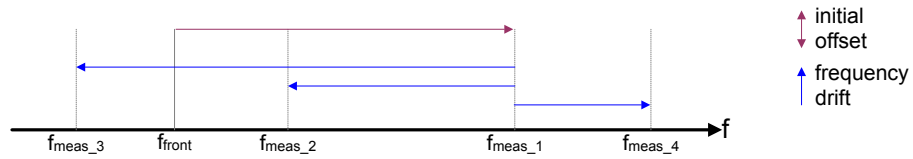

Figure 2-3: Frequency errors

f_{front} = initial frequency set on the frontend

f_{meas_x} = actual frequency that has been measured

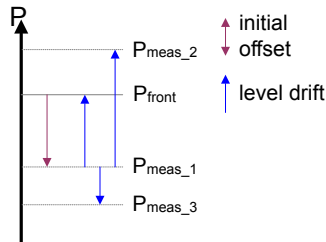

Figure 2-4: Level errors

P_{front} = reference level if tracking = off

P_{front} = initial reference level if tracking = on

P_{meas_1} = becomes reference level after first sweep if tracking = on

P_{meas_2} = becomes reference level after second sweep if tracking = on

P_{meas_3} = becomes reference level after third sweep if tracking = on

Window title bar information

For each diagram, the header provides the following information:



Figure 2-5: Window title bar information of the phase noise application

1 = Window number

2 = Window type

3 = Trace color and number

4 = Trace mode

5 = Smoothing state and degree

Status bar information

Global instrument settings, the instrument status and any irregularities are indicated in the status bar beneath the diagram. Furthermore, the progress of the current operation is displayed in the status bar.

3 Measurements and Result Displays

Access:

The Phase Noise application measures the phase noise of a single sideband of a carrier.

It features several result displays. Result displays are different representations of the measurement results. They may be diagrams that show the results in a graphic way or tables that show the results in a numeric way.

In the default state of the application, only the graphical display of phase noise results is active.

Phase Noise Diagram.....	11
Residual Noise.....	12
Spot Noise.....	13
Spur List.....	14
Sweep Result List.....	15
Spectrum Monitor.....	16
Frequency Drift.....	17
Frequency and Level Stability.....	17
Reference Measurement.....	18

Phase Noise Diagram

The phase noise diagram shows the power level of the phase noise over a variable frequency offset from the carrier frequency.

Measurement range

The unit of both axes in the diagram is fix. The x-axis always shows the offset frequencies in relation to the carrier frequency on a logarithmic scale in Hz. It always has a logarithmic scale to make sure of an equal representation of offsets near and far away from the carrier. The range of offsets that the x-axis shows is variable and depends on the measurement range you have defined and the scope of the x-axis that you have set.

For more information on the measurement range see [Chapter 4.3, "Measurement Range"](#), on page 21.

If the measurement range you have set is necessary, but you need a better resolution of the results, you can limit the displayed result by changing the x-axis scope. The scope works like a zoom to get a better view of the trace at various points. It does not start a new measurement or alter the current measurements results in any way.

The y-axis always shows the phase noise power level contained in a 1 Hz bandwidth in relation to the level of the carrier. The unit for this information is dBc/Hz and is also fix.

Y-axis scale

The scale of the y-axis is variable. Usually it is best to use the automatic scaling that the application provides, because it makes sure that the whole trace is always visible. You can, however, also customize the range, the minimum and the maximum values on the y-axis by changing the y-axis scale.

The measurement results are displayed as traces in the diagram area. Up to six active traces at any time are possible. Each of those may have a different setup and thus show different aspects of the measurement results.

In the default state, the application shows two traces. A yellow one and a blue one. Both result from the same measurement data, but have been evaluated differently. On the first trace, smoothing has been applied, the second one shows the raw data.

For more information on trace smoothing see [Chapter 4.5, "Trace Averaging"](#), on page 22.

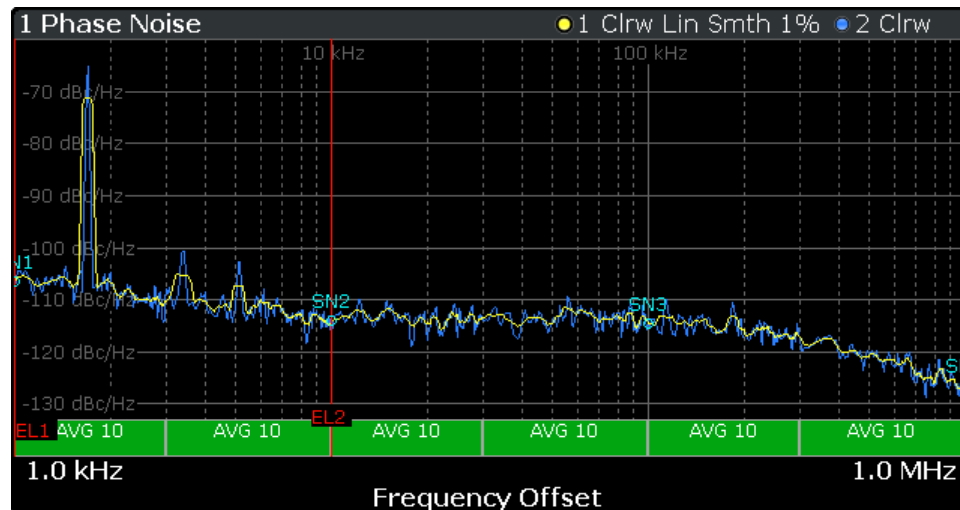

Figure 3-1: Overview of the phase noise result display

The figure above shows a phase noise curve with typical characteristics. Frequency offsets near the carrier usually have higher phase noise levels than those further away from the carrier. The curve has a falling slope until the thermal noise of the DUT has been reached. From this point on, it is more or less a straight horizontal line.

Remote command:

`TRACe<n> [: DATA]` on page 123

Residual Noise

The residual noise display summarizes the residual noise results in a table.

For more information on the residual noise results see [Chapter 4.2, "Residual Effects"](#), on page 20.

The table consists of up to four rows with each row representing a different integration interval. Each row basically contains the same information with the exception that the first row always shows the results for the first trace and the other rows with custom integration ranges the results for any one trace.

2 Residual Noise						
Trace	Start Offset	Stop Offset	Int PHN	PM	FM	Jitter
T1	1.00 kHz	10.00 kHz	-50.15 dBc	251.81 m° / 4...	7.72 Hz	134.52 fs
T1	10.00 kHz	100.00 kHz	-63.80 dBc	52.32 m° / 91...	55.32 Hz	27.95 fs
T1	100.00 kHz	200.68 kHz	-64.34 dBc	49.17 m° / 85...	129.94 Hz	26.26 fs

The residual noise information is made up out of several values.

Type	Shows the number of the trace that is integrated (T[x]).
Start / Stop Offset	Shows the start and stop offset of the integration interval.
Int. PHN	Shows the Integrated Phase Noise. The integral is calculated over the frequency range defined by the Start and Stop Offset values.
PM	Shows the Residual PM result in degrees and rad.
FM	Shows the Residual FM results in Hz.
Jitter	Shows the Jitter in seconds.

For more information on residual noise see [Chapter 4.2, "Residual Effects"](#), on page 20.

Remote command:

Querying Residual PM:

`FETCh:PNOise<t>:USER<range>:RPM?` on page 128

Querying Residual FM:

`FETCh:PNOise<t>:USER<range>:RFM?` on page 128

Querying Jitter:

`FETCh:PNOise<t>:USER<range>:RMS?` on page 128

Querying Integrated Phase Noise

Querying user ranges:

`FETCh:PNOise<t>:USER<range>:RFM?` on page 128

`FETCh:PNOise<t>:USER<range>:RMS?` on page 128

`FETCh:PNOise<t>:USER<range>:RPM?` on page 128

Spot Noise

Spot noise is the phase noise at a particular frequency offset (or spot) that is part of the measurement range. It is thus like a fixed marker.

The unit of spot noise results is dBc/Hz. The application shows the results in a table.

2 Spot Noise		
Type	Offset Frequency [T1]	Phase Noise [T1]
User 1	1.00 kHz	-115.33 dBc/Hz
User 2	10.00 kHz	-124.42 dBc/Hz
User 3	100.00 kHz	-122.67 dBc/Hz
User 4	1.00 MHz	-132.82 dBc/Hz
User 5	10.00 MHz	---

The table consists of a variable number of 10^x frequencies (depending on the measurement range), and a maximum of five user frequencies, with each row containing the spot noise information for a particular frequency offset.

The spot noise information is made up out of several variables.

Type	Shows where the spot noise offset frequency comes from. By default, the application evaluates the spot noise for the first offset frequency of a decade only (10 ^x Hz, beginning at 1 kHz). However, you can add up to five customized offsets frequencies that you want to know the phase noise for. If you want to use more custom offsets, you can add another spot noise table. The "User" label indicates a custom offset frequency.
Offset Frequency	Shows the offset frequency the spot noise is evaluated for. You may add any offset that is part of the measurement range. The number in brackets (T<x>) indicates the trace the result refers to.
Phase Noise	Shows the phase noise for the corresponding offset frequency. The number in brackets (T<x>) indicates the trace the result refers to.

Note that the spot noise results are calculated for a particular trace only. You can select the trace by tapping on the trace LED in the header of the result display.

1 Phase Noise ● 1 Clrw Lin Smth 1% ○ 2 Clrw

Remote command:

Querying spot noise results on 10^x offset frequencies:

[CALCulate<n>:SNOise<m>:DECades:X](#) on page 130

[CALCulate<n>:SNOise<m>:DECades:Y](#) on page 130

Querying custom spot noise results:

[CALCulate<n>:SNOise<m>:Y](#) on page 131

Trace selection: [DISPlay\[:WINDow<n>\]:TRACe<t>:SElect](#) on page 132

Spur List

Spurs are peak levels at one or more offset frequencies and are caused mostly by interfering signals. The application shows the location of all detected spurs in a table.

4 Spur List			
No	Offset Frequency	Power	Jitter
1	1.70 kHz	-50.20 dBc	133.82 fs
2	3.40 kHz	-80.59 dBc	4.04 fs
3	5.10 kHz	-82.42 dBc	3.28 fs
Total	Discrete Jitter		133.92 fs
	Random Jitter		12.62 fs

The table consists of a variable number of rows. For each detected spur, the table shows several results.

Number	Shows the spur number. Spurs are sorted by their frequency, beginning with the spur with the lowest frequency.
Offset Frequency	Shows the position (offset frequency) of the spur.

Power	Shows the power level of the spur in dBc.
Jitter	Shows the jitter value of the spur in s. In addition to the jitter for each spur, the result display also shows the Discrete Jitter and the Random Jitter at the end of the table. <ul style="list-style-type: none"> The Discrete Jitter is the RMS value of all individual jitter values. The Random Jitter is the difference of the overall jitter (as shown in the Residual Noise result display) and the Discrete Jitter. The result is an RMS value: $\text{RandomJitter}^2 = \text{Jitter}^2 - \text{DiscreteJitter}^2$

For more information see [Chapter 4.1, "Spurs and Spur Removal"](#), on page 19.

Remote command:

[FETCh:PNOise<t>:SPURs?](#) on page 132

[FETCh:PNOise<t>:SPURs:DISCcrete?](#) on page 133

[FETCh:PNOise<t>:SPURs:RANDom?](#) on page 133

Sweep Result List

The sweep result list summarizes the results of the phase noise measurement.

3 Sweep Result List						
Start	Stop	Sampling Rate	AVG	Freq Drift	Level Drift	Max Freq Drift
300.00 Hz	1.00 kHz	2.50 kHz	134	3.32 Hz	0.08 dB	35.94 mHz
1.00 kHz	3.00 kHz	7.50 kHz	1000	3.33 Hz	0.08 dB	82.92 mHz
3.00 kHz	10.00 kHz	25.00 kHz	1000	3.33 Hz	0.08 dB	219.37 mHz
10.00 kHz	30.00 kHz	75.00 kHz	1000	3.32 Hz	0.08 dB	553.48 mHz
30.00 kHz	100.00 kHz	250.00 kHz	1000	3.33 Hz	0.08 dB	2.17 Hz
100.00 kHz	300.00 kHz	750.00 kHz	1000	3.33 Hz	0.08 dB	11.45 Hz
300.00 kHz	1.00 MHz	2.50 MHz	1000	3.33 Hz	0.08 dB	105.11 Hz

The table consists of several rows with each row representing a half decade. The number of rows depends on the number of half decades analyzed during the measurement.

The sweep results are made up out of several values.

- Results in a red font indicate that the frequency drift is so large that the frequency has drifted into the range of a higher half decade. The result is therefore invalid.
- Results in a green font indicate the half decade that is currently measured.

Start / Stop	Shows the start and stop offset of the half decade.
Sampling Rate	Shows the sample rate used in the corresponding half decade.
AVG	Shows the number of measurements performed in the half decade to calculate the average (final) result.
Freq Drift	Shows the difference to the initial (nominal) frequency that was measured in the half decade. If you perform more than one measurement (averages) in the half decade, the value is updated for each single measurement. The last value that has been measured in the half decade will remain in the table.

Max Drift	Shows the highest difference to the initial (nominal) frequency that was measured in the half decade.
Level Drift	Shows the difference to the initial (nominal) level that was measured in the half decade. If you perform more than one measurement (averages) in the half decade, the value is updated for each single measurement. The last value that has been measured in the half decade will remain in the table.

Remote command:

Start offset: `FETCh:PNOise<t>:SWEep:START?` on page 136

Stop offset: `FETCh:PNOise<t>:SWEep:STOP?` on page 137

Sample rate: `FETCh:PNOise<t>:SWEep:SRATe?` on page 136

Averages: `FETCh:PNOise<t>:SWEep:AVG?` on page 134

Frequency drift: `FETCh:PNOise<t>:SWEep:FDRift?` on page 135

Max drift: `FETCh:PNOise<t>:SWEep:MDRift?` on page 135

Level drift: `FETCh:PNOise<t>:SWEep:LDRift?` on page 135

Spectrum Monitor

The spectrum monitor shows the spectrum for the half decade that is currently measured.

Span

The span on the x-axis is defined by the start and stop frequency of the half decade that is currently measured.

Y-axis scale

The scale of the y-axis is automatically determined according to the signal characteristics.

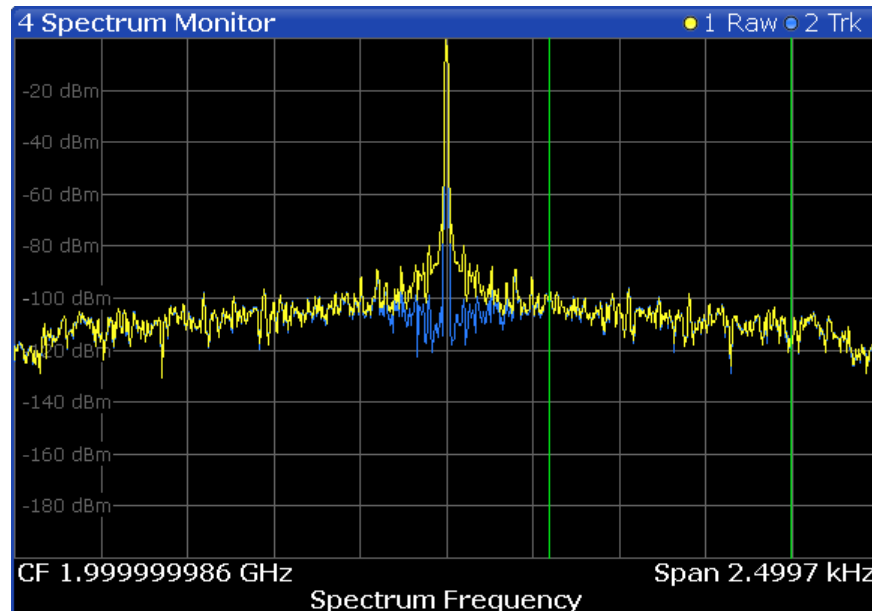

In I/Q mode, the result display contains two traces.

- The yellow trace ("raw trace") represents the live signal with the actual center frequency currently measured.

- The blue trace ("track trace") equalizes frequency drifting signals and thus shows a stable version of the signal with the intended center frequency.

If necessary, you can turn the traces on and off. For more information see "[Spectrum Monitor: Raw Trace / Trk Trace \(On Off\)](#)" on page 51.

The green vertical lines indicate the phase noise offset to be measured on in relation to the displayed center frequency. The position of the two green lines depends on the half decade that is currently measured and the sample rate you have selected.

Remote command:

`TRACe<n> [: DATA]` on page 123

Frequency Drift

The frequency drift shows the instantaneous frequency over time for the half decade that is currently measured.

Time span

The displayed time span on the x-axis is defined by the time it takes to perform a measurement in the half decade that is currently measured. If the measurement time for a particular half decade is very long (several seconds), the application probably updates the result display several times. In that case, the application splits the measurement into several "sub-measurements".

Y-axis scale

The scale of the y-axis is automatically determined according to the sample rate. For a better resolution, the trace is offset by the first measured frequency value. Thus, the trace always starts at 0 Hz. The initial correction value is displayed in the diagram as a numeric result.

To get a better resolution of the time axis, use the zoom function.

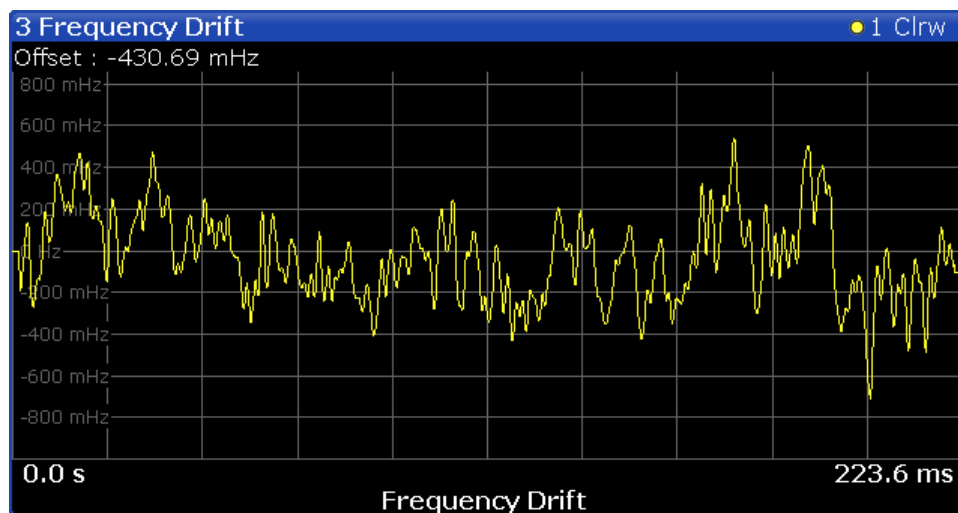



Frequency and Level Stability

The stability results show the current level and frequency drift characteristics of the carrier signal compared to the initial frequency and level. In addition to the numerical results, the result display also contains a graphical representation of the drift characteristics.

The result display contains the following results.

- **Carrier Stability**
Difference between the 1st frequency that has been measured and the frequency that has been measured last.
- **Δ to Ref Level**
Difference between the 1st level that has been measured and the level that has been measured last.

2 Frequency & Level Stability				
Type	Indicator		Value	
Carrier Stability	-3.75 kHz		3.75 kHz	130.00 mHz
Δ to Ref Level				-0.57 dB

The results correspond to the Level Drift and Frequency Drift results displayed in the channel bar. For more information see ["Channel bar information"](#) on page 9

Note that the results are only valid for I/Q FFT measurements (see ["Global Sweep Mode"](#) on page 42).

Reference Measurement

The reference measurement measures the inherent noise figure (DANL) of the R&S FPS.

To determine the inherent noise, you must remove the signal from the input. The application then performs a measurement without the signal. The resulting trace shows the inherent noise of the R&S FPS only. When you subtract that inherent noise from the phase noise of the measurement with trace mathematics, you get a trace that shows the phase noise of the DUT only.

Remote command:

[CONFigure:REFMeas](#) on page 78

4 Measurement Basics

The measurement basics contain background information on the terminology and principles of phase noise measurements.

Phase noise measurements in general determine the single sideband phase noise characteristics of a device under test (DUT).

• Spurs and Spur Removal	19
• Residual Effects	20
• Measurement Range	21
• Sweep Modes	22
• Trace Averaging	22
• Frequency Determination	24
• Level Determination	27
• Signal Attenuation	27
• Using Limit Lines	28
• Analyzing Several Traces - Trace Mode	30
• Using Markers	32

4.1 Spurs and Spur Removal

Most phase noise results contain unwanted spurs. Spurs are peak levels at one or more offset frequencies and are caused mostly by interfering signals. For some applications, you might want to identify the location of spurs. For other applications, spurs do not matter in evaluating the results and you might want to remove them from the trace to get a "smooth" phase noise trace.

Spur display

Usually, spurs are visible on the trace as a peak. In addition, the R&S FPS draws a straight, vertical line to represent the position of a spur visually. The length of these lines indicates the level of the spur in dBc and refers to the scale on the right side of the phase noise diagram.

The lines indicating a spur are not part of the trace data. When you export the trace, for example, the spur data is not exported.

Spur suppression

The application allows you to (visually) remove spurs from the trace. Spur removal is based on an algorithm that detects and completely removes the spurs from the trace and fills the gaps with data that has been determined mathematically.

The spur removal functionality separates the actual spur power from the underlying phase noise and displays the latter in a two-stage process. The first stage of spur detection is based on an eigenvalue decomposition during the signal processing.

Spur threshold

During the second stage, the application uses statistical methods to remove a spur. A spur is detected, if the level of the signal is above a certain threshold. The spur threshold is relative to an imaginary median trace that the application calculates.

If parts of the signal are identified as spurs, the application removes all signal parts above that level and substitutes them with the median trace.

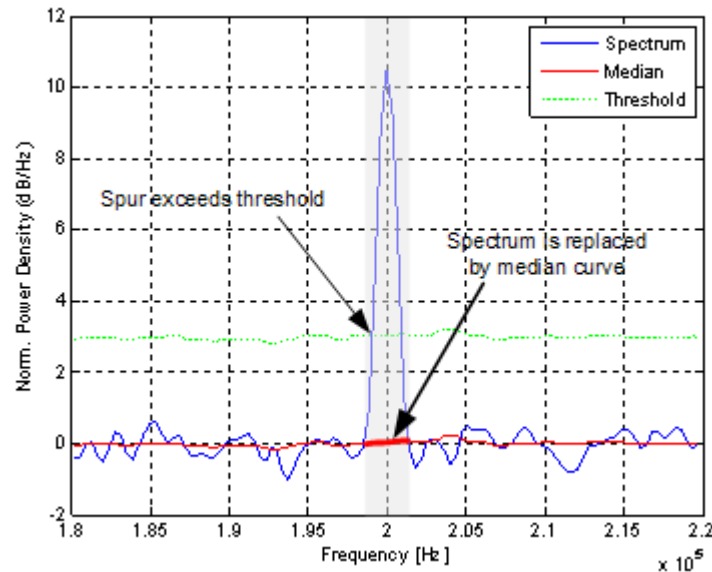

Figure 4-1: Spur detection and removal principle

4.2 Residual Effects

Residual noise effects are modulation products that originate directly from the phase noise. It is possible to deduce them mathematically from the phase noise of a DUT.

The application calculates three residual noise effects. All calculations are based on an integration of the phase noise over a particular offset frequency range.

Residual PM

The residual phase modulation is the contribution of the phase noise to the output of a PM demodulator. It is evaluated over the frequency range you have defined.

$$\text{Residual PM} = \sqrt{2 \cdot \int_{f_{\text{start}}}^{f_{\text{stop}}} L(f_m) df_m} \text{ [rad]}$$

with $L(f)$ = single sideband phase noise [dBc/Hz]

Residual FM

The residual frequency modulation is the contribution of the phase noise to the output of an FM demodulator. It is evaluated over the frequency range you have defined.

$$\text{Residual FM} = \sqrt{2 \cdot \int_{f_{\text{start}}}^{f_{\text{stop}}} f_m^2 L(f_m) df_m} \text{ [Hz]}$$

with $L(f_m)$ = single sideband phase noise [dBc/Hz]

f_m = frequency [Hz]

Jitter

The jitter is the RMS temporal fluctuation of a carrier with the given phase noise evaluated over a given frequency range of interest.

$$\text{Jitter[s]} = \frac{\text{Residual PM [rad]}}{2\pi \cdot f_0}$$

with f_0 = Carrier frequency

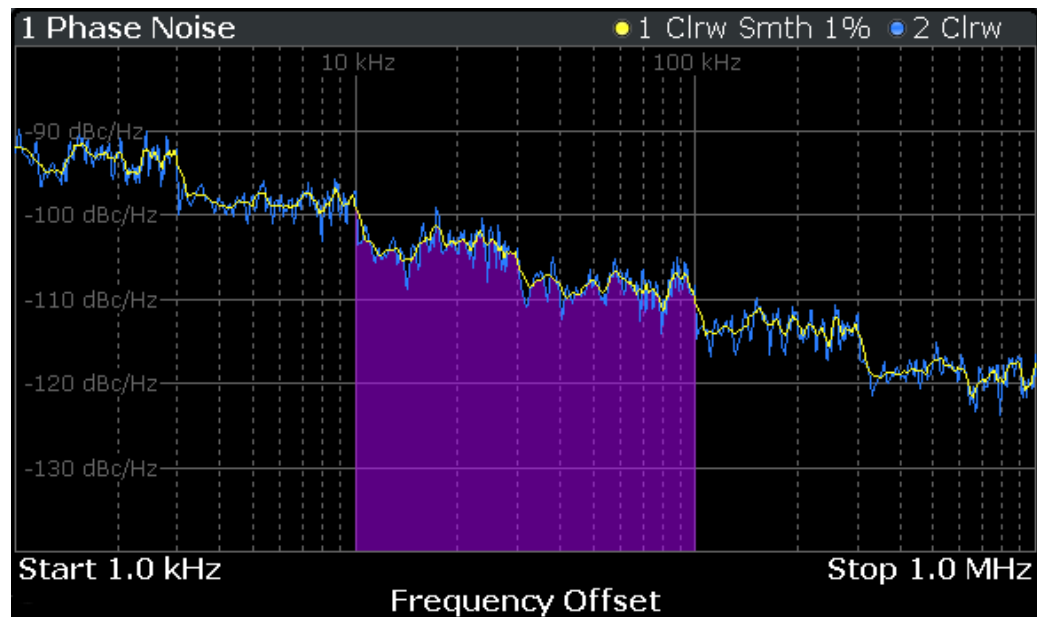

Figure 4-2: Residual noise based on an integration between 10 kHz and 100 kHz offset

4.3 Measurement Range

Noise measurements determine the noise characteristics of a DUT over a particular measurement range. This **measurement range** is defined by two offset frequencies. The **frequency offsets** themselves are relative to the nominal frequency of the DUT.

The measurement range again is divided into several (logarithmic) decades, or, for configuration purposes, into **half decades**.

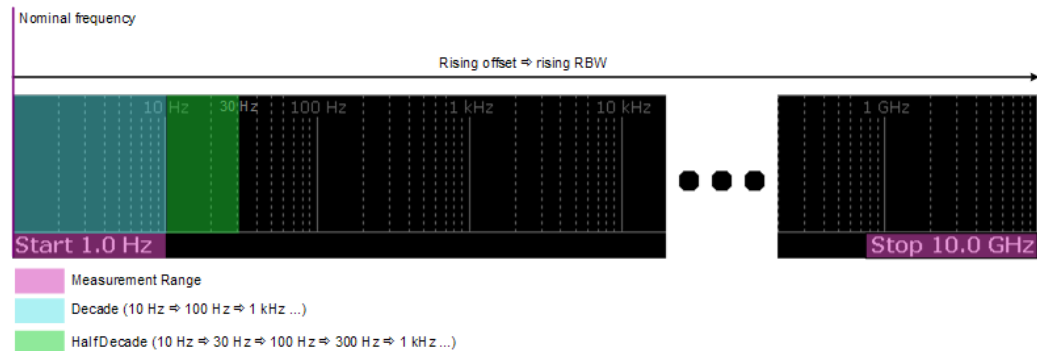

Figure 4-3: Measurement range and half decades

This breakdown into several half decades is made to speed up measurements. You can configure each half decade separately in the "Half Decade Configuration Table". For quick, standardized measurements, the application provides several predefined sweep types or allows you to configure each half decade manually, but globally.

The main issue in this context is the **resolution bandwidth (RBW)** and its effect on the measurement time. In general, it is best to use a resolution bandwidth as small as possible for the most accurate measurement results. However, accuracy comes at the price of measurement speed.

To avoid long measurement times, the application provides only a certain range of RBWs that are available for each half decade.

4.4 Sweep Modes

Sweep modes define the data processing method.

Swept

The application performs a sweep of the frequency spectrum.

I/Q FFT

The application evaluates the I/Q data that has been collected and calculates the trace based on that data.

4.5 Trace Averaging

The application provides several methods of trace averaging that you can use separately or in any combination.

The order in which averaging is performed is as follows.

1. Half decade averaging.
The application measures each half decade a particular number of times before measuring the next one.
2. Cross-correlation
The application performs a certain number of cross-correlation operations in each half decade.
3. Sweep count.
The application measures the complete measurement range a particular number of times.
It again includes half decade averaging as defined.
After the measurement over the sweep count is finished, the application displays the averaged results.
4. Trace smoothing.
Calculates the moving average for the current trace.

4.5.1 Half Decade Averaging

Define the number of measurements that the application performs for each half decade before it displays the averaged results and measures the next half decade.

In combination with the RBW, this is the main factor that affects the measurement time. Usually, a small number of averages is sufficient for small RBWs, because small RBWs already provide accurate results, and a high number of averages for high RBWs to get more balanced results.

4.5.2 Sweep Count

The sweep count defines the number of sweeps that the application performs during a complete measurements.

A sweep in this context is the measurement over the complete measurement range once. A complete measurement, however, can consist of more than one sweep. In that case, the application measures until the number of sweeps that have been defined are done. The measurement configuration stays the same all the time.

In combination with the average trace mode and half decade averaging, the sweep count averages the trace even more.

4.5.3 Trace Smoothing

(Software-based) **smoothing** is a way to remove anomalies visually in the trace that can distort the results. The smoothing process is based on a moving average over the complete measurement range. The number of samples included in the averaging process (the *aperture* size) is variable and is a percentage of all samples that the trace consists of.

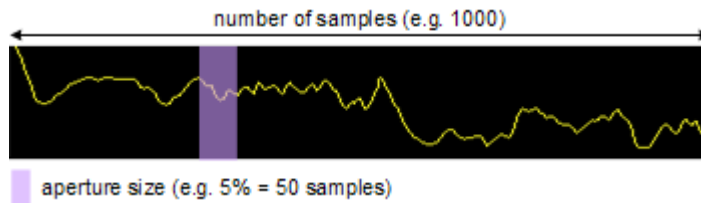

Figure 4-4: Sample size included in trace smoothing

The application smooths the trace only after the measurement has been finished and the data has been analyzed and written to a trace. Thus, smoothing is just an enhancement of the trace display, not of the data itself. This also means that smoothing is always applied after any other trace averagings have been done, as these happen during the measurement itself.

You can turn trace smoothing on and off for all traces individually and compare, for example, the raw and the smooth trace.

Linear smoothing is based on the following algorithm:

$$y'(s) = \frac{1}{n} \left(\sum_{x=s-\frac{n-1}{2}}^{x=s+\frac{n-1}{2}} y(x) \right)$$

Equation 4-1: Linear trace smoothing

Logarithmic smoothing is based on the following algorithm:

$$y'(s) = 10 \cdot \log_{10} \left(\frac{1}{n} \left(\sum_{x=s-\frac{n-1}{2}}^{x=s+\frac{n-1}{2}} 10^{\left(\frac{y(x)}{10} \right)} \right) \right)$$

Equation 4-2: Logarithmic trace smoothing

$y(s)$ = logarithmic phase noise level

4.6 Frequency Determination

Nominal frequency

The nominal frequency is the output or center frequency of the DUT. To get correct and valid measurement results, the application needs to know the real frequency of the DUT.



Unverified signals

The R&S FPS tries to start the measurement as soon as you enter the phase noise application. If it cannot verify a signal, it will try to start the measurement over and over. To stop the repeated (and probably unsuccessful) signal verification, stop the measurement on the first verification failure.

The available (nominal) frequency range depends on the hardware you are using. For more information see the datasheet of the R&S FPS.

If you are not sure about the nominal frequency, define a tolerance range to verify the frequency. For measurements on unstable or drifting DUTs, use the frequency tracking functionality.

Frequency verification

When you are using frequency verification, the application initiates a measurement that verifies that the frequency of the DUT is within a certain range of the nominal frequency. This measurement takes place before the actual phase noise measurement. Its purpose is to find strong signals within a frequency tolerance range and, if successful, to adjust the nominal frequency and lock onto that new frequency. The frequency tolerance is variable. You can define it in absolute or relative terms.

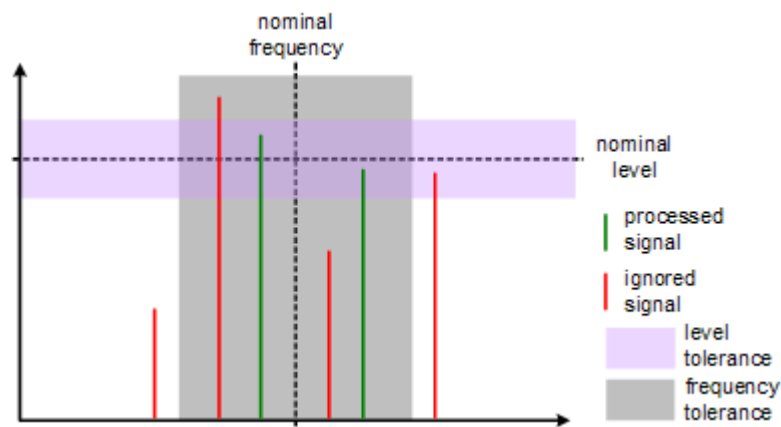

Figure 4-5: Frequency and level tolerance

You can define both absolute and relative tolerances. In that case, the application uses the higher tolerance to determine the frequency.

If there is no signal within the tolerance range, the application aborts the phase noise measurement.

In the numerical results, the application always shows the frequency the measurement was actually performed on. If the measured frequency is not the same as the nominal frequency, the numerical results also show the deviation from the nominal frequency.

Frequency tracking

When you are using the frequency tracking, the application tracks drifting frequencies of unstable DUTs. It internally adjusts and keeps a lock on the nominal frequency of the DUT.

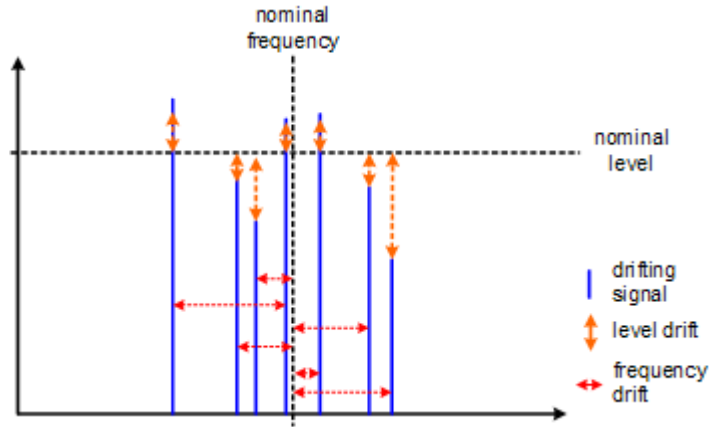

Figure 4-6: Frequency and level tracking

Tracking bandwidth

The tracking bandwidth defines the bandwidth within which the application tracks the frequency.

Normally, the application adjusts the sample rate to the half decade it is currently measuring. For half decades that are near the carrier, the sample rate is small. Half decades far from the carrier use a higher sample rate. However, in case of drifting signals, this method may result in data loss because the default bandwidth for a half decade might be too small for the actual drift in the frequency. In that case, you can define the tracking bandwidth which increases the sample rate if necessary and thus increases the chance to capture the signal.

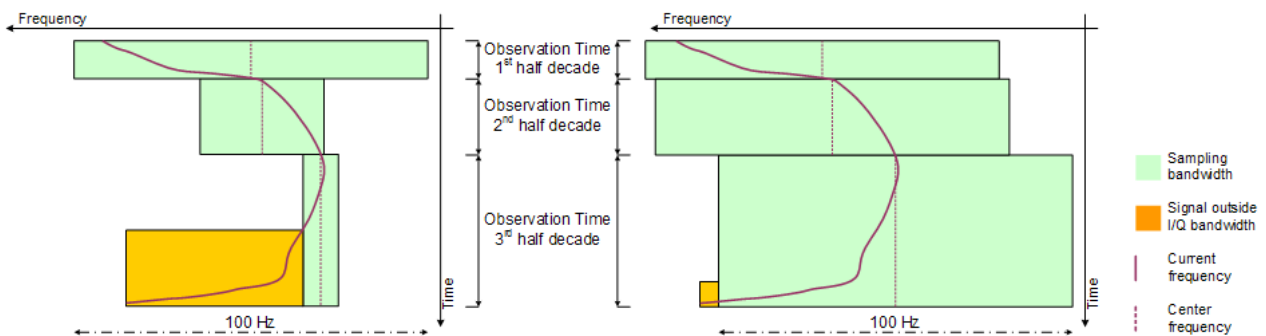

Figure 4-7: Frequency tracking with tracking bandwidth turned off (left) and a tracking bandwidth of 100 Hz (right)

4.7 Level Determination

Nominal level

The nominal level in other terms is the reference level of the R&S FPS. This is the level that the analyzer expects at the RF input.

The available level range depends on the hardware. For more information see the datasheet of the R&S FPS.

Make sure to define a level that is as close to the level of the DUT to get the best dynamic range for the measurement. At the same time make sure that the signal level is not higher than the reference level to avoid an overload of the A/D converter and thus deteriorating measurement results.

If you are not sure about the power level of the DUT, but would still like to use the best dynamic range and get results that are as accurate as possible, you can verify or track the level.

Level verification

When you are using the level verification, the application initiates a measurement that determines the level of the DUT. If the level of the DUT is within a certain tolerance range, it will adjust the nominal level to that of the DUT. Else, it will abort the phase noise measurement.

Define a level tolerance in relation to the current nominal level. The tolerance range works for DUT levels that are above or below the current nominal level.

Level tracking

For tests on DUTs whose level varies, use level tracking. If active, the application keeps track of the DUTs level during the phase noise measurement and adjusts the nominal level accordingly.

For a graphical representation of level verification and level tracking see the figures in [Chapter 4.6, "Frequency Determination"](#), on page 24.

4.8 Signal Attenuation

Attenuation of the signal may become necessary if you have to reduce the power of the signal that you have applied. Power reduction is necessary, for example, to prevent an overload of the input mixer. An overload of the input mixer may lead to incorrect measurement results or damage to the hardware if the signal power is too strong.

In the default state, the application automatically determines the attenuation according to the reference level. If necessary, you can also define the attenuation manually.

When you attenuate the signal, the application adjusts graphical and numerical results accordingly.

Because the reference level and attenuation are interdependent, changing the attenuation manually may also adjust the reference level.

RF attenuation

RF attenuation is always available. It is a combination of mechanical and IF attenuation.

The mechanical attenuator is located directly after the RF input of the R&S FPS. Its step size is 5 dB. IF attenuation is applied after the signal has been down-converted. Its step size is 1 dB.

Thus, the step size for RF attenuation as a whole is 1 dB. Mechanical attenuation is used whenever possible (attenuation levels that are divisible by 5). IF attenuation handles the 1 dB steps only.

Example:

If you set an attenuation level of 18 dB, 15 dB are mechanical attenuation and 3 dB are IF attenuation.

If you set an attenuation level of 6 dB, 5 dB are mechanical attenuation and 1 dB is IF attenuation.

Electronic attenuation

Electronic attenuation is available with R&S FPS-B25. You can use it in addition to mechanical attenuation. The step size of electronic attenuation is 1 dB with attenuation levels not divisible by 5 again handled by the IF attenuator. Compared to RF attenuation, you can define the amount of mechanical and electronic attenuation freely.

4.9 Using Limit Lines

Limit lines provide an easy way to verify if measurement results are within the limits you need them to be. As soon as you turn a limit line on, the application will indicate if the phase noise a trace displays is in line with the limits or if it violates the limits.

The application provides two kinds of limit lines. 'Normal' limit lines as you know them from the Spectrum application and special thermal limit lines for easy verification of thermal noise results.

Phase noise limit lines

Phase noise limit lines have been designed specifically for phase noise measurements. Their shape is based on the thermal noise floor of the DUT and the typical run of the phase noise curve.

The typical slope of the phase noise curve depends on the offset from the DUT frequency. In the white noise range (the noise floor), far away from the carrier, the slope is more or less 0 dB per frequency decade. In the colored noise segment, the slope is greater than 0 dB. The slope, however, is not constant in that segment, but again is typical for various carrier offset segments (or ranges).

The application supports the definition of up to five ranges, each with a different slope. The ranges themselves are defined by corner frequencies. Corner frequencies are those frequencies that mark the boundaries of typical curve slopes. If you use all five ranges, the result would be a limit line with six segments.

All segments have a slope of 10 dB per decade (f^{-1}) by default.

In most cases, these special limit lines will suffice for phase noise measurements as they represent the typical shape of a phase noise curve.

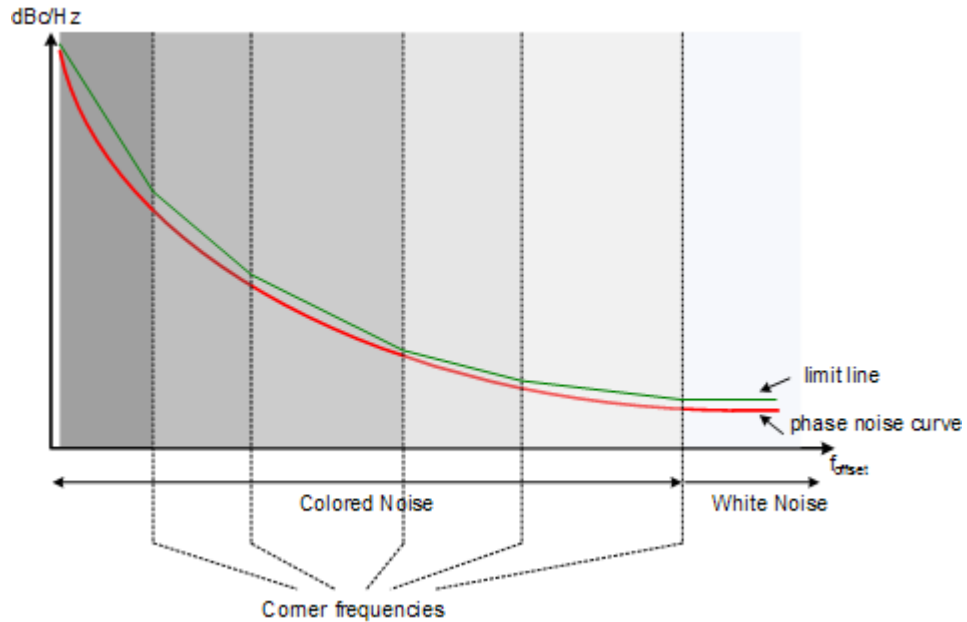

Figure 4-8: Typical looks of a special limit line

Normal limit lines

Normal limit lines on the other hand may have any shape and may consist of up to 200 data points. You can turn on up to 8 normal limit lines at the same time. Each of those limit lines can test one or several traces.

If you want to use them for phase noise measurements however, a limit line must be scaled in the unit dBc/Hz and must be defined on a logarithmic scale on the horizontal axis.

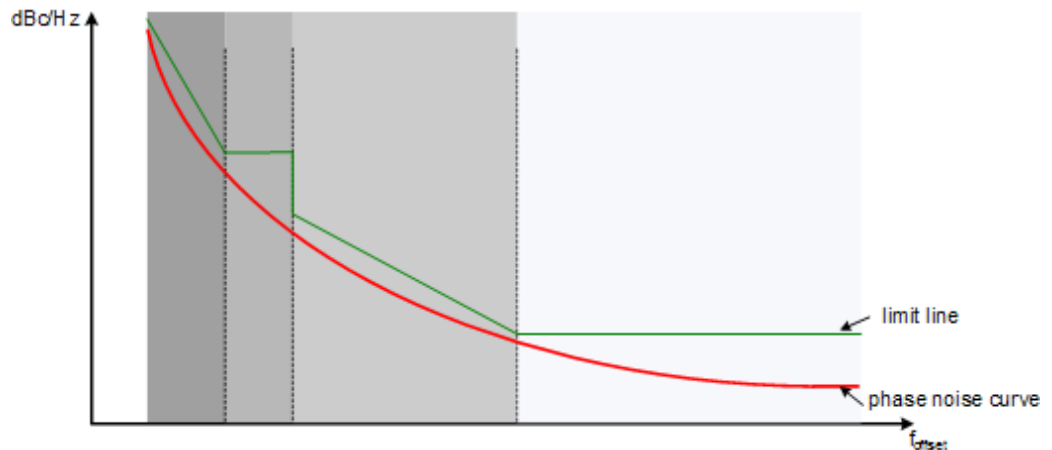

Figure 4-9: Possible looks of a normal limit line

4.10 Analyzing Several Traces - Trace Mode

If several sweeps are performed one after the other, or continuous sweeps are performed, the trace mode determines how the data for subsequent traces is processed. After each sweep, the trace mode determines whether:

- the data is frozen (View)
- the data is hidden (Blank)
- the data is replaced by new values (Clear Write)
- the data is replaced selectively (Max Hold, Min Hold, Average)



Each time the trace mode is changed, the selected trace memory is cleared.

The R&S FPS provides the following trace modes:

Table 4-1: Overview of available trace modes

Trace Mode	Description
Blank	Hides the selected trace.
Clear Write	Overwrite mode: the trace is overwritten by each sweep. This is the default setting.
Max Hold	The maximum value is determined over several sweeps and displayed. The R&S FPS saves the sweep result in the trace memory only if the new value is greater than the previous one.
Min Hold	The minimum value is determined from several measurements and displayed. The R&S FPS saves the sweep result in the trace memory only if the new value is lower than the previous one.
Average	The average is formed over several sweeps. The sweep count determines the number of averaging procedures.
View	The current contents of the trace memory are frozen and displayed.



If a trace is frozen ("View" mode), the instrument settings, apart from level range and reference level, can be changed without impact on the displayed trace. The fact that the displayed trace no longer matches the current instrument setting is indicated by the  icon on the tab label.

If the level range or reference level is changed, the R&S FPS automatically adapts the trace data to the changed display range. This allows an amplitude zoom to be made after the measurement in order to show details of the trace.

Trace averaging algorithm

In "Average" trace mode, the sweep count determines how many traces are averaged. The more traces are averaged, the smoother the trace is likely to become.

The algorithm for averaging traces depends on the sweep mode and sweep count.

- sweep count = 0 (default)
In continuous sweep mode, a continuous average is calculated for 10 sweeps, according to the following formula:

$$Trace = \frac{9 * Trace_{old} + MeasValue}{10}$$

Figure 4-10: Equation 1

Due to the weighting between the current trace and the average trace, past values have practically no influence on the displayed trace after about ten sweeps. With this setting, signal noise is effectively reduced without need for restarting the averaging process after a change of the signal.

- sweep count = 1
The currently measured trace is displayed and stored in the trace memory. No averaging is performed.
- sweep count > 1
For both "Single Sweep" mode and "Continuous Sweep" mode, averaging takes place over the selected number of sweeps. In this case the displayed trace is determined during averaging according to the following formula:

$$Trace_n = \frac{1}{n} \cdot \left[\sum_{i=1}^{n-1} (T_i) + MeasValue_n \right]$$

Figure 4-11: Equation 2

where n is the number of the current sweep (n = 2 ... Sweep Count).

No averaging is carried out for the first sweep but the measured value is stored in the trace memory. With increasing n, the displayed trace is increasingly smoothed since there are more individual sweeps for averaging.

After the selected number of sweeps the average trace is saved in the trace memory. Until this number of sweeps is reached, a preliminary average is displayed.

When the averaging length defined by the "Sweep Count" is attained, averaging is continued in continuous sweep mode or for "Continue Single Sweep" according to the following formula:

$$Trace = \frac{(N-1) * Trace_{old} + MeasValue}{N}$$

where N is the sweep count

4.11 Using Markers

Markers are used to mark points on traces, to read out measurement results and to select a display section quickly. The application provides 4 markers.

By default, the application positions the marker on the lowest level of the trace. You can change a marker position in several ways.

- Enter a particular offset frequency in the input field that opens when you activate a marker.
- Move the marker around with the rotary knob or the cursor keys.
- Drag the marker to a new position using the mouse pointer.

4.11.1 Marker Types

All markers can be used either as normal markers or delta markers. A normal marker indicates the absolute signal value at the defined position in the diagram. A delta marker indicates the value of the marker relative to the specified reference marker (by default marker 1).

In addition, special functions can be assigned to the individual markers. The availability of special marker functions depends on whether the measurement is performed in the frequency or time domain.

4.11.2 Activating Markers

Only active markers are displayed in the diagram and in the marker table. Active markers are indicated by a highlighted softkey.

By default, marker 1 is active and positioned on the maximum value (peak) of trace 1 as a normal marker. If several traces are displayed, the marker is set to the maximum value of the trace which has the lowest number and is not frozen (View mode). The next marker to be activated is set to the frequency of the next lower level (next peak) as a delta marker; its value is indicated as an offset to marker 1.

A marker can only be activated when at least one trace in the corresponding window is visible. If a trace is switched off, the corresponding markers and marker functions are also deactivated. If the trace is switched on again, the markers along with coupled functions are restored to their original positions, provided the markers have not been used on another trace.

5 Configuration

Access: [MODE] > "Phase Noise"

When you activate a measurement channel in the Phase Noise application, a measurement for the input signal is started automatically with the default configuration. The "Phase Noise" menu is displayed and provides access to the most important configuration functions.

For a description see

- [Chapter 5.3, "Configuring the Frontend"](#), on page 35
- [Chapter 5.4, "Controlling the Measurement"](#), on page 37
- [Chapter 5.5, "Configuring the Measurement Range"](#), on page 40
- [Chapter 6.3, "Using Limit Lines"](#), on page 56
- [Chapter 6.1, "Configuring Graphical Result Displays"](#), on page 47
- [Chapter 6.2, "Configure Numerical Result Displays"](#), on page 54



Automatic refresh of preview and visualization in dialog boxes after configuration changes

The R&S FPS supports you in finding the correct measurement settings quickly and easily - after each change in settings in dialog boxes, the preview and visualization areas are updated immediately and automatically to reflect the changes. Thus, you can see if the setting is appropriate or not before accepting the changes.

- [Configuration Overview](#).....33
- [Default Settings for Phase Noise Measurements](#).....35
- [Configuring the Frontend](#).....35
- [Controlling the Measurement](#).....37
- [Configuring the Measurement Range](#).....40
- [Performing Measurements](#).....43
- [Configuring In- and Outputs](#).....45
- [Automatic Measurement Configuration](#).....45

5.1 Configuration Overview



Throughout the measurement channel configuration, an overview of the most important currently defined settings is provided in the "Overview". The "Overview" is displayed when you select the "Overview" icon, which is available at the bottom of all softkey menus.

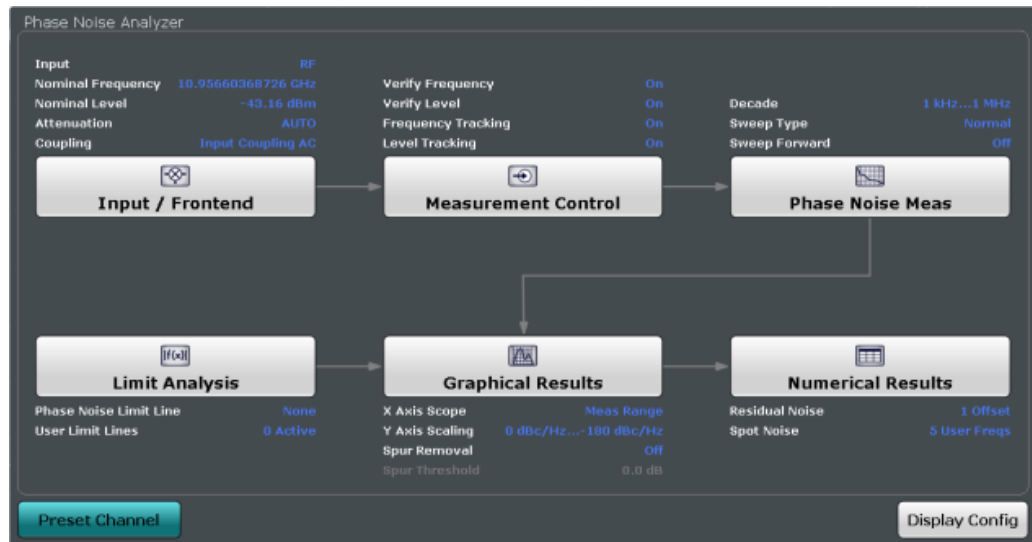

In addition to the main measurement settings, the "Overview" provides quick access to the main settings dialog boxes. The individual configuration steps are displayed in the order of the data flow. Thus, you can easily configure an entire measurement channel from input over processing to output and analysis by stepping through the dialog boxes as indicated in the "Overview".

In particular, the "Overview" provides quick access to the following configuration dialog boxes (listed in the recommended order of processing):

1. Frontend
See [Chapter 5.3, "Configuring the Frontend"](#), on page 35.
2. Measurement Control
See [Chapter 5.4, "Controlling the Measurement"](#), on page 37.
3. Phase Noise Measurement
See [Chapter 5.5, "Configuring the Measurement Range"](#), on page 40.
4. Limit Analysis
See [Chapter 6.3, "Using Limit Lines"](#), on page 56.
5. Graphical Results
See [Chapter 6.1, "Configuring Graphical Result Displays"](#), on page 47.
6. Numerical Results
See [Chapter 6.2, "Configure Numerical Result Displays"](#), on page 54.

To configure settings

- ▶ Select any button in the "Overview" to open the corresponding dialog box. Select a setting in the channel bar (at the top of the measurement channel tab) to change a specific setting.

Preset Channel

Select the "Preset Channel" button in the lower left-hand corner of the "Overview" to restore all measurement settings **in the current channel** to their default values.

Do not confuse the "Preset Channel" button with the [Preset] key, which restores the entire instrument to its default values and thus closes **all channels** on the R&S FPS (except for the default channel)!

Remote command:

`SYSTem:PRESet:CHANnel [:EXEC]` on page 77

5.2 Default Settings for Phase Noise Measurements

When you enter the phase noise application for the first time, a set of parameters is passed on from the currently active application:

- nominal or center frequency
- nominal or reference level
- input coupling

After initial setup, the parameters for the measurement channel are stored upon exiting and restored upon re-entering the channel. Thus, you can switch between applications quickly and easily.

Apart from these settings, the following default settings are activated directly after a measurement channel has been set to the Phase Noise application, or after a channel preset:

Table 5-1: Default settings for phase noise measurement channels

Parameter	Value
Attenuation	Auto (0 dB)
Verify frequency & level	On
Frequency & level tracking	Off
Measurement range	1 kHz ... 1 MHz
Sweep type	Normal
X-axis scaling	Measurement range
Y-axis scaling	20 dBc/Hz ... 120 dBc/Hz
Smoothing	1%
Smoothing type	Linear

5.3 Configuring the Frontend

Access: "Overview" > "Input / Frontend"

The "Frontend" tab of the "Measurement Settings" dialog box contains all functions necessary to configure the frontend of the RF measurement hardware.

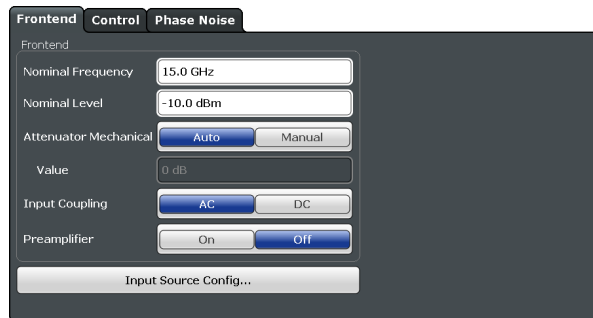

Functions to configure the RF input described elsewhere:

- [Chapter 5.7.1, "Input Source Configuration"](#), on page 45

Nominal Frequency	36
Nominal Level	36
Mechanical Attenuator / Value	36
Coupling	36
Preamplifier (option B22/B24)	37

Nominal Frequency

Defines the nominal frequency of the measurement.

For more information see [Chapter 4.6, "Frequency Determination"](#), on page 24.

Remote command:

[\[SENSe:\] FREQuency:CENTer](#) on page 89

Nominal Level

Defines the nominal level of the R&S FPS.

For more information see [Chapter 4.7, "Level Determination"](#), on page 27

Remote command:

[\[SENSe:\] POWer:RLEVel:VERify\[:STATe\]](#) on page 93

Mechanical Attenuator / Value

Turns mechanical attenuation on and off.

If on, you can define an attenuation level in 5 dB steps.

For more information see [Chapter 4.8, "Signal Attenuation"](#), on page 27.

Remote command:

Turning manual attenuation on and off:

[INPut<ip>:ATTenuation:AUTO](#) on page 90

Defining an attenuation level:

[INPut<ip>:ATTenuation](#) on page 89

Coupling

Selects the coupling method at the RF input.

AC coupling blocks any DC voltage from the input signal. DC coupling lets DC voltage through.

For more information refer to the data sheet.

Remote command:

`INPut<ip>:COUPling` on page 144

Preamplifier (option B22/B24)

Switches the preamplifier on and off. If activated, the input signal is amplified by 20 dB.

If option R&S FPS-B22 is installed, the preamplifier is only active below 7 GHz.

If option R&S FPS-B24 is installed, the preamplifier is active for all frequencies.

Make sure the used preamplifier covers all frequencies to be measured during the phase noise measurement!

The maximum frequency in the phase noise measurement is:

`Nominal Frequency` + Stop offset

Remote command:

`INPut:GAIN:STATe` on page 90

5.4 Controlling the Measurement

Access: "Overview" > "Measurement Control"

The "Control" tab of the "Measurement Settings" dialog box contains all functions necessary to control the sequence of the phase noise measurement.

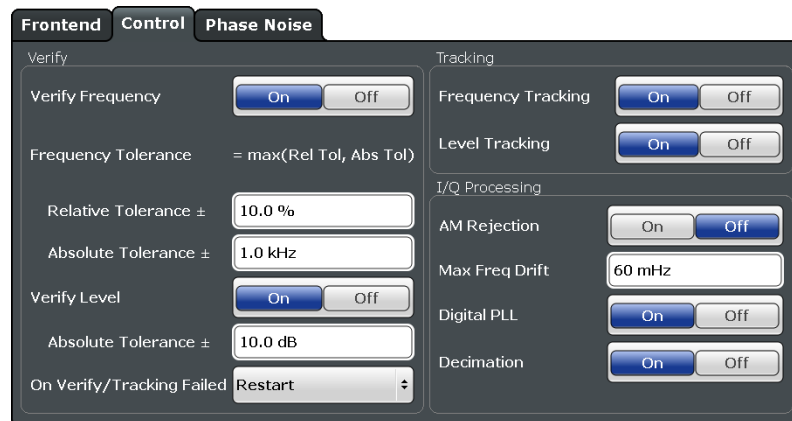

[Verify Frequency](#)..... 38

[Verify Level](#).....38

[On Verify Failed](#).....38

[Frequency Tracking](#).....38

[Level Tracking](#).....39

[AM Rejection](#).....39

[Max Freq Drift](#).....39

[Digital PLL](#).....39

[Decimation](#).....39

Verify Frequency

Turns frequency verification on and off.

If frequency verification is on, the R&S FPS initiates the phase noise measurement only if the frequency of the DUT is within a certain frequency tolerance range. The tolerance range is either a percentage range of the nominal frequency or an absolute deviation from the nominal frequency.

If you define both an absolute and relative tolerance, the application uses the higher tolerance level.

For more information see [Chapter 4.6, "Frequency Determination"](#), on page 24.

Remote command:

Verify frequency:

[\[SENSe:\]FREQuency:VERify\[:STATe\]](#) on page 92

Relative tolerance:

[\[SENSe:\]FREQuency:VERify:TOLerance\[:RELative\]](#) on page 91

Absolute tolerance:

[\[SENSe:\]FREQuency:VERify:TOLerance:ABSolute](#) on page 91

Verify Level

Turns level verification on and off.

If level verification is on, the R&S FPS initiates the phase noise measurement only if the level of the DUT is within a certain level tolerance range. The tolerance range is a level range relative to the nominal level.

For more information see [Chapter 4.7, "Level Determination"](#), on page 27.

Remote command:

Verify level:

[\[SENSe:\]POWer:RLEVel:VERify\[:STATe\]](#) on page 93

Level tolerance:

[\[SENSe:\]POWer:RLEVel:VERify:TOLerance](#) on page 93

On Verify Failed

Selects the way the application reacts if signal verification fails.

Takes effect on both frequency and level verification.

"Restart"	Restarts the measurement if verification has failed.
"Stop"	Stops the measurement if verification has failed.
"Run Auto All"	Starts an automatic frequency and level detection routine if verification has failed. After the new frequency and level have been set, the measurement restarts. For more information see Chapter 5.8, "Automatic Measurement Configuration" , on page 45.

Remote command:

[\[SENSe:\]SWEep:SVFailed](#) on page 94

Frequency Tracking

Turns frequency tracking on and off.

If on, the application tracks the frequency of the DUT during the phase noise measurement and adjusts the nominal frequency accordingly. The application adjusts the frequency after each half decade measurement.

For more information see [Chapter 4.6, "Frequency Determination"](#), on page 24.

Remote command:

[\[SENSe:\] FREQuency: TRACk](#) on page 91

Level Tracking

Turns level tracking on and off.

If on, the R&S FPS tracks the level of the DUT during phase noise measurements and adjusts the nominal level accordingly. The application adjusts the level after each half decade measurement.

For more information see [Chapter 4.7, "Level Determination"](#), on page 27.

Remote command:

[\[SENSe:\] POWer: RLEVel: VERify\[: STATE\]](#) on page 93

AM Rejection

Turns the suppression of AM noise on and off.

If on, the application suppresses the AM noise that the signal contains in order to display phase noise as pure as possible.

AM rejection is available for the I/Q sweep mode.

Remote command:

[\[SENSe:\] REJect: AM](#) on page 94

Max Freq Drift

Defines the minimum bandwidth or sample rate used in the signal processing to increase the probability of capture drifting signals.

The tracking bandwidth is valid for all half decades measured in I/Q mode.

Remote command:

[\[SENSe:\] IQ: TBW](#) on page 93

Digital PLL

Turns an additional frequency correction based on the I/Q data on and off.

If on, the application is able to track frequency changes during the I/Q data capture that would otherwise fall into the half decade measurement bandwidth (see [Max Freq Drift](#)).

The digital PLL works for all half decades measured in I/Q mode.

Remote command:

[\[SENSe:\] IQ: DPLL](#) on page 92

Decimation

Turns decimation on and off.

When you turn on decimation, the samples that have already been used for a given half decade are resampled in lower half decades. Reusing these samples results in lower measurement times in the lower half decades, because less samples have to be recorded there.

To get valid results for lower offset frequencies, make sure to use an appropriate sample rate.

This feature is especially useful when you are measuring half decades with very low offset frequencies.

Using decimation is available for the "I/Q FFT" sweep mode.

Remote command:

[SENSe:] IQ:DECimation on page 92

5.5 Configuring the Measurement Range

Access: "Overview" > "Phase Noise Meas"

The "Phase Noise" tab of the "Measurement Settings" dialog box contains all functions necessary to configure the measurement range for phase noise measurements, including individual range settings.

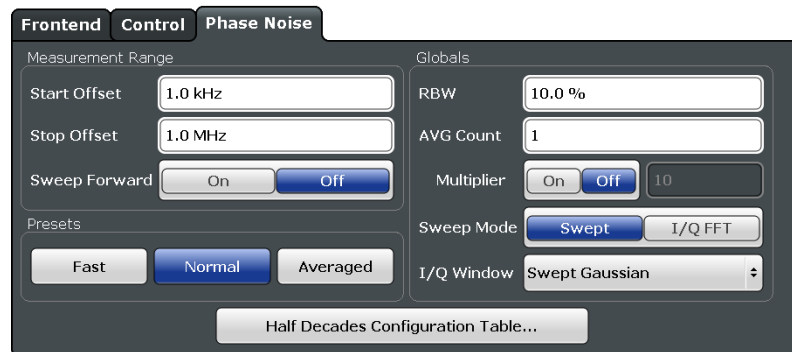

Range Start / Stop.....	40
Sweep Forward.....	41
Presets.....	41
Global RBW.....	41
Global Average Count.....	41
Multiplier.....	42
Global Sweep Mode.....	42
Global I/Q Window.....	42
Half Decades Configuration Table.....	43

Range Start / Stop

Defines the frequency offsets that make up the measurement range.

Note that the maximum offset you can select depends on the hardware you are using.

If a preamplifier is used, make sure the entire frequency range is covered by the preamplifier.

(See "Preamplifier (option B22/B24)" on page 37)

Remote command:

Measurement Range Start

[SENSe:] FREQuency: START on page 96

Measurement Range Stop

[SENSe:] FREQuency: STOP on page 96

Sweep Forward

Selects the sweep direction. Forward and reverse sweep direction are available.

Forward sweep direction performs a measurement that begins at the smallest frequency offset you have defined. The measurement ends after the largest offset has been reached.

Reverse sweep direction performs a measurement that begins at the largest frequency offset you have defined. The measurement ends after the smallest offset has been reached. The reverse sweep is the default sweep direction because the application is able to lock on a drifting carrier frequency in that case.

Remote command:

[SENSe:] SWEep: FORWard on page 99

Presets

Selects predefined measurement settings for each individual half decade that are used for the measurement.

If the measurement settings differ from one of the preset states, the application displays a symbol (🚩) at the label.

"Fast" Fast measurements perform one measurement in each half decade. No averaging takes place.

"Normal" Normal measurements use averaging for some half decades, but with respect to measurement speed.

"Average" Average measurements use averaging for all half decades. However, you have to put up with slower measurement speed.

Remote command:

[SENSe:] SWEep: MODE on page 100

Global RBW

Defines the resolution bandwidth for all half decades globally.

The resulting RBW is a percentage of the start frequency of the corresponding half decade.

If the resulting RBW is not available, the application rounds to the next available bandwidth.

You can also change the global bandwidth with the "RBW Global" softkey in the "Bandwidth" menu.

Remote command:

[SENSe:] LIST: RANGe<range>: BWIDth[: RESolution] on page 97

Global Average Count

Defines the number of measurements that the application uses to calculate averaged results in each half decade.

The range is 1 to 10000.

Remote command:

[\[SENSe:\]LIST:SWEep:COUNT](#) on page 98

Multiplier

Turns a multiplier that changes the average count in each half decade on and off.

If on, you can define a value that multiplies the number of averages currently defined for each half decade by that value.

When you turn it off, the original averages are restored and used again.

Example:

You have three half decades:

- 1st half decade average count: 1
- 2nd half decade average count: 3
- 3rd half decade average count: 5

If you turn the multiplier on and define a value of 5, the average count changes as follows:

- 1st half decade average count: 5
- 2nd half decade average count: 15
- 3rd half decade average count: 25

Remote command:

[\[SENSe:\]LIST:SWEep:COUNT:MULTIplier](#) on page 99

[\[SENSe:\]LIST:SWEep:COUNT:MULTIplier:STATE](#) on page 99

Global Sweep Mode

Selects the analysis mode for all half decades. The sweep mode defines the way the application processes the data.

For more information see [Chapter 4.4, "Sweep Modes"](#), on page 22.

"Normal" Uses spectrum analyzer data for the data analysis.

"I/Q / FFT" Uses I/Q data for the data analysis.

Remote command:

[\[SENSe:\]LIST:BWIDth\[:RESolution\]:TYPE](#) on page 96

Global I/Q Window

Selects the window function for all half decades.

The window function is available for I/Q analysis.

"Blackman Harris" Blackman Harris window.

"Chebychev" Chebychev window.

"Gaussian" Gaussian window.

"Rectangular" Rectangular window.

Remote command:

[\[SENSe:\]LIST:RANGe<range>:IQWindow:TYPE](#) on page 97

Half Decades Configuration Table

Contains all functionality to configure the phase noise measurement range.

"Start"	Shows the offset frequency that the half decade starts with.
"Stop"	Shows the offset frequency that the half decade stops with. Tip: Note that double-clicking on one of the start or stop offset values is an easy way to adjust the measurement range.
"RBW"	Selects resolution bandwidth for the half decade. To avoid invalid measurements and long measurement times, the availability of RBW for each half decade is limited.
"Sweep Mode"	Selects the measurement mode. The measurement mode is the way the application analyzes the data. <ul style="list-style-type: none"> • Swept • I/Q / FFT For more information see Chapter 4.4, "Sweep Modes" , on page 22.
"AVG"	Defines the number of averagings that the application performs before the results for a half decade are displayed.
"Window"	Selects the window type for a half decade. Window functions are available for I/Q measurements.
"Meas Time"	Shows an estimation of how long the measurement of a half decade lasts.

Remote command:

RBW:

[\[SENSe:\]LIST:RANGe<range>:BWIDth\[:RESolution\]](#) on page 97

Sweep Mode

[\[SENSe:\]LIST:RANGe<range>:FILTer:TYPE](#) on page 97

Averages:

[\[SENSe:\]LIST:RANGe<range>:SWEep:COUNT](#) on page 98

Window:

[\[SENSe:\]LIST:RANGe<range>:IQWindow:TYPE](#) on page 97

5.6 Performing Measurements

Access: [SWEEP]

The "Sweep" menu contains all functionality necessary to control and perform phase noise measurements.

Functions to configure the sweep described elsewhere:

- ["Multiplier"](#) on page 42
- ["Global Average Count"](#) on page 41

Continuous Sweep / Run Cont	44
Single Sweep / Run Single	44
Continue Single Sweep	44
Sweep/Average Count	44
Finish Half Decade	44

Continuous Sweep / Run Cont

After triggering, starts the measurement and repeats it continuously until stopped.

While the measurement is running, the "Continuous Sweep" softkey and the [RUN CONT] key are highlighted. The running measurement can be aborted by selecting the highlighted softkey or key again. The results are not deleted until a new measurement is started.

Note: Sequencer. Furthermore, the [RUN CONT] key controls the Sequencer, not individual sweeps. [RUN CONT] starts the Sequencer in continuous mode. For details on the Sequencer, see the R&S FPS User Manual.

Remote command:

`INITiate<n>:CONTInuous` on page 79

Single Sweep / Run Single

While the measurement is running, the "Single Sweep" softkey and the [RUN SINGLE] key are highlighted. The running measurement can be aborted by selecting the highlighted softkey or key again.

Remote command:

`INITiate<n>[:IMMediate]` on page 79

Continue Single Sweep

After triggering, repeats the number of sweeps set in "Sweep Count", without deleting the trace of the last measurement.

While the measurement is running, the "Continue Single Sweep" softkey and the [RUN SINGLE] key are highlighted. The running measurement can be aborted by selecting the highlighted softkey or key again.

Remote command:

`INITiate<n>:CONMeas` on page 78

Sweep/Average Count

Defines the number of sweeps to be performed in the single sweep mode. Values from 0 to 200000 are allowed. If the values 0 or 1 are set, one sweep is performed.

The sweep count is applied to all the traces in all diagrams.

If the trace modes "Average", "Max Hold" or "Min Hold" are set, this value also determines the number of averaging or maximum search procedures.

In continuous sweep mode, if "Sweep Count" = 0 (default), averaging is performed over 10 sweeps. For "Sweep Count" = 1, no averaging, maxhold or minhold operations are performed.

Remote command:

`[SENSe:]SWEep:COUNT` on page 100

Finish Half Decade

Aborts the measurement in the current half decade and continues measuring the subsequent half decade.

Averaged results displayed for a half decade finished prematurely are based on the number of measurements already done.

Remote command:

[SENSe:] SWEEp:FHDecade on page 81

5.7 Configuring In- and Outputs

The "In- / Output" menu contains all functionality necessary to control and perform phase noise measurements.

- [Input Source Configuration](#)..... 45

5.7.1 Input Source Configuration

Access: "Overview" > "Input / Frontend" > "Input Source Config"

The "Radio Frequency" dialog box contains functionality to configure the input source.

Note that the "Radio Frequency (On Off)" button is unavailable in the R&S FPS-K40

[Coupling](#)..... 45

Coupling

Selects the coupling method at the RF input.

AC coupling blocks any DC voltage from the input signal. DC coupling lets DC voltage through.

For more information refer to the data sheet.

Remote command:

INPut<ip>:COUPling on page 144

5.8 Automatic Measurement Configuration

Access: [AUTO SET]

The "Auto Set" menu contains all functionality necessary to determine measurement parameters automatically.

[Adjusting all Determinable Settings Automatically \(Auto All \)](#)..... 45

[Adjusting the Center Frequency Automatically \(Auto Frequency \)](#)..... 46

[Setting the Reference Level Automatically \(Auto Level \)](#)..... 46

Adjusting all Determinable Settings Automatically (Auto All)

Activates all automatic adjustment functions for the current measurement settings.

This includes:

- [Auto Frequency](#)
- [Auto Level](#)

Remote command:

[SENSe:] ADJust:ALL on page 145

Adjusting the Center Frequency Automatically (Auto Frequency)

The R&S FPS adjusts the center frequency automatically.

The optimum center frequency is the frequency with the highest S/N ratio in the frequency span. As this function uses the signal counter, it is intended for use with sinusoidal signals.

At the same time, the optimal reference level is also set (see "[Setting the Reference Level Automatically \(Auto Level \)](#)" on page 46).

Remote command:

`[SENSe:]ADJust:FREQuency` on page 145

Setting the Reference Level Automatically (Auto Level)

Automatically determines a reference level which ensures that no overload occurs at the R&S FPS for the current input data. At the same time, the internal attenuators are adjusted so the signal-to-noise ratio is optimized, while signal compression and clipping are minimized.

To determine the required reference level, a level measurement is performed on the R&S FPS.

If necessary, you can optimize the reference level further. Decrease the attenuation level manually to the lowest possible value before an overload occurs, then decrease the reference level in the same way.

Remote command:

`[SENSe:]ADJust:LEVel` on page 146

6 Analysis

The application provides various means and methods to analyze and evaluate measurement results.

- [Configuring Graphical Result Displays](#).....47
- [Configure Numerical Result Displays](#).....54
- [Using Limit Lines](#).....56
- [Using Markers](#).....63

6.1 Configuring Graphical Result Displays

Access: "Overview" > "Graphical Results"

The "Graphical" tab of the "Results" dialog box and the "Trace" menu contains all functions necessary to set up and configure the graphical phase noise result displays.

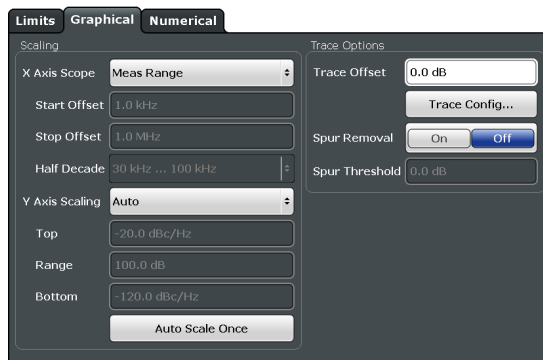

- [Scaling the Diagram](#).....47
- [Configuring Traces](#).....49
- [Trace/Data Ex/Import](#).....51
- [Trace Math](#).....53

6.1.1 Scaling the Diagram

- [X-Axis Scope](#).....47
- [X-Axis Start / Stop](#).....48
- [Half Decade](#).....48
- [Y Axis Scaling](#).....48
- [Top / Range / Bottom](#).....48
- [Auto Scale Once](#).....49

X-Axis Scope

Selects the way the application scales the horizontal axis.

"Half Decade" The horizontal axis shows one half decade that you can select.

"Manual" The horizontal axis shows a detail of the measurement range that you can define freely.

"Meas Range" The horizontal axis shows the complete measurement range.

Remote command:

`DISPlay[:WINDow<n>]:TRACe<t>:X[:SCALe]:SCOPE` on page 116

X-Axis Start / Stop

Defines the start and stop frequency of the horizontal axis.

Note that the displayed frequency range is a detail of the measurement range. Regardless of the displayed frequency range, the application still performs all measurement over the measurement range you have defined.

The range depends on the measurement range. and possible increments correspond to the half decades.

Available for a manual "X Axis Scope".

Remote command:

X-axis start:

`DISPlay[:WINDow<n>]:TRACe<t>:X[:SCALe]:START` on page 116

X-axis stop:

`DISPlay[:WINDow<n>]:TRACe<t>:X[:SCALe]:STOP` on page 117

Half Decade

Selects the half decade that is displayed.

Available if you have selected the half decade "X Axis Scope".

Remote command:

`DISPlay[:WINDow<n>]:TRACe<t>:X[:SCALe]:HDECade` on page 115

Y Axis Scaling

Selects the type of scaling for the vertical axis.

"Auto" Automatically scales the vertical axis.

"Top & Bottom" Allows you to set the values at the top and bottom of the vertical axis.

"Top & Range" Allows to set the value at the top of the vertical axis and its range.

"Bottom & Range" Allows you to set the value at the bottom of the vertical axis and its range.

Remote command:

Automatic scaling:

`DISPlay[:WINDow<n>]:TRACe<t>:Y[:SCALe]:AUTO` on page 118

Manual scaling:

`DISPlay[:WINDow<n>]:TRACe<t>:Y[:SCALe]:MANual` on page 118

Top / Range / Bottom

Define the top and bottom values or the range of the vertical axis.

Top defines the top values of the vertical axis. The unit is dBm/Hz.

Bottom defines the bottom value of the vertical axis. The unit is dBm/Hz.

Range defines the range of the vertical axis. The unit is dB.

The availability of the three fields depends on the type of manual "Y Axis Scaling" you have selected.

Remote command:

Top:

`DISPlay[:WINDow<n>]:TRACe<t>:Y[:SCALe]:RLEVel` on page 119

Range:

`DISPlay[:WINDow<n>]:TRACe<t>:Y[:SCALe]` on page 117

Bottom:

`DISPlay[:WINDow<n>]:TRACe<t>:Y[:SCALe]:RLEVel:LOWer` on page 119

Auto Scale Once

Automatically scales the vertical axis for ideal viewing.

6.1.2 Configuring Traces

Trace Offset.....	49
Trace 1 / Trace 2 / Trace 3 / Trace 4 / Trace 5 / Trace 6	49
Trace Mode	49
Smoothing	50
Spur Removal / Spur Threshold.....	50
Predefined Trace Settings - Quick Config	50
Spectrum Monitor: Raw Trace / Trk Trace (On Off).....	51
Copy Trace	51

Trace Offset

Access: "Overview" > "Graphical Results" > "Graphical" tab

Defines a trace offset in dB.

The trace offset moves the trace vertically by the level you have defined.

The range is from -200 dB to 200 dB.

Remote command:

`DISPlay[:WINDow<n>]:TRACe<t>:Y[:SCALe]:RLEVel:OFFSet` on page 119

Trace 1 / Trace 2 / Trace 3 / Trace 4 / Trace 5 / Trace 6

Selects the corresponding trace for configuration. The currently selected trace is highlighted.

Remote command:

Selected via numeric suffix of: `TRACe<1...6>` commands

`DISPlay[:WINDow<n>][:SUBWindow<w>]:TRACe<t>[:STATe]` on page 115

Trace Mode

Defines the update mode for subsequent traces.

"Clear/ Write" Overwrite mode (default): the trace is overwritten by each sweep.

"Max Hold" The maximum value is determined over several sweeps and displayed. The R&S FPS saves each trace point in the trace memory only if the new value is greater than the previous one.

"Min Hold"	The minimum value is determined from several measurements and displayed. The R&S FPS saves each trace point in the trace memory only if the new value is lower than the previous one.
"Average"	The average is formed over several sweeps.
"View"	The current contents of the trace memory are frozen and displayed.
"Blank"	Removes the selected trace from the display.

Remote command:

`DISPlay[:WINDow<n>]:TRACe<t>:MODE` on page 113

Smoothing

If enabled, the trace is smoothed by the specified value (between 1 % and 50 %). The smoothing value is defined as a percentage of the display width. The larger the smoothing value, the greater the smoothing effect.

Remote command:

`DISPlay[:WINDow<n>][:SUBWindow<w>]:TRACe<t>:SMOothing[:STATe]`
on page 114

`DISPlay[:WINDow<n>][:SUBWindow<w>]:TRACe<t>:SMOothing:APERture`
on page 113

Spur Removal / Spur Threshold

Turns spur removal for all traces on and off and defines the threshold for spur removal.

For more information see [Chapter 4.1, "Spurs and Spur Removal"](#), on page 19.

Note that you can also remove spurs for individual traces in the "Trace Config" dialog box.

Remote command:

Turn spur suppression on and off:

`[SENSe:]SPURs:SUPPpress` on page 122

Set the threshold:

`[SENSe:]SPURs:THReshold` on page 122

Predefined Trace Settings - Quick Config

Commonly required trace settings have been predefined and can be applied very quickly by selecting the appropriate button.

Function	Trace Settings	
Preset All Traces	Trace 1:	Clear Write
		Blank
Set Trace Mode Max Avg Min	Trace 1:	Max Hold
	Trace 2:	Average
	Trace 3:	Min Hold
		Blank
Set Trace Mode Max ClrWrite Min	Trace 1:	Max Hold
	Trace 2:	Clear Write

Function	Trace Settings	
	Trace 3:	Min Hold
		Blank

Spectrum Monitor: Raw Trace / Trk Trace (On Off)

Access: [TRACE] key for selected Spectrum Monitor window

Turns the traces displayed in the Spectrum Monitor result display on and off.

The "Raw Trace (On Off)" softkey controls the yellow trace.

The "Trk Trace (On Off)" softkey controls the blue trace.

Copy Trace

Access: "Overview" > "Analysis" > "Traces" > "Copy Trace"

Or: [TRACE] > "Copy Trace"

Copies trace data to another trace.

The first group of buttons (labeled "Trace 1" to "Trace 6") selects the source trace. The second group of buttons (labeled "Copy to Trace 1" to "Copy to Trace 6") selects the destination.

Remote command:

[TRACe<n>:COPY](#) on page 123

6.1.3 Trace/Data Ex/Import

Access: [TRACE] > "Trace Config" > "Trace / Data Export"

The R&S FPS provides various evaluation methods for the results of the performed measurements. However, you may want to evaluate the data with other, external applications. In this case, you can export the measurement data to a standard ASCII format file (DAT or CSV). You can also import existing trace data from a file, for example as a reference trace (Spectrum application only).



The standard data management functions (e.g. saving or loading instrument settings) that are available for all R&S FPS applications are not described here.

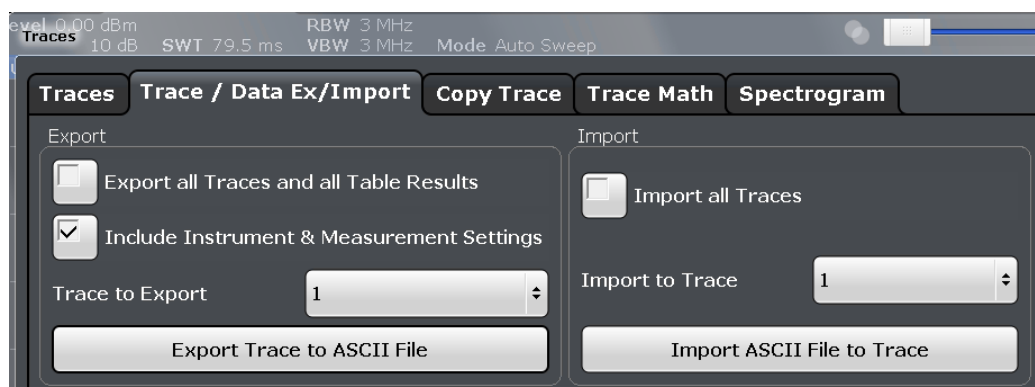

Export all Traces and all Table Results	52
Include Instrument & Measurement Settings	52
Trace to Export	52
Decimal Separator	52
X-Value Distribution.....	52
Export Trace to ASCII File	53
Importing Traces.....	53
L Import All Traces / Import to Trace	53
L Import ASCII File to Trace	53
L File Explorer.....	53

Export all Traces and all Table Results

Selects all displayed traces and result tables (e.g. Result Summary, marker table etc.) in the current application for export to an ASCII file.

Alternatively, you can select one specific trace only for export (see [Trace to Export](#)).

The results are output in the same order as they are displayed on the screen: window by window, trace by trace, and table row by table row.

Remote command:

`FORMat:DEXPort:TRACes` on page 120

Include Instrument & Measurement Settings

Includes additional instrument and measurement settings in the header of the export file for result data.

Remote command:

`FORMat:DEXPort:HEADer` on page 120

Trace to Export

Defines an individual trace to be exported to a file.

This setting is not available if [Export all Traces and all Table Results](#) is selected.

Decimal Separator

Defines the decimal separator for floating-point numerals for the data export/import files. Evaluation programs require different separators in different languages.

Remote command:

`FORMat:DEXPort:DSEParator` on page 120

X-Value Distribution

Defines how the x-values of the trace are determined in the frequency domain.

"Bin-Centered" The full measurement span is divided by the number of sweep points to obtain *bins*. The x-value of the sweep point is defined as the x-value at the center of the bin (bin/2).

"Start/Stop" (Default): The x-value of the first sweep point corresponds to the starting point of the full measurement span. The x-value of the last sweep point corresponds to the end point of the full measurement span. All other sweep points are divided evenly between the first and last points.

Remote command:

`FORMat:DEXPort:XDIStrib` on page 121

Export Trace to ASCII File

Opens a file selection dialog box and saves the selected trace in ASCII format (.dat) to the specified file and directory.

The results are output in the same order as they are displayed on the screen: window by window, trace by trace, and table row by table row.

Remote command:

`MMEMory:STORe<n>:TRACe` on page 122

Importing Traces

Trace data that was stored during a previous measurement can be imported to the Spectrum application, for example as a reference trace.

Import All Traces / Import to Trace ← Importing Traces

If the import file contains more than one trace, you can import several traces at once, overwriting the existing trace data for any active trace in the result display with the same trace number. Data from the import file for currently not active traces is not imported.

Alternatively, you can import a single trace only, which is displayed for the trace number specified in "Import to Trace". This list contains all currently active traces in the result display. If a trace with the specified number exists in the import file, that trace is imported. Otherwise, the first trace in the file is imported (indicated by a message in the status bar).

Remote command:

`FORMat:DIMPort:TRACes` on page 121

Import ASCII File to Trace ← Importing Traces

Loads one trace or all traces from the selected file in the selected ASCII format (.DAT or .CSV) to the currently active result display.

Remote command:

`FORMat:DIMPort:TRACes` on page 121

File Explorer ← Import ASCII File to Trace ← Importing Traces

Opens the Microsoft Windows File Explorer.

Remote command:

not supported

6.1.4 Trace Math

Access: [TRACE] > "Trace Math"

If you have several traces with different modes, for example an average trace and a maximum trace, it may be of interest to compare the results of both traces. In this example, you could analyze the maximum difference between the average and maximum values. To analyze the span of result values, you could subtract the minimum

trace from the maximum trace. For such tasks, the results from several traces can be combined using mathematical functions.

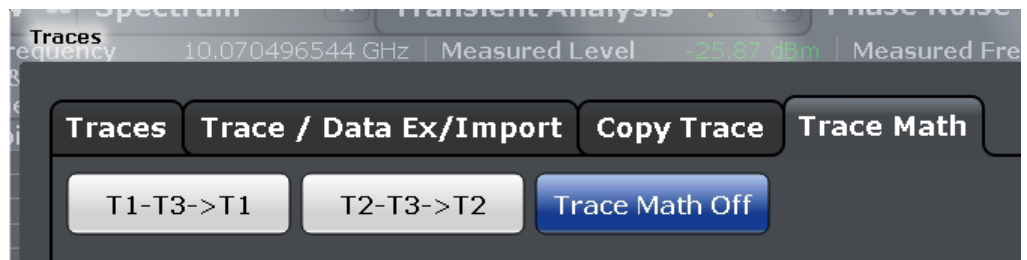

Trace Math Function	54
Trace Math Off	54

Trace Math Function

Defines which trace is subtracted from trace 1. The result is displayed in trace 1.

"T1-T3->T1"	Subtracts trace 3 from trace 1
T2-T3->T2	Subtracts trace 3 from trace 2

To switch off the trace math, use the [Trace Math Off](#) button.

Remote command:

[CALCulate<n>:MATH<t>\[:EXPRession\] \[:DEFine\]](#) on page 112

[CALCulate<n>:MATH<t>:STATe](#) on page 113

Trace Math Off

Deactivates any previously selected trace math functions.

Remote command:

[CALC:MATH:STAT OFF](#), see [CALCulate<n>:MATH<t>:STATe](#) on page 113

6.2 Configure Numerical Result Displays

Access: "Overview" > "Numerical Results"

The "Numerical" tab of the "Results" dialog box contains all functions necessary to set up and configure the numerical phase noise result displays.



6.2.1 Configuring Residual Noise Measurements

Meas Range	55
User Range	55

Meas Range

Turns the integration of the entire measurement range for residual noise calculations on and off.

The range defined here is applied to all traces.

"Meas" The application calculates the residual noise over the entire measurement range.

"Manual" The application calculates the residual noise over a customized range.
The input fields become available to define a customized integration range. The application shows two red lines ("EL1" and "EL2") in the graphical result display to indicate the custom range.

Remote command:

Turn customized range on and off:

[CALCulate<n>:EVALuation\[:STATe\]](#) on page 124

Define start point of custom range:

[CALCulate<n>:EVALuation:START](#) on page 124

Define end point of custom range:

[CALCulate<n>:EVALuation:USER<range>:STOP](#) on page 125

User Range

Defines a custom range for residual noise calculations. You have to assign a user range to a particular trace.

In the default state, user ranges are inactive. "None" is selected in the dropdown menu. If you assign the user range to a trace by selecting one of the traces from the dropdown menu, the input fields next to the trace selection become active. In these fields, you can define a start and stop offset frequency.

Remote command:

Selecting a trace:

[CALCulate<n>:EVALuation:USER<range>:TRACe](#) on page 126

Define start frequency of user range:

[CALCulate<n>:EVALuation:START](#) on page 124

Define stop frequency of user range:

[CALCulate<n>:EVALuation:USER<range>:STOP](#) on page 125

6.2.2 Configuring Spot Noise Measurements

Sort by Frequency	56
On All Decade Edges	56
On User Defined Offsets / Offset Frequency	56

Sort by Frequency

If enabled, the spot noise result table is sorted in ascending order of the offset frequency from the carrier.

On All Decade Edges

Turns the calculation of spot noise on all 10^x offset frequencies on and off.

Remote command:

Turn on and off spot noise calculation on 10^x offset frequencies:

[CALCulate<n>:SNOise<m>:DECades\[:STATe\]](#) on page 129

Querying spot noise results on 10^x offset frequencies:

[CALCulate<n>:SNOise<m>:DECades:X](#) on page 130

[CALCulate<n>:SNOise<m>:DECades:Y](#) on page 130

On User Defined Offsets / Offset Frequency

Turns custom spot noise frequencies on and off.

If on, the "Offset Frequency" input fields become available. You can measure the spot noise for up to five custom offset frequencies. If active, the application adds those spots to the spot noise table.

Remote command:

Turning spot noise marker on and off:

[CALCulate<n>:SNOise<m>:DECades\[:STATe\]](#) on page 129

[CALCulate<n>:SNOise<m>:AOFF](#) on page 129

Positioning spot noise markers:

[CALCulate<n>:SNOise<m>:X](#) on page 131

Querying custom spot noise results:

[CALCulate<n>:SNOise<m>:Y](#) on page 131

6.3 Using Limit Lines

Access: "Overview" > "Limit Analysis"

The "Limits" tab of the "Results" dialog box contains all functions necessary to set up and configure limit lines.

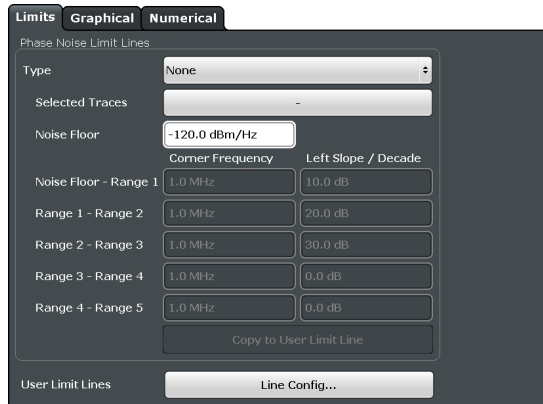

6.3.1 Using Phase Noise Limit Lines

Phase Noise Limit Line.....	57
Selected Traces.....	57
Noise Floor.....	57
Range x - Range y.....	58
Copy to User Limit Line.....	58

Phase Noise Limit Line

Selects the shape of the phase noise limit line.

For more information see [Chapter 4.9, "Using Limit Lines"](#), on page 28.

"None" No limit line.

"Noise floor Limit line defined by the noise floor and x corner frequencies and
and x Ranges" slopes. The application supports up to 5 ranges.

Remote command:

`CALCulate<n>:PNLimit:TYPE` on page 102

Selected Traces

Selects the trace(s) to assign a phase noise limit line to.

For more information see [Chapter 4.9, "Using Limit Lines"](#), on page 28.

Remote command:

`CALCulate<n>:PNLimit:TRACe` on page 102

Noise Floor

Defines the noise floor level in dBm/Hz of the DUT.

For more information see [Chapter 4.9, "Using Limit Lines"](#), on page 28.

Remote command:

`CALCulate<n>:PNLimit:NOISe` on page 101

Range x - Range y

Defines the corner frequencies and slope for a particular segment of phase noise limit lines.

The slope defines the slope of the limit line segment to the left of the corner frequency.

For more information see [Chapter 4.9, "Using Limit Lines"](#), on page 28.

Remote command:

Corner frequencies:

[CALCulate<n>:PNLimit:FC<1 to 5>](#) on page 101

Slope:

[CALCulate<n>:PNLimit:SLOPe<segment>](#) on page 103

Copy to User Limit Line

Creates a new user limit line from the data of a phase noise limit line.

The file is stored in the default folder for user limit lines. You can load and edit the limit line via the "Select Limit Line" dialog box. For more information see ["Select Limit Line"](#) on page 58.

Remote command:

[CALCulate<n>:PNLimit:COPY<k>](#) on page 101

6.3.2 Selecting Standard Limit Lines

Access: "Overview" > "Limit Analysis" > "Line Config"

Select Limit Line.....	58
L Name.....	59
L Unit.....	59
L Compatible.....	59
L Visible.....	59
L Check Traces.....	59
L Comment.....	60
L View Filter.....	60
L New / Edit / Copy To.....	60
L Delete.....	60
L Disable All Lines.....	60

Select Limit Line

The "Select Limit Line" dialog box contains functionality to include standard limit lines in the measurement.

The dialog box consists of a table that shows all available limit lines and their characteristics and a few buttons to manage individual limit lines.

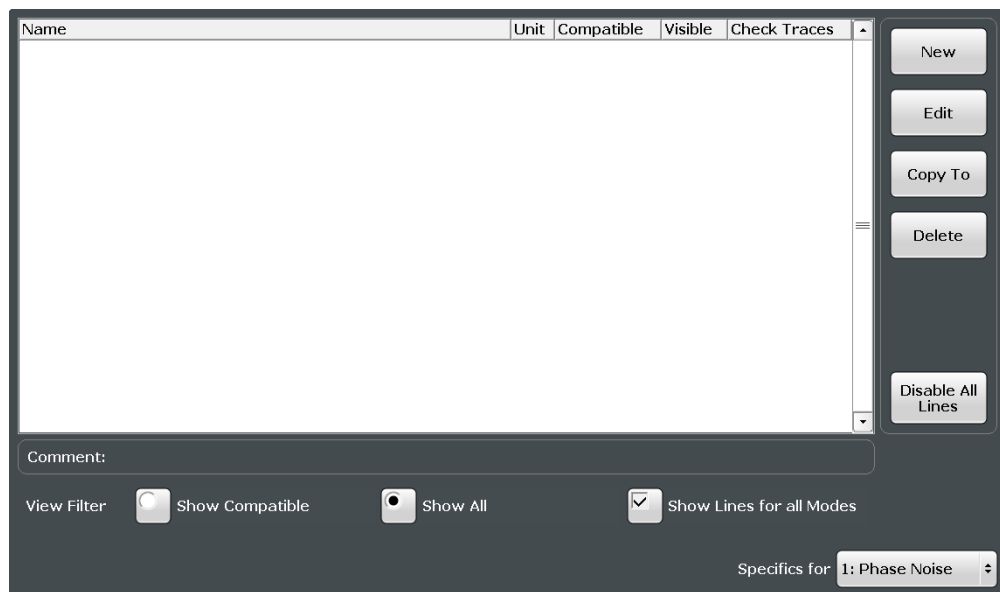
**Name ← Select Limit Line**

Shows the name of the limit line.

Unit ← Select Limit Line

Shows the unit of the limit line.

Compatible ← Select Limit Line

Shows if the limit line is compatible to the current measurement setup or not.

"Yes" You can use the limit line because it is compatible to the current measurement setup.

"No" You cannot use the limit line because it is compatible to the current measurement setup.

Visible ← Select Limit Line

Displays a limit line in the diagram area.

You can display up to eight limit lines at the same time.

Remote command:

Display a limit line:

Lower limit: [CALCulate<n>:LIMit:LOWer:STATe](#) on page 106

Upper limit: [CALCulate<n>:LIMit:UPPer:STATe](#) on page 107

Query all visible limit lines:

[CALCulate<n>:LIMit:ACTive?](#) on page 104

Check Traces ← Select Limit Line

Turns the limit check for a particular trace on and off.

Remote command:

Assign a limit line to a particular trace:

[CALCulate<n>:LIMit:TRACe<t>](#) on page 107

Activate the limit check:

[CALCulate<n>:LIMit:STATe](#) on page 106

Querying limit check results:

[CALCulate<n>:LIMit:FAIL?](#) on page 105

Comment ← Select Limit Line

Shows the comment of the selected limit line. If the limit line has no comment, this field stays empty.

View Filter ← Select Limit Line

Turns filter for the list of limit lines on and off.

By default, the list includes all limit lines that are stored on the R&S FPS.

"Show Compatible" Filters the list of limit lines by compatibility. If on, the list includes only those limit lines that are compatible to the current measurement setup.

"Show Lines For PNoise" Filters the list of limit lines by compatibility to phase noise measurements. If on, the list includes only those limit lines that are compatible to phase noise measurements.

New / Edit / Copy To ← Select Limit Line

All three buttons open the "Edit Limit Line" dialog box to create or edit limit lines.

When you use the "New" button, the dialog box contains no data.

When you use the "Edit" button, the dialog box contains the data of the previously selected limit line.

When you use the "Copy To" button, the dialog box also contains a copy the data of the previously selected limit line.

Remote command:

New:

[CALCulate<n>:LIMit:NAME](#) on page 105

Copy:

[CALCulate<n>:LIMit:COPY](#) on page 104

Delete ← Select Limit Line

Deletes the selected limit line.

Remote command:

[CALCulate<n>:LIMit:DELeTe](#) on page 105

Disable All Lines ← Select Limit Line

Turns all active limit lines off.

6.3.3 Creating and Editing Standard Limit Lines

Access: "Overview" > "Limit Analysis" > "Line Config" > "New" / "Edit" > "Copy To"

Edit Limit Line	61
L Name	61
L Comment	61

L X-Axis.....	61
L Y-Axis.....	62
L Data Points.....	62
L Insert Value.....	62
L Delete Value.....	62
L Shift X.....	62
L Shift Y.....	62
L Save.....	63

Edit Limit Line

The "Edit Limit Line" dialog box contains functionality to describe the shape of a limit line.

Because limit lines have to meet certain conditions for phase noise measurements, the availability of parameters is limited.

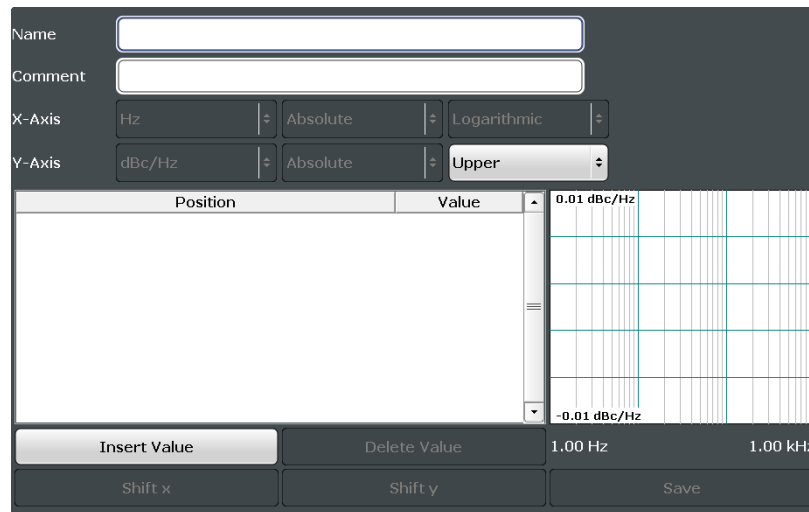

Name ← Edit Limit Line

Defines the name of a limit line.

Remote command:

[CALCulate<n>:LIMit:NAME](#) on page 105

Comment ← Edit Limit Line

Defines a comment for the limit line.

A comment is not mandatory.

Remote command:

[CALCulate<n>:LIMit:COMMENT](#) on page 108

X-Axis ← Edit Limit Line

Defines the characteristics of the horizontal axis.

The characteristics consist of the unit, the scaling and the type of values.

In the Phase Noise application, the unit for the horizontal axis is always Hz. The scaling can either be logarithmic or linear

"Unit" In the Phase Noise application, the unit is always Hz.

- "Scaling" In the Phase Noise application, the scaling of the horizontal axis is always logarithmic.
- "Type of Values" The type of values can be absolute values or relative to the nominal frequency.

Remote command:

Type of values:

[CALCulate<n>:LIMit:LOWer:MODE](#) on page 110

[CALCulate<n>:LIMit:UPPer:MODE](#) on page 110

Y-Axis ← Edit Limit Line

Defines the characteristics of the vertical axis.

The characteristics consist of the unit, the type of values and the usage of the line.

- "Unit" In the Phase Noise application, the unit is always dBc/Hz.
- "Type of Values" In the Phase Noise application, the type of values is always absolute.
- "Line usage" Selects if the limit line is used as an upper or lower limit line.

Data Points ← Edit Limit Line

The data points define the shape of the limit line. A limit line consists of at least 2 data points and a maximum of 200 data points.

A data point is defined by its position in horizontal ("Position" column) and vertical direction ("Value" column). The position of the data points have to be in ascending order.

Remote command:

Horizontal data (position):

[CALCulate<n>:LIMit:CONTrol\[:DATA\]](#) on page 108

Vertical data (value):

Lower limit: [CALCulate<n>:LIMit:LOWer\[:DATA\]](#) on page 109

Upper limit: [CALCulate<n>:LIMit:UPPer\[:DATA\]](#) on page 111

Insert Value ← Edit Limit Line

Insert a new limit line data point below the selected data point.

Delete Value ← Edit Limit Line

Deletes the selected limit line data point.

Shift X ← Edit Limit Line

Shifts each data point horizontally by a particular amount.

Remote command:

[CALCulate<n>:LIMit:CONTrol:SHIFt](#) on page 109

Shift Y ← Edit Limit Line

Shifts each data point vertically by a particular amount.

Remote command:

Lower limit: [CALCulate<n>:LIMit:LOWer:SHIFt](#) on page 110

Upper limit: [CALCulate<n>:LIMit:UPPer:SHIFt](#) on page 111

Save ← Edit Limit Line

Saves the limit line or the changes you have made to a limit line.

6.4 Using Markers

Access (marker position): [MKR] > "Marker Config" > "Markers"

Access (marker settings): [MKR] > "Marker Config" > "Marker Settings"

The "Marker Configuration" dialog box and the "Marker" menu contain all functionality necessary to control markers.

The "Marker Configuration" dialog box consists of two tabs.

The "Markers" tab contains functionality to define characteristics for each marker.



The "Marker Settings" tab contains general marker functionality.



Marker 1 ... Marker x.....	64
Marker Type	64
Reference Marker	64
Assigning the Marker to a Trace	64
Marker Zoom.....	64
All Markers Off	65
Marker Table Display	65
Marker Info	65

Marker 1 ... Marker x

Selects and turns the corresponding marker on and off.

Turning on a marker also opens an input field to define the horizontal position of the marker.

In the "Marker Configuration" dialog box, you can also define the horizontal position of each marker ("x-value").

By default, the first marker you turn on is a normal marker, all others are delta markers.

Remote command:

[CALCulate<n>:MARKer<m>\[:STATe\]](#) on page 138

[CALCulate<n>:DELTAmarker<m>\[:STATe\]](#) on page 140

Marker Type

Toggles the marker type.

The type for marker 1 is always "Normal", the type for delta marker 1 is always "Delta". These types cannot be changed.

Note: If normal marker 1 is the active marker, switching the "Mkr Type" activates an additional delta marker 1. For any other marker, switching the marker type does not activate an additional marker, it only switches the type of the selected marker.

"Normal" A normal marker indicates the absolute value at the defined position in the diagram.

"Delta" A delta marker defines the value of the marker relative to the specified reference marker (marker 1 by default).

Remote command:

[CALCulate<n>:MARKer<m>\[:STATe\]](#) on page 138

[CALCulate<n>:DELTAmarker<m>\[:STATe\]](#) on page 140

Reference Marker

Defines a marker as the reference marker which is used to determine relative analysis results (delta marker values).

Remote command:

[CALCulate<n>:DELTAmarker<m>:MREference](#) on page 139

Assigning the Marker to a Trace

The "Trace" setting assigns the selected marker to an active trace. The trace determines which value the marker shows at the marker position. If the marker was previously assigned to a different trace, the marker remains on the previous frequency or time, but indicates the value of the new trace.

If a trace is turned off, the assigned markers and marker functions are also deactivated.

Remote command:

[CALCulate<n>:MARKer<m>:TRACe](#) on page 138

Marker Zoom

Turns the marker zoom on and off.

The marker zoom magnifies the diagram area around marker 1 by a certain factor.

Turning on the zoom also opens an input field to define the zoom factor.

Remote command:

Turning on the zoom:

[DISPlay\[:WINDow<n>\]:ZOOM\[:STATe\]](#) on page 143

Defining the zoom factor:

[CALCulate<n>:MARKer<m>:FUNction:ZOOM](#) on page 143

All Markers Off

Deactivates all markers in one step.

Remote command:

[CALCulate<n>:MARKer<m>:AOFF](#) on page 137

Marker Table Display

Defines how the marker information is displayed.

"On"	Displays the marker information in a table in a separate area beneath the diagram.
"Off"	No separate marker table is displayed. If Marker Info is active, the marker information is displayed within the diagram area.
"Auto"	(Default) If more than two markers are active, the marker table is displayed automatically. If Marker Info is active, the marker information for up to two markers is displayed in the diagram area.

Remote command:

[DISPlay\[:WINDow<n>\]:MTABLE](#) on page 142

Marker Info

Turns the marker information displayed in the diagram on and off.

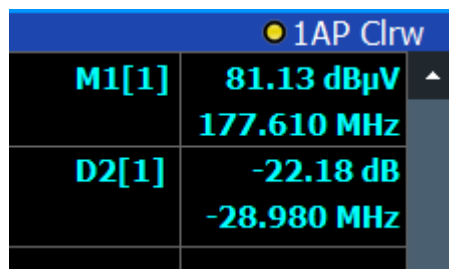

1AP Clrw	
M1[1]	81.13 dBµV 177.610 MHz
D2[1]	-22.18 dB -28.980 MHz

Remote command:

[DISPlay\[:WINDow<n>\]:MINFo\[:STATe\]](#) on page 142

7 How to Configure Phase Noise Measurements

7.1 Performing a Basic Phase Noise Measurement

1. In the Spectrum application, define the center frequency of the DUT.
2. Enter the "Phase Noise" application.
The R&S FPS-K40 starts the measurement with the default configuration. The default configuration defines most settings automatically.
If you need any custom configuration, define them after entering the Phase Noise application.
3. Layout the display as required via the SmartGrid.
4. Open the "Overview" dialog box to configure the measurement.
5. Configure the frontend (frequency, level etc.) via the "Frontend" dialog box.
6. Define the measurement range via the "Phase Noise" dialog box.
7. Turn on frequency and level tracking via the "Control" dialog box.
8. Run a single sweep.
9. Turn on a marker and read out the results.
10. Read out the residual noise over the measurement range.
11. Customize a residual noise range and read out the results.
12. Freeze trace 1 and 2 (trace mode: View).
13. Turn on trace 3 and 4 (trace mode: Clear/Write).
14. Switch the measurement mode to "IQ FFT" in the "Phase Noise" dialog box.
15. Repeat the measurement.

7.2 Customizing the Measurement Range

The application provides several ways to customize. Each method features a different level of details you can define.

1. Open the "Phase Noise" configuration via the "Overview" dialog box or the "Meas Config" softkey menu.

2. Define the frequency offset range you would like to measure in the corresponding fields.
3. Select the "Sweep Type".
 - a) Select sweep types "Fast", "Normal" or "Averaged" for automatic measurement configuration.
For a custom configuration, proceed to set up each measurement parameter separately.
4. Define the "RBW", number of "Averages", sweep "Mode" and "I/Q Window" function.
 - a) Define the parameters globally for all (half) decades covered by the measurement range.
 - b) Define the parameters for each individual (half) decade covered by the measurement range in the "Half Decade Configuration Table".

8 Remote Control Commands for Phase Noise Measurements

The following remote control commands are required to configure and perform phase noise measurements in a remote environment. The R&S FPS must already be configured for remote operation in a network as described in the base unit manual.



Universal functionality

Note that basic tasks that are also performed in the base unit in the same way are not described here. For a description of such tasks, see the R&S FPS user manual.

In particular, this includes:

- Managing settings and results, i.e. storing and loading settings and result data.
- Basic instrument configuration, e.g. checking the system configuration, customizing the screen layout, or configuring networks and remote operation.
- Using the common status registers (specific status registers for pulse measurements are not used).

• Common Suffixes	68
• Introduction	69
• Controlling the Phase Noise Measurement Channel	74
• Performing Measurements	77
• Configuring the Result Display	82
• Configuring the Frontend	89
• Controlling the Measurement	91
• Configuring the Measurement Range	94
• Using Limit Lines	100
• Graphical Display of Phase Noise Results	111
• Configure Numerical Result Displays	123
• Using Markers	137
• Configuring In- and Outputs	143
• Automatic Measurement Configuration	145
• Using the Status Register	146
• Remote Control Example Scripts	152

8.1 Common Suffixes

In the R&S FPS Phase Noise measurements application, the following common suffixes are used in remote commands:

Table 8-1: Common suffixes used in remote commands in the R&S FPS Phase Noise measurements application

Suffix	Value range	Description
<m>	1 to 16	Marker
<n>	1 to 16	Window (in the currently selected channel)
<t>	1 to 4	Trace
	1 to 8	Limit line

8.2 Introduction

Commands are program messages that a controller (e.g. a PC) sends to the instrument or software. They operate its functions ('setting commands' or 'events') and request information ('query commands'). Some commands can only be used in one way, others work in two ways (setting and query). If not indicated otherwise, the commands can be used for settings and queries.

The syntax of a SCPI command consists of a header and, in most cases, one or more parameters. To use a command as a query, you have to append a question mark after the last header element, even if the command contains a parameter.

A header contains one or more keywords, separated by a colon. Header and parameters are separated by a "white space" (ASCII code 0 to 9, 11 to 32 decimal, e.g. blank). If there is more than one parameter for a command, these are separated by a comma from one another.

Only the most important characteristics that you need to know when working with SCPI commands are described here. For a more complete description, refer to the User Manual of the R&S FPS.



Remote command examples

Note that some remote command examples mentioned in this general introduction may not be supported by this particular application.

8.2.1 Conventions used in Descriptions

Note the following conventions used in the remote command descriptions:

- Command usage**
 If not specified otherwise, commands can be used both for setting and for querying parameters.
 If a command can be used for setting or querying only, or if it initiates an event, the usage is stated explicitly.
- Parameter usage**
 If not specified otherwise, a parameter can be used to set a value and it is the result of a query.
 Parameters required only for setting are indicated as **Setting parameters**.

Parameters required only to refine a query are indicated as **Query parameters**. Parameters that are only returned as the result of a query are indicated as **Return values**.

- **Conformity**

Commands that are taken from the SCPI standard are indicated as **SCPI confirmed**. All commands used by the R&S FPS follow the SCPI syntax rules.

- **Asynchronous commands**

A command which does not automatically finish executing before the next command starts executing (overlapping command) is indicated as an **Asynchronous command**.

- **Reset values (*RST)**

Default parameter values that are used directly after resetting the instrument (*RST command) are indicated as ***RST** values, if available.

- **Default unit**

The default unit is used for numeric values if no other unit is provided with the parameter.

- **Manual operation**

If the result of a remote command can also be achieved in manual operation, a link to the description is inserted.

8.2.2 Long and Short Form

The keywords have a long and a short form. You can use either the long or the short form, but no other abbreviations of the keywords.

The short form is emphasized in upper case letters. Note however, that this emphasis only serves the purpose to distinguish the short from the long form in the manual. For the instrument, the case does not matter.

Example:

`SENSe:FREQuency:CENTer` is the same as `SENS:FREQ:CENT`.

8.2.3 Numeric Suffixes

Some keywords have a numeric suffix if the command can be applied to multiple instances of an object. In that case, the suffix selects a particular instance (e.g. a measurement window).

Numeric suffixes are indicated by angular brackets (<n>) next to the keyword.

If you don't quote a suffix for keywords that support one, a 1 is assumed.

Example:

`DISPlay[:WINDow<1...4>]:ZOOM:STATe` enables the zoom in a particular measurement window, selected by the suffix at `WINDow`.

`DISPlay:WINDow4:ZOOM:STATe ON` refers to window 4.

8.2.4 Optional Keywords

Some keywords are optional and are only part of the syntax because of SCPI compliance. You can include them in the header or not.

Note that if an optional keyword has a numeric suffix and you need to use the suffix, you have to include the optional keyword. Otherwise, the suffix of the missing keyword is assumed to be the value 1.

Optional keywords are emphasized with square brackets.

Example:

Without a numeric suffix in the optional keyword:

```
[SENSe:]FREQuency:CENTer is the same as FREQuency:CENTer
```

With a numeric suffix in the optional keyword:

```
DISPlay[:WINDow<1...4>]:ZOOM:STATe
```

DISPlay:ZOOM:STATe ON enables the zoom in window 1 (no suffix).

DISPlay:WINDow4:ZOOM:STATe ON enables the zoom in window 4.

8.2.5 Alternative Keywords

A vertical stroke indicates alternatives for a specific keyword. You can use both keywords to the same effect.

Example:

```
[SENSe:]BANDwidth|BWIDth[:RESolution]
```

In the short form without optional keywords, BAND 1MHZ would have the same effect as BWID 1MHZ.

8.2.6 SCPI Parameters

Many commands feature one or more parameters.

If a command supports more than one parameter, these are separated by a comma.

Example:

```
LAYout:ADD:WINDow Spectrum,LEFT,MTABLE
```

Parameters may have different forms of values.

- [Numeric Values](#).....72
- [Boolean](#).....72
- [Character Data](#).....73
- [Character Strings](#).....73
- [Block Data](#).....73

8.2.6.1 Numeric Values

Numeric values can be entered in any form, i.e. with sign, decimal point or exponent. In case of physical quantities, you can also add the unit. If the unit is missing, the command uses the basic unit.

Example:

With unit: `SENSe:FREQuency:CENTer 1GHZ`

Without unit: `SENSe:FREQuency:CENTer 1E9` would also set a frequency of 1 GHz.

Values exceeding the resolution of the instrument are rounded up or down.

If the number you have entered is not supported (e.g. in case of discrete steps), the command returns an error.

Instead of a number, you can also set numeric values with a text parameter in special cases.

- **MIN/MAX**
Defines the minimum or maximum numeric value that is supported.
- **DEF**
Defines the default value.
- **UP/DOWN**
Increases or decreases the numeric value by one step. The step size depends on the setting. In some cases you can customize the step size with a corresponding command.

Querying numeric values

When you query numeric values, the system returns a number. In case of physical quantities, it applies the basic unit (e.g. Hz in case of frequencies). The number of digits after the decimal point depends on the type of numeric value.

Example:

Setting: `SENSe:FREQuency:CENTer 1GHZ`

Query: `SENSe:FREQuency:CENTer?` would return `1E9`

In some cases, numeric values may be returned as text.

- **INF/NINF**
Infinity or negative infinity. Represents the numeric values `9.9E37` or `-9.9E37`.
- **NAN**
Not a number. Represents the numeric value `9.91E37`. NAN is returned in case of errors.

8.2.6.2 Boolean

Boolean parameters represent two states. The "ON" state (logically true) is represented by "ON" or a numeric value 1. The "OFF" state (logically untrue) is represented by "OFF" or the numeric value 0.

Querying Boolean parameters

When you query Boolean parameters, the system returns either the value 1 ("ON") or the value 0 ("OFF").

Example:

Setting: `DISPlay:WINDow:ZOOM:STATe ON`

Query: `DISPlay:WINDow:ZOOM:STATe?` would return 1

8.2.6.3 Character Data

Character data follows the syntactic rules of keywords. You can enter text using a short or a long form. For more information see [Chapter 8.2.2, "Long and Short Form"](#), on page 70.

Querying text parameters

When you query text parameters, the system returns its short form.

Example:

Setting: `SENSe:BANDwidth:RESolution:TYPE NORMal`

Query: `SENSe:BANDwidth:RESolution:TYPE?` would return `NORM`

8.2.6.4 Character Strings

Strings are alphanumeric characters. They have to be in straight quotation marks. You can use a single quotation mark (') or a double quotation mark (").

Example:

`INSTRument:DELeTe 'Spectrum'`

8.2.6.5 Block Data

Block data is a format which is suitable for the transmission of large amounts of data.

The ASCII character # introduces the data block. The next number indicates how many of the following digits describe the length of the data block. In the example the 4 following digits indicate the length to be 5168 bytes. The data bytes follow. During the transmission of these data bytes all end or other control signs are ignored until all bytes are transmitted. #0 specifies a data block of indefinite length. The use of the indefinite format requires an `NL^END` message to terminate the data block. This format is useful when the length of the transmission is not known or if speed or other considerations prevent segmentation of the data into blocks of definite length.

8.3 Controlling the Phase Noise Measurement Channel

The following commands are necessary to control the measurement channel.

INSTrument:CREate:DUPLicate	74
INSTrument:CREate[:NEW]	74
INSTrument:CREate:REPLace	74
INSTrument:DELeTe	75
INSTrument:LIST?	75
INSTrument:REName	76
INSTrument[:SELeCt]	77
SYSTem:PRESet:CHANnel[:EXEC]	77

INSTrument:CREate:DUPLicate

This command duplicates the currently selected channel, i.e. creates a new channel of the same type and with the identical measurement settings. The name of the new channel is the same as the copied channel, extended by a consecutive number (e.g. "IQAnalyzer" -> "IQAnalyzer 2").

The channel to be duplicated must be selected first using the `INST:SEL` command.

Example:

```
INST:SEL 'IQAnalyzer'
```

```
INST:CRE:DUPL
```

Duplicates the channel named 'IQAnalyzer' and creates a new channel named 'IQAnalyzer2'.

Usage: Event

INSTrument:CREate[:NEW] <ChannelType>, <ChannelName>

This command adds an additional measurement channel. You can configure up to 10 measurement channels at the same time (depending on available memory).

Parameters:

<ChannelType> Channel type of the new channel.
For a list of available channel types see [INSTrument:LIST?](#) on page 75.

<ChannelName> String containing the name of the channel.
Note that you can not assign an existing channel name to a new channel; this will cause an error.

Example:

```
INST:CRE SAN, 'Spectrum 2'
```

Adds an additional spectrum display named "Spectrum 2".

INSTrument:CREate:REPLace <ChannelName1>,<ChannelType>,<ChannelName2>

This command replaces a channel with another one.

Setting parameters:

<ChannelName1> String containing the name of the channel you want to replace.

<ChannelType>	Channel type of the new channel. For a list of available channel types see INSTrument:LIST? on page 75.
<ChannelName2>	String containing the name of the new channel. Note: If the specified name for a new channel already exists, the default name, extended by a sequential number, is used for the new channel (see INSTrument:LIST? on page 75). Channel names can have a maximum of 31 characters, and must be compatible with the Windows conventions for file names. In particular, they must not contain special characters such as ":", "*", "?".
Example:	<code>INST:CRE:REPL 'IQAnalyzer2', IQ, 'IQAnalyzer'</code> Replaces the channel named "IQAnalyzer2" by a new channel of type "IQ Analyzer" named "IQAnalyzer".
Usage:	Setting only

INSTrument:DELeTe <ChannelName>

This command deletes a channel.

If you delete the last channel, the default "Spectrum" channel is activated.

Setting parameters:

<ChannelName>	String containing the name of the channel you want to delete. A channel must exist in order to be able delete it.
---------------	--

Example:	<code>INST:DEL 'IQAnalyzer4'</code> Deletes the channel with the name 'IQAnalyzer4'.
-----------------	---

Usage:	Setting only
---------------	--------------

INSTrument:LIST?

This command queries all active channels. This is useful in order to obtain the names of the existing channels, which are required in order to replace or delete the channels.

Return values:

<ChannelType>, <ChannelName>	For each channel, the command returns the channel type and channel name (see tables below). Tip: to change the channel name, use the INSTrument:REName command.
---------------------------------	--

Example:	<code>INST:LIST?</code> Result for 3 channels: 'ADEM', 'Analog Demod', 'IQ', 'IQ Analyzer', 'IQ', 'IQ Analyzer2'
-----------------	--

Usage:	Query only
---------------	------------

Table 8-2: Available channel types and default channel names in Signal and Spectrum Analyzer mode

Application	<ChannelType> parameter	Default Channel name*)
Spectrum	SANALYZER	Spectrum
1xEV-DO BTS (R&S FPS-K84)	BDO	1xEV-DO BTS
1xEV-DO MS (R&S FPS-K85)	MDO	1xEV-DO MS
3GPP FDD BTS (R&S FPS-K72)	BWCD	3G FDD BTS
3GPP FDD UE (R&S FPS-K73)	MWCD	3G FDD UE
Analog Modulation Analysis (R&S FPS-K7)	ADEM	Analog Demod
cdma2000 BTS (R&S FPS-K82)	BC2K	CDMA2000 BTS
cdma2000 MS (R&S FPS-K83)	MC2K	CDMA2000 MS
GSM (R&S FPS-K10)	GSM	GSM
I/Q Analyzer	IQ	IQ Analyzer
LTE (R&S FPS-K10x)	LTE	LTE
NB-IoT (R&S FPS-K106)	NIOT	NB-IoT
Noise (R&S FPS-K30)	NOISE	Noise
5G NR (R&S FPS-K144)	NR5G	5G NR
Phase Noise (R&S FPS-K40)	PNOISE	Phase Noise
TD-SCDMA BTS (R&S FPS-K76)	BTDS	TD-SCDMA BTS
TD-SCDMA UE (R&S FPS-K77)	MTDS	TD-SCDMA UE
Verizon 5GTF Measurement Application (V5GTF, R&S FPS-K118)	V5GT	V5GT
VSA (R&S FPS-K70)	DDEM	VSA
WLAN (R&S FPS-K91)	WLAN	WLAN
*) If the specified name for a new channel already exists, the default name, extended by a sequential number, is used for the new channel.		

INSTrument:REName <ChannelName1>, <ChannelName2>

This command renames a channel.

Setting parameters:

<ChannelName1> String containing the name of the channel you want to rename.

<ChannelName2> String containing the new channel name.

Note that you cannot assign an existing channel name to a new channel; this will cause an error.

Channel names can have a maximum of 31 characters, and must be compatible with the Windows conventions for file names. In particular, they must not contain special characters such as ":", "*", "?".

Example:	<code>INST:REN 'IQAnalyzer2', 'IQAnalyzer3'</code> Renames the channel with the name 'IQAnalyzer2' to 'IQAnalyzer3'.
Usage:	Setting only

INSTrument[:SElect] <Application>

Selects the measurement application (channel type) for the current channel.

See also `INSTrument:CREate[:NEW]` on page 74.

For a list of available channel types see `INSTrument:LIST?` on page 75.

Parameters:

<Application>	PNOise Phase noise measurements, R&S FPS–K40
---------------	--

SYSTem:PRESet:CHANnel[:EXEC]

This command restores the default instrument settings in the current channel.

Use `INST:SEL` to select the channel.

Example:	<code>INST:SEL 'Spectrum2'</code> Selects the channel for "Spectrum2". <code>SYST:PRESet:CHAN:EXEC</code> Restores the factory default settings to the "Spectrum2"channel.
-----------------	---

Usage: Event

Manual operation: See "Preset Channel" on page 35

8.4 Performing Measurements

The following commands are necessary to perform measurements.



You can also perform a sequence of measurements using the Sequencer (see "Multiple Measurement Channels and Sequencer Function" on page 7).

<code>ABORT</code>	78
<code>CONFigure:REFMeas</code>	78
<code>INITiate<n>:CONMeas</code>	78
<code>INITiate<n>:CONTinuous</code>	79
<code>INITiate<n>[:IMMediate]</code>	79
<code>INITiate:SEQuencer:ABORT</code>	80
<code>INITiate:SEQuencer:IMMediate</code>	80
<code>INITiate:SEQuencer:MODE</code>	80
<code>[SENSe:]SWEEp:FHDecade</code>	81
<code>SYSTem:SEQuencer</code>	81

ABORt

This command aborts the measurement in the current channel and resets the trigger system.

To prevent overlapping execution of the subsequent command before the measurement has been aborted successfully, use the `*OPC?` or `*WAI` command after `ABOR` and before the next command.

For details see the "Remote Basics" chapter in the R&S FPS User Manual.

Note on blocked remote control programs:

If a sequential command cannot be completed, for example because a triggered sweep never receives a trigger, the remote control program will never finish and the remote channel to the R&S FPS is blocked for further commands. In this case, you must interrupt processing on the remote channel first in order to abort the measurement.

To do so, send a "Device Clear" command from the control instrument to the R&S FPS on a parallel channel to clear all currently active remote channels. Depending on the used interface and protocol, send the following commands:

- **Visa:** `viClear()`

Now you can send the `ABORt` command on the remote channel performing the measurement.

Example: `ABOR; :INIT:IMM`
Aborts the current measurement and immediately starts a new one.

Example: `ABOR; *WAI`
`INIT:IMM`
Aborts the current measurement and starts a new one once abortion has been completed.

Usage: Event

CONFigure:REFMeas <arg0>

This command initiates a reference measurement that determines the inherent phase noise of the R&S FPS.

Parameters:
<arg0> ONCE

Example: `CONF:REFM ONCE`
Initiates a reference measurement

Manual operation: See "[Reference Measurement](#)" on page 18

INITiate<n>:CONMeas

This command restarts a (single) measurement that has been stopped (using `ABORt`) or finished in single sweep mode.

The measurement is restarted at the beginning, not where the previous measurement was stopped.

As opposed to `INITiate<n>[:IMMEDIATE]`, this command does not reset traces in maxhold, minhold or average mode. Therefore it can be used to continue measurements using maxhold or averaging functions.

Suffix:

<n> irrelevant

Manual operation: See "[Continue Single Sweep](#)" on page 44

INITiate<n>:CONTInuous <State>

This command controls the sweep mode for an individual channel.

Note that in single sweep mode, you can synchronize to the end of the measurement with `*OPC`, `*OPC?` or `*WAI`. In continuous sweep mode, synchronization to the end of the measurement is not possible. Thus, it is not recommended that you use continuous sweep mode in remote control, as results like trace data or markers are only valid after a single sweep end synchronization.

For details on synchronization see the "Remote Basics" chapter in the R&S FPS User Manual.

Suffix:

<n> irrelevant

Parameters:

<State> ON | OFF | 0 | 1
ON | 1
 Continuous sweep
OFF | 0
 Single sweep
 *RST: 0

Example:

```
INIT:CONT OFF
Switches the sweep mode to single sweep.
INIT:CONT ON
Switches the sweep mode to continuous sweep.
```

Manual operation: See "[Continuous Sweep / Run Cont](#)" on page 44

INITiate<n>[:IMMEDIATE]

This command starts a (single) new measurement.

With sweep count or average count > 0, this means a restart of the corresponding number of measurements. With trace mode MAXHold, MINHold and AVERage, the previous results are reset on restarting the measurement.

You can synchronize to the end of the measurement with `*OPC`, `*OPC?` or `*WAI`.

For details on synchronization see the "Remote Basics" chapter in the R&S FPS User Manual.

Suffix:

<n> irrelevant

Manual operation: See " [Single Sweep / Run Single](#) " on page 44

INITiate:SEQuencer:ABORt

This command stops the currently active sequence of measurements.

You can start a new sequence any time using [INITiate:SEQuencer:IMMEDIATE](#) on page 80.

Usage: Event

INITiate:SEQuencer:IMMEDIATE

This command starts a new sequence of measurements by the Sequencer.

Its effect is similar to the [INITiate<n>\[:IMMEDIATE\]](#) command used for a single measurement.

Before this command can be executed, the Sequencer must be activated (see [SYSTem:SEQuencer](#) on page 81).

Example:

```
SYST:SEQ ON
```

Activates the Sequencer.

```
INIT:SEQ:MODE SING
```

Sets single sequence mode so each active measurement will be performed once.

```
INIT:SEQ:IMM
```

Starts the sequential measurements.

INITiate:SEQuencer:MODE <Mode>

Defines the capture mode for the entire measurement sequence and all measurement groups and channels it contains.

Note: In order to synchronize to the end of a measurement sequence using *OPC, *OPC? or *WAI you must use `SINGLE` Sequence mode.

Parameters:

<Mode>

SINGLE

Each measurement group is started one after the other in the order of definition. All measurement channels in a group are started simultaneously and performed once. After *all* measurements are completed, the next group is started. After the last group, the measurement sequence is finished.

CONTInuous

Each measurement group is started one after the other in the order of definition. All measurement channels in a group are started simultaneously and performed once. After *all* measurements are completed, the next group is started. After the last group, the measurement sequence restarts with the first one and continues until it is stopped explicitly.

*RST: CONTInuous

[SENSe:]SWEep:FHDecade

This command stops the measurement in the current half decade and continues measuring in the subsequent half decade.

Example: SWE:FHD
Aborts the current measurement and continues in the next half decade.

Manual operation: See "[Finish Half Decade](#)" on page 44

SYSTem:SEQuencer <State>

This command turns the Sequencer on and off. The Sequencer must be active before any other Sequencer commands (INIT:SEQ...) are executed, otherwise an error will occur.

A detailed programming example is provided in the "Operating Modes" chapter in the R&S FPS User Manual.

Parameters:

<State> ON | OFF | 0 | 1

ON | 1

The Sequencer is activated and a sequential measurement is started immediately.

OFF | 0

The Sequencer is deactivated. Any running sequential measurements are stopped. Further Sequencer commands (INIT:SEQ...) are not available.

*RST: 0

Example: SYST:SEQ ON
Activates the Sequencer.
INIT:SEQ:MODE SING
Sets single Sequencer mode so each active measurement will be performed once.
INIT:SEQ:IMM
Starts the sequential measurements.
SYST:SEQ OFF

8.5 Configuring the Result Display

The commands required to configure the screen display in a remote environment are described here.

- [General Window Commands](#)..... 82
- [Working with Windows in the Display](#)..... 83

8.5.1 General Window Commands

The following commands are required to configure general window layout, independent of the application.

DISPlay:FORMat	82
DISPlay[:WINDow<n>]:SIZE	82

DISPlay:FORMat <Format>

This command determines which tab is displayed.

Parameters:

<Format>

SPLit

Displays the MultiView tab with an overview of all active channels

SINGle

Displays the measurement channel that was previously focused.

*RST: SING

Example:

DISP:FORM SPL

DISPlay[:WINDow<n>]:SIZE <Size>

This command maximizes the size of the selected result display window *temporarily*. To change the size of several windows on the screen permanently, use the `LAY:SPL` command (see [LAYout:SPLitter](#) on page 85).

Suffix:

<n>

[Window](#)

Parameters:

<Size>

LARGE

Maximizes the selected window to full screen. Other windows are still active in the background.

SMALI

Reduces the size of the selected window to its original size. If more than one measurement window was displayed originally, these are visible again.

*RST: SMALI

Example:

DISP:WIND2:SIZE LARG

8.5.2 Working with Windows in the Display

The following commands are required to change the evaluation type and rearrange the screen layout for a channel as you do using the SmartGrid in manual operation. Since the available evaluation types depend on the selected application, some parameters for the following commands also depend on the selected channel.

Note that the suffix <n> always refers to the window *in the currently selected channel*.

LAYout:ADD[:WINDow]?	83
LAYout:CATalog[:WINDow]?	84
LAYout:IDENtify[:WINDow]?	84
LAYout:REMOve[:WINDow]	85
LAYout:REPLace[:WINDow]	85
LAYout:SPLitter	85
LAYout:WINDow<n>:ADD?	87
LAYout:WINDow<n>:IDENtify?	87
LAYout:WINDow<n>:REMOve	88
LAYout:WINDow<n>:REPLace	88

LAYout:ADD[:WINDow]? <WindowName>, <Direction>, <WindowType>

This command adds a window to the display in the active channel.

This command is always used as a query so that you immediately obtain the name of the new window as a result.

To replace an existing window, use the `LAYout:REPLace[:WINDow]` command.

Query parameters:

<WindowName>	String containing the name of the existing window the new window is inserted next to. By default, the name of a window is the same as its index. To determine the name and index of all active windows, use the <code>LAYout:CATalog[:WINDow]?</code> query.
<Direction>	LEFT RIGHT ABOVE BELOW Direction the new window is added relative to the existing window.
<WindowType>	text value Type of result display (evaluation method) you want to add. See the table below for available parameter values.

Return values:

<NewWindowName>	When adding a new window, the command returns its name (by default the same as its number) as a result.
-----------------	---

Example:

```
LAY:ADD? '1', LEFT, MTAB
```

Result:

```
'2'
```

Adds a new window named '2' with a marker table to the left of window 1.

Usage: Query only

Table 8-3: <WindowType> parameter values for Phase Noise application

Parameter value	Window type
FDRift	Frequency drift
MTABle	Marker table
PNOise	Phase noise diagram
RNOise	Residual noise table
SNOise	Spot noise table
SPECtrum	Spectrum monitor
SPURs	Spur list
SRESults	Sweep result list
STABility	Frequency and level stability indicator

LAYout:CATalog[:WINDow]?

This command queries the name and index of all active windows in the active channel from top left to bottom right. The result is a comma-separated list of values for each window, with the syntax:

<WindowName_1>,<WindowIndex_1>..<WindowName_n>,<WindowIndex_n>

Return values:

<WindowName> string
Name of the window.
In the default state, the name of the window is its index.

<WindowIndex> **numeric value**
Index of the window.

Example:

LAY:CAT?

Result:

'2',2,'1',1

Two windows are displayed, named '2' (at the top or left), and '1' (at the bottom or right).

Usage: Query only

LAYout:IDENtify[:WINDow]? <WindowName>

This command queries the **index** of a particular display window in the active channel.

Note: to query the **name** of a particular window, use the `LAYout:WINDow<n>:IDENtify?` query.

Query parameters:

<WindowName> String containing the name of a window.

Return values:

<WindowIndex> Index number of the window.

Example:

```
LAY:WIND:IDEN? '2'
```

Queries the index of the result display named '2'.

Response:

```
2
```

Usage:

Query only

LAYout:REMove[:WINDow] <WindowName>

This command removes a window from the display in the active channel.

Setting parameters:

<WindowName> String containing the name of the window. In the default state, the name of the window is its index.

Example:

```
LAY:REM '2'
```

Removes the result display in the window named '2'.

Usage:

Setting only

LAYout:REPLace[:WINDow] <WindowName>, <WindowType>

This command replaces the window type (for example from "Diagram" to "Result Summary") of an already existing window in the active channel while keeping its position, index and window name.

To add a new window, use the [LAYout:ADD\[:WINDow\]?](#) command.

Setting parameters:

<WindowName> String containing the name of the existing window. By default, the name of a window is the same as its index. To determine the name and index of all active windows in the active channel, use the [LAYout:CATalog\[:WINDow\]?](#) query.

<WindowType> Type of result display you want to use in the existing window. See [LAYout:ADD\[:WINDow\]?](#) on page 83 for a list of available window types.

Example:

```
LAY:REPL:WIND '1',MTAB
```

Replaces the result display in window 1 with a marker table.

Usage:

Setting only

LAYout:SPLitter <Index1>, <Index2>, <Position>

This command changes the position of a splitter and thus controls the size of the windows on each side of the splitter.

Compared to the [DISPlay\[:WINDow<n>\]:SIZE](#) on page 82 command, the `LAYout:SPLitter` changes the size of all windows to either side of the splitter permanently, it does not just maximize a single window temporarily.

Note that windows must have a certain minimum size. If the position you define conflicts with the minimum size of any of the affected windows, the command will not work, but does not return an error.

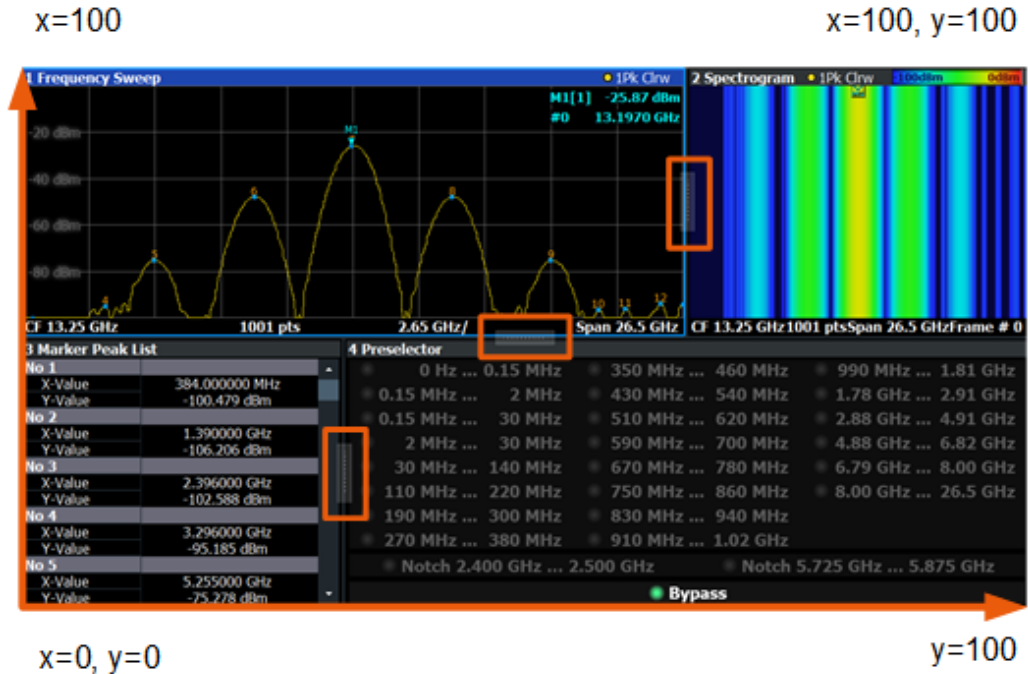

Figure 8-1: SmartGrid coordinates for remote control of the splitters

Setting parameters:

- <Index1> The index of one window the splitter controls.
- <Index2> The index of a window on the other side of the splitter.
- <Position> New vertical or horizontal position of the splitter as a fraction of the screen area (without channel and status bar and softkey menu).
The point of origin ($x = 0$, $y = 0$) is in the lower left corner of the screen. The end point ($x = 100$, $y = 100$) is in the upper right corner of the screen. (See [Figure 8-1](#).)
The direction in which the splitter is moved depends on the screen layout. If the windows are positioned horizontally, the splitter also moves horizontally. If the windows are positioned vertically, the splitter also moves vertically.

Range: 0 to 100

Example:

```
LAY:SPL 1,3,50
```

Moves the splitter between window 1 ('Frequency Sweep') and 3 ('Marker Table') to the center (50%) of the screen, i.e. in the figure above, to the left.

Example: `LAY:SPL 1,4,70`
 Moves the splitter between window 1 ('Frequency Sweep') and 3 ('Marker Peak List') towards the top (70%) of the screen. The following commands have the exact same effect, as any combination of windows above and below the splitter moves the splitter vertically.

`LAY:SPL 3,2,70`
`LAY:SPL 4,1,70`
`LAY:SPL 2,1,70`

Usage: Setting only

LAYout:WINDow<n>:ADD? <Direction>,<WindowType>

This command adds a measurement window to the display. Note that with this command, the suffix <n> determines the existing window next to which the new window is added, as opposed to [LAYout:ADD\[:WINDow\]?](#), for which the existing window is defined by a parameter.

To replace an existing window, use the [LAYout:WINDow<n>:REPLace](#) command.

This command is always used as a query so that you immediately obtain the name of the new window as a result.

Suffix:

<n> [Window](#)

Query parameters:

<Direction> LEFT | RIGHT | ABOVE | BELOW

<WindowType> Type of measurement window you want to add.
 See [LAYout:ADD\[:WINDow\]?](#) on page 83 for a list of available window types.

Return values:

<NewWindowName> When adding a new window, the command returns its name (by default the same as its number) as a result.

Example: `LAY:WIND1:ADD? LEFT,MTAB`
Result:
`'2'`
 Adds a new window named '2' with a marker table to the left of window 1.

Usage: Query only

LAYout:WINDow<n>:IDENTify?

This command queries the **name** of a particular display window (indicated by the <n> suffix) in the active channel.

Note: to query the **index** of a particular window, use the [LAYout:IDENTify\[:WINDow\]?](#) command.

Suffix:	
<n>	Window
Return values:	
<WindowName>	String containing the name of a window. In the default state, the name of the window is its index.
Example:	LAY:WIND2:IDEN? Queries the name of the result display in window 2. Response: '2'
Usage:	Query only

LAYout:WINDow<n>:REMove

This command removes the window specified by the suffix <n> from the display in the active channel.

The result of this command is identical to the [LAYout:REMove\[:WINDow\]](#) command.

Suffix:	
<n>	Window
Example:	LAY:WIND2:REM Removes the result display in window 2.
Usage:	Event

LAYout:WINDow<n>:REPLace <WindowType>

This command changes the window type of an existing window (specified by the suffix <n>) in the active channel.

The effect of this command is identical to the [LAYout:REPLace\[:WINDow\]](#) command.

To add a new window, use the [LAYout:WINDow<n>:ADD?](#) command.

Suffix:	
<n>	Window
Setting parameters:	
<WindowType>	Type of measurement window you want to replace another one with. See LAYout:ADD[:WINDow]? on page 83 for a list of available window types.
Example:	LAY:WIND2:REPL MTAB Replaces the result display in window 2 with a marker table.
Usage:	Setting only

8.6 Configuring the Frontend

The following commands are necessary to configure the frontend settings.

[SENSe:]FREQUency:CENTer.....	89
[SENSe:]POWer:RLEVel.....	89
INPut<ip>:ATTenuation.....	89
INPut<ip>:ATTenuation:AUTO.....	90
INPut:GAIN:STATe.....	90

[SENSe:]FREQUency:CENTer <Frequency>

This command defines the nominal frequency.

Parameters:

<Frequency> Range: 0 to f_{max}
 *RST: f_{max}/2
 Default unit: HZ
 f_{max} is specified in the data sheet. min span is 10 Hz

Example: `FREQ:CENT 100 MHz`
 Defines a nominal frequency of 100 MHz.

Manual operation: See "[Nominal Frequency](#)" on page 36

[SENSe:]POWer:RLEVel <Power>

This command defines the nominal level.

Parameters:

<Power> Range: -200 to 200
 *RST: 0
 Default unit: DBM

Example: `POW:RLEV -20`
 Defines a nominal level of -20 dBm.

INPut<ip>:ATTenuation <Attenuation>

This command defines the total attenuation for RF input.

If you set the attenuation manually, it is no longer coupled to the reference level, but the reference level is coupled to the attenuation. Thus, if the current reference level is not compatible with an attenuation that has been set manually, the command also adjusts the reference level.

Suffix:

<ip> 1 | 2
 irrelevant

Parameters:

<Attenuation> Range: see data sheet
 Increment: 5 dB (with optional electr. attenuator: 1 dB)
 *RST: 10 dB (AUTO is set to ON)
 Default unit: DB

Example:

INP:ATT 30dB
 Defines a 30 dB attenuation and decouples the attenuation from the reference level.

Manual operation: See "[Mechanical Attenuator / Value](#)" on page 36

INPut<ip>:ATTenuation:AUTO <State>

This command couples or decouples the attenuation to the reference level. Thus, when the reference level is changed, the R&S FPS determines the signal level for optimal internal data processing and sets the required attenuation accordingly.

Suffix:

<ip> 1 | 2
 irrelevant

Parameters:

<State> ON | OFF | 0 | 1
 *RST: 1

Example:

INP:ATT:AUTO ON
 Couples the attenuation to the reference level.

Manual operation: See "[Mechanical Attenuator / Value](#)" on page 36

INPut:GAIN:STATe <State>

This command turns the preamplifier on and off.

If activated, the input signal is amplified by 20 dB.

If option R&S FPS-B22 is installed, the preamplifier is only active below 7 GHz.

If option R&S FPS-B24 is installed, the preamplifier is active for all frequencies.

Parameters:

<State> ON | OFF | 0 | 1
OFF | 0
 Switches the function off
ON | 1
 Switches the function on

Example:

INP:GAIN:STAT ON
 Switches on 20 dB preamplification.

Manual operation: See "[Preamplifier \(option B22/B24\)](#)" on page 37

8.7 Controlling the Measurement

The following commands are necessary to control the sequence of the phase noise measurement.

[SENSe:]FREQUENCY:TRACk.....	91
[SENSe:]FREQUENCY:VERify:TOLerance:ABSolute.....	91
[SENSe:]FREQUENCY:VERify:TOLerance[:RELative].....	91
[SENSe:]FREQUENCY:VERify[:STATe].....	92
[SENSe:]IQ:DECimation.....	92
[SENSe:]IQ:DPll.....	92
[SENSe:]IQ:TBW.....	93
[SENSe:]POWER:RLEVel:VERify:TOLerance.....	93
[SENSe:]POWER:RLEVel:VERify[:STATe].....	93
[SENSe:]POWER:TRACk.....	93
[SENSe:]REJect:AM.....	94
[SENSe:]SWEep:SVFailed.....	94

[SENSe:]FREQUENCY:TRACk <State>

This command turns frequency tracking on and off.

Parameters:

<State> ON | OFF | 1 | 0
 *RST: 1

Example: `FREQ:TRAC OFF`
 Turns off frequency tracking.

Manual operation: See "[Frequency Tracking](#)" on page 38

[SENSe:]FREQUENCY:VERify:TOLerance:ABSolute <Frequency>

This command defines an absolute frequency tolerance for frequency verification.

If you define both an absolute and relative tolerance, the application uses the higher tolerance level.

Parameters:

<Frequency> Numeric value in Hz.
 Default unit: HZ

Example: `FREQ:VER:TOL:ABS 100kHz`
 Defines a frequency tolerance range of 100 kHz.

Manual operation: See "[Verify Frequency](#)" on page 38

[SENSe:]FREQUENCY:VERify:TOLerance[:RELative] <Percentage>

This command defines a relative frequency tolerance for frequency verification.

If you define both an absolute and relative tolerance, the application uses the higher tolerance level.

Parameters:

<Percentage> Numeric value in %, relative to the current nominal frequency.
 Range: 1 to 100
 *RST: 10
 Default unit: PCT

Example:

FREQ:VER:TOL:REL 12
 Defines a frequency tolerance of 12% in relation to the nominal frequency.

Manual operation: See "[Verify Frequency](#)" on page 38

[SENSe:]FREQuency:VERify[:STATe] <State>

This command turns frequency verification on and off.

Parameters:

<State> ON | OFF | 1 | 0
 *RST: 1

Example:

FREQ:VER ON
 Turns on frequency verification.

Manual operation: See "[Verify Frequency](#)" on page 38

[SENSe:]IQ:DECimation <State>

This command turns decimation of results on and off.

Parameters:

<State> ON | OFF | 1 | 0
 *RST: 1

Example:

IQ:DEC ON
 Turns on decimation.

Manual operation: See "[Decimation](#)" on page 39

[SENSe:]IQ:DPLL <State>

This command turns the digital PLL on and off.

Parameters:

<State> ON | OFF | 1 | 0

Example:

IQ:DPLL ON
 Turns the digital PLL on.

Manual operation: See "[Digital PLL](#)" on page 39

[SENSe:]IQ:TBW <Bandwidth>

This command defines the maximum tracking bandwidth (sample rate) for all half decades.

Parameters:

<Bandwidth> Range: 60 mHz to 65.28 MHz
 Increment: 10 mHz
 *RST: 60 mHz
 Default unit: HZ

Example:

IQ:TBW 100HZ
 Defines a tracking bandwidth of 100 Hz.

Manual operation: See "[Max Freq Drift](#)" on page 39

[SENSe:]POWer:RLEVel:VERify:TOLerance <Level>

This command defines a relative level tolerance for level verification

Parameters:

<Level> Numeric value in dB, relative to the nominal level.
 *RST: 10 dB
 Default unit: DB

Example:

POW:RLEV:TOL 5
 Defines a level tolerance of 5 dB.

Manual operation: See "[Verify Level](#)" on page 38

[SENSe:]POWer:RLEVel:VERify[:STATe] <State>

This command turns level verification on and off.

Parameters:

<State> ON | OFF | 1 | 0
 *RST: 1

Example:

POW:RLEV:VER ON
 Turns on level verification.

Manual operation: See "[Nominal Level](#)" on page 36
 See "[Verify Level](#)" on page 38
 See "[Level Tracking](#)" on page 39

[SENSe:]POWer:TRACk <State>**Parameters:**

<State>

[SENSe:]REJect:AM <State>

This command turns the suppression of AM noise on and off.

Parameters:

<State> ON | OFF | 1 | 0

Example:

REJ:AM ON
Turns AM noise suppression on.

Manual operation: See ["AM Rejection"](#) on page 39

[SENSe:]SWEep:SVFailed <State>

This command turns repeated tries to start the measurement if signal verification fails on and off.

Parameters:

<State> ON | OFF | AUTO

If on, the application tries to verify the signal once and then aborts the measurement if verification has failed.

*RST: 0

Example:

SWE:SVF ON
Stops the measurement if signal verification has failed.

Manual operation: See ["On Verify Failed"](#) on page 38

8.8 Configuring the Measurement Range

The following commands are necessary to configure the phase noise measurement range.

Table 8-4: <range> suffix assignment

Suffix	Half Decade
1	1 Hz ... 3 Hz
2	3 Hz ... 10 Hz
3	10 Hz ... 30 Hz
4	30 Hz ... 100 Hz
5	100 Hz ... 300 Hz
6	300 Hz ... 1 kHz
7	1 kHz ... 3 kHz
8	3 kHz ... 10 kHz
9	10 kHz ... 30 kHz
10	30 kHz ... 100 kHz

Suffix	Half Decade
11	100 kHz ... 300 kHz
12	300 kHz ... 1 MHz
13	1 MHz ... 3 MHz
14	3 MHz ... 10 MHz
15	10 MHz ... 30 MHz
16	30 MHz ... 100 MHz
17	100 MHz ... 300 MHz
18	300 MHz ... 1 GHz
19	1 GHz ... 3 GHz
20	3 GHz ... 10 GHz
21	30 GHz ... 100 GHz
22	100 GHz ... 300 GHz

[SENSe:]LIST:BWIDth[:RESolution]:RATio.....	95
[SENSe:]FREQuency:STARt.....	96
[SENSe:]FREQuency:STOP.....	96
[SENSe:]LIST:BWIDth[:RESolution]:TYPE.....	96
[SENSe:]LIST:RANGe<range>:BWIDth[:RESolution].....	97
[SENSe:]LIST:RANGe<range>:FILTer:TYPE.....	97
[SENSe:]LIST:RANGe<range>:IQWindow:TYPE.....	97
[SENSe:]LIST:RANGe<range>:SWEep:COUNT.....	98
[SENSe:]LIST:SWEep:COUNT.....	98
[SENSe:]LIST:SWEep:COUNT:MULTiplier.....	99
[SENSe:]LIST:SWEep:COUNT:MULTiplier:STATe.....	99
[SENSe:]SWEep:FORWard.....	99
[SENSe:]SWEep:MODE.....	100
[SENSe:]SWEep:COUNT.....	100

[SENSe:]LIST:BWIDth[:RESolution]:RATio <Ratio>

This command defines the resolution bandwidth over all half decades.

Parameters:

<Ratio>

Numeric value in %.

The resulting RBW is the percentage of the start frequency of each half decade.

If the resulting RBW is not available, the application rounds to the next available bandwidth.

Range: 1 to 100

*RST: 10

Default unit: PCT

Example: `LIST:BWID:RAT 20`
 Defines a RBW of 20% of the start frequency of the corresponding half decade.

[SENSe:]FREQuency:STARt <Frequency>

This command defines the start frequency of the measurement range.

Parameters:

<Frequency> Offset frequencies in half decade steps.
 Range: 1 Hz to 100 GHz
 *RST: 1 kHz
 Default unit: HZ

Example: `FREQ:STAR 10kHz`
 Defines a start frequency of 10 kHz.

Manual operation: See "[Range Start / Stop](#)" on page 40

[SENSe:]FREQuency:STOP <Frequency>

This command defines the stop frequency of the measurement range.

Parameters:

<Frequency> Offset frequencies in half decade steps.
 Range: 3 Hz to 30 GHz
 *RST: 1 MHz
 Default unit: HZ

Example: `FREQ:STOP 10MHz`
 Defines a stop frequency of 10 MHz.

Manual operation: See "[Range Start / Stop](#)" on page 40

[SENSe:]LIST:BWIDth[:RESolution]:TYPE <Mode>

This command selects the sweep mode for all half decades.

Parameters:

<Mode> `NORMal | FFT | IQFFt`
NORMal
 Measurement based on spectrum analyzer data.
FFT
 Measurement based on spectrum analyzer data. Kept for compatibility to R&S FSV.
 *RST: Depends on half decade

Example: `LIST:BWID:RES:TYPE IQFF`
 Selects I/Q analysis mode for all half decades.

Manual operation: See "[Global Sweep Mode](#)" on page 42

[SENSe:]LIST:RANGe<range>:BWIDth[:RESolution] <RBW>

This command defines the resolution bandwidth for a particular half decade.

Suffix:

<range> 1..n
 Selects the half decade.
 For the suffix assignment see [Table 8-4](#).

Parameters:

<RBW> Note that each half decade has a limited range of available bandwidths.
 *RST: Depends on the half decade
 Default unit: HZ

Example:

LIST:RANG9:BWID 100Hz
 Selects a RBW of 100 Hz for the half decade from 1 kHz to 3 kHz.

Manual operation: See "[Global RBW](#)" on page 41
 See "[Half Decades Configuration Table](#)" on page 43

[SENSe:]LIST:RANGe<range>:FILTer:TYPE <Mode>

This command selects the sweep mode for a particular half decade.

Suffix:

<range> 1..n
 Selects the half decade.
 For the suffix assignment see [Table 8-4](#).

Parameters:

<Mode> **NORMAL**
 Measurement based on spectrum analyzer data.
FFT
 Measurement based on spectrum analyzer data. Kept for compatibility to R&S FSV.
IQFFt
 Measurement based on I/Q data.
 *RST: Depends on half decade

Example:

LIST:RANG9:FILT:TYPE FFT
 Selects FFT analysis for the ninth half decade.

Manual operation: See "[Half Decades Configuration Table](#)" on page 43

[SENSe:]LIST:RANGe<range>:IQWindow:TYPE <WindowFunction>

This command selects the window function for a particular half decade.

Window functions are available for I/Q sweep mode.

Suffix:

<range> 1..n
 Selects the half decade.
 For the suffix assignment see [Table 8-4](#).

Parameters:

<WindowFunction> RECTangular | GAUSSian | CHEByshev | BHARris | SWEPT
 *RST: Depends on the half decade

Example:

LIST:RANG:IQW:TYPE BHAR
 Selects the Blackman Harris window function for the first half decade.

Manual operation:

See "[Global I/Q Window](#)" on page 42
 See "[Half Decades Configuration Table](#)" on page 43

[SENSe:]LIST:RANGe<range>:SWEep:COUNT <Measurements>

This command defines the number of measurements included in the averaging for a half decade.

Suffix:

<range> 1..n
 Selects the half decade.
 For the suffix assignment see [Table 8-4](#).

Parameters:

<Measurements> Range: 1 to 10000
 *RST: Depends on the half decade

Example:

LIST:RANG9:SWE:COUN 15
 Includes 15 measurements in the averaging of the ninth half decade.

Manual operation:

See "[Half Decades Configuration Table](#)" on page 43

[SENSe:]LIST:SWEep:COUNT <Averages>

This command defines the number of measurements to be included in the averaging for each and all half decades.

Parameters:

<Averages> Range: 1 to 10000
 *RST: Depends on the half decade.

Example:

LIST:SWE:COUN 20
 Defines 20 averages for all half decades.

Manual operation:

See "[Global Average Count](#)" on page 41

[SENSe:]LIST:SWEep:COUNT:MULTIplier <Multiplier>

This command defines a multiplier that is applied to the average count in each half decade.

Before you can use the command you have to turn on the multiplier with `[SENSe:]LIST:SWEep:COUNT:MULTIplier`.

Parameters:

<Multiplier>

Example:

```
LIST:SWE:COUN:MULT:STAT ON
LIST:SWE:COUN:MULT 5
```

Turns on the multiplier and multiplies the averages by 5.

Manual operation: See "[Multiplier](#)" on page 42

[SENSe:]LIST:SWEep:COUNT:MULTIplier:STATe <State>

This command turns a multiplier that is applied to the average count in each half decade on and off.

Parameters:

<State> ON | OFF | 1 | 0
*RST: 0

Example:

See `[SENSe:]LIST:SWEep:COUNT:MULTIplier:STATe` on page 99.

Manual operation: See "[Multiplier](#)" on page 42

[SENSe:]SWEep:FORWard <State>

This command selects the measurement direction.

Specifies the sweep direction. When switched on the sweep direction is from the start frequency to the stop frequency. When switched off the sweep direction is reversed

Parameters:

<State> **ON | 1**
Measurements in forward direction.
The measurements starts at the smallest offset frequency.
OFF | 0
Measurement in reverse direction.
The measurement starts at the highest offset frequency.
*RST: 0

Example:

```
SWE:FORW ON
```

Selects forward measurements.

Manual operation: See "[Sweep Forward](#)" on page 41

[SENSe:]SWEep:MODE <Mode>

This command selects the type of measurement configuration.

Parameters:

<Mode>

AVERage

Selects a measurement configuration optimized for quality results.

FAST

Selects a measurement configuration optimized for speed.

NORMal

Selects a balanced measurement configuration.

*RST: NORMal

Manual operation: See "[Presets](#)" on page 41

[SENSe:]SWEep:COUNT <SweepCount>

This command defines the number of sweeps that the application uses to average traces.

In continuous sweep mode, the application calculates the moving average over the average count.

In single sweep mode, the application stops the measurement and calculates the average after the average count has been reached.

Parameters:

<SweepCount>

If you set a sweep count of 0 or 1, the R&S FPS performs one single sweep.

Range: 0 to 200000

*RST: 200

Example:

```
SWE:COUN 64
```

Sets the number of sweeps to 64.

```
INIT:CONT OFF
```

Switches to single sweep mode.

```
INIT;*WAI
```

Starts a sweep and waits for its end.

Manual operation: See "[Sweep/Average Count](#)" on page 44

8.9 Using Limit Lines

The following commands are necessary to set up and configure limit lines.

- [Using Phase Noise Limit Lines](#)..... 101
- [Using Standard Limit Lines](#)..... 103
- [Creating and Editing Standard Limit Lines](#)..... 108

8.9.1 Using Phase Noise Limit Lines

CALCulate<n>:PNLimit:COPIY<k>.....	101
CALCulate:PNLimit:FC1 <Frequency>.....	101
CALCulate:PNLimit:FC2 <Frequency>.....	101
CALCulate:PNLimit:FC3 <Frequency>.....	101
CALCulate:PNLimit:FC4 <Frequency>.....	101
CALCulate<n>:PNLimit:FC<1 to 5>.....	101
CALCulate<n>:PNLimit:NOISE.....	101
CALCulate<n>:PNLimit:TRACe.....	102
CALCulate<n>:PNLimit:TYPE.....	102
CALCulate<n>:PNLimit:FAIL?.....	103
CALCulate<n>:PNLimit:SLOPe<segment>.....	103

CALCulate<n>:PNLimit:COPIY<k>

Creates a new user limit line from the data of a phase noise limit line.

Suffix:

<n> 1..n
Number of the limit line the phase noise limit line is copied to. An existing limit line in that slot is overwritten.

<k> 1..n

Example: CALC:PNL:COPIY2
Copies the phase noise limit line to limit line 3.

Manual operation: See "[Copy to User Limit Line](#)" on page 58

CALCulate:PNLimit:FC1 <Frequency>
CALCulate:PNLimit:FC2 <Frequency>
CALCulate:PNLimit:FC3 <Frequency>
CALCulate:PNLimit:FC4 <Frequency>
CALCulate<n>:PNLimit:FC<1 to 5> <CornerFrequency>

This command sets the corner frequency of a phase noise limit line.

Suffix:

<n> 1..n

<1 to 5> 1 to 5

Parameters:

<CornerFrequency> Default unit: Hz

Manual operation: See "[Range x - Range y](#)" on page 58

CALCulate<n>:PNLimit:NOISE <NoiseLevel>

This command defines the noise floor level of the DUT.

The noise floor level is necessary for the calculation of a phase noise limit line.

Suffix:

<n> 1..n

Parameters:

<NoiseLevel> Range: -200 to 200
 *RST: 0
 Default unit: dBm/Hz

Example:

CALC:PNL:NOIS -150
 Defines a noise floor level of 150 dBm/Hz.

Manual operation: See "[Noise Floor](#)" on page 57

CALCulate<n>:PNLimit:TRACe <Trace>...

This command selects the trace to assign a phase noise limit line to.

Suffix:

<n> 1..n

Parameters:

<Trace> Range: 1 to 6
 *RST: -

Example:

CALC:PNL:TRAC 1
 Assigns the phase noise limit line to trace 1.

Manual operation: See "[Selected Traces](#)" on page 57

CALCulate<n>:PNLimit:TYPE <Shape>

This command selects the shape of a phase noise limit line.

Suffix:

<n> 1..n

Parameters:

<Shape> NONE | FC1 | FC2 | FC3 | FC4 | FC5

FC1

Limit line defined by the noise floor and 1 corner frequency.

FC2

Limit line defined by the noise floor and 2 corner frequencies.

FC3

Limit line defined by the noise floor and 3 corner frequencies.

FC4

Limit line defined by the noise floor and 4 corner frequencies.

FC5

Limit line defined by the noise floor and 5 corner frequencies.

NONE

No limit line.

*RST: NONE

Example: `CALC:PNL:TYPE FC2`
Selects a limit line with 2 corner frequencies.

Manual operation: See "[Phase Noise Limit Line](#)" on page 57

CALCulate<n>:PNLimit:FAIL?

This command queries the limit check results for phase noise limit lines.

Suffix:

<n> 1..n

Return values:

<LimitCheck> **1**
Limit check has passed.
0
Limit check has failed.

Example: `CALC:PNL:FAIL?`
Queries the limit check result.

Usage: Query only

CALCulate<n>:PNLimit:SLOPe<segment> <Slope>

This command defines the slope for a phase noise limit line segment.

Suffix:

<n> 1..n

<segment> 1..n
Selects the limit line segment.

Parameters:

<Slope> Level distance from the left border of the limit line segment to the previous one.
*RST: 10
Default unit: dB

Example: `CALC:PNL:SLOP2 20`
Defines a slope of 20 dB for the second limit line segment.

Manual operation: See "[Range x - Range y](#)" on page 58

8.9.2 Using Standard Limit Lines

<code>CALCulate<n>:LIMit:ACTive?</code>	104
<code>CALCulate<n>:LIMit:CLEar[:IMMEDIATE]</code>	104
<code>CALCulate<n>:LIMit:COPY</code>	104
<code>CALCulate<n>:LIMit:DELeTe</code>	105
<code>CALCulate<n>:LIMit:FAIL?</code>	105
<code>CALCulate<n>:LIMit:NAME</code>	105

CALCulate<n>:LIMit:LOWer:STATe.....	106
CALCulate<n>:LIMit:STATe.....	106
CALCulate<n>:LIMit:TRACe<t>.....	107
CALCulate<n>:LIMit:TRACe<t>:CHECK.....	107
CALCulate<n>:LIMit:UPPer:STATe.....	107

CALCulate<n>:LIMit:ACTive?

This command queries the names of *all* active limit lines.

Suffix:

<n> irrelevant

 irrelevant

Return values:

<LimitLines> String containing the names of all active limit lines in alphabetical order.

Example:

CALC:LIM:ACT?

Queries the names of all active limit lines.

Usage:

Query only

Manual operation: See "[Visible](#)" on page 59

CALCulate<n>:LIMit:CLEar[:IMMEDIATE]

This command deletes the result of the current limit check.

The command works on *all* limit lines in *all* measurement windows at the same time.

Suffix:

<n> [Window](#)

 irrelevant

Example:

CALC:LIM:CLE

Deletes the result of the limit check.

CALCulate<n>:LIMit:COPY <Line>

This command copies a limit line.

Suffix:

<n> [Window](#)

 [Limit line](#)

Parameters:

<Line> **1 to 8**
number of the new limit line

<name>

String containing the name of the limit line.

Example: `CALC:LIM1:COPY 2`
 Copies limit line 1 to line 2.
 `CALC:LIM1:COPY 'FM2'`
 Copies limit line 1 to a new line named FM2.

Manual operation: See ["New / Edit / Copy To"](#) on page 60

CALCulate<n>:LIMit:DELeTe

This command deletes a limit line.

Suffix:

<n> [Window](#)

 [Limit line](#)

Manual operation: See ["Delete"](#) on page 60

CALCulate<n>:LIMit:FAIL?

This command queries the result of a limit check in the specified window.

To get a valid result, you have to perform a complete measurement with synchronization to the end of the measurement before reading out the result. This is only possible for single sweep mode.

See also [INITiate<n>:CONTinuous](#) on page 79.

Suffix:

<n> [Window](#)

 [Limit line](#)

Return values:

<Result> **0**
 PASS
 1
 FAIL

Example: `INIT;*WAI`
 Starts a new sweep and waits for its end.
 `CALC2:LIM3:FAIL?`
 Queries the result of the check for limit line 3 in window 2.

Usage: Query only

Manual operation: See ["Check Traces"](#) on page 59

CALCulate<n>:LIMit:NAME <Name>

This command selects a limit line that already exists or defines a name for a new limit line.

Suffix:

<n> [Window](#)

 [Limit line](#)

Parameters:

<Name> String containing the limit line name.
*RST: REM1 to REM8 for lines 1 to 8

Manual operation: See ["New / Edit / Copy To"](#) on page 60
See ["Name"](#) on page 61

CALCulate<n>:LIMit:LOWer:STATe <State>

This command turns a lower limit line on and off.

Before you can use the command, you have to select a limit line with [CALCulate<n>:LIMit:NAME](#) on page 105.

Suffix:

<n> irrelevant

 [Limit line](#)

Parameters:

<State> ON | OFF | 0 | 1
OFF | 0
Switches the function off
ON | 1
Switches the function on

Manual operation: See ["Visible"](#) on page 59

CALCulate<n>:LIMit:STATe <State>

This command turns the limit check for a specific limit line on and off.

To query the limit check result, use [CALCulate<n>:LIMit:FAIL?](#).

Note that a new command exists to activate the limit check and define the trace to be checked in one step (see [CALCulate<n>:LIMit:TRACe<t>:CHECK](#) on page 107).

Suffix:

<n> irrelevant

 [Limit line](#)

Parameters:

<State> ON | OFF | 0 | 1
OFF | 0
Switches the function off
ON | 1
Switches the function on

Example: `CALC:LIM:STAT ON`
Switches on the limit check for limit line 1.

Manual operation: See ["Check Traces"](#) on page 59

CALCulate<n>:LIMit:TRACe<t> <TraceNumber>

This command links a limit line to one or more traces.

Note that this command is maintained for compatibility reasons only. Limit lines no longer need to be assigned to a trace explicitly. The trace to be checked can be defined directly (as a suffix) in the new command to activate the limit check (see [CALCulate<n>:LIMit:TRACe<t>:CHECK](#) on page 107).

Suffix:

<n>	Window
	Limit line
<t>	irrelevant

Example: `CALC:LIM2:TRAC 3`
Assigns limit line 2 to trace 3.

Manual operation: See ["Check Traces"](#) on page 59

CALCulate<n>:LIMit:TRACe<t>:CHECK <State>

This command turns the limit check for a specific trace on and off.

To query the limit check result, use [CALCulate<n>:LIMit:FAIL?](#).

Note that this command replaces the two commands from previous signal and spectrum analyzers (which are still supported, however):

- [CALCulate<n>:LIMit:TRACe<t>](#) on page 107
- [CALCulate<n>:LIMit:STATe](#) on page 106

Suffix:

<n>	Window
	Limit line
<t>	Trace

Parameters:

<State>	ON OFF 0 1
	OFF 0 Switches the function off
	ON 1 Switches the function on

Example: `CALC:LIM3:TRAC2:CHEC ON`
Switches on the limit check for limit line 3 on trace 2.

CALCulate<n>:LIMit:UPPer:STATe <State>

This command turns an upper limit line on and off.

Before you can use the command, you have to select a limit line with `CALCulate<n>:LIMit:NAME` on page 105.

Suffix:

<n> irrelevant

 [Limit line](#)

Parameters:

<State> ON | OFF | 0 | 1

OFF | 0

Switches the function off

ON | 1

Switches the function on

Manual operation: See "[Visible](#)" on page 59

8.9.3 Creating and Editing Standard Limit Lines

<code>CALCulate<n>:LIMit:COMMeNt</code>	108
<code>CALCulate<n>:LIMit:CONTRol[:DATA]</code>	108
<code>CALCulate<n>:LIMit:CONTRol:SHIFt</code>	109
<code>CALCulate<n>:LIMit:LOWer[:DATA]</code>	109
<code>CALCulate<n>:LIMit:LOWer:MODE</code>	110
<code>CALCulate<n>:LIMit:LOWer:SHIFt</code>	110
<code>CALCulate<n>:LIMit:UPPeR:MODE</code>	110
<code>CALCulate<n>:LIMit:UPPeR[:DATA]</code>	111
<code>CALCulate<n>:LIMit:UPPeR:SHIFt</code>	111

`CALCulate<n>:LIMit:COMMeNt` <Comment>

This command defines a comment for a limit line.

Suffix:

<n> irrelevant

 [Limit line](#)

Parameters:

<Comment> String containing the description of the limit line.

Manual operation: See "[Comment](#)" on page 61

`CALCulate<n>:LIMit:CONTRol[:DATA]` <LimitLinePoints>

This command defines the horizontal definition points of a limit line.

Suffix:

<n> irrelevant

 [Limit line](#)

Parameters:

<LimitLinePoints> Variable number of x-axis values.
 Note that the number of horizontal values has to be the same as the number of vertical values set with `CALCulate<n>`:
`LIMit:LOWer[:DATA]` or `CALCulate<n>:LIMit:UPPer[:DATA]`. If not, the R&S FPS either adds missing values or ignores surplus values.
 The unit is Hz.
 *RST: -
 Default unit: HZ

Manual operation: See "Data Points" on page 62

CALCulate<n>:LIMit:CONTrol:SHIFt <Distance>

This command moves a complete limit line horizontally.

Compared to defining an offset, this command actually changes the limit line definition points by the value you define.

Suffix:

<n> irrelevant
 [Limit line](#)

Parameters:

<Distance> Numeric value.
 The unit depends on the scale of the x-axis.
 Default unit: HZ

Manual operation: See "Shift X" on page 62

CALCulate<n>:LIMit:LOWer[:DATA] <LimitLinePoints>

This command defines the vertical definition points of a lower limit line.

Suffix:

<n> irrelevant
 [Limit line](#)

Parameters:

<LimitLinePoints> Variable number of level values.
 Note that the number of vertical values has to be the same as the number of horizontal values set with `CALCulate<n>`:
`LIMit:CONTrol[:DATA]`. If not, the R&S FPS either adds missing values or ignores surplus values.
 *RST: Limit line state is OFF
 Default unit: DBM

Manual operation: See "Data Points" on page 62

CALCulate<n>:LIMit:LOWer:MODE <Mode>

This command selects the vertical limit line scaling.

Suffix:

<n> [Window](#)

 [Limit line](#)

Parameters:

<Mode>

ABSolute

Limit line is defined by absolute physical values.

The unit is variable.

RELative

Limit line is defined by relative values related to the reference level (dB).

*RST: ABSolute

Manual operation: See ["X-Axis"](#) on page 61

CALCulate<n>:LIMit:LOWer:SHIFt <Distance>

This command moves a complete lower limit line vertically.

Compared to defining an offset, this command actually changes the limit line definition points by the value you define.

Suffix:

<n> [Window](#)

 [Limit line](#)

Parameters:

<Distance>

Defines the distance that the limit line moves.

Default unit: DB

Manual operation: See ["Shift Y"](#) on page 62

CALCulate<n>:LIMit:UPPer:MODE <Mode>

This command selects the vertical limit line scaling.

Suffix:

<n> [Window](#)

 [Limit line](#)

Parameters:

<Mode>

ABSolute

Limit line is defined by absolute physical values.

The unit is variable.

RELative

Limit line is defined by relative values related to the reference level (dB).

*RST: ABSolute

Manual operation: See "X-Axis" on page 61

CALCulate<n>:LIMit:UPPer[:DATA] <LimitLinePoints>

This command defines the vertical definition points of an upper limit line.

Suffix:

<n> irrelevant

 [Limit line](#)

Parameters:

<LimitLinePoints> Variable number of level values.
 Note that the number of vertical values has to be the same as the number of horizontal values set with [CALCulate<n>:LIMit:CONTRol\[:DATA\]](#). If not, the R&S FPS either adds missing values or ignores surplus values.

*RST: Limit line state is OFF

Default unit: DBM

Manual operation: See "Data Points" on page 62

CALCulate<n>:LIMit:UPPer:SHIFt <Distance>

This command moves a complete upper limit line vertically.

Compared to defining an offset, this command actually changes the limit line definition points by the value you define.

Suffix:

<n> irrelevant

 [Limit line](#)

Parameters:

<Distance> Defines the distance that the limit line moves.

Manual operation: See "Shift Y" on page 62

8.10 Graphical Display of Phase Noise Results

The following commands are necessary to set up and configure the graphical phase noise result displays.

CALCulate<n>:MATH<t>[:EXPRession][:DEFine]	112
CALCulate<n>:MATH<t>:STATe	113
DISPlay[:WINDow<n>]:TRACe<t>:MODE	113
DISPlay[:WINDow<n>][:SUBWindow<w>]:TRACe<t>:SMOothing:APERture	113
DISPlay[:WINDow<n>][:SUBWindow<w>]:TRACe<t>:SMOothing[:STATe]	114
DISPlay[:WINDow<n>]:TRACe<t>:SMOothing:TYPE	114

DISPlay[:WINDow<n>]:TRACe<t>:SPURs:SUPPResS.....	115
DISPlay[:WINDow<n>][:SUBWIndow<w>]:TRACe<t>[:STATe].....	115
DISPlay[:WINDow<n>]:TRACe<t>:X[:SCALe]:HDECade.....	115
DISPlay[:WINDow<n>]:TRACe<t>:X[:SCALe]:SCOPE.....	116
DISPlay[:WINDow<n>]:TRACe<t>:X[:SCALe]:START.....	116
DISPlay[:WINDow<n>]:TRACe<t>:X[:SCALe]:STOP.....	117
DISPlay[:WINDow<n>]:TRACe<t>:Y[:SCALe].....	117
DISPlay[:WINDow<n>]:TRACe<t>:Y[:SCALe]:AUTO.....	118
DISPlay[:WINDow<n>]:TRACe<t>:Y[:SCALe]:MANual.....	118
DISPlay[:WINDow<n>]:TRACe<t>:Y[:SCALe]:RLEVel.....	119
DISPlay[:WINDow<n>]:TRACe<t>:Y[:SCALe]:RLEVel:LOWer.....	119
DISPlay[:WINDow<n>]:TRACe<t>:Y[:SCALe]:RLEVel:OFFSet.....	119
FORMat:DEXPort:DSEParator.....	120
FORMat:DEXPort:HEADer.....	120
FORMat:DEXPort:TRACes.....	120
FORMat:DIMPort:TRACes.....	121
FORMat:DEXPort:XDIStrib.....	121
MMEMory:LOAD<n>:TRACe.....	122
MMEMory:STORe<n>:TRACe.....	122
[SENSe:]SPURs:SUPPResS.....	122
[SENSe:]SPURs:THReshold.....	122
TRACe<n>:COPY.....	123
TRACe<n>[:DATA].....	123

CALCulate<n>:MATH<t>[:EXPRession][:DEFine] <Expression>

This command selects the mathematical expression for trace mathematics.

Before you can use the command, you have to turn trace mathematics on.

Suffix:

<n>	Window
<t>	irrelevant

Parameters:

<Expression>	(TRACE1-TRACE2) Subtracts trace 2 from trace 1.
	(TRACE1-TRACE3) Subtracts trace 3 from trace 1.
	(TRACE1-TRACE4) Subtracts trace 4 from trace 1.

Example:

```
CALC:MATH:STAT ON
Turns trace mathematics on.
CALC:MATH:EXPR:DEF (TRACE1-TRACE3)
Subtracts trace 3 from trace 1.
```

Manual operation: See " [Trace Math Function](#) " on page 54

CALCulate<n>:MATH<t>:STATe <State>

This command turns the trace mathematics on and off.

Suffix:

<n> [Window](#)

<t> irrelevant

Parameters:

<State> ON | OFF | 0 | 1

OFF | 0

Switches the function off

ON | 1

Switches the function on

Example:

```
CALC:MATH:STAT ON
```

Turns on trace mathematics.

Manual operation: See "[Trace Math Function](#)" on page 54
See "[Trace Math Off](#)" on page 54

DISPlay[:WINDow<n>]:TRACe<t>:MODE <Mode>

This command selects the trace mode. If necessary, the selected trace is also activated.

Suffix:

<n> [Window](#)

<t> [Trace](#)

Example:

```
INIT:CONT OFF
```

Switching to single sweep mode.

```
SWE:COUN 16
```

Sets the number of measurements to 16.

```
DISP:TRAC3:MODE WRIT
```

Selects clear/write mode for trace 3.

```
INIT;*WAI
```

Starts the measurement and waits for the end of the measurement.

Manual operation: See "[Trace Mode](#)" on page 49

DISPlay[:WINDow<n>][:SUBWindow<w>]:TRACe<t>:SMOothing:APERture <Aperture>

This command defines the degree (aperture) of the trace smoothing, if `DISPlay[:WINDow<n>][:SUBWindow<w>]:TRACe<t>:SMOothing[:STATe] TRUE`.

Suffix:

<n> [Window](#)

<w> subwindow

<t> [Trace](#)

Parameters:

<Aperture> Range: 1 to 50
 *RST: 2
 Default unit: PCT

Example: DISP3:TRAC2:SMO:APER 5
 Defines an aperture of 5% for trace 2 in window 3

Manual operation: See "[Smoothing](#)" on page 50

DISPlay[:WINDow<n>][:SUBWindow<w>]:TRACe<t>:SMOothing[:STATe] <State>

This command turns trace smoothing for a particular trace on and off.

If enabled, the trace is smoothed by the value specified using [DISPlay\[:WINDow<n>\]\[:SUBWindow<w>\]:TRACe<t>:SMOothing:APERture](#) on page 113.

Suffix:

<n> [Window](#)

<w> subwindow

<t> [Trace](#)

Parameters:

<State> ON | OFF | 0 | 1
OFF | 0
 Switches the function off
ON | 1
 Switches the function on

Example: DISP3:TRAC2:SMO ON
 Turns on trace smoothing for trace 2 in window 3

Manual operation: See "[Smoothing](#)" on page 50

DISPlay[:WINDow<n>]:TRACe<t>:SMOothing:TYPE <Type>

This command selects the trace smoothing method.

Suffix:

<n> 1..n

<t> 1..n
[Trace](#)

Parameters:

<Type> LINear | LOGarithmic | MEDian
LINear
 Linear smoothing.
LOGarithmic
 Logarithmic smoothing.

MEDian

Median smoothing.

*RST: LIN

Example:

```
DISP:TRAC2:SMO:TYPE LIN
Selects linear smoothing for trace 2.
```

DISPlay[:WINDow<n>]:TRACe<t>:SPURs:SUPPRes <State>

This command turns spur removal for a specific trace on and off.

Suffix:

<n> Window

<t> Trace

Parameters:

<State> ON | OFF | 1 | 0

*RST: OFF

DISPlay[:WINDow<n>][:SUBWindow<w>]:TRACe<t>[:STATe] <State>

This command turns a trace on and off.

The measurement continues in the background.

Suffix:

<n> Window

<w> subwindow
Not supported by all applications

<t> Trace

Example: DISP:TRAC3 ON**Manual operation:** See "[Trace 1 / Trace 2 / Trace 3 / Trace 4 / Trace 5 / Trace 6](#)" on page 49**DISPlay[:WINDow<n>]:TRACe<t>:X[:SCALE]:HDECade <HalfDecade>**

This command selects the half decade to be displayed.

Before you can use the command you have to select the half decade scope for the x-axis with `DISPlay[:WINDow<n>]:TRACe<t>:X[:SCALE]:SCOPE`.**Suffix:**

<n> 1..n

<t> 1..n

Parameters:

<HalfDecade> Start offset frequency of the half decade you want to display. Note that the half decade you want to display has to be part of the current measurement range.

Range: 1 Hz to 100 GHz

*RST: Half decade display is off.

Default unit: HZ

Example:

```
DISP:TRAC:X:HDEC 1KHZ
```

Displays the half decade beginning with 1 kHz.

Manual operation: See "[Half Decade](#)" on page 48

DISPlay[:WINDow<n>]:TRACe<t>:X[:SCALe]:SCOPE <Scope>

This command selects the way the application scales the horizontal axis.

Suffix:

<n> 1..n

<t> 1..n

Parameters:

<Scope> MRANge | HDECades | MANual

MRANge

Shows the complete measurement range.

HDECade

Shows a particular half decade only.

You can select a particular half decade with .

MANual

Shows a custom part of the measurement range.

You can select the start and stop offsets with .

*RST: MRANge

Example:

```
DISP:TRAC:X:SCOP MRAN
```

Shows the complete measurement range on the x-axis.

Manual operation: See "[X-Axis Scope](#)" on page 47

DISPlay[:WINDow<n>]:TRACe<t>:X[:SCALe]:START <StartFrequency>

This command selects the start frequency of the display range.

Before you can use the command you have to select a manual display range for the x-axis with `DISPlay[:WINDow<n>]:TRACe<t>:X[:SCALe]:SCOPE`.

Suffix:

<n> 1..n

<t> 1..n

Parameters:

<StartFrequency> Start offset frequency of a half decade.
 Note that the start offset you want to display has to be part of the current measurement range.
 Range: 100 mHz to 3 GHz
 *RST: Manual display range is OFF
 Default unit: HZ

Example:

DISP:TRAC:X:STAR 100HZ
 Defines 100 Hz as the start of the display range.

Manual operation: See "[X-Axis Start / Stop](#)" on page 48

DISPlay[:WINDow<n>]:TRACe<t>:X[:SCALe]:STOP <StopFrequency>

This command selects the stop frequency of the display range.

Before you can use the command you have to select a manual display range for the x-axis with [DISPlay\[:WINDow<n>\]:TRACe<t>:X\[:SCALe\]:SCOPE](#).

Suffix:

<n> 1..n
 <t> 1..n

Parameters:

<StopFrequency> Stop offset frequency of a half decade.
 Note that the stop offset you want to display has to be part of the current measurement range.
 Range: 300 mHz to 10 GHz
 *RST: Manual display range is OFF
 Default unit: HZ

Example:

DISP:TRAC:X:STOP 3KHZ
 Defines 3 kHz as the end of the display range.

Manual operation: See "[X-Axis Start / Stop](#)" on page 48

DISPlay[:WINDow<n>]:TRACe<t>:Y[:SCALe] <Range>

This command defines the display range of the y-axis.

Suffix:

<n> 1..n
[Window](#)
 <t> irrelevant

Parameters:

<Range> Default unit: dBc / Hz

Manual operation: See "[Top / Range / Bottom](#)" on page 48

DISPlay[:WINDow<n>]:TRACe<t>:Y[:SCALe]:AUTO <Mode>

This command turns automatic scaling of the vertical axis on and off.

Suffix:

<n> 1..n

<t> 1..n

Parameters:

<Mode>

ON

Automatic scaling is on.

OFF

Automatic scaling is off.

ONCE

Automatic scaling is performed once, then turned off again.

*RST: ON

Example:

DISP:WIND2:TRAC:Y:SCAL:AUTO ONCE

Scales the vertical axis once.

Manual operation: See "[Y Axis Scaling](#)" on page 48

DISPlay[:WINDow<n>]:TRACe<t>:Y[:SCALe]:MANual <Mode>

This command selects the type of manual scaling of the vertical axis.

Suffix:

<n> 1..n

<t> 1..n

Parameters:

<Mode>

OFF | TBOTtom | TRANge | BRANge

OFF

Turns manual scaling of the y-axis off.

TBOTtom

Scaling based on the values on the bottom and top of the diagram.

BRANge

Scaling based on the value at the bottom of the diagram and the axis range.

TRANge

Scaling based on the value at the top of the diagram and the axis range.

*RST: ON

Example:

DISP:WIND2:TRAC:Y:SCAL:MAN TRAN

Scaling of the vertical axis based on the top and the range of the axis.

Manual operation: See "[Y Axis Scaling](#)" on page 48

DISPlay[:WINDow<n>]:TRACe<t>:Y[:SCALe]:RLEVel <Reference>

This command defines the reference value or upper border of the diagram area.

Note that you have to select manual y-axis scaling before you can use the command.

Suffix:

<n> 1..n

<t> 1..n

Parameters:

<Reference> Range: -200 to 0
 *RST: -20
 Default unit: DBC/HZ

Example:

DISP:TRAC:Y:RLEV -50
 Defines a reference value of -50 dBc/Hz.

Manual operation: See "[Top / Range / Bottom](#)" on page 48

DISPlay[:WINDow<n>]:TRACe<t>:Y[:SCALe]:RLEVel:LOWer <LowerReference>

This command defines the reference value or upper border of the diagram area.

Note that you have to select manual y-axis scaling before you can use the command.

Suffix:

<n> 1..n

<t> 1..n

Parameters:

<LowerReference> Range: -400 to 1
 *RST: -120
 Default unit: DBC/HZ

Example:

DISP:TRAC:Y:RLEV:LOW -100
 Sets the bottom of the diagram to .100 dBc/Hz.

Manual operation: See "[Top / Range / Bottom](#)" on page 48

DISPlay[:WINDow<n>]:TRACe<t>:Y[:SCALe]:RLEVel:OFFSet <Offset>

This command defines the trace offset.

Suffix:

<n> 1..n

<t> 1..n

Parameters:

<Offset> Range: -200 to 200
 *RST: 0dB
 Default unit: DB

Example: `DISP:TRAC:Y:RLEV:OFFS -10`
 Defines a trace offset of -10 dB.

Manual operation: See ["Trace Offset"](#) on page 49

FORMat:DEXPort:DSEParator <Separator>

This command selects the decimal separator for data exported in ASCII format.

Parameters:

<Separator> POINT | COMMa

COMMa

Uses a comma as decimal separator, e.g. *4,05*.

POINT

Uses a point as decimal separator, e.g. *4.05*.

*RST: *RST has no effect on the decimal separator.
 Default is POINT.

Example: `FORM:DEXP:DSEP POIN`
 Sets the decimal point as separator.

Manual operation: See ["Decimal Separator"](#) on page 52

FORMat:DEXPort:HEADer <State>

If enabled, additional instrument and measurement settings are included in the header of the export file for result data. If disabled, only the pure result data from the selected traces and tables is exported.

Parameters:

<State> ON | OFF | 0 | 1

*RST: 1

Manual operation: See ["Include Instrument & Measurement Settings"](#) on page 52

FORMat:DEXPort:TRACes <Selection>

This command selects the data to be included in a data export file (see [MMEMory:STORe<n>:TRACe](#) on page 122).

Parameters:

<Selection> SINGle | ALL

SINGle

Only a single trace is selected for export, namely the one specified by the [MMEMory:STORe<n>:TRACe](#) command.

ALL

Selects all active traces and result tables (e.g. Result Summary, marker peak list etc.) in the current application for export to an ASCII file.

The <trace> parameter for the `MMEMory:STORe<n>:TRACe` command is ignored.

*RST: SINGLE

Manual operation: See " [Export all Traces and all Table Results](#) " on page 52

FORMat:DIMPort:TRACes <Selection>

This command selects the data to be included in a data import file (see `MMEMory:LOAD<n>:TRACe` on page 122).

Parameters:

<Selection> SINGLE | ALL

SINGLE

Only a single trace is selected for import, namely the one specified by the `MMEMory:LOAD<n>:TRACe` on page 122 command.

ALL

Imports several traces at once, overwriting the existing trace data for any active trace in the result display with the same trace number. Data from the import file for currently not active traces is not imported.

The <trace> parameter for the `MMEMory:LOAD<n>:TRACe` on page 122 command is ignored.

*RST: SINGLE

Manual operation: See " [Import All Traces / Import to Trace](#) " on page 53

See " [Import ASCII File to Trace](#) " on page 53

FORMat:DEXPort:XDIStrib <XDistribution>

Defines how the x-values of the trace are determined in the frequency domain.

Parameters:

<XDistribution> STARTstop | BINCentered

BINCentered

The full measurement span is divided by the number of sweep points to obtain *bins*. The x-value of the sweep point is defined as the x-value at the center of the bin (bin/2).

STARTstop

(Default): The x-value of the first sweep point corresponds to the starting point of the full measurement span. The x-value of the last sweep point corresponds to the end point of the full measurement span. All other sweep points are divided evenly between the first and last points.

Example:

FORM:DEXP:XDIS BINC

Manual operation: See "[X-Value Distribution](#)" on page 52

MMEMory:LOAD<n>:TRACe <Trace>, <FileName>

This command imports trace data from the specified window to an ASCII file.

Suffix:

<n> [Window](#)

Parameters:

<Trace> Number of the trace to be stored
(This parameter is ignored for [FORMat:DImport:TRACes](#) on page 121^{ALL}).

<FileName> String containing the path and name of the import file.

MMEMory:STORe<n>:TRACe <Trace>, <FileName>

This command exports trace data from the specified window to an ASCII file.

Suffix:

<n> [Window](#)

Parameters:

<Trace> Number of the trace to be stored

<FileName> String containing the path and name of the target file.

Example:

```
MMEM:STOR1:TRAC 1, 'C:\TEST.ASC'
Stores trace 1 from window 1 in the file TEST.ASC.
```

Manual operation: See "[Export Trace to ASCII File](#)" on page 53

[SENSe:]SPURs:SUPPReSS <State>

This command turns spur removal for all traces and windows on and off.

Parameters:

<State> ON | OFF | 1 | 0

Example:

```
//Remove spurs
SPUR:SUPP ON
```

Manual operation: See "[Spur Removal / Spur Threshold](#)" on page 50

[SENSe:]SPURs:THReShold <Threshold>

This command defines the level threshold for spur removal.

Parameters:

<Threshold> Range: 0 to 50
*RST: 0
Default unit: DB

Example: `SPUR:THR 10`
Defines a spur threshold of 50 dB.

Manual operation: See "[Spur Removal / Spur Threshold](#)" on page 50

TRACe<n>:COPY <TraceNumber>, <TraceNumber>

This command copies data from one trace to another.

Suffix:
<n> [Window](#)

Parameters:
<TraceNumber> **TRACE1 | TRACE2 | TRACE3 | TRACE4 | TRACE5 | TRACE6**
The first parameter is the destination trace, the second parameter is the source.
(Note the 'e' in the parameter is required!)

Example: `TRAC:COPY TRACE1,TRACE2`
Copies the data from trace 2 to trace 1.

Manual operation: See "[Copy Trace](#)" on page 51

TRACe<n>[:DATA] <Trace>

This command queries the results of the graphical result displays.

Suffix:
<n> 1..n

Parameters:
<Trace> **TRACe1 | TRACe2 | TRACe3 | TRACe4 | TRACe5 | TRACe6**

Example: `TRAC? TRACE1`
Queries the data of trace 1.

Manual operation: See "[Phase Noise Diagram](#)" on page 11
See "[Spectrum Monitor](#)" on page 16

8.11 Configure Numerical Result Displays

The following commands are necessary to configure the numerical phase noise result displays.

- [Configuring Residual Noise Measurements](#)..... 124
- [Reading Out Residual Noise Results](#)..... 126
- [Configuring Spot Noise Measurements](#)..... 129
- [Reading Out the Spur List](#)..... 132
- [Reading Out Measured Values](#)..... 133
- [Reading Out the Sweep Result List](#)..... 134

8.11.1 Configuring Residual Noise Measurements

CALCulate<n>:EVALuation:START.....	124
CALCulate<n>:EVALuation[:STATe].....	124
CALCulate<n>:EVALuation:STOP.....	125
CALCulate<n>:EVALuation:USER<range>:START.....	125
CALCulate<n>:EVALuation:USER<range>:STOP.....	125
CALCulate<n>:EVALuation:USER<range>:TRACe.....	126

CALCulate<n>:EVALuation:START <OffsetFrequency>

This command defines the start point of the residual noise integration range.

Before you can use the command, you have to turn on the measurement range integration with `CALCulate<n>:EVALuation[:STATe]` on page 124.

Suffix:

<n> [Window](#)

<n> 1..n

Parameters:

<OffsetFrequency> The minimum offset is 1 Hz. The maximum offset depends on the hardware you are using.

*RST: 1 kHz

Default unit: HZ

Example:

`CALC:EVAL:STAR 1 kHz`

Defines an start point of 1 kHz for the residual noise range.

Manual operation: See ["Meas Range"](#) on page 55

See ["User Range"](#) on page 55

CALCulate<n>:EVALuation[:STATe] <State>

This command turn integration of the measurement range for residual noise calculation on and off.

Suffix:

<n> [Window](#)

<n> 1..n

Parameters:

<State> **OFF | 0**

Calculates the residual noise over the entire measurement range.

ON | 1

Calculates the residual noise over a customized range.

*RST: 0

Example:

`CALC:EVAL ON`

Uses a customized offset range for residual noise calculation.

Manual operation: See ["Meas Range"](#) on page 55

CALCulate<n>:EVALuation:STOP <OffsetFrequency>

This command defines the end point of the residual noise integration range.

Before you can use the command, you have to turn on the measurement range integration with [CALCulate<n>:EVALuation\[:STATe\]](#) on page 124.

Suffix:

<n> 1..n
[Window](#)

Parameters:

<OffsetFrequency> The minimum offset is 1 Hz. The maximum offset depends on the hardware you are using.

*RST: 1 MHz
Default unit: HZ

Example:

CALC:EVAL:STOP 1 MHz
Defines an end point of 1 MHz for the residual noise range.

CALCulate<n>:EVALuation:USER<range>:START <OffsetFrequency>

Suffix:

<n> 1..n
<range> 1..n

Parameters:

<OffsetFrequency> Default unit: HZ

CALCulate<n>:EVALuation:USER<range>:STOP <OffsetFrequency>

This command defines the end point of a custom residual noise calculation range.

Before you can use the command, you have to assign the user range to a trace with [CALCulate<n>:EVALuation:USER<range>:TRACe](#) on page 126.

Suffix:

<n> 1..n
[Window](#)

<range> 1..n

Parameters:

<OffsetFrequency> The minimum offset is 1 Hz. The maximum offset depends on the hardware you are using.

*RST: 1 MHz
Default unit: HZ

Example:

CALC:EVAL:USER2:STOP 100kHz
Defines an end point of 100 kHz for the second user range.

Manual operation: See "Meas Range" on page 55
See "User Range" on page 55

CALCulate<n>:EVALuation:USER<range>:TRACe <Trace>

This command selects the trace for a custom residual noise calculation range.

Suffix:

<n> 1..n
[Window](#)

<range> 1..n
Selects the user range.

Parameters:

<Trace> NONE | TRACe1 | TRACe2 | TRACe3 | TRACe4 | TRACe5 | TRACe6

TRACE1 ... TRACE6

Trace to assign the user range to.

NONE

Turns a user range off.

Example: CALC:EVAL:USER2:TRAC TRACE2
Assigns the second user range to trace 2.

Manual operation: See "User Range" on page 55

8.11.2 Reading Out Residual Noise Results

FETCh:PNOise<t>:IPN?	126
FETCh:PNOise<t>:RFM?	127
FETCh:PNOise<t>:RMS?	127
FETCh:PNOise<t>:RPM?	127
FETCh:PNOise<t>:USER<range>:IPN?	127
FETCh:PNOise<t>:USER<range>:RFM?	128
FETCh:PNOise<t>:USER<range>:RMS?	128
FETCh:PNOise<t>:USER<range>:RPM?	128

FETCh:PNOise<t>:IPN?

This command queries the Integrated Phase Noise for the first trace.

Suffix:

<t> 1..n

Example: FETC:PNO2:IPN?
Queries the Integrated Phase Noise for the first trace in the diagram.

Usage: Query only

FETCH:PNOise<t>:RFM?

This command queries the residual FM for the first trace.

Suffix:

<t> 1..n
 Trace

Example:

FETCH:PNO2:RFM?
Queries the residual FM for the first trace in the diagram.

Usage:

Query only

FETCH:PNOise<t>:RMS?

This command queries the residual RMS jitter for the first trace.

Suffix:

<t> 1..n
 Trace

Example:

FETCH:PNO2:RMS?
Queries the RMS jitter for the first trace in the diagram.

Usage:

Query only

FETCH:PNOise<t>:RPM?

This command queries the residual PM for a particular user range.

The trace that is queried depends on [CALCulate<n>:EVALuation:USER<range>:TRACE](#).

Suffix:

<t> 1..n
 Trace

<range>

1...3
Selects the user range.

Example:

FETCH:PNO:USER2:RPM?
Queries the residual PM for user range 2.

Usage:

Query only

FETCH:PNOise<t>:USER<range>:IPN?

This command queries the Integrated Phase Noise for a particular user range.

The trace that is queried depends on [CALCulate<n>:EVALuation:USER<range>:TRACE](#).

Suffix:

<t> 1..n
 Trace

<range> 1..n
Selects the user range.

Example: FETC:PNO:USER2:IPN?
Queries the Integrated Phase Noise for user range 2.

Usage: Query only

FETCh:PNOise<t>:USER<range>:RFM?

This command queries the residual FM for a particular user range.

The trace that is queried depends on [CALCulate<n>:EVALuation:USER<range>:TRACe](#).

Suffix:

<t> 1..n
[Trace](#)

<range> 1..n
Selects the user range.

Example: FETC:PNO:USER2:RFM?
Queries the residual FM for user range 2.

Usage: Query only

Manual operation: See "[Residual Noise](#)" on page 12

FETCh:PNOise<t>:USER<range>:RMS?

This command queries the residual RMS jitter for a particular user range.

The trace that is queried depends on [CALCulate<n>:EVALuation:USER<range>:TRACe](#).

Suffix:

<t> 1..n
[Trace](#)

<range> 1..n
Selects the user range.

Example: FETC:PNO:USER2:RMS?
Queries the RMS jitter for user range 2.

Usage: Query only

Manual operation: See "[Residual Noise](#)" on page 12

FETCh:PNOise<t>:USER<range>:RPM?

This command queries the residual PM for the first trace.

Suffix:	
<t>	1..n Trace
<range>	1..n
Example:	FETC:PNO:RPM? Queries the residual PM for the first trace of the diagram.
Usage:	Query only
Manual operation:	See "Residual Noise" on page 12

8.11.3 Configuring Spot Noise Measurements

CALCulate<n>:SNOise<m>:AOFF.....	129
CALCulate<n>:SNOise<m>:DECades[:STATe].....	129
CALCulate<n>:SNOise<m>:DECades:X.....	130
CALCulate<n>:SNOise<m>:DECades:Y.....	130
CALCulate<n>:SNOise<m>[:STATe].....	131
CALCulate<n>:SNOise<m>:X.....	131
CALCulate<n>:SNOise<m>:Y.....	131
DISPlay[:WINDow<n>]:TRACe<t>:SELect.....	132

CALCulate<n>:SNOise<m>:AOFF

This command turns all spot noise markers off (custom and 10^x markers).

Suffix:	
<n>	1..n Window
<m>	1..n
Example:	CALC:SNO:AOFF Turns all spot noise markers off.
Manual operation:	See "On User Defined Offsets / Offset Frequency" on page 56

CALCulate<n>:SNOise<m>:DECades[:STATe] <State>

This command turns the spot noise calculation on every 10^x offset frequency on and off.

Suffix:	
<n>	1..n Window
<m>	1..n
Parameters:	
<State>	ON OFF 1 0 *RST: 1

- Example:** `CALC:SNO:DEC ON`
Turns the spot noise calculation for each decade start on.
- Manual operation:** See ["On All Decade Edges"](#) on page 56
See ["On User Defined Offsets / Offset Frequency"](#) on page 56

CALCulate<n>:SNOise<m>:DECades:X

This command queries the horizontal position of the 10^x offset frequency spot noise markers.

Suffix:

<n> 1..n
[Window](#)

<m> 1..n

Return values:

<OffsetFrequency> List of offset frequencies, one for each 10^x spot noise marker. The number of return values depends on the measurement range.
Default unit: Hz

Example: `CALC:SNO:DEC:X?`
Return values, e.g.:
1000,10000,100000,1000000

Manual operation: See ["Spot Noise"](#) on page 13
See ["On All Decade Edges"](#) on page 56

CALCulate<n>:SNOise<m>:DECades:Y

This command queries the vertical position of the 10^x offset frequency spot noise markers.

Suffix:

<n> 1..n
[Window](#)

<m> 1..n

Return values:

<Level> List of level values, one for each 10^x spot noise marker. The number of return values depends on the measurement range.
Default unit: dBc/Hz

Example: `CALC:SNO:DEC:Y?`
Return values, e.g.:
-152.560974121094,-136.443389892578,
-145.932891845703,-152.560974121094

Manual operation: See ["Spot Noise"](#) on page 13
See ["On All Decade Edges"](#) on page 56

CALCulate<n>:SNOise<m>[:STATe] <State>

This command turns a custom spot noise marker on and off.

Suffix:

<n> 1..n
Window

<m> 1..n
Selects the spot noise marker.

Parameters:

<State> ON | OFF | 1 | 0
*RST: All 1

Example: CALC:SNO3:STATE ON
Turns spot noise marker 3 on.

CALCulate<n>:SNOise<m>:X <OffsetFrequency>

This command defines the horizontal position of a custom spot noise marker.

Suffix:

<n> 1..n
Window

<m> 1..n
Selects the spot noise marker.

Parameters:

<OffsetFrequency> The minimum offset is 1 Hz. The maximum offset depends on the hardware you are using.
The default value varies for each of the five spot noise markers. For marker 1 it is 1 kHz, for marker 2 it is 10 kHz, for marker 3 it is 100 kHz, for marker 4 it is 1 MHz and for marker 5 it is 10 MHz
Default unit: HZ

Example: CALC:SNO3:X 2MHz
Positions the third custom spot noise marker to an offset frequency of 2 MHz.

Manual operation: See "[On User Defined Offsets / Offset Frequency](#)" on page 56

CALCulate<n>:SNOise<m>:Y <Level>

This command queries the vertical position of a custom spot noise marker.

Suffix:

<n> 1..n
Window

<m> 1..n
Selects the spot noise marker

Parameters:

<Level> Phase noise level at the marker position.
Default unit: dBc/Hz

Example:

CALC:SNO3:Y?
Queries the level of the third custom spot noise marker.

Manual operation:

See "Spot Noise" on page 13
See "On User Defined Offsets / Offset Frequency" on page 56

DISPlay[:WINDow<n>]:TRACe<t>:SElect <Trace>

This command selects the trace for which spot noise results are calculated.
A trace can only be selected if it has been turned on ("Trace Mode" ≠ Blank).

Suffix:

<n> 1..n
irrelevant

<t> 1..n
irrelevant

Parameters:

<Trace> Number of the trace you want to select.
Range: 1 to 6
*RST: 1

Example:

DISP:TRAC:SEL 2
Selects trace number 2.

Manual operation:

See "Spot Noise" on page 13

8.11.4 Reading Out the Spur List

FETCh:PNOise<t>:SPURs?.....	132
FETCh:PNOise<t>:SPURs:DISCReTe?.....	133
FETCh:PNOise<t>:SPURs:RANDOm?.....	133

FETCh:PNOise<t>:SPURs?

This command queries the location and level of all spurs that have been detected.

Suffix:

<t> 1..n

Return values:

<Spurs> Returns two values (frequency and level) for each each spur that has been detected.

Example: FETC:PNO:SPUR?
would return, e.g.
1999.232666,-0.639974,6494.312500,-0.760579,
19992.324219,-0.639974

Usage: Query only

Manual operation: See "[Spur List](#)" on page 14

FETCh:PNOise<t>:SPURs:DISCcrete?

This command queries the Discrete Jitter result.

Suffix:
<t> 1..n

Return values:
<Jitter>

Example: FETC:PNO:SPUR:DISC?
would return, e.g.
2.3e-08

Usage: Query only

Manual operation: See "[Spur List](#)" on page 14

FETCh:PNOise<t>:SPURs:RANDom?

Suffix:
<t> 1..n

Return values:
<Jitter>

Usage: Query only

Manual operation: See "[Spur List](#)" on page 14

8.11.5 Reading Out Measured Values

[FETCh:PNOise<t>:MEASured:FREQUency?](#)..... 133

[FETCh:PNOise<t>:MEASured:LEVel?](#)..... 134

FETCh:PNOise<t>:MEASured:FREQUency?

This command queries the carrier frequency that has been actually measured.

The measured frequency is shown in the channel bar.

Suffix:
<t> 1..n

Return values:	
<Frequency>	Frequency in Hz.
Example:	FETC:PNO:MEAS:FREQ? Queries the measured frequency.
Usage:	Query only

FETCh:PNOise<t>:MEASured:LEVel?

This command queries the level of the DUT that has been actually measured.
The measured level is shown in the channel bar.

Suffix:	
<t>	1..n
Return values:	
<Level>	Level in dBm.
Example:	FETC:PNO:MEAS:LEV? Queries the measured level.
Usage:	Query only

8.11.6 Reading Out the Sweep Result List

FETCh:PNOise<t>:SWEep:AVG?.....	134
FETCh:PNOise<t>:SWEep:FDRift?.....	135
FETCh:PNOise<t>:SWEep:LDRift?.....	135
FETCh:PNOise<t>:SWEep:MDRift?.....	135
FETCh:PNOise<t>:SWEep:SRATe?.....	136
FETCh:PNOise<t>:SWEep:START?.....	136
FETCh:PNOise<t>:SWEep:STOP?.....	137

FETCh:PNOise<t>:SWEep:AVG?

This command queries the number of measurements that have been performed in each half decade.

Suffix:	
<t>	1..n
Return values:	
<Measurements>	Number of measurements as displayed in the Sweep Result List. The command returns one value for each half decade as a comma separated list.
Example:	FETC:PNO:SWE:AVG? would return, e.g.: 10,10,10,10,10
Usage:	Query only

Manual operation: See ["Sweep Result List"](#) on page 15

FETCh:PNOise<t>:SWEep:FDRift?

This command queries the frequency drift in each half decade.

Suffix:

<t> 1..n

Return values:

<Frequency> Frequency drift as displayed in the Sweep Result List.
The command returns one value for each half decade as a comma separated list.

Default unit: Hz

Example:

FETC:PNO:SWE:FDR?

would return, e.g.:

-203.565049124882, -198.254803592339,
-179.608235809952, -126.506989398971,
-95.0386250484735

Usage: Query only

Manual operation: See ["Sweep Result List"](#) on page 15

FETCh:PNOise<t>:SWEep:LDRift?

This command queries the level drift in each half decade.

Suffix:

<t> 1..n

Return values:

<Level> Level drift as displayed in the Sweep Result List.
The command returns one value for each half decade as a comma separated list.

Default unit: dB

Example:

FETC:PNO:SWE:LDR?

would return, e.g.:

0.84823463324, 6.55278904401, 1.02393361087,
2.10021296216, 5.28119567376

Usage: Query only

Manual operation: See ["Sweep Result List"](#) on page 15

FETCh:PNOise<t>:SWEep:MDRift?

This command queries the maximum frequency drift in each half decade.

Suffix:

<t> 1..n

Return values:
 <Frequency> Frequency drift as displayed in the Sweep Result List.
 The command returns one value for each half decade as a comma separated list.
 Default unit: Hz

Example: FETC:PNO:SWE:MDR?
 would return, e.g.:
 2.17,11.45,105.11,219.37,553.48

Usage: Query only

Manual operation: See "[Sweep Result List](#)" on page 15

FETCh:PNOise<t>:SWEep:SRATe?

This command queries the sampling rate used in each half decade.

Suffix:
 <t> 1..n

Return values:
 <SamplingRate> Sampling rate as displayed in the Sweep Result List.
 The command returns one value for each half decade as a comma separated list.
 Default unit: Hz

Example: FETC:PNO:SWE:SRAT?
 would return, e.g.:
 25000,75000,250000,750000,2500000

Usage: Query only

Manual operation: See "[Sweep Result List](#)" on page 15

FETCh:PNOise<t>:SWEep:STARt?

This command queries the start frequency offset of each half decade.

Suffix:
 <t> 1..n

Return values:
 <Frequency> Frequency offset as displayed in the Sweep Result List.
 The command returns one value for each half decade as a comma separated list.
 Default unit: Hz

Example: FETC:PNO:SWE:STAR?
 would return, e.g.:
 1000,3000,10000,30000,100000

Usage: Query only

Manual operation: See "[Sweep Result List](#)" on page 15

FETCh:PNOise<t>:SWEep:STOP?

This command queries the stop frequency offset of each half decade.

Suffix:

<t> 1..n

Return values:

<Measurements> Frequency offset as displayed in the Sweep Result List.
The command returns one value for each half decade as a comma separated list.

Default unit: Hz

Example:

FETC:PNO:SWE:STOP?
would return, e.g.:
3000,10000,30000,100000,300000

Usage: Query only

Manual operation: See "[Sweep Result List](#)" on page 15

8.12 Using Markers

The following commands are necessary to control markers.

- [Using Markers](#)..... 137
- [Using Delta Markers](#)..... 139
- [Configuring Markers](#)..... 142
- [Using the Marker Zoom](#)..... 143

8.12.1 Using Markers

- [CALCulate<n>:MARKer<m>:AOFF](#)..... 137
- [CALCulate<n>:MARKer<m>\[:STATE\]](#)..... 138
- [CALCulate<n>:MARKer<m>:TRACe](#)..... 138
- [CALCulate<n>:MARKer<m>:X](#)..... 138
- [CALCulate<n>:MARKer<m>:Y](#)..... 139

CALCulate<n>:MARKer<m>:AOFF

This command turns off all markers.

Suffix:

<n> [Window](#)

<m> [Marker](#)

Example:

CALC:MARK:AOFF
Switches off all markers.

Manual operation: See "[All Markers Off](#)" on page 65

CALCulate<n>:MARKer<m>[:STATe] <State>

This command turns markers on and off. If the corresponding marker number is currently active as a delta marker, it is turned into a normal marker.

Suffix:

<n> [Window](#)

<m> [Marker](#)

Parameters:

<State> ON | OFF | 0 | 1

OFF | 0

Switches the function off

ON | 1

Switches the function on

Example:

```
CALC:MARK3 ON
```

Switches on marker 3.

Manual operation: See "[Marker 1 ... Marker x](#)" on page 64
See "[Marker Type](#)" on page 64

CALCulate<n>:MARKer<m>:TRACe <Trace>

This command selects the trace the marker is positioned on.

Note that the corresponding trace must have a trace mode other than "Blank".

If necessary, the command activates the marker first.

Suffix:

<n> [Window](#)

<m> [Marker](#)

Parameters:

<Trace> **1 to 6**

Trace number the marker is assigned to.

Example:

```
//Assign marker to trace 1
```

```
CALC:MARK3:TRAC 2
```

Manual operation: See "[Assigning the Marker to a Trace](#)" on page 64

CALCulate<n>:MARKer<m>:X <Position>

This command moves a marker to a particular coordinate on the x-axis.

If necessary, the command activates the marker.

If the marker has been used as a delta marker, the command turns it into a normal marker.

Suffix:

<n> 1..n
Window

<m> 1..n
Marker

Parameters:

<Position> Numeric value that defines the marker position on the x-axis.
Default unit: HZ

Example:

CALC:MARK2:X 1.7MHz
Positions marker 2 to frequency 1.7 MHz.

CALCulate<n>:MARKer<m>:Y <Level>**Suffix:**

<n> 1..n

<m> 1..n

Parameters:

<Level>

8.12.2 Using Delta Markers

CALCulate<n>:DELTamarker<m>:AOFF.....	139
CALCulate<n>:DELTamarker<m>:MREFerence.....	139
CALCulate<n>:DELTamarker<m>[:STATe].....	140
CALCulate<n>:DELTamarker<m>:TRACe.....	140
CALCulate<n>:DELTamarker<m>:X.....	141
CALCulate<n>:DELTamarker<m>:Y.....	141

CALCulate<n>:DELTamarker<m>:AOFF

This command turns off *all* delta markers.

Suffix:

<n> Window

<m> irrelevant

Example:

CALC:DELT:AOFF
Turns off all delta markers.

CALCulate<n>:DELTamarker<m>:MREFerence <Reference>

This command selects a reference marker for a delta marker other than marker 1.

The reference may be another marker or the fixed reference.

Suffix:

<n> Window

<m> [Marker](#)

Parameters:

<Reference>

1 to 16

Selects markers 1 to 16 as the reference.

FIXed

Selects the fixed reference as the reference.

Example:

`CALC:DELT3:MREF 2`

Specifies that the values of delta marker 3 are relative to marker 2.

Manual operation: See "[Reference Marker](#)" on page 64

CALCulate<n>:DELTamarker<m>[:STATe] <State>

This command turns delta markers on and off.

If necessary, the command activates the delta marker first.

No suffix at DELTmarker turns on delta marker 1.

Suffix:

<n> [Window](#)

<m> [Marker](#)

Parameters:

<State>

ON | OFF | 0 | 1

OFF | 0

Switches the function off

ON | 1

Switches the function on

Example:

`CALC:DELT2 ON`

Turns on delta marker 2.

Manual operation: See "[Marker 1 ... Marker x](#)" on page 64
See "[Marker Type](#)" on page 64

CALCulate<n>:DELTamarker<m>:TRACe <Trace>

This command selects the trace a delta marker is positioned on.

Note that the corresponding trace must have a trace mode other than "Blank".

If necessary, the command activates the marker first.

Suffix:

<n> [Window](#)

<m> [Marker](#)

Parameters:

<Trace>

Trace number the marker is assigned to.

Example: `CALC:DELT2:TRAC 2`
Positions delta marker 2 on trace 2.

CALCulate<n>:DELTamarker<m>:X <Position>

This command moves a delta marker to a particular coordinate on the x-axis.

If necessary, the command activates the delta marker and positions a reference marker to the peak power.

Suffix:

<n>	1..n Window
<m>	1..n Marker

Parameters:

<Position>	The position is relative to the reference marker. The unit is Hz (offset frequency). A query returns the absolute position of the delta marker. Range: The value range depends on the current measurement range. Default unit: HZ
------------	---

Example: `CALC:DELT:X?`
Outputs the absolute frequency/time of delta marker 1.

CALCulate<n>:DELTamarker<m>:Y <Level>

This command queries the relative position of a delta marker on the y-axis.

If necessary, the command activates the delta marker first.

To get a valid result, you have to perform a complete measurement with synchronization to the end of the measurement before reading out the result. This is only possible for single sweep mode.

See also [INITiate<n>:CONTinuous](#) on page 79.

Suffix:

<n>	1..n Window
<m>	1..n Marker

Parameters:

<Level>	Phase noise level. Default unit: dBc/Hz
---------	--

Example:

```
INIT:CONT OFF
Switches to single sweep mode.
INIT;*WAI
Starts a sweep and waits for its end.
CALC:DELT2 ON
Switches on delta marker 2.
CALC:DELT2:Y?
Outputs measurement value of delta marker 2.
```

8.12.3 Configuring Markers

DISPlay[:WINDow<n>]:MINFo[:STATe].....	142
DISPlay[:WINDow<n>]:MTABLE.....	142

DISPlay[:WINDow<n>]:MINFo[:STATe] <State>

This command turns the marker information in all diagrams on and off.

Suffix:

<n> irrelevant

Parameters:

<State> **ON | 1**
 Displays the marker information in the diagrams.
OFF | 0
 Hides the marker information in the diagrams.
 *RST: 1

Example: DISP:MINF OFF
 Hides the marker information.

Manual operation: See " [Marker Info](#) " on page 65

DISPlay[:WINDow<n>]:MTABLE <DisplayMode>

This command turns the marker table on and off.

Suffix:

<n> irrelevant

Parameters:

<DisplayMode> **ON | 1**
 Turns on the marker table.
OFF | 0
 Turns off the marker table.
AUTO
 Turns on the marker table if 3 or more markers are active.
 *RST: AUTO

Example: DISP:MTAB ON
 Activates the marker table.

Manual operation: See "Marker Table Display" on page 65

8.12.4 Using the Marker Zoom

CALCulate<n>:MARKer<m>:FUNction:ZOOM.....	143
DISPlay[:WINDow<n>]:ZOOM[:STATe].....	143

CALCulate<n>:MARKer<m>:FUNction:ZOOM <ZoomFactor>

This command defines the factor or magnitude of the marker zoom.

Suffix:

<n>	1..n
<m>	1..n

Parameters:

<ZoomFactor>	Range: 1 to 20
	*RST: Zoom OFF

Example: CALC:MARK:FUNC:ZOOM 12
Zooms into the diagram with a factor of 10 around marker 1.

Manual operation: See "Marker Zoom" on page 64

DISPlay[:WINDow<n>]:ZOOM[:STATe] <State>

This command turns the marker zoom for marker 1 on and off.

Suffix:

<n>	1..n
-----	------

Parameters:

<State>	ON OFF 1 0
	*RST: 0

Example: DISP:ZOOM ON
Turns on the marker zoom.

Manual operation: See "Marker Zoom" on page 64

8.13 Configuring In- and Outputs

The following commands are necessary to configure the frontend settings.

INPut<ip>:COUPLing.....	144
INPut<ip>:DPATH.....	144
INPut<ip>:FILTer:YIG[:STATe].....	144
INPut<ip>:CONNector.....	145

INPut<ip>:COUPLing <CouplingType>

This command selects the coupling type of the RF input.

Suffix:

<ip> 1 | 2
 irrelevant

Parameters:

<CouplingType> AC | DC
 AC
 AC coupling
 DC
 DC coupling
 *RST: AC

Example: INP:COUP DC

Manual operation: See "[Coupling](#)" on page 36

INPut<ip>:DPATH <DirectPath>

Enables or disables the use of the direct path for frequencies close to 0 Hz.

Suffix:

<ip> 1 | 2
 irrelevant

Parameters:

<DirectPath> AUTO | OFF
 AUTO | 1
 (Default) the direct path is used automatically for frequencies
 close to 0 Hz.
 OFF | 0
 The analog mixer path is always used.

Example: INP:DPAT OFF

INPut<ip>:FILTer:YIG[:STATe] <State>

Enables or disables the YIG filter.

Suffix:

<ip> 1 | 2
 irrelevant

Parameters:

<State> ON | OFF | 0 | 1

Example: INP:FILT:YIG OFF
 Deactivates the YIG-preselector.

INPut<ip>:CONNector <ConnType>

Determines which connector the input for the measurement is taken from.

Suffix:

<ip> 1 | 2
 irrelevant

Parameters:

<ConnType> **RF**
 RF input connector
 *RST: RF

Example:

INP:CONN RF
Selects input from the RF input connector.

8.14 Automatic Measurement Configuration

The following commands are necessary to determine measurement parameters automatically.

[SENSe:]ADJust:ALL	145
[SENSe:]ADJust:FREQuency	145
[SENSe:]ADJust:LEVel	146

[SENSe:]ADJust:ALL

This command initiates a measurement to determine and set the ideal settings for the current task automatically (only once for the current measurement).

This includes:

- Center frequency
- Reference level

Example: ADJ:ALL

Manual operation: See "[Adjusting all Determinable Settings Automatically \(Auto All \)](#)" on page 45

[SENSe:]ADJust:FREQuency

This command sets the center frequency to the frequency with the highest signal level in the current frequency range.

At the same time, the optimal reference level is also set (see [\[SENSe:\]ADJust:LEVel](#) on page 146).

Example: ADJ:FREQ

Manual operation: See "[Adjusting the Center Frequency Automatically \(Auto Frequency \)](#)" on page 46

[SENSe:]ADJust:LEVel

This command initiates a single (internal) measurement that evaluates and sets the ideal reference level for the current input data and measurement settings. This ensures that the settings of the RF attenuation and the reference level are optimally adjusted to the signal level without overloading the R&S FPS or limiting the dynamic range by an S/N ratio that is too small.

Example: ADJ:LEV

Manual operation: See "[Setting the Reference Level Automatically \(Auto Level \)](#)" on page 46

8.15 Using the Status Register

The status reporting system stores information about the current state of the R&S FPS. This includes, for example, information about errors during operation or information about limit checks. The R&S FPS stores this information in the status registers and in the error queue. You can query the status register and error queue via IEC bus.

The R&S FPS-K40 features several status registers that are specific to phase noise measurements. Here is a description of those, including the corresponding remote commands.

- [Status Registers for Phase Noise Measurements](#)..... 146

8.15.1 Status Registers for Phase Noise Measurements

The figure below shows the status registers of the phase noise application.

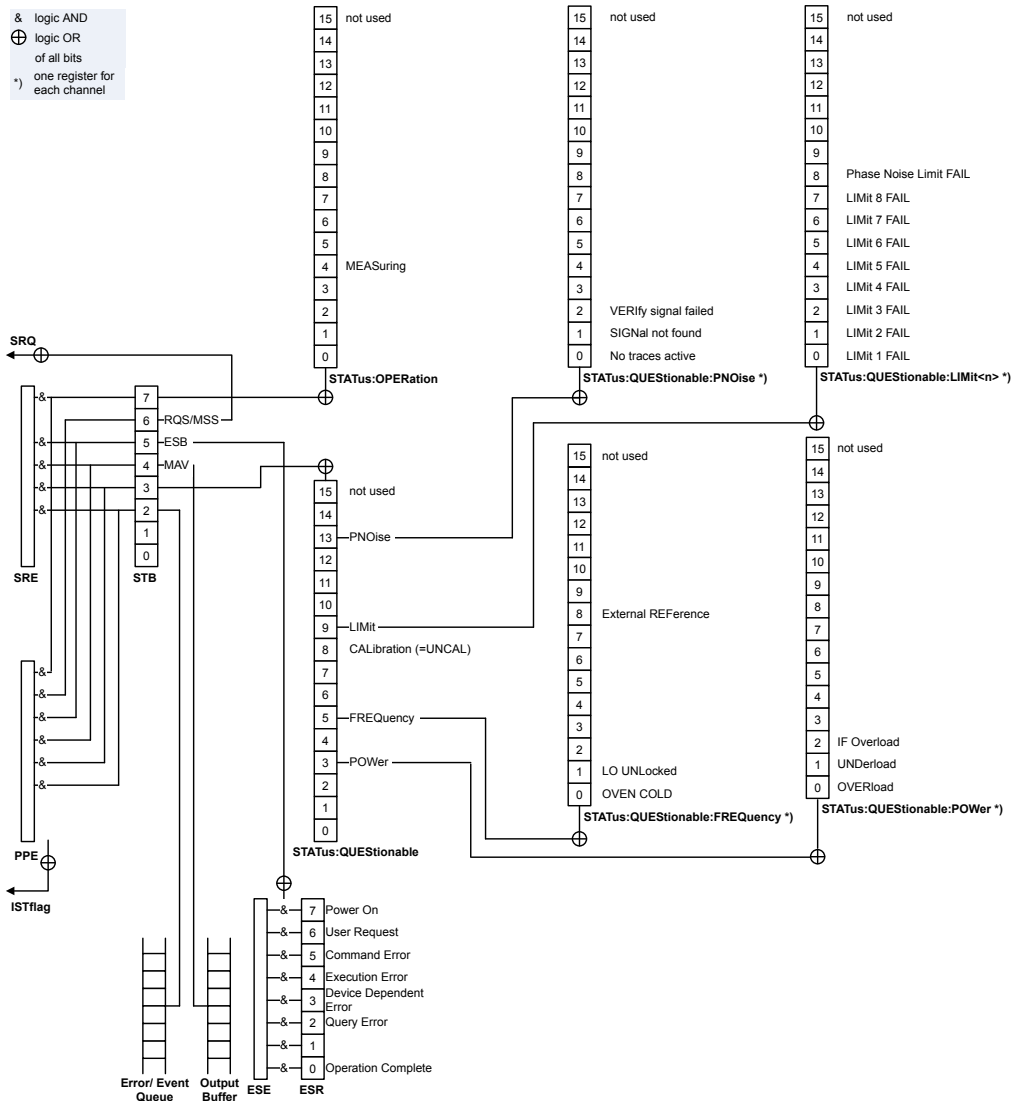

Figure 8-2: Status registers for phase noise measurements

The R&S FPS structures the information hierarchically, with the Status Byte register (STB) and the Service Request Enable mask register (SRE) being on the highest level. The STB gets its information from the standard Event Status Register (ESR) and the Event Status Enable mask register (ESE). The STB and ESR are both defined by IEEE 488.2. In addition to the ESR, the STB also gets information from the STATUS:OPERation and STATUS:QUESTIONable registers. These are the link to the lower levels of the status register and are defined by SCPI. They contain information about the state of the instrument.

For a more comprehensive description of the status registers not mentioned here and status register functionality in general see the manual of the base unit.

- [STATus:QUEStionable Register](#)..... 148
- [STATus:QUEStionable:POWer Register](#)..... 148
- [STATus:QUEStionable:LIMit Register](#)..... 149
- [STATus:QUEStionable:PNOise Register](#)..... 149
- [Status Register Remote Commands](#)..... 150

8.15.1.1 STATus:QUEStionable Register

The `STATus:QUEStionable` register contains information about indefinite states which may occur if the unit is operated without meeting the specifications.

Bit no	Meaning
0 to 2	Unavailable for phase noise measurements.
3	POWer This bit is set if a questionable power occurs.
5 to 7	Unavailable for phase noise measurements.
8	CALibration This bit is set if the R&S FPS is not calibrated.
9	LIMit This bit is set if a limit line is violated.
10-12	Unavailable for phase noise measurements.
13	PNOise This bit is set if the phase noise measurement is questionable.
14	Unavailable for phase noise measurements.
15	This bit is always 0.

8.15.1.2 STATus:QUEStionable:POWer Register

The `STATus:QUEStionable:POWer` register contains information about possible overload situations that may occur during operation of the R&S FPS.

Bit no	Meaning
0	OVERload This bit is set if an overload occurs at the RF input.
1	UNDerload This bit is set if an underload occurs at the RF input.
2	IF OVERload This bit is set if an overload occurs in the IF path.
3 to 14	Unavailable for phase noise measurements.
15	This bit is always 0.

8.15.1.3 STATus:QUEStionable:LIMit Register

The `STATus:QUEStionable:LIMit` register contains information about limit lines and the results of a limit checks.

The number of LIMit registers depends on the number of measurement windows available in any application.

Bit no	Meaning
0	LIMit 1 FAIL This bit is set if limit line 1 is violated.
1	LIMit 2 FAIL This bit is set if limit line 2 is violated.
2	LIMit 3 FAIL This bit is set if limit line 3 is violated.
3	LIMit 4 FAIL This bit is set if limit line 4 is violated.
4	LIMit 5 FAIL This bit is set if limit line 5 is violated.
5	LIMit 6 FAIL This bit is set if limit line 6 is violated.
6	LIMit 7 FAIL This bit is set if limit line 7 is violated.
7	LIMit 8 FAIL This bit is set if limit line 8 is violated.
8	Phase Noise LIMit FAIL This bit is set if a limit of the phase noise limit line is violated.
9 to 14	Unavailable for phase noise measurements.
15	This bit is always 0.

8.15.1.4 STATus:QUEStionable:PNOise Register

The `STATus:QUEStionable:PNOise` register contains information about the status of phase noise measurements.

Bit no	Meaning
0	No trace are active This bit is set if no trace is on.
1	SIGNal not found This bit is set if no valid signal could be found.
2	VERify This bit is set if signal verification has failed.

Bit no	Meaning
3 to 14	Unavailable for phase noise measurements.
15	This bit is always 0.

8.15.1.5 Status Register Remote Commands

STATus:OPERation[:EVENT]?	150
STATus:QUESTionable[:EVENT]?	150
STATus:QUESTionable:LIMit[:EVENT]?	150
STATus:QUESTionable:PNOise[:EVENT]?	150
STATus:QUESTionable:POWer[:EVENT]?	150
STATus:OPERation:CONDition?	151
STATus:QUESTionable:CONDition?	151
STATus:QUESTionable:LIMit:CONDition?	151
STATus:QUESTionable:PNOise:CONDition?	151
STATus:QUESTionable:POWer:CONDition?	151
STATus:OPERation:ENABLE	151
STATus:QUESTionable:ENABLE	151
STATus:QUESTionable:LIMit:ENABLE	151
STATus:QUESTionable:PNOise:ENABLE	151
STATus:QUESTionable:POWer:ENABLE	151
STATus:OPERation:NTRansition	151
STATus:QUESTionable:NTRansition	151
STATus:QUESTionable:LIMit:NTRansition	151
STATus:QUESTionable:PNOise:NTRansition	151
STATus:QUESTionable:POWer:NTRansition	151
STATus:OPERation:PTRansition	152
STATus:QUESTionable:PTRansition	152
STATus:QUESTionable:LIMit:PTRansition	152
STATus:QUESTionable:PNOise:PTRansition	152
STATus:QUESTionable:POWer:PTRansition	152

STATus:OPERation[:EVENT]?

STATus:QUESTionable[:EVENT]?

STATus:QUESTionable:LIMit[:EVENT]? <ChannelName>

STATus:QUESTionable:PNOise[:EVENT]? <ChannelName>

STATus:QUESTionable:POWer[:EVENT]? <ChannelName>

These commands read out the EVENT section of the status register.

The commands at the same time delete the contents of the EVENT section.

Query parameters:

<ChannelName> String containing the name of the channel.
The parameter is optional. If you omit it, the command works for the currently active channel.

Usage: Query only

STATus:OPERation:CONDition?
STATus:QUESTionable:CONDition?
STATus:QUESTionable:LIMit:CONDition? <ChannelName>
STATus:QUESTionable:PNOise:CONDition? <ChannelName>
STATus:QUESTionable:POWer:CONDition? <ChannelName>

These commands read out the CONDition section of the status register.

The commands do not delete the contents of the EVENT section.

Query parameters:

<ChannelName> String containing the name of the channel.
 The parameter is optional. If you omit it, the command works for the currently active channel.

Usage: Query only

STATus:OPERation:ENABLE <SumBit>,<ChannelName>
STATus:QUESTionable:ENABLE <SumBit>,<ChannelName>
STATus:QUESTionable:LIMit:ENABLE <SumBit>,<ChannelName>
STATus:QUESTionable:PNOise:ENABLE <SumBit>,<ChannelName>
STATus:QUESTionable:POWer:ENABLE <SumBit>,<ChannelName>

These commands control the ENABLE part of a register.

The ENABLE part allows true conditions in the EVENT part of the status register to be reported in the summary bit. If a bit is 1 in the enable register and its associated event bit transitions to true, a positive transition will occur in the summary bit reported to the next higher level.

Parameters:

<SumBit> Range: 0 to 65535
 <ChannelName> String containing the name of the channel.
 The parameter is optional. If you omit it, the command works for the currently active channel.

STATus:OPERation:NTRansition <SumBit>,<ChannelName>
STATus:QUESTionable:NTRansition <SumBit>,<ChannelName>
STATus:QUESTionable:LIMit:NTRansition <SumBit>,<ChannelName>
STATus:QUESTionable:PNOise:NTRansition <SumBit>,<ChannelName>
STATus:QUESTionable:POWer:NTRansition <SumBit>,<ChannelName>

These commands control the Negative TRansition part of a register.

Setting a bit causes a 1 to 0 transition in the corresponding bit of the associated register. The transition also writes a 1 into the associated bit of the corresponding EVENT register.

Parameters:

<SumBit> Range: 0 to 65535

<ChannelName> String containing the name of the channel.
The parameter is optional. If you omit it, the command works for the currently active channel.

STATus:OPERation:PTRansition <SumBit>,<ChannelName>
STATus:QUESTionable:PTRansition <SumBit>,<ChannelName>
STATus:QUESTionable:LIMit:PTRansition <SumBit>,<ChannelName>
STATus:QUESTionable:PNOise:PTRansition <SumBit>,<ChannelName>
STATus:QUESTionable:POWer:PTRansition <SumBit>,<ChannelName>

These commands control the Positive TRansition part of a register.

Setting a bit causes a 0 to 1 transition in the corresponding bit of the associated register. The transition also writes a 1 into the associated bit of the corresponding EVENT register.

Parameters:

<SumBit> Range: 0 to 65535

<ChannelName> String containing the name of the channel.
The parameter is optional. If you omit it, the command works for the currently active channel.

8.16 Remote Control Example Scripts

This chapter contains a few remote control example scripts for particular phase noise measurement and configuration tasks.

The first chapter contains a short sequence of commands to perform a complete phase noise measurement. The subsequent chapters contain sequences of remote commands to perform special tasks for phase noise measurements like customizing the half decade configuration table.

All examples are based on a measurement range from 100 Hz to 1 MHz.

8.16.1 Performing a Basic Phase Noise Measurement

```
//Enter Phase Noise application
INST:SEL PNO
//Perform a preset of the channel
SYST:PRES:CHAN
//Customizing the screen layout.
//Add residual noise window:
LAY:ADD? '1',BEL,RNO
//Add spot noise window:
LAY:ADD? '2',RIGH,SNO
//Configure single sweep measurement.
INIT:CONT OFF
//Define the measurement range.
```



```

FREQ:STAR 100HZ
FREQ:STOP 1MHZ
//Select the sweep type.
SWE:MODE AVER
//Turn on frequency tracking.
FREQ:TRAC ON
//Turn on level tracking.
POW:TRAC ON
//Start the measurement with synchronization.
INIT;*WAI
//Set a marker on trace 1 and query its position.
CALC:MARK ON
CALC:MARK:X 1MHZ
CALC:MARK:Y?
//Query the residual noise results of trace 2 over the measurement range.
CALC:EVAL ON
//Residual FM:
FETC:PNO2:RFM?
//Residual PM:
FETC:PNO2:RPM?
//Residual RMS jitter:
FETC:PNO2:RMS?
//Freeze trace 1 and trace 2.
DISP:TRAC:MODE VIEW
DISP:TRAC2:MODE VIEW
//Activate trace 3 and trace 4.
DISP:TRAC3:MODE WRIT
DISP:TRAC4:MODE WRIT
//Activate linear trace smoothing for trace 4.
DISP:TRAC4:SMO ON
DISP:TRAC4:SMO:TYPE LIN
DISP:TRAC:SMO:APER 1
//Select IQ sweep mode.
SWE:MODE MAN
LIST:BWID:RES:TYPE IQFF
//Repeat the measurement.
INIT;*WAI

```

8.16.2 Configuring the Measurement Range

Performing a customized IQ FFT measurement over the whole measurement range

```

//Define the measurement range.
FREQ:STAR 100HZ
FREQ:STOP 1MHZ
//Define the measurement settings for all half decades in the measurement range.
SWE:MODE MAN

```

```
//Measurement bandwidth (in per cent of the decade frequency):
LIST:BWID:RAT 20
//Averages:
LIST:SWE:COUN 20
//Mode:
LIST:BWID:RES:TYPE IQFF
//Window function:
LIST:IQW:TYPE GAUS
```

Customizing a half decade configuration table

```
//Define the measurement range.
FREQ:STAR 100HZ
FREQ:STOP 1MHZ
//Define the contents of the table manually.
SWE:MODE MAN
//Customize the range from 100 Hz to 300 Hz.
//Measurement bandwidth:
LIST:RANG5:BWID 1HZ
//Sweep type:
LIST:RANG5:FILT:TYPE IQFF
//Window function:
LIST:RANG5:IQW:TYPE CHEB
//Averages:
LIST:RANG5:SWE:COUN 5
//Customize the range from 300 Hz to 1 kHz.
//Averages:
LIST:RANG6:SWE:COUN 5
```

8.16.3 Scaling the Display

Scaling the x-axis: displaying a half decade

```
//Select display of one half decade.
DISP:TRAC:X:SCOP HDEC
//Select the start frequency of the half decade.
DISP:TRAC:X:HDEC 1KHZ
//Display the full measurement range again.
DISP:TRAC:X:SCOP MRAN
```

Scaling the x-axis: customizing the x-axis range

```
//Select manual x-axis scaling.
DISP:TRAC:X:SCOP MAN
//Define the start frequency of the display range.
DISP:TRAC:X:STAR 30KHZ
//Define the stop frequency of the display range.
DISP:TRAC:X:STOP 300KHZ
```

Scaling the y-axis: scaling based on bottom value and range

```
//Select manual y-axis scaling.
DISP:TRAC:Y:MAN BRAN
//Define the bottom value.
DISP:TRAC:Y:RLEV:LOW -160
//Define the range.
DISP:TRAC:Y 60
```

Scaling the y-axis: scaling based on top value and range

```
//Select manual y-axis scaling.
DISP:TRAC:Y:MAN TRAN
//Define the top value.
DISP:TRAC:Y:RLEV -100
//Define the range.
DISP:TRAC:Y 60
```

Scaling the y-axis: scaling based on bottom and top value

```
//Select manual y-axis scaling.
DISP:TRAC:Y:MAN TBOT
//Define the bottom value.
DISP:TRAC:Y:RLEV:LOW -160
//Define the top value.
DISP:TRAC:Y:RLEV -100
```

8.16.4 Configuring Numerical Results**Defining a user range for residual noise results and query the results**

```
//Select the trace for integration.
CALC:EVAL:USER2:TRAC TRACE1
//Define the start and stop frequencies of the integration range.
CALC:EVAL:USER2:STAR 100KHZ
CALC:EVAL:USER2:STOP 1MHZ
//Query the results.
//Residual FM:
FETC:PNO:USER2:RFM?
//Residual PM:
FETC:PNO:USER2:RPM?
//Residual RMS jitter:
FETC:PNO:USER2:RMS?
```

Working with spot noise results

```
//Turn on spot noise markers on every decade edge.
CALC:SNO:DEC ON
//Turn on spot noise markers at two additional offset frequencies.
CALC:SNO1:STAT ON
```

```

CALC:SNO1:X 50KHZ
CALC:SNO2:STAT ON
CALC:SNO2:X 500KHZ
//Read out spot noise marker results.
//Read out the decade edges:
CALC:SNO:DEC:X?
//Read out the marker positions on the decade edges:
CALC:SNO:DEC:Y?
//Read out customized spot noise marker results:
//At 50 kHz:
CALC:SNO1:Y?
//At 500 kHz:
CALC:SNO2:Y?

```

8.16.5 Using Limit Lines

Programming a phase noise limit line with three segments

```

//Define the level of the DUT's noise floor.
CALC:PNL:NOIS -134
//Select the number of line segments.
CALC:PNL:TYPE FC3
//Define the characteristics of the line segments.
CALC:PNL:FC1 300KHZ
CALC:PNL:SLOP1 10
CALC:PNL:FC2 30KHZ
CALC:PNL:SLOP2 20
CALC:PNL:FC3 3KHZ
CALC:PNL:SLOP3 30
//Assign the limit line to trace 1 and 2.
CALC:PNL:TRAC 1,2
//Query limit check results.
CALC:PNL:FAIL?

```

Programming a standard limit line

```

//Select or create the limit line by name.
CALC:LIM:NAME 'Phase Noise'
//Comment on the limit line.
CALC:LIM:COMM 'Limit line to test phase noise measurement'
//Define the horizontal data points of the limit line.
CALC:LIM:CONT 100HZ,1kHZ
//Define the vertical data points of an (upper) limit line.
//The unit is fix for phase noise measurements.
CALC:LIM:UPP -160,-170
//Shift the limit line 5 dBc/Hz down.
CALC:LIM:UPP:SHIF -5
//Turn the limit line on.
CALC:LIM:UPP:STAT ON

```

```
//Select the trace to check.  
CALC:LIM:TRAC 3  
//Turn on the limit check.  
CALC:LIM:STAT ON  
//Query the limit check results.  
CALC:LIM:FAIL?
```

8.16.6 Using Markers

Using spot noise markers

See ["Working with spot noise results"](#) on page 155.

Using normal and delta markers

```
//Activate and position a normal marker (marker 1).  
CALC:MARK ON  
CALC:MARK:X 1MHZ  
//Position marker 1 on trace 2.  
CALC:MARK:TRAC 2  
//Query the position of marker 1.  
CALC:MARK:Y?  
//Activate and position a delta marker (delta marker 1).  
CALC:DELT ON  
CALC:DELT:X -900KHZ  
//Position the delta marker on trace 2.  
CALC:DELT:TRAC 2  
//Query the position of the delta marker.  
CALC:DELT:Y?  
//Turning all markers off  
CALC:MARK:AOFF  
CALC:DELT:AOFF
```

List of Remote Commands (Phase Noise)

[SENSe:]ADJust:ALL.....	145
[SENSe:]ADJust:FREQuency.....	145
[SENSe:]ADJust:LEVel.....	146
[SENSe:]FREQuency:CENTer.....	89
[SENSe:]FREQuency:STARt.....	96
[SENSe:]FREQuency:STOP.....	96
[SENSe:]FREQuency:TRACk.....	91
[SENSe:]FREQuency:VERify:TOLerance:ABSolute.....	91
[SENSe:]FREQuency:VERify:TOLerance[:RELative].....	91
[SENSe:]FREQuency:VERify[:STATe].....	92
[SENSe:]IQ:DECimation.....	92
[SENSe:]IQ:DPLL.....	92
[SENSe:]IQ:TBW.....	93
[SENSe:]LIST:BWIDth[:RESolution]:RATio.....	95
[SENSe:]LIST:BWIDth[:RESolution]:TYPE.....	96
[SENSe:]LIST:RANGe<range>:BWIDth[:RESolution].....	97
[SENSe:]LIST:RANGe<range>:FILTer:TYPE.....	97
[SENSe:]LIST:RANGe<range>:IQWindow:TYPE.....	97
[SENSe:]LIST:RANGe<range>:SWEep:COUNT.....	98
[SENSe:]LIST:SWEep:COUNT.....	98
[SENSe:]LIST:SWEep:COUNT:MULTIplier.....	99
[SENSe:]LIST:SWEep:COUNT:MULTIplier:STATe.....	99
[SENSe:]POWer:RLEVel.....	89
[SENSe:]POWer:RLEVel:VERify:TOLerance.....	93
[SENSe:]POWer:RLEVel:VERify[:STATe].....	93
[SENSe:]POWer:TRACk.....	93
[SENSe:]REJect:AM.....	94
[SENSe:]SPURs:SUPPRes.....	122
[SENSe:]SPURs:THReshold.....	122
[SENSe:]SWEep:COUNT.....	100
[SENSe:]SWEep:FHDecade.....	81
[SENSe:]SWEep:FORWard.....	99
[SENSe:]SWEep:MODE.....	100
[SENSe:]SWEep:SVFailed.....	94
ABORT.....	78
CALCulate:PNLimit:FC1 <Frequency>.....	101
CALCulate:PNLimit:FC2 <Frequency>.....	101
CALCulate:PNLimit:FC3 <Frequency>.....	101
CALCulate:PNLimit:FC4 <Frequency>.....	101
CALCulate<n>:DELTamarker<m>:AOFF.....	139
CALCulate<n>:DELTamarker<m>:MREFerence.....	139
CALCulate<n>:DELTamarker<m>:TRACe.....	140
CALCulate<n>:DELTamarker<m>:X.....	141
CALCulate<n>:DELTamarker<m>:Y.....	141
CALCulate<n>:DELTamarker<m>[:STATe].....	140
CALCulate<n>:EVALuation:STARt.....	124
CALCulate<n>:EVALuation:STOP.....	125

CALCulate<n>:EVALuation:USER<range>:START.....	125
CALCulate<n>:EVALuation:USER<range>:STOP.....	125
CALCulate<n>:EVALuation:USER<range>:TRACe.....	126
CALCulate<n>:EVALuation[:STATe].....	124
CALCulate<n>:LIMit:ACTive?.....	104
CALCulate<n>:LIMit:CLEar[:IMMediate].....	104
CALCulate<n>:LIMit:COMMeNt.....	108
CALCulate<n>:LIMit:CONTRol:SHIFt.....	109
CALCulate<n>:LIMit:CONTRol[:DATA].....	108
CALCulate<n>:LIMit:COpy.....	104
CALCulate<n>:LIMit:DELeTe.....	105
CALCulate<n>:LIMit:FAIL?.....	105
CALCulate<n>:LIMit:LOWer:MODE.....	110
CALCulate<n>:LIMit:LOWer:SHIFt.....	110
CALCulate<n>:LIMit:LOWer:STATe.....	106
CALCulate<n>:LIMit:LOWer[:DATA].....	109
CALCulate<n>:LIMit:NAME.....	105
CALCulate<n>:LIMit:STATe.....	106
CALCulate<n>:LIMit:TRACe<t>.....	107
CALCulate<n>:LIMit:TRACe<t>:CHECK.....	107
CALCulate<n>:LIMit:UPPer:MODE.....	110
CALCulate<n>:LIMit:UPPer:SHIFt.....	111
CALCulate<n>:LIMit:UPPer:STATe.....	107
CALCulate<n>:LIMit:UPPer[:DATA].....	111
CALCulate<n>:MARKer<m>:AOFF.....	137
CALCulate<n>:MARKer<m>:FUNCTion:ZOOM.....	143
CALCulate<n>:MARKer<m>:TRACe.....	138
CALCulate<n>:MARKer<m>:X.....	138
CALCulate<n>:MARKer<m>:Y.....	139
CALCulate<n>:MARKer<m>[:STATe].....	138
CALCulate<n>:MATH<t>:STATe.....	113
CALCulate<n>:MATH<t>[:EXPRession][:DEFine].....	112
CALCulate<n>:PNLimit:COpy<k>.....	101
CALCulate<n>:PNLimit:FAIL?.....	103
CALCulate<n>:PNLimit:FC<1 to 5>.....	101
CALCulate<n>:PNLimit:NOISe.....	101
CALCulate<n>:PNLimit:SLOPe<segment>.....	103
CALCulate<n>:PNLimit:TRACe.....	102
CALCulate<n>:PNLimit:TYPE.....	102
CALCulate<n>:SNOise<m>:AOFF.....	129
CALCulate<n>:SNOise<m>:DECades:X.....	130
CALCulate<n>:SNOise<m>:DECades:Y.....	130
CALCulate<n>:SNOise<m>:DECades[:STATe].....	129
CALCulate<n>:SNOise<m>:X.....	131
CALCulate<n>:SNOise<m>:Y.....	131
CALCulate<n>:SNOise<m>[:STATe].....	131
CONFigure:REFMeas.....	78
DISPlay:FORMat.....	82
DISPlay[:WINDow<n>]:MINFo[:STATe].....	142
DISPlay[:WINDow<n>]:MTABLE.....	142

DISPlay[:WINDow<n>]:SIZE.....	82
DISPlay[:WINDow<n>]:TRACe<t>:MODE.....	113
DISPlay[:WINDow<n>]:TRACe<t>:SElect.....	132
DISPlay[:WINDow<n>]:TRACe<t>:SMOothing:TYPE.....	114
DISPlay[:WINDow<n>]:TRACe<t>:SPURs:SUPPress.....	115
DISPlay[:WINDow<n>]:TRACe<t>:X[:SCALe]:HDECade.....	115
DISPlay[:WINDow<n>]:TRACe<t>:X[:SCALe]:SCOPE.....	116
DISPlay[:WINDow<n>]:TRACe<t>:X[:SCALe]:START.....	116
DISPlay[:WINDow<n>]:TRACe<t>:X[:SCALe]:STOP.....	117
DISPlay[:WINDow<n>]:TRACe<t>:Y[:SCALe].....	117
DISPlay[:WINDow<n>]:TRACe<t>:Y[:SCALe]:AUTO.....	118
DISPlay[:WINDow<n>]:TRACe<t>:Y[:SCALe]:MANual.....	118
DISPlay[:WINDow<n>]:TRACe<t>:Y[:SCALe]:RLEVel.....	119
DISPlay[:WINDow<n>]:TRACe<t>:Y[:SCALe]:RLEVel:LOWer.....	119
DISPlay[:WINDow<n>]:TRACe<t>:Y[:SCALe]:RLEVel:OFFSet.....	119
DISPlay[:WINDow<n>]:ZOOM[:STATe].....	143
DISPlay[:WINDow<n>][:SUBWindow<w>]:TRACe<t>:SMOothing:APERture.....	113
DISPlay[:WINDow<n>][:SUBWindow<w>]:TRACe<t>:SMOothing[:STATe].....	114
DISPlay[:WINDow<n>][:SUBWindow<w>]:TRACe<t>[:STATe].....	115
FETCh:PNOise<t>:IPN?.....	126
FETCh:PNOise<t>:MEASured:FREQuency?.....	133
FETCh:PNOise<t>:MEASured:LEVel?.....	134
FETCh:PNOise<t>:RFM?.....	127
FETCh:PNOise<t>:RMS?.....	127
FETCh:PNOise<t>:RPM?.....	127
FETCh:PNOise<t>:SPURs:DISCReTe?.....	133
FETCh:PNOise<t>:SPURs:RANDom?.....	133
FETCh:PNOise<t>:SPURs?.....	132
FETCh:PNOise<t>:SWEep:AVG?.....	134
FETCh:PNOise<t>:SWEep:FDRift?.....	135
FETCh:PNOise<t>:SWEep:LDRift?.....	135
FETCh:PNOise<t>:SWEep:MDRift?.....	135
FETCh:PNOise<t>:SWEep:SRATe?.....	136
FETCh:PNOise<t>:SWEep:START?.....	136
FETCh:PNOise<t>:SWEep:STOP?.....	137
FETCh:PNOise<t>:USER<range>:IPN?.....	127
FETCh:PNOise<t>:USER<range>:RFM?.....	128
FETCh:PNOise<t>:USER<range>:RMS?.....	128
FETCh:PNOise<t>:USER<range>:RPM?.....	128
FORMat:DEXPort:DSEParator.....	120
FORMat:DEXPort:HEADer.....	120
FORMat:DEXPort:TRACes.....	120
FORMat:DEXPort:XDIStrib.....	121
FORMat:DIMPort:TRACes.....	121
INITiate:SEQuencer:ABORT.....	80
INITiate:SEQuencer:IMMediate.....	80
INITiate:SEQuencer:MODE.....	80
INITiate<n>:CONMeas.....	78
INITiate<n>:CONTinuous.....	79
INITiate<n>[:IMMediate].....	79

INPut:GAIN:STATe.....	90
INPut<ip>:ATTenuation.....	89
INPut<ip>:ATTenuation:AUTO.....	90
INPut<ip>:CONNector.....	145
INPut<ip>:COUPling.....	144
INPut<ip>:DPATH.....	144
INPut<ip>:FILTer:YIG[:STATe].....	144
INSTrument:CREate:DUPLicate.....	74
INSTrument:CREate:REPLace.....	74
INSTrument:CREate[:NEW].....	74
INSTrument:DELeTe.....	75
INSTrument:LIST?.....	75
INSTrument:REName.....	76
INSTrument[:SElect].....	77
LAYout:ADD[:WINDow]?.....	83
LAYout:CATalog[:WINDow]?.....	84
LAYout:IDENtify[:WINDow]?.....	84
LAYout:REMove[:WINDow].....	85
LAYout:REPLace[:WINDow].....	85
LAYout:SPLitter.....	85
LAYout:WINDow<n>:ADD?.....	87
LAYout:WINDow<n>:IDENtify?.....	87
LAYout:WINDow<n>:REMove.....	88
LAYout:WINDow<n>:REPLace.....	88
MMEMory:LOAD<n>:TRACe.....	122
MMEMory:STORE<n>:TRACe.....	122
STATus:OPERation:CONDition?.....	151
STATus:OPERation:ENABle.....	151
STATus:OPERation:NTRansition.....	151
STATus:OPERation:PTRansition.....	152
STATus:OPERation[:EVENT]?.....	150
STATus:QUEStionable:CONDition?.....	151
STATus:QUEStionable:ENABle.....	151
STATus:QUEStionable:LIMit:CONDition?.....	151
STATus:QUEStionable:LIMit:ENABle.....	151
STATus:QUEStionable:LIMit:NTRansition.....	151
STATus:QUEStionable:LIMit:PTRansition.....	152
STATus:QUEStionable:LIMit[:EVENT]?.....	150
STATus:QUEStionable:NTRansition.....	151
STATus:QUEStionable:PNOise:CONDition?.....	151
STATus:QUEStionable:PNOise:ENABle.....	151
STATus:QUEStionable:PNOise:NTRansition.....	151
STATus:QUEStionable:PNOise:PTRansition.....	152
STATus:QUEStionable:PNOise[:EVENT]?.....	150
STATus:QUEStionable:POWer:CONDition?.....	151
STATus:QUEStionable:POWer:ENABle.....	151
STATus:QUEStionable:POWer:NTRansition.....	151
STATus:QUEStionable:POWer:PTRansition.....	152
STATus:QUEStionable:POWer[:EVENT]?.....	150
STATus:QUEStionable:PTRansition.....	152

STATus:QUESTionable[:EVENT]?	150
SYSTem:PRESet:CHANnel[:EXEC]	77
SYSTem:SEQuencer	81
TRACe<n>:COPY	123
TRACe<n>[:DATA]	123

Index

A

Abort measurement (remote control)	77
Aborting	
Sweep	44
Attenuation	
Mechanical	36
Mechanical (remote control)	89
Auto all	45
Auto frequency	46
Auto level	
Reference level	46
Softkey	46
Automatic	
Frequency detection (remote control)	145
Level detection (remote control)	145
Parameter detection (remote control)	145
Automatic scaling	49
Automatic scaling (remote control)	111
Average count	44
Averaging	41, 43
Averaging (remote control)	94

C

Center frequency	
Automatic configuration	46
Channel	
Creating (remote)	74
Deleting (remote)	75
Duplicating (remote)	74
Querying (remote)	75
Renaming (remote)	76
Replacing (remote)	74
Closing	
Channels (remote)	75
Windows (remote)	88
Continue single sweep	
Softkey	44
Continuous sweep	
Softkey	44
Conventions	
SCPI commands	69
Copy trace (remote control)	111
Copying	
Channel (remote)	74
Traces	51
Coupling	36, 45
Coupling (remote control)	89

D

Data format	
Remote	120
Decimal separator	
Trace export	52
Delta markers	64
Defining	64
Delta markers (remote control)	137
Duplicating	
Channel (remote)	74

E

Evaluation methods	
Remote	83
Exporting	
Measurement settings	52
Traces	51, 53

F

FFT window	42
FFT window (remote control)	94
Filters	
YIG (remote)	144
Format	
Data (remote)	120
Frequency	
Nominal	36
Nominal (remote control)	89
Frequency tolerance	38
Frequency tolerance (remote control)	91
Frequency tracking	38
Frequency tracking (remote control)	91
Frequency verification	38
Frequency verification (remote control)	91

G

Group delay	
Smoothing	50

H

Half decades configuration table	43
Hardware settings	
Displayed	9

I

Initiate measurement (remote control)	77
Installation	6

J

Jitter (remote control)	123
-------------------------------	-----

K

Keys	
RUN CONT	44
RUN SINGLE	44

L

Level	
nominal	36
Nominal (remote control)	89
Level tolerance	38
Level tolerance (remote control)	91
Level tracking	39
Level tracking (remote control)	91
Level verification	38
Level verification (remote control)	91

- Limit lines
 - Noise floor (remote control) 101
 - Phase noise (remote control) 101
 - Standard (remote control) 103
- Limit lines (remote control) 100
- M**
- Marker to Trace 64
- Marker zoom (remote control) 143
- Markers 32
 - Assigned trace 64
 - Deactivating 65
 - Delta markers 64
 - Table 65
 - Type 64
- Markers (remote control) 139
- Maximizing
 - Windows (remote) 82
- Measurement range 40
- Measurement range (remote control) 94
- Measurement time 43
- Mechanical attenuation 36
- Mechanical attenuation (remote control) 89
- Multiple
 - Measurement channels 7
- N**
- Nominal frequency 36
- Nominal frequency (remote control) 89
- Nominal level 36
- Nominal level (remote control) 89
- O**
- Offset frequency
 - Start 40
 - Start (remote control) 94
 - Stop 40
 - Stop (remote control) 94
- Options
 - Preamplifier (B24) 37
- Overview
 - Configuration 33
- P**
- Preamplifier
 - Setting 37
 - Softkey 37
- Presetting
 - Channels 35
- Q**
- Quick Config
 - Traces 50
- R**
- Range Start/Stop 40
- Range Start/Stop (remote control) 94
- RBW 41, 43
- RBW (remote control) 94
- Reference level
 - Auto level 46
- Reference marker 64
- Remote commands
 - Basics on syntax 69
 - Boolean values 72
 - Capitalization 70
 - Character data 73
 - Data blocks 73
 - Numeric values 72
 - Optional keywords 71
 - Parameters 71
 - Strings 73
 - Suffixes 70
- Residual FM (remote control) 123
- Residual noise
 - Integration range 55
 - Integration Range 55
 - Integration Range (remote control) 123
- Residual noise (remote control) 123
- Residual PM (remote control) 123
- Resolution bandwidth 41, 43
- Resolution bandwidth (remote control) 94
- Restoring
 - Channel settings 35
- Results
 - Data format (remote) 120
 - Exporting 52
- RUN CONT
 - Key 44
- RUN SINGLE
 - Key 44
- S**
- Scaling
 - X-axis 47
 - X-axis (remote control) 111
 - Y-axis 48
 - Y-axis (remote control) 111
- Scope
 - X-axis 47
 - X-axis (remote control) 111
- Sequencer 7
 - Activating (remote) 80
 - Remote 79
- Sequences
 - Aborting (remote) 80
 - Mode (remote) 80
- Single sweep
 - Softkey 44
- Smoothing
 - Traces 23
 - Traces (group delay) 50
- Smoothing type (remote control) 111
- Softkeys
 - Auto All 45
 - Auto Freq 46
 - Auto Level 46
 - Continue Single Sweep 44
 - Continuous Sweep 44
 - Marker to Trace 64
 - Norm/Delta 64
 - Preamp 37
 - Single Sweep 44
 - Sweep Count 44
 - Trace Config 53
- Spot noise
 - 10_x Hz 56
 - 10_x Hz (remote control) 123

user defined	56
user defined (remote control)	123
Spur removal	50
Spur removal (remote control)	111
Spur threshold	50
Spur threshold (remote control)	111
Stop On Verify Failed	38
Suffixes	
Common	68
Remote commands	70
Sweep	
Aborting	44
Sweep Count	44
Sweep count (remote control)	77
Sweep direction	41
Sweep direction (remote control)	94
Sweep mode	42, 43
Sweep mode (remote control)	94
Sweep type	41
Sweep type (remote control)	94
T	
Tolerance	
frequency	38
frequency (remote control)	91
level	38
level (remote control)	91
Trace configuration (remote control)	111
Trace copy (remote control)	111
Trace export (remote control)	111
Trace math	
Functions	54
Settings	53
Trace math (remote control)	111
Trace offset	49
Trace offset (remote control)	111
Trace smoothing	23
Trace smoothing (remote control)	111
Traces	
Configuration (Softkey)	53
Copying	51
Copying (remote control)	123
Export format	52
Exporting	51, 52, 53
Mode	49
Mode (remote)	113
Settings, predefined	50
Tracking	
frequency	38
frequency (remote control)	91
level	39
level (remote control)	91
V	
Verify frequency	38
Verify frequency (remote control)	91
Verify level	38
Verify level (remote control)	91
W	
Window function	42
Window function (remote control)	94
Window title bar information	10

Windows	
Adding (remote)	83
Closing (remote)	88
Layout (remote)	85
Maximizing (remote)	82
Querying (remote)	84
Replacing (remote)	85
Splitting (remote)	82
Types (remote)	83

X

X-axis	
Half decade	48
Half decade (remote control)	111
scope	47
scope (remote control)	111
Start	48
Start (remote control)	111
Stop	48
Stop (remote control)	111

Y

Y-axis	
Scaling	48
Scaling (remote control)	111
Scaling automatic (remote control)	111
Y-axis scaling	
Automatic	49
YIG-preselector	
Activating/Deactivating (remote)	144