

# R&S<sup>®</sup>SMBVB-K42/-K83

## 3GPP FDD incl. enhanced MS/BS tests, HSPA, HSPA+ User Manual



1178810702  
Version 09

**ROHDE & SCHWARZ**  
Make ideas real



This document describes the following software options:

- R&S®SMBVB-K42 3GPP FDD (1423.7747.xx)
- R&S®SMBVB-K83 3GPP HSPA/HSPA+ and enhanced BS/MS tests (1423.7899.xx)

This manual describes firmware version FW 5.30.047.xx and later of the R&S®SMBV100B.

© 2023 Rohde & Schwarz

Muehldorfstr. 15, 81671 Muenchen, Germany

Phone: +49 89 41 29 - 0

Email: [info@rohde-schwarz.com](mailto:info@rohde-schwarz.com)

Internet: [www.rohde-schwarz.com](http://www.rohde-schwarz.com)

Subject to change – data without tolerance limits is not binding.

R&S® is a registered trademark of Rohde & Schwarz GmbH & Co. KG.

All other trademarks are the properties of their respective owners.

1178.8107.02 | Version 09 | R&S®SMBVB-K42/-K83

The following abbreviations are used throughout this manual: R&S®SMBV100B is abbreviated as R&S SMBVB, R&S®WinIQSIM2™ is abbreviated as R&S WinIQSIM2; the license types 02/03/07/11/13/16/12 are abbreviated as xx.

# Contents

<b>1</b>	<b>Welcome to the 3GPP FDD options.....</b>	<b>9</b>
1.1	Accessing the 3GPP FDD dialog.....	11
1.2	What's new.....	11
1.3	Documentation overview.....	11
1.3.1	Getting started manual.....	11
1.3.2	User manuals and help.....	12
1.3.3	Service manual.....	12
1.3.4	Instrument security procedures.....	12
1.3.5	Printed safety instructions.....	12
1.3.6	Data sheets and brochures.....	12
1.3.7	Release notes and open source acknowledgment (OSA).....	13
1.3.8	Application notes, application cards, white papers, etc.....	13
1.3.9	Videos.....	13
1.4	Scope.....	14
1.5	Notes on screenshots.....	14
<b>2</b>	<b>About the 3GPP FDD options.....</b>	<b>15</b>
2.1	Required options.....	15
2.2	Major 3GPP parameters overview.....	15
2.3	Modulation system 3GPP FDD.....	16
2.3.1	Scrambling code generator.....	17
2.3.2	Scrambling unit.....	20
2.3.3	Channelization code generator.....	21
2.3.4	Data source.....	21
2.3.5	Slot and frame builder.....	21
2.3.6	Timing offset.....	22
2.3.7	Demultiplexer.....	23
2.3.8	Power control.....	23
2.3.9	Summation and filtering.....	24
2.3.10	Multicode.....	24
2.3.11	Orthogonal channel noise (OCNS).....	25
2.3.12	HS-SCCH less operation.....	27

2.3.13	Higher order modulation.....	29
2.3.14	MIMO in HSPA+.....	30
2.3.15	Dual cell HSDPA (DC-HSDPA).....	36
2.3.16	HS-DPCCH extension for 4C-HSDPA and 8C-HSDPA.....	40
2.3.17	Dual cell HSUPA (Dual cell E-DCH).....	40
2.3.18	UE capabilities.....	40
2.3.19	Uplink discontinuous transmission (UL DTX).....	41
<b>3</b>	<b>3GPP FDD configuration and settings.....</b>	<b>44</b>
<b>3.1</b>	<b>General settings for 3GPP FDD signals.....</b>	<b>45</b>
<b>3.2</b>	<b>Trigger settings.....</b>	<b>47</b>
<b>3.3</b>	<b>Marker settings.....</b>	<b>52</b>
<b>3.4</b>	<b>Clock settings.....</b>	<b>54</b>
<b>3.5</b>	<b>Global connectors settings.....</b>	<b>55</b>
<b>3.6</b>	<b>Base stations and user equipment settings.....</b>	<b>56</b>
3.6.1	Common configuration settings.....	57
3.6.2	General power settings.....	59
<b>3.7</b>	<b>Test setups/models.....</b>	<b>62</b>
<b>3.8</b>	<b>Predefined settings - downlink.....</b>	<b>65</b>
<b>3.9</b>	<b>Additional user equipment - uplink.....</b>	<b>67</b>
<b>3.10</b>	<b>Base station settings.....</b>	<b>68</b>
3.10.1	Common settings.....	69
3.10.2	Orthogonal channel noise (OCNS) settings.....	71
3.10.3	Channel table.....	72
3.10.4	Channel graph - BS.....	78
3.10.5	Code domain graph - BS.....	79
<b>3.11</b>	<b>Compressed mode.....</b>	<b>82</b>
3.11.1	Compressed mode general settings.....	83
3.11.2	Compressed mode configuration graph.....	85
<b>3.12</b>	<b>HSDPA settings - BS.....</b>	<b>88</b>
3.12.1	Enhanced HSDPA mode settings.....	88
3.12.2	MIMO configuration.....	90
<b>3.13</b>	<b>HSDPA H-Set mode settings - BS.....</b>	<b>92</b>
3.13.1	HSDPA H-Set general settings.....	92

3.13.2	H-Set configuration common settings.....	93
3.13.3	MIMO settings.....	96
3.13.4	Global settings.....	97
3.13.5	Coding configuration.....	100
3.13.6	Signal structure.....	103
3.13.7	HARQ simulation.....	105
3.13.8	Error insertion.....	106
3.13.9	Randomly varying modulation and number of codes (Type 3i) settings.....	107
<b>3.14</b>	<b>Enhanced settings for P-CPICH - BS1.....</b>	<b>110</b>
<b>3.15</b>	<b>Enhanced settings for P-CCPCH - BS1.....</b>	<b>111</b>
3.15.1	Channel number and state.....	111
3.15.2	Channel coding - enhanced P-CCPCH BS1.....	112
<b>3.16</b>	<b>Enhanced settings for DPCHs - BS1.....</b>	<b>113</b>
3.16.1	Channel number and state.....	114
3.16.2	Channel coding.....	115
3.16.3	Transport channel - enhanced DPCHs BS1.....	118
3.16.4	Error insertion - enhanced DPCHs BS1.....	121
3.16.5	Dynamic power control - enhanced DPCHs BS1.....	123
<b>3.17</b>	<b>S-CCPCH settings - BS channel table.....</b>	<b>128</b>
<b>3.18</b>	<b>Config AICH/AP-AICH - BS channel table.....</b>	<b>130</b>
<b>3.19</b>	<b>DPCCH settings - BS channel table.....</b>	<b>131</b>
3.19.1	Common slot structure (DPCCH).....	131
3.19.2	TPC settings.....	134
3.19.3	DPCCH power offset.....	137
<b>3.20</b>	<b>Config E-AGCH - BS channel table.....</b>	<b>138</b>
<b>3.21</b>	<b>Config E-RGCH/E-HICH - BS channel table.....</b>	<b>140</b>
<b>3.22</b>	<b>Config F-DPCH - BS channel table.....</b>	<b>142</b>
3.22.1	Common settings.....	142
3.22.2	TPC settings.....	143
<b>3.23</b>	<b>Multi channel assistant - BS.....</b>	<b>146</b>
<b>3.24</b>	<b>User equipment configuration (UE).....</b>	<b>150</b>
3.24.1	General settings.....	151
3.24.2	Channel settings.....	153

<b>3.25</b>	<b>UL-DTX/user scheduling - UE</b> .....	<b>154</b>
<b>3.26</b>	<b>Dynamic power control - UE</b> .....	<b>157</b>
<b>3.27</b>	<b>Scheduling list</b> .....	<b>161</b>
<b>3.28</b>	<b>DPCCH settings - UE</b> .....	<b>162</b>
<b>3.29</b>	<b>DPDCH settings - UE</b> .....	<b>168</b>
3.29.1	DPDCH common settings.....	169
3.29.2	Channel table.....	171
<b>3.30</b>	<b>HS-DPCCH settings - UE</b> .....	<b>173</b>
3.30.1	About HS-DPCCH.....	174
3.30.2	HS-DPCCH common settings.....	176
3.30.3	HS-DPCCH scheduling table (Release 8 and later/RT).....	180
3.30.4	HS-DPCCH settings for normal operation (up to Release 7).....	189
3.30.5	MIMO settings HS-DPCCH (up to Release 7).....	191
<b>3.31</b>	<b>E-DPCCH settings - UE</b> .....	<b>194</b>
<b>3.32</b>	<b>HSUPA FRC settings - UE</b> .....	<b>196</b>
3.32.1	FRC general settings.....	196
3.32.2	Coding and physical channels settings.....	198
3.32.3	DTX mode settings.....	201
3.32.4	HARQ simulation settings.....	203
3.32.5	Bit and block error insertion settings.....	204
<b>3.33</b>	<b>E-DPDCH settings - UE</b> .....	<b>206</b>
3.33.1	E-DPDCH common settings.....	207
3.33.2	Channel table.....	208
<b>3.34</b>	<b>E-DCH scheduling - UE</b> .....	<b>209</b>
<b>3.35</b>	<b>Global enhanced channel settings - UE1</b> .....	<b>213</b>
3.35.1	Enhanced channels state.....	214
3.35.2	Channel coding.....	214
3.35.3	Transport channel.....	218
3.35.4	Error insertion.....	221
<b>3.36</b>	<b>PRACH settings - UE</b> .....	<b>222</b>
3.36.1	Graphical display.....	224
3.36.2	Preamble settings.....	228
3.36.3	Message part settings.....	229

3.36.4	Channel coding state.....	231
<b>3.37</b>	<b>PCPCH settings - UE.....</b>	<b>233</b>
3.37.1	Graphical display.....	235
3.37.2	Preamble settings.....	238
3.37.3	Message part settings.....	240
3.37.4	Channel coding settings.....	244
<b>3.38</b>	<b>Filtering, clipping, ARB settings.....</b>	<b>245</b>
3.38.1	Filter settings.....	246
3.38.2	Clipping settings.....	247
3.38.3	ARB settings.....	250
<b>4</b>	<b>How to work with the 3GPP FDD option.....</b>	<b>251</b>
4.1	Resolving domain conflicts.....	251
4.2	Using the DL-UL timing offset settings.....	254
4.3	Configuring UL-DTX transmission and visualizing the scheduling.....	254
4.4	How to configure the HS-DPCCH settings for 4C-HSDPA tests.....	256
<b>5</b>	<b>Remote-control commands.....</b>	<b>259</b>
5.1	General commands.....	260
5.2	Filter/clipping settings.....	266
5.3	Trigger settings.....	271
5.4	Marker settings.....	276
5.5	Clock settings.....	277
5.6	Test models and predefined settings.....	278
5.7	Setting base stations.....	282
5.8	Enhanced channels of base station 1.....	329
5.8.1	General settings.....	330
5.8.2	Channel coding.....	331
5.8.3	Dynamic power control settings.....	343
5.8.4	Error insertion.....	346
<b>5.9</b>	<b>User equipment settings.....</b>	<b>350</b>
5.9.1	General settings.....	351
5.9.2	Compressed mode settings.....	356
5.9.3	DPCCH settings.....	357
5.9.4	HS-DPCCH settings.....	364

5.9.5	DPDCH settings.....	382
5.9.6	PCPCH settings.....	386
5.9.7	PRACH settings.....	397
5.9.8	HSUPA settings.....	406
5.9.9	UL-DTX and uplink scheduling settings.....	423
5.9.10	Dynamic power control settings.....	427
<b>5.10</b>	<b>Enhanced channels of the user equipment.....</b>	<b>431</b>
	<b>Annex.....</b>	<b>444</b>
<b>A</b>	<b>Reference.....</b>	<b>444</b>
	<b>List of commands.....</b>	<b>451</b>
	<b>Index.....</b>	<b>461</b>



# 1 Welcome to the 3GPP FDD options

The R&S SMBV100B-K42/-K83 are firmware applications that add functionality to generate signals in accordance with the WCDMA standard 3GPP FDD.

WCDMA (Wideband CDMA) describes a group of mobile radiocommunication technologies, the details of which differ greatly. The R&S SMBV100B supports the 3GPP FDD standard developed by the 3GPP (3<sup>rd</sup> Generation Partnership Project) standardization committee.

The R&S SMBV100B generates the 3GPP FDD signals in a combination of realtime mode (enhanced channels) and arbitrary waveform mode. Channel coding and simulation of bit and block errors can be activated for the enhanced channels of Release 99 and for H-Sets 1 to 5 generated in real time. Channel coding can also be activated for HSDPA/HSPA+ H-Sets and all HSUPA/HSPA+ FRC channels which are generated in arbitrary wave mode. Data lists can also be used for the data and TPC fields. The enhanced state of realtime channels can be switched off to generate specific test scenarios. In arbitrary waveform mode, the signal is first calculated and then output.

The R&S SMBV100B simulates 3GPP FDD at the physical channel level and also at the transport layer level for all channels for which channel coding can be activated.

## 3GPP FDD/HSDPA/HSUPA/HSPA+ key features

- Support of all physical channels of 3GPP FDD, HSDPA, HSUPA and HSPA+
- HSDPA H-Sets 1 to 12 with channel coding; user-definable H-Set configuration
- HSUPA fixed reference channels with channel coding
- Realtime generation of P-CCPCH and up to three DPCHs in downlink
- One UE in real time in uplink, up to 128 additional mobile stations via ARB
- Dynamic power control of a code channel possible
- Support of UL-DTX, DC-HSDPA, 4C-HSDPA and 8C-HSDPA

## Functional overview of option R&S SMBVB-K42

The following list gives an overview of the functions provided by the option R&S SMBV100B-K42 for generating a 3GPP FDD signal:

- Configuration of up to four base stations and four user equipment.
- Combination of realtime mode (enhanced channels) and arbitrary waveform mode
- All special channels and up to 512 channels on the downlink, except HSDPA, HSUPA and HSPA+
- Various test models and pre-defined settings for the uplink and the downlink
- Modulation 16QAM and 64QAM (downlink) for configuring high-speed channels in continuous mode (test model 5&6, HSDPA)
- Clipping for reducing the crest factor
- Misuse TPC" parameter for varying the original normal transmit power over time
- Simulation of up to 128 additional user equipment

The following functions are provided specifically for the receiver test:

- Realtime generation of up to four code channels with the option of using data lists for the data and TPC fields
- Channel coding of the reference measurement channels, AMR and BCH in real time
- Feeding through of bit errors (to test a BER tester) and block errors (to test a BLER tester)
- Simulation of orthogonal channel noise (OCNS in accordance with TS 25.101)
- Presettings in accordance with 3GPP specifications
- HSDPA Downlink in continuous mode (test model 5&6 for TX tests)

### Functional overview of the extension R&S SMBVB-K83

Enhanced MS/BS tests incl. HSDPA extends the 3GPP FDD signal generation with simulation of high-speed channels in the downlink (HS-SCCH, HS-PDSCH) and the uplink (HS-DPCCH) and with dynamic power control. HSDPA (high speed downlink packet access) mode enhances the 3GPP FDD standard by data channels with high data rates especially for multi-media applications.

The following functions are provided for enhanced BS/MS tests including HSDPA:

- HSDPA uplink
- HSDPA downlink (packet mode and H-Set mode without CPC, 64QAM and MIMO)
- Dynamic Power Control
- Predefined and user-definable H-Sets
- Assistance in the setting of the appropriate sequence length for arbitrary waveform mode

HSUPA extends the 3GPP FDD signal generation with full HSUPA (high speed uplink packet access) support. Option K59 3GPP FDD HSPA+ extends the HSDPA and/or HSUPA signal generation with HSPA+ features in the downlink and uplink

The following functions are provided for HSUPA:

- HSUPA Downlink (RX measurements on 3GPP FDD UEs with correct timing )
- HSUPA Uplink (RX measurements on 3GPP FDD node BS supporting HSUPA)

The following functions are provided for HSPA+:

- Downlink 64QAM with channel coding
- Uplink 16QAM (4PAM)
- Downlink MIMO
- Uplink ACK/PCI/CQI feedback for downlink MIMO and/or Dual-Cell HSDPA
- CPC in downlink (HS-SCCH less operation, enhanced F-DPCH) and uplink (UL-DTX, Uplink DPCCH slot format 4)
- Support for the generation of 3i OCNS and for randomly varying modulation and the number of HS-PDSCH channels in H-Set over time (type 3i enhanced performance requirements tests).

This user manual contains a description of the functionality that the application provides, including remote control operation.

All functions not discussed in this manual are the same as in the base unit and are described in the R&S SMBV100B user manual. The latest version is available at:

[www.rohde-schwarz.com/manual/SMBV100B](http://www.rohde-schwarz.com/manual/SMBV100B)

### Installation

You can find detailed installation instructions in the delivery of the option or in the R&S SMBV100B service manual.

## 1.1 Accessing the 3GPP FDD dialog

### To open the dialog with 3GPP FDD settings

- ▶ In the block diagram of the R&S SMBV100B, select "Baseband > 3GPP FDD".

A dialog box opens that display the provided general settings.

The signal generation is not started immediately. To start signal generation with the default settings, select "State > On".

## 1.2 What's new

This manual describes firmware version FW 5.30.047.xx and later of the R&S®SMBV100B.

Compared to the previous version, it provides the new features listed below:

- Time-based triggering, see "[Time Based Trigger](#)" on page 50 and "[Trigger Time](#)" on page 50.
- Editorial changes

## 1.3 Documentation overview

This section provides an overview of the R&S SMBV100B user documentation. Unless specified otherwise, you find the documents at:

[www.rohde-schwarz.com/manual/smbv100b](http://www.rohde-schwarz.com/manual/smbv100b)

### 1.3.1 Getting started manual

Introduces the R&S SMBV100B and describes how to set up and start working with the product. Includes basic operations, typical measurement examples, and general information, e.g. safety instructions, etc. A printed version is delivered with the instrument.

### 1.3.2 User manuals and help

Separate manuals for the base unit and the software options are provided for download:

- **Base unit manual**  
Contains the description of all instrument modes and functions. It also provides an introduction to remote control, a complete description of the remote control commands with programming examples, and information on maintenance, instrument interfaces and error messages. Includes the contents of the getting started manual.
- **Software option manual**  
Contains the description of the specific functions of an option. Basic information on operating the R&S SMBV100B is not included.

The contents of the user manuals are available as help in the R&S SMBV100B. The help offers quick, context-sensitive access to the complete information for the base unit and the software options.

All user manuals are also available for download or for immediate display on the Internet.

### 1.3.3 Service manual

Describes the performance test for checking compliance with rated specifications, firmware update, troubleshooting, adjustments, installing options and maintenance.

The service manual is available for registered users on the global Rohde & Schwarz information system (GLORIS):

<https://gloris.rohde-schwarz.com>

### 1.3.4 Instrument security procedures

Deals with security issues when working with the R&S SMBV100B in secure areas. It is available for download on the internet.

### 1.3.5 Printed safety instructions

Provides safety information in many languages. The printed document is delivered with the product.

### 1.3.6 Data sheets and brochures

The data sheet contains the technical specifications of the R&S SMBV100B. It also lists the options and their order numbers and optional accessories.

The brochure provides an overview of the instrument and deals with the specific characteristics.

See [www.rohde-schwarz.com/brochure-datasheet/smbv100b](http://www.rohde-schwarz.com/brochure-datasheet/smbv100b)

### 1.3.7 Release notes and open source acknowledgment (OSA)

The release notes list new features, improvements and known issues of the current firmware version, and describe the firmware installation.

The software makes use of several valuable open source software packages. An open-source acknowledgment document provides verbatim license texts of the used open source software.

See [www.rohde-schwarz.com/firmware/smbv100b](http://www.rohde-schwarz.com/firmware/smbv100b)

### 1.3.8 Application notes, application cards, white papers, etc.

These documents deal with special applications or background information on particular topics.

See [www.rohde-schwarz.com/application/smbv100b](http://www.rohde-schwarz.com/application/smbv100b)

### 1.3.9 Videos

Find various videos on Rohde & Schwarz products and test and measurement topics on YouTube: <https://www.youtube.com/@RohdeundSchwarz>



On the menu bar, search for your product to find related videos.

HOME VIDEOS SHORTS PLAYLISTS COMMUNITY CHANNELS ABOUT

*Figure 1-1: Product search on YouTube*

## 1.4 Scope



Tasks (in manual or remote operation) that are also performed in the base unit in the same way are not described here.

In particular, it includes:

- Managing settings and data lists, like saving and loading settings, creating and accessing data lists, or accessing files in a particular directory.
- Information on regular trigger, marker and clock signals and filter settings, if appropriate.
- General instrument configuration, such as checking the system configuration, configuring networks and remote operation
- Using the common status registers

For a description of such tasks, see the R&S SMBV100B user manual.

## 1.5 Notes on screenshots

When describing the functions of the product, we use sample screenshots. These screenshots are meant to illustrate as many as possible of the provided functions and possible interdependencies between parameters. The shown values may not represent realistic usage scenarios.

The screenshots usually show a fully equipped product, that is: with all options installed. Thus, some functions shown in the screenshots may not be available in your particular product configuration.

## 2 About the 3GPP FDD options

Some background knowledge on basic terms and principles used in the 3GPP FDD modulation system is provided here for better understanding of the required configuration settings.

### 2.1 Required options

The basic equipment layout for generating 3GPP FDD signals includes the:

- Base unit
- Baseband realtime extension (R&S SMBVB-K520)
- Digital standard 3GPP FDD (R&S SMBVB-K42)

The following options are required to **support all 3GPP-related settings** described in this user manual:

- Option digital standard 3GPP FDD (R&S SMBVB-K42)
- Option 3GPP FDD HSPA/HSPA+, Enhanced BS/MS Tests (R&S SMBVB-K83)

For more information, see data sheet.

### 2.2 Major 3GPP parameters overview

[Table 2-1](#) gives an overview of parameters of the modulation system 3GPP FDD.

Table 2-1: Parameters of the modulation system

Parameter	Value
Chip rate	3.84 Mcps
Channel types	Downlink: <ul style="list-style-type: none"> <li>• Primary Common Pilot Channel (P-CPICH)</li> <li>• Secondary Common Pilot Channel (S-CPICH)</li> <li>• Primary Sync Channel (P-SCH)</li> <li>• Secondary Sync Channel (S-SCH)</li> <li>• Primary Common Control Phys. Channel (P-CCPCH)</li> <li>• Secondary Common Control Phys. Channel (S-CCPCH)</li> <li>• Page Indication Channel (PICH)</li> <li>• Acquisition Indication Channel (AICH)</li> <li>• Access Preamble Acquisition Indication Channel (AP-AICH)</li> <li>• Collision Detection Acquisition Indication Channel (CD-AICH)</li> <li>• Phys. Downlink Shared Channel (PDSCH)</li> <li>• Dedicated Physical Control Channel (DL-DPCCH)</li> <li>• Dedicated Phys. Channel (DPCH)</li> <li>• High-Speed Shared Control Channel (HS-SCCH)</li> <li>• High-Speed Physical Downlink Shared Channel (HS-PDSCH), Modulation QPSK, 16 QAM or 64QAM</li> <li>• HSUPA channels (E-AGCH, E-RGCH, E-HICH, F-DPCH)</li> </ul> Uplink: <ul style="list-style-type: none"> <li>• Phys. Random Access Channel (PRACH)</li> <li>• Phys. Common Packet Channel (PCPCH)</li> <li>• Dedicated Physical Control Channel (DPCCH)</li> <li>• Dedicated Physical Data Channel (DPDCH)</li> <li>• High Speed Dedicated Physical Control Channel (HS-DPCCH)</li> <li>• E-DCH Dedicated Physical Control Channel (E-DPCCH)</li> <li>• E-DCH dedicated physical data channel (E-DPDCH)</li> </ul>
Symbol rates	7.5 ksps, 15 ksps, 30 ksps to 960 ksps depending on the channel type (downlink) 15 ksps, 30 ksps, 60 ksps to 1920 ksps depending on the channel type (uplink)
Channel count	In downlink 4 base stations each with up to 128 DPCHs and 11 special channels. In uplink 4 user equipment either with PRACH or PCPCH or a combination of DPCCH, up to 6 DPDCH, HS-DPCCH, E-DPCCH and up to 4 E-DPDCH channels.
Frame structure	Timeslot: 0.667 ms, Subframe: 3 timeslots = 2 ms Radio frame: 15 timeslots = 10 ms The frame structure in symbols depends on the symbol rate.
Scrambling code	Downlink: 18-bit M sequence Uplink: 25-bit M sequence in long mode and 8-bit M sequence in short mode
Channelization code for most of the channel types	"Orthogonal Variable Spreading Factor Code (OVSF)" square matrix of dimension chip rate/symbol rate

## 2.3 Modulation system 3GPP FDD

The following block diagram shows the components of the 3GPP FDD transmission system.



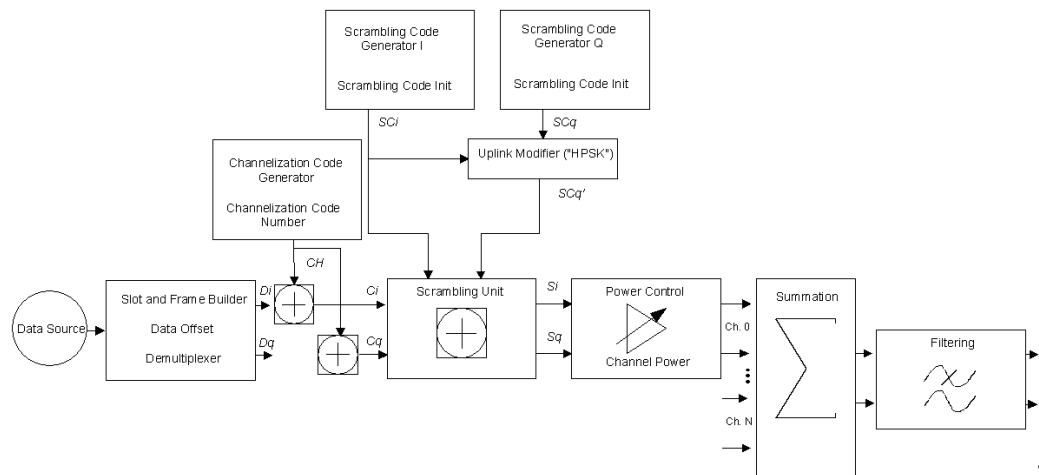

Figure 2-1: Components of the 3GPP FDD transmission system

## 2.3.1 Scrambling code generator

The scrambling code generator (previously called long code generator) is used to scramble the chip sequence as a function of the transmitter.

Depending on the link direction and mode (long or short), the structure and initialization regulation of the generator are different.

### 2.3.1.1 Downlink scrambling code generator

This generator consists of a pair of shift registers from which the binary sequences for in-phase and orthogonal component of the scrambling code are determined. The [Figure 2-2](#) shows that the I component is produced as EXOR operation of the LSB outputs. However the register contents are first masked and read out for the Q component and then EXORed.

Table 2-2: Generator polynomials of the downlink scrambling code generators

Shift register 1	$x^{18}+x^7+1$
Shift register 2	$x^{18}+x^{10}+x^7+x^5+1$

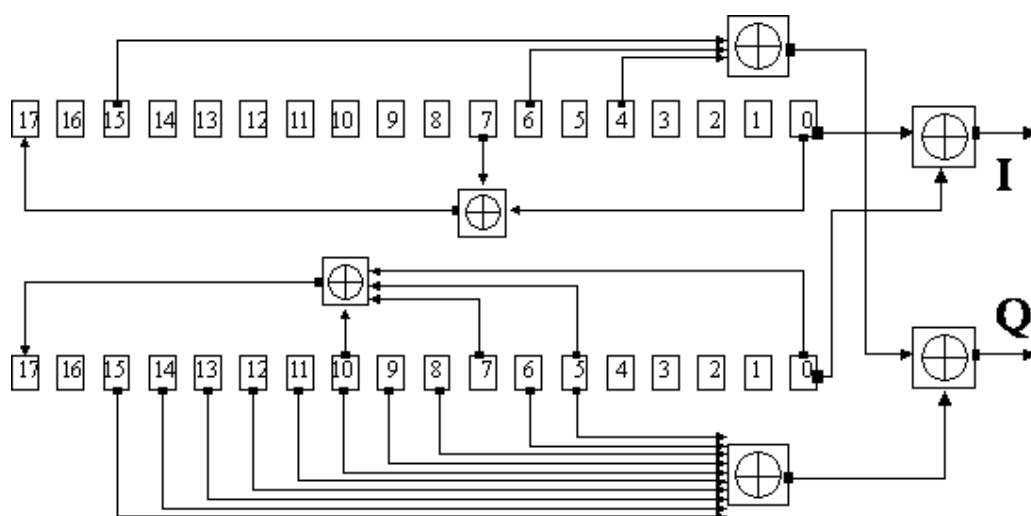

Figure 2-2: Structure of downlink scrambling code generator

The shift registers are initialized by loading shift register 1 with "0...01" and shift register 2 completely with "1". In addition, shift register 1 is wound forward by  $n$  cycles,  $n$  being the scrambling code number or scrambling code (SC) for short.

After a cycle time of one radio frame the generators are reset, i.e. the above initialization is carried out again.

### 2.3.1.2 Uplink scrambling code generator

In the uplink, a differentiation is made between two SC modes. The long SC can be used for all types of channel. The short SC can be used as an alternative to the long SC for all channels except PRACH and PCPCH.

#### Uplink long scrambling code

Principally, the code generator of the long SC in the uplink is of the same structure as the SC in the downlink. However, the generator polynomials of the shift registers and the type of initialization are different.

Table 2-3: Generator polynomials of the uplink long scrambling code generator

Shift register 1	$x^{25}+x^3+1$
Shift register 2	$x^{25}+x^3+x^2+x+1$

The shift registers are initialized by allocating 1 to shift register 1-bit number 24 and the binary form of the scrambling code number  $n$  to bits 23 to 0. Shift register 2 is loaded with "1".

The read-out positions for the Q component are defined such that they correspond to an IQ offset of 16.777.232 cycles.

After a cycle time of one radio frame the generators are reset, i.e. the above initialization is carried out again.

### Uplink short scrambling code

The code generator of the short SC in the uplink consists of a total of three coupled shift registers.

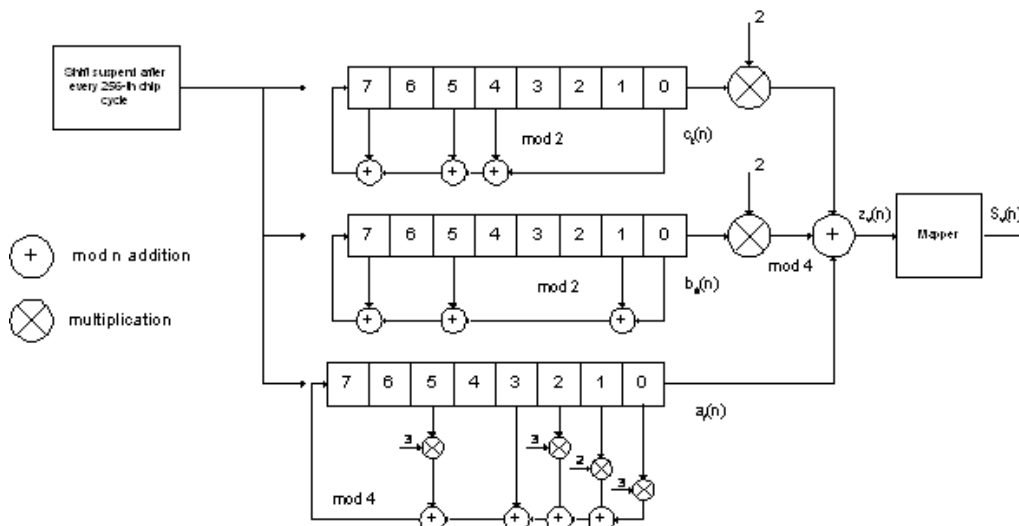

Figure 2-3: Structure of uplink short scrambling code generator

Table 2-4: Generator polynomials of uplink short scrambling code generator

Shift register 1 (binary)	$x^8+x^7+x^5+x^4+1$
Shift register 2 (binary)	$x^8+x^7+x^5+x+1$
Shift register 3 (quaternary)	$x^8+x^5+3x^3+x^2+2x+1$

The output sequences of the two binary shift registers are weighted with factor 2 and added to the output sequence of the quaternary shift register. The resulting quaternary output sequence is mapped into the binary complex level by the mapper block.

For initialization, of the three 8-bit shift registers (in a modified way) the binary form of the 24-bit short SC number  $n$  is used. For details see 3GPP TS 25 213, "Spreading and Modulation".

Table 2-5: Mapping of the quaternary output sequence into the binary IQ level

z <sub>v</sub> (n)	S <sub>v</sub> (n)
0	+1 + j1
1	-1 + j1
2	-1 - j1
3	+1 - j1

### Preamble scrambling code generator

When generating the preambles of the PRACH and PCPCH, a special SC is used. It is based on the Long SC described under a), however only the I component is taken and subsequently a pointer ( $e^{j(\pi/4 + \pi/4 * k)}$ ,  $k=0$  to 4095) modulated upon it.

### Modification of the long and short scrambling code output sequence

The scrambling code sequence of the Q component is modified as standard to reduce the crest factor of the signal. Zero-crossings can thus be avoided for every second cycle. (This method is often called "HPSK").

For details see 3GPP TS 25 213, "Spreading and Modulation". The R&S SMBV100B uses a decimation factor of 2.

### 2.3.2 Scrambling unit

In the scrambling unit, the output of the scrambling code generator is linked with spread symbols.

The input signal and the scrambling code signal are interpreted as complex signal:

$$(C_i, C_q, SC_i, SC_q' \in \{-1, +1\})$$

The output signal is a complex multiplication of two signals:

$$S_i + j S_q = (C_i + j C_q) * (SC_i + j SC_q')$$

The following equations apply:

$$S_i = C_i SC_i - C_q SC_q'$$

$$S_q = C_i SC_q' + C_q SC_i$$

The signal thus obtained can be interpreted as a QPSK signal with the following constellation diagram:

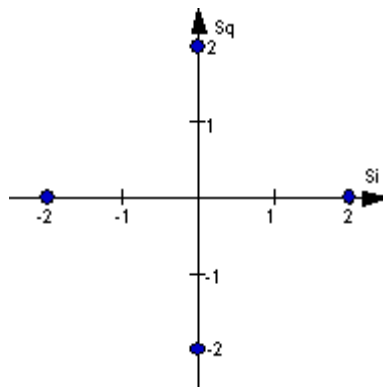

Figure 2-4: Constellation diagram of a channel with 0 dB power



There are auxiliary conditions for some types of channels that can result in different constellation diagrams. If, for instance, symbols of the SCH are coded, a BPSK constellation is obtained without the scrambling unit.

Furthermore, with HSDPA and HSPA+, the higher order modulations 4PAM, 16QAM and 64QAM were introduced.

### 2.3.3 Channelization code generator

The channelization code generator cyclically outputs a channel-specific bit pattern. The length of the cycle corresponds to the period of the source symbol to be spread, i.e. the number of bits corresponds to the spread factor. The spreading sequence for the I and Q branch is identical (real value). Spreading is a simple EXOR operation.

Two different channelization code generators are used depending on the type of channel:

#### Channelization code generator for all channels except SCH

Due to this channelization code, the channel separation takes place in the sum signal. The channelization code number is the line of an orthogonal spreading matrix which is generated according to an iterative scheme ("OVSF").

#### Channelization code generator SCH

This generator replaces the one described above if the synchronization code symbol of the SCH channels is spread.

The spreading matrix is replaced by a method that forms the spreading sequence. For details, see 3GPP TS 25 213.

### 2.3.4 Data source

The data and TPC fields of the enhanced channels (realtime channels) can be filled from data lists containing user-defined data. This allows user information from the physical layer or from higher layers such as the transport layer to be introduced into the signal generation process.

The choice of data sources is crucially important for the signal characteristics. The constellation diagram and the crest factor in particular are modeled to a great extent by a suitable choice of data.

### 2.3.5 Slot and frame builder

The bits from the data source are first entered into a frame structure. The frames are made up of three hierarchical levels:

*Table 2-6: Hierarchical structure of 3GPP FDD frames*

Hierarchy	Length in ms	Remarks
Timeslot	0.667	
Subframe	2 ms	One subframe consists of 3 timeslots.
Radio frame	10	After a radio frame, pilot symbols are repeated. One radio frame consists of 15 timeslots. A frame is also the length of a scrambling code cycle. Frames are the basic unit. The sequence length is stated in radio frames.

The configuration of the timeslots depends on the channel type and symbol rate. The following components are distinguished:

- **Pilot sequence**  
The pilot sequence characterizes the timeslot position within the radio frame and also depends on the symbol rate, transmit diversity and the pilot length parameter. Channel types DPCH, S-CCPCH, DL-DPCCH, DPCCH, PRACH and PCPCH have a pilot sequence.
- **Synchronization code symbol**  
The synchronization code symbol is the only symbol of the SCH.
- **TPC symbol**  
This symbol is used to control the transmit power. It is used in DPCH, DL-DPCCH and DPCCH.  
A bit pattern for the sequence of TPC symbols can be indicated as a channel-specific pattern.
- **Data symbols**  
These symbols carry the user information and are fed from the data source. They are used in DPCH, P-CCPCH, S-CCPCH, PDSCH, E-AGCH, E-RGCH, E-HICH, DPDCH, PRACH, PCPCH, HS-PDSCH and E-DPDCH.
- **Signature**  
The signature is used in PRACH and PCPCH. 16 fixed bit patterns are defined.
- **TFCI (transport format combination indicator)**  
If enabled, the TFCI is used in DPCH/DPCCH. In this case, a code sequence with the length of 30 is defined using this value and distributed among 15 subsequent timeslots. In PRACH and PCPCH, the TFCI field is provided as standard.
- **FBI**  
Feedback indication bits are only used in DPCCH and PCPCH.

### 2.3.6 Timing offset

The symbol stream can be shifted in time relative to the other channels. For this purpose, a timing offset can be entered into the channel table, stating the range of shifting in multiples of 256 chips. Since the generator does not generate infinite symbol streams like a real-time system, this offset is implemented as a rotation.

#### Example:

DPCH 30 ksps, 1 timeslot, timing offset = 2;

$2 \times 256$  chips = 512 chip offset;

4 data symbols shifting at a symbol rate of 30 ksps (1 symbol corresponds to 3.84 Mcps / 30 ksps = 128 chips).

Previously:

11	11	11	11	00	01	10	11	00	10	01	11	11	01	00	01	10	11	01	00
----	----	----	----	----	----	----	----	----	----	----	----	----	----	----	----	----	----	----	----

Afterwards:

10	11	01	00	11	11	11	11	00	01	10	11	00	10	01	11	11	01	00	01
----	----	----	----	----	----	----	----	----	----	----	----	----	----	----	----	----	----	----	----

The use of the timing offset usually causes a reduction of the crest factor of the total signal. This is based on the fact that the spreading chips  $CH$  and scramble chips  $SC_i/SC_q$  that are applied to the pilot sequences of the channels are not always the same.

### 2.3.7 Demultiplexer

In the downlink, the symbol stream is divided into 2-bit streams  $D_i$  and  $D_q$  before processing in the spreading unit.

For example, if QPSK modulation is used for a channel, the symbol stream is processed as follows:

- It is divided by allocating bits 1, 3, 5, to  $2n-1$  to the in-phase bitstream  $D_i$
- It is divided by allocating bits 2, 4, 6,  $2n$  to the quadrature bitstream  $D_q$ .

For the above example with timing offset:

$D_i = 1\ 1\ 0\ 0\ 1\ 1\ 1\ 1\ 0\ 0\ 1\ 1\ 0\ 1\ 0\ 1\ 1\ 0\ 0\ 0$

$D_q = 0\ 1\ 1\ 0\ 1\ 1\ 1\ 1\ 0\ 1\ 0\ 1\ 0\ 0\ 1\ 1\ 1\ 1\ 0\ 1$

(left-hand bit is always the first one in the time sequence)

In the uplink, independent data are used for the two paths.

PRACH/PCPCH:	Preamble : signature parallel to I and Q
	Message part : data to I, pilot, TPC and TFCI to Q
DPCCH/E-DPCCH:	all bits to I, Q always unused
DPDCH/HS-DPCCH/E-DPDCH:	all bits are always to I or Q (dependent on channel number), the other path is unused.

### 2.3.8 Power control

After spreading and scrambling, a channel-specific power factor  $p$  is applied to the signal. A value of -6 dB therefore results in half the level (or  $\frac{1}{4}$  power) and the following diagram (DPCH):

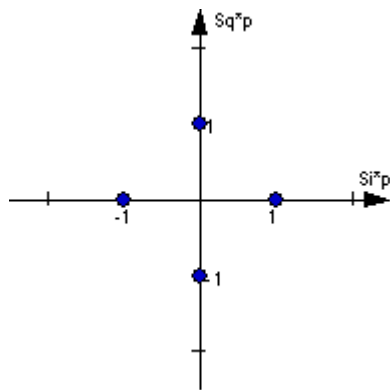

Figure 2-5: Constellation diagram of a channel with  $-6$  dB power

### 2.3.9 Summation and filtering

After application of the channel power, the components of the individual channels are summed up.

The constellation diagram of the sum signal is obtained by superposition of the diagrams of the individual channels. If the signal consists of two channels with power of  $-6$  dB and  $-12$  dB and each channel contains independent source data (DPCH), the following constellation diagram is obtained:

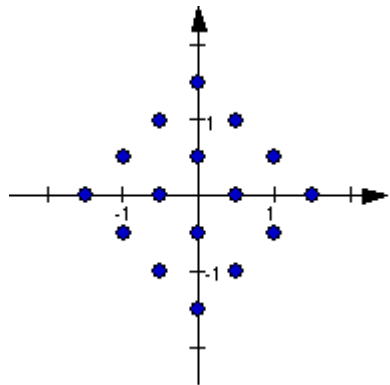

Figure 2-6: Constellation diagram of a 3GPP WCDMA signal with two DPCH channels

### 2.3.10 Multicode

3GPP FDD supports multicode transmission for downlink-dedicated physical channels (DPCH).

This form of transmission is used for channels intended for the same receiver, i.e. those receivers that belong to a radio link. The first channel of this group is used as a master channel.

Shared parts (pilot, TPC and TCFI) are spread for all channels using the spreading code of the master channel.





Instead of changing the spreading code within a slot several times, the master code rather than the shared parts can be sent at higher power. Then blank out the other channels correspondingly.

### 2.3.11 Orthogonal channel noise (OCNS)

With orthogonal channel noise, a practical downlink signal is generated to test the maximum input levels of user equipment in accordance with standard specifications. This simulates the data and control signals of the other orthogonal channels in the downlink. 3GPP TS 25.101 contains a precise definition of the required appearance of the OCNS signal.

Four different OCNS scenarios are defined in the standard. One standard scenario, two scenarios for HSDPA test cases and one scenario for type 3i enhanced performance requirements tests according to 3GPP TS34.121-1.

When activating OCNS and depending on the selected OCNS mode, different channel groups with different presetting are assigned as in the following tables. These channels cannot be edited in the channel table.

#### 2.3.11.1 Standard, HSDPA and HSDPA2 modes

For the "Standard", "HSDPA" and "HSDPA2" modes, the OCNS channels are all normal DPCHs. The symbol rate is set at 30 ksps and the pilot length to 8 bits.

The powers of the OCNS channel outputs are relative. In the R&S SMBV100B, the power of the OCNS component is set so that OCNS channels supplement the remaining channels in BS1 to make total power of 0 dB (linear 1).

It is not possible to adapt the OCNS power if the linear power of the remaining channels is >1, this produces an error message. The OCNS channels are then given the maximum power (all -80 dB).

The "Total Power" display is updated after automatic calculation of the output; it is not possible to use "Adjust Total Power" to make the setting.

**Table 2-7: Defined settings for the OCNS signal in base station 1 in Standard mode**

Chan. code	Timing offset (x256Tchip)	Level setting (dB)	Channel type	Symbol rate	Pilot length
2	86	-1	DPCH	30 ksps	8 bit
11	134	-3	DPCH	30 ksps	8 bit
17	52	-3	DPCH	30 ksps	8 bit
23	45	-5	DPCH	30 ksps	8 bit
31	143	-2	DPCH	30 ksps	8 bit
38	112	-4	DPCH	30 ksps	8 bit
47	59	-8	DPCH	30 ksps	8 bit
55	23	-7	DPCH	30 ksps	8 bit

Chan. code	Timing offset (x256Tchip)	Level setting (dB)	Channel type	Symbol rate	Pilot length
62	1	-4	DPCH	30 ksps	8 bit
69	88	-6	DPCH	30 ksps	8 bit
78	30	-5	DPCH	30 ksps	8 bit
85	18	-9	DPCH	30 ksps	8 bit
94	30	-10	DPCH	30 ksps	8 bit
125	61	-8	DPCH	30 ksps	8 bit
113	128	-6	DPCH	30 ksps	8 bit
119	143	0	DPCH	30 ksps	8 bit

**Table 2-8: Defined settings for the OCNS signal in base station 1 in HSDPA mode**

Channelization code at SF=128	Relative Level setting (dB)	Channel type	Symbol rate	Pilot length
122	0	DPCH	30 ksps	8 bit
123	-2	DPCH	30 ksps	8 bit
124	-2	DPCH	30 ksps	8 bit
125	-4	DPCH	30 ksps	8 bit
126	-1	DPCH	30 ksps	8 bit
127	-3	DPCH	30 ksps	8 bit

**Table 2-9: Defined settings for the OCNS signal in base station 1 in HSDPA2 mode**

Channelization code at SF=128	Relative Level setting (dB)	Channel type	Symbol rate	Pilot length
4	0	DPCH	30 ksps	8 bit
5	-2	DPCH	30 ksps	8 bit
6	-4	DPCH	30 ksps	8 bit
7	-1	DPCH	30 ksps	8 bit

### 2.3.11.2 3i OCNS mode

Option: R&S SMBVB-K83

In the "3i" OCNS mode, 16 DPCH channels are inserted in the BS 1 channel according to 3GPP TS34.121-1, chapter E.5E.

According to 3GPP TS34.121-1, table E.5E.1.3, the channelization code of each of these channels changes randomly on a symbol-by-symbol basis between two possible values.

The power control sequence modeling according to 3GPP TS34.121-1, chapter E.5E.3 is applied to these channels. The power relationship between these channels is

according to 3GPP TS34.121-1, table E.5E.1.3 only during the first slot. It can deviate in the subsequent slots up to a certain range, but the total power of these channels is maintained constant (by normalization).



If the "3i" OCNS mode is activated, the OCNS channels are automatically leveled to have total power of 0 dB for all channels of BS 1.

**Table 2-10: Defined settings for the OCNS signal in base station 1 in 3i mode**

Slot format	Symbol Rate, kbps	First Ch. code of the channel	Second Ch. code of the channel	Relative Power, dB (before the 0 dB adjustment)
10	30	2	108	-1.7
10	30	3	103	-2.7
10	30	5	109	-3.5
10	30	6	118	-0.8
10	30	90	4	-6.2
10	30	94	123	-4.6
10	30	96	111	-2.3
10	30	98	106	-4.1
10	30	99	100	-3.1
10	30	101	113	-5.1
12	60	52	44	0.0
10	30	110	124	-4.6
10	30	114	115	-4.8
10	30	116	126	-4.8
12	60	60	46	-1.1
10	30	125	95	-4.1



Refer to [Chapter 3.13.9, "Randomly varying modulation and number of codes \(Type 3i\) settings"](#), on page 107 for description of the further settings required for the 3i enhanced performance requirements tests according to 3GPP TS 34.121-1.

### 2.3.12 HS-SCCH less operation

HS-SCCH less operation is a special HSDPA mode of operation which reduces the HS-SCCH overhead and reduces UE battery consumption. It changes the conventional structure of HSDPA data reception. In HSDPA as defined from 3GPP release 5 onwards, UE is supposed to read continuously HS-SCCH where data allocations are being signaled. The UE is being addressed via a UE-specific identity (16-bit H-RNTI /

HSDPA radio network temporary identifier) on HS-SCCH. As soon as the UE detects relevant control information on HS-SCCH, it switches to the associated HS-PDSCH resources and receives the data packet.

This scheme is fundamentally changed in HS-SCCH less operation and HS-SCCH less operation is optimized for services with relatively small packets, e.g. VoIP.

In HS-SCCH less operation mode, the base station can decide for each packet again whether to apply HS-SCCH less operation or not, i.e. conventional operation is always possible.

The first transmission of a data packet on HS-DSCH is done without an associated HS-SCCH. The first transmission always uses QPSK and redundancy version of 0. Only four pre-defined transport formats can be used so the UE can blindly detect the correct format. The four possible transport formats are configured by higher layers. Only pre-defined channelization codes can be used for this operation mode and are configured per UE by higher layers: the parameter HS-PDSCH code index provides the index of the first HS-PDSCH code to use. For each of the transport formats, it is configured whether one or two channelization codes are required.

In order to allow detection of the packets on HS-DSCH, the HS-DSCH CRC (Cyclic Redundancy Check) becomes UE specific based on the 16-bit HRNTI. This is called CRC attachment method 2 (CRC attachment method 1 is conventional as of 3GPP release 5).

In case of successful reception of the packet, the UE sends an ACK on HS-DPCCH. If the packet was not received correctly, the UE sends nothing.

If the packet is not received in the initial transmission, the base station retransmits it. The number of retransmissions is limited to two in HS-SCCH less operation.

In contrast to the initial transmission, the retransmissions are using HS-SCCH signaling. However, the coding of the HS-SCCH deviates from release 5, since the bits on HS-SCCH are reinterpreted. This is called HS-SCCH type 2. The conventional HS-SCCH as of 3GPP release 5 is called HS-SCCH type 1.

### 2.3.12.1 HS-SCCH type 2

The table below gives a comparison of the HS-SCCH Type 1 (normal operation) and HS-SCCH Type 2 (less operation) formats.

**Table 2-11: Comparison of HS-SCCH Type 1 and Type 2**

HS-SCCH Type 1 (normal operation)	HS-SCCH Type 2 (less operation)
Channelization code set information (7 bits)	Channelization code set information (7 bits)
Modulation scheme information (1 bit)	Modulation scheme information (1 bit)
Transport block size information (6 bits)	Special information type (6 bits)
HARQ process information (3 bits)	Special information (7 bits)
Redundancy and constellation version (3 bits)	UE identity (16 bits)
New data indicator (1 bit)	
UE identity (16 bits)	

The special information type on HS-SCCH type 2 must be set to 111110 to indicate HS-SCCH less operation. The 7 bits special information then contains:

- 2-bit transport block size information (one of the four possible transport block sizes as configured by higher layers)
- 3-bit pointer to the previous transmission of the same transport block (to allow soft combining with the initial transmission)
- 1-bit indicator for the second or third transmission
- 1 bit reserved.

QPSK is also used for the retransmissions. The redundancy version for the second and third transmissions are equal to 3 and 4, respectively.

For the retransmissions, also HS-DSCH CRC attachment method 2 is used.

ACK or NACK is reported by the UE for the retransmitted packets.

#### 2.3.12.2 HS-SCCH type two fixed reference channel: H-Set 7

In order to support HS-SCCH Type 2 (less operation) testing, a fixed reference channel has been introduced. H-Set 7 is specified as reference test channel for HSDPA test cases.

The H-Set 7 consists of one HS-PDSCH and its parameterization and coding chain is based on one code with QPSK modulation and one HARQ process.

### 2.3.13 Higher order modulation

#### 2.3.13.1 64QAM in downlink

With the possibility to use 64QAM in downlink, HSPA+ can achieve downlink data rates of 21 Mbps. This theoretical peak data rate (physical channel bit rate) with 64QAM is calculated as follows:

$$\text{Peak data rate (64QAM)} = 15 [\text{codes}] * 2880 \text{ bits} / 2 \text{ ms [subframe]} = 21.6 \text{ MBps}$$

#### 2.3.13.2 64QAM fixed reference channel: H-Set 8

In order to support 64QAM testing, a fixed reference channel has been introduced. H-Set 8 is specified as reference test channel for HSPA+ test cases.

The H-Set 8 parameterization and coding chain is based on 15 codes with 64QAM modulation. Six hybrid ARQ processes are used, and HS-DSCH is continuously transmitted.

### 2.3.13.3 16QAM in uplink

With the possibility to use 16QAM on E-DCH (enhanced dedicated channel) in uplink, HSPA+ can achieve uplink peak data rates of 11.5 Mbps. A new uplink UE category 7 has been introduced which supports 16QAM in addition to BSPK.

Uplink transmission in HSPA+ is based on IQ multiplexing of E-DPDCH (enhanced dedicated physical data channel) physical channels as in HSUPA of 3GPP release 6. In fact, the 16QAM constellation is made up of two orthogonal 4PAM (pulse amplitude modulation) constellations. In case of 4PAM modulation, a set of two consecutive binary symbols  $n_k$  and  $n_{k+1}$  is converted to a real valued sequence following the mapping described in the table below.

**Table 2-12: Mapping of E-DPDCH with 4PAM modulation**

$n_k, n_{k+1}$	00	01	10	11
Mapped real value	0.4472	1.3416	-0.4477	-1.3416

This results in the following symbol mapping:



An E-DPDCH uses BPSK or 4PAM modulation symbols.

### 2.3.13.4 16QAM fixed reference channel: FRC 8

To support 16QAM (4PAM) testing in the uplink, an E-DPDCH fixed reference channel (FRC 8) has been introduced.

The FRC 8 parameterization and channel coding is based on the following:

- Four physical channel codes (2xSF2 and 2xSF4) with overall symbol rate of 2x960 + 2x1920 ksps
- 4PAM modulation
- E-DCH TTI of 2 ms
- Eight hybrid ARQ processes

### 2.3.14 MIMO in HSPA+

HSPA+ uses full MIMO approach including spatial multiplexing. The approach is called D-TxAA (double transmit antenna array). It is only applicable for the high-speed downlink shared channel, the HS-DSCH.

The figure below shows the basic principle of the 2x2 approach. The figure is taken from 3GPP TS 25.214.

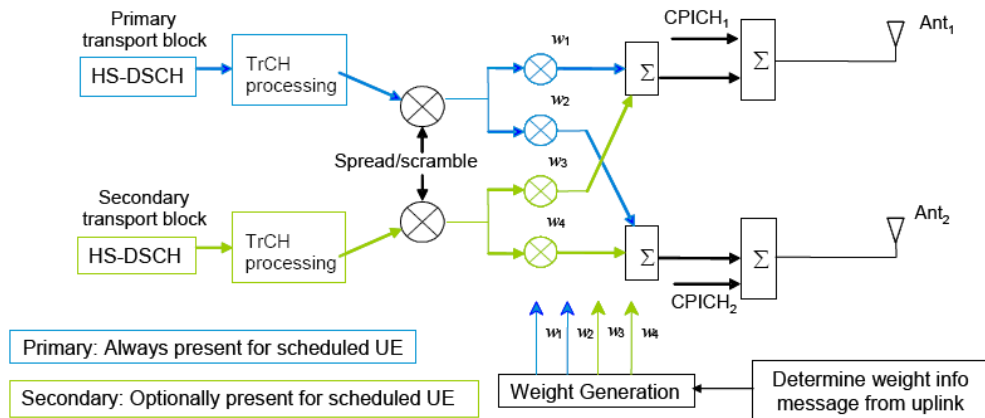

Figure 2-7: MIMO for HSPA+

With D-TxAA, two independent data streams (transport blocks) can be transmitted simultaneously over the radio channel over the same WCDMA channelization codes. Each transport block is processed and channel coded separately. After spreading and scrambling, **precoding** based on weight factors is applied to optimize the signal for transmission over the mobile radio channel.

Four precoding weights  $w_1$  -  $w_4$  are available. The first stream is multiplied with  $w_1$  and  $w_2$ , the second stream is multiplied with  $w_3$  and  $w_4$ . The weights can take the following values:

$$w_3 = w_1 = 1/\sqrt{2},$$

$$w_4 = -w_2,$$

$$w_2 \in \left\{ \frac{1+j}{2}, \frac{1-j}{2}, \frac{-1+j}{2}, \frac{-1-j}{2} \right\}$$

Precoding weight  $w_1$  is always fixed, and only  $w_2$  can be selected by the base station. Weights  $w_3$  and  $w_4$  are automatically derived from  $w_1$  and  $w_2$ , because they have to be orthogonal.

### 2.3.14.1 D-TxAA feedback signaling: PCI and CQI

D-TxAA requires a **feedback signaling** from the UE to assist the base station in taking the right decision in terms of modulation and coding scheme and precoding weight selection. The UE has to determine the preferred primary precoding vector for transport block 1 consisting of  $w_1$  and  $w_2$ . Since  $w_1$  is fixed, the feedback message only consists of a proposed value for  $w_2$ . This feedback is called **precoding control information (PCI)**. The UE also recommends whether one or two streams can be supported in the current channel situation. If dual stream transmission is used, the secondary precoding vector consists of the weights  $w_3$  and  $w_4$ . It is inferred in the base station, because it has to be orthogonal to the first precoding vector with  $w_1$  and  $w_2$ . Thus, the UE does not have to report it explicitly. The UE also indicates the optimum modulation and coding scheme for each stream. This report is called **channel quality indicator (CQI)**.

Based on the composite PCI/CQI reports, the base station scheduler decides whether to schedule one or two data streams to the UE. It also decides what packet sizes (transport block sizes) and modulation schemes to use for each stream.

### 2.3.14.2 MIMO downlink control channel support

In order to support MIMO operation, changes to the HSDPA downlink control channel have become necessary, i.e. the HS-SCCH.

There is a new **HS-SCCH Type 3** for MIMO operation defined. The table below gives a comparison of the HS-SCCH Type 1 and Type 3 formats.

HS-SCCH Type 1	HS-SCCH Type 3	MIMO
(normal operation)	One transport block	Two transports blocks
Channelization code set information (7 bits)	Channelization code set information (7 bits)	Channelization code set information (7 bits)
Modulation scheme information (1 bit)	Modulation scheme and number of transport blocks information (3 bits)	Modulation scheme and number of transport blocks information (3 bits)
Transport block size information (6 bits)	Precoding weight information (2 bits)	Precoding weight information for primary transport block (2 bits)
HARQ process information (3 bits)	Transport block size information (6 bits)	Transport block size information for primary transport block (6 bits)
Redundancy and constellation version (3 bits)	HARQ process information (4 bits)	Transport block size information for secondary transport block (6 bits)
New data indicator (1 bit)	Redundancy and constellation version (2 bits)	HARQ process information (4 bits)
UE identity (16 bits)	UE identity (16 bits)	Redundancy and constellation version for primary transport block (2 bits)
		Redundancy and constellation version for secondary transport block (2 bits)
		UE identity (16 bits)

The "Precoding weight info for the primary transport block" contains the information on weight factor  $w_2$  as described above. Weight factors  $w_1$ ,  $w_3$ , and  $w_4$  are derived accordingly. The number of transport blocks transmitted and the modulation scheme information are jointly coded as shown in [Table 2-13](#).

**Table 2-13: Interpretation of "Modulation scheme and number of transport blocks info" sent on HS-SCCH**

Modulation scheme + number of transport blocks info (3 bits)	Modulation for primary transport block	Modulation for secondary transport block	Number of transport blocks
111	16QAM	16QAM	2
110	16QAM	QPSK	2
101	64QAM	n.a.	1
	64QAM	QPSK	2
100	16QAM	n.a.	1
011	QPSK	QPSK	2
010	64QAM	64QAM	2



Modulation scheme + number of transport blocks info (3 bits)	Modulation for primary transport block	Modulation for secondary transport block	Number of transport blocks
001	64QAM	16QAM	2
000	QPSK	n.a.	1

### 2.3.14.3 Redundancy version

Redundancy versions for the primary transport block and for the secondary transport block are signaled. Four redundancy version values are possible (unlike HSDPA in 3GPP release 5 where eight values for the redundancy version could be signaled).

### 2.3.14.4 HARQ processes

Also the signaling of the HARQ processes differs from HSDPA in 3GPP release 5. In 3GPP release 5, up to eight HARQ processes can be signaled. Configure a minimum of six HARQ processes to achieve continuous data transmission. Similarly, in MIMO with dual stream transmission, a minimum of 12 HARQ processes would be needed to achieve continuous data transmission.

Each HARQ process has independent acknowledgements and retransmissions. In theory, HARQ processes on both streams can run independently from one another. Independent HARQ processes, however, increases the signaling overhead to 8 bits.

To save signaling overhead, a restriction is introduced: HARQ processes are only signaled for the primary transport block within 4 bits, the HARQ process for the secondary transport block is derived from that according to a fixed rule. According to 3GPP TS 25.212. Thus, there is a one-to-one mapping between the HARQ process used for the primary transport block and the HARQ process used for the secondary transport block. The relation is shown in the table below for the example of 12 HARQ processes configured.

**Table 2-14: Combinations of HARQ process numbers for dual stream transmission (12 HARQ processes configured)**

HARQ process number on primary stream	0	1	2	3	4	5	6	7	8	9	10	11
HARQ process number on secondary stream	6	7	8	9	10	11	0	1	2	3	4	5



Only an even number of HARQ processes is allowed to be configured with MIMO operation.

### 2.3.14.5 MIMO uplink control channel support

Also the uplink control channel for HSDPA operation is affected by MIMO, i.e. the HS-DPCCH (high-speed dedicated physical control channel). In addition to CQI reporting as already defined from 3GPP release 5 onwards, PCI reporting for precoding feedback is introduced. Channel coding is done separately for the composite precoding control indication (PCI) / channel quality indication (CQI) and for HARQ-ACK (acknowledgment).

edgement or negative acknowledgement information). The figure below shows the principle.

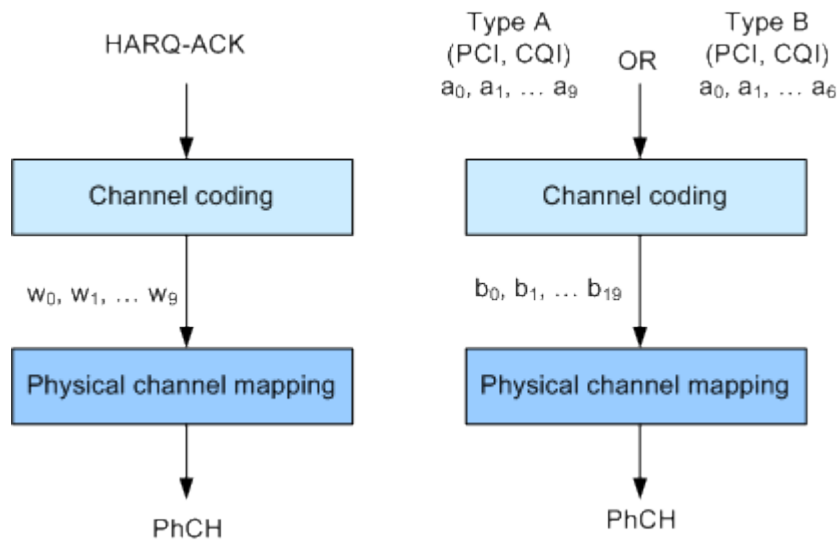

Figure 2-8: Channel coding for HS-DPCCH (MIMO mode)

The 10 bits of the HARQ-ACK messages are interpreted according to 3GPP TS 25.212 (see table below). ACK/NACK information is provided for the primary and for the secondary transport block.

Table 2-15: Interpretation of HARQ-ACK in MIMO operation (non-DC-HSDPA case)

HARQ-ACK message to be transmitted		w <sub>0</sub>	w <sub>1</sub>	w <sub>2</sub>	w <sub>3</sub>	w <sub>4</sub>	w <sub>5</sub>	w <sub>6</sub>	w <sub>7</sub>	w <sub>8</sub>	w <sub>9</sub>
HARQ-ACK in response to a single scheduled transport block											
ACK		1	1	1	1	1	1	1	1	1	1
NACK		0	0	0	0	0	0	0	0	0	0
HARQ-ACK in response to two scheduled transport blocks											
Response to primary transport block	Response to secondary transport block										
ACK	ACK	1	0	1	0	1	1	1	1	0	1
ACK	NACK	1	1	0	1	0	1	0	1	1	1
NACK	ACK	0	1	1	1	1	0	1	0	1	1
NACK	NACK	1	0	0	1	0	0	1	0	0	0
PRE/POST indication											
PRE		0	0	1	0	0	1	0	0	1	0
POST		0	1	0	0	1	0	0	1	0	0

### 2.3.14.6 CQI reports: type a and type b

In MIMO case, two types of CQI reports are supported:

- **Type A CQI reports** can indicate the supported transport formats for the number of transport blocks that the UE prefers. Single and dual stream transmissions are supported.
- **Type B CQI reports** are used for single stream transmission according to what has been defined from 3GPP release 5 onwards.

For type A CQI reports, the UE selects the CQI1 and CQI2 values for each transport block in dual stream transmission, or the CQIS value in single stream transmission. Then it creates the CQI value to report on HS-DPCCH as follows:

$$CQI = \begin{cases} 15 * CQI_1 + CQI_2 + 31 & \text{when 2 transport blocks are preferred by the UE} \\ CQI_s & \text{when 1 transport block is preferred by the UE} \end{cases}$$

For dual stream transmission, new CQI tables are specified in 3GPP TS25.214 for correct interpretation of transport formats based on CQI1 and CQI2.

### 2.3.14.7 PCI reports

The PCI value to report in the uplink is created in the UE according to the preferred precoding weight  $w_2$  according to the table below.

*Table 2-16: Mapping of preferred precoding weight to PCI values*

$w_2^{pref}$	$\frac{1+j}{2}$	$\frac{1-j}{2}$	$\frac{-1+j}{2}$	$\frac{-1-j}{2}$
PCI value	0	1	2	3

The PCI value is transmitted together with the CQI value as a composite PCI/CQI value. The figure below shows how the composite PCI/CQI report is created.

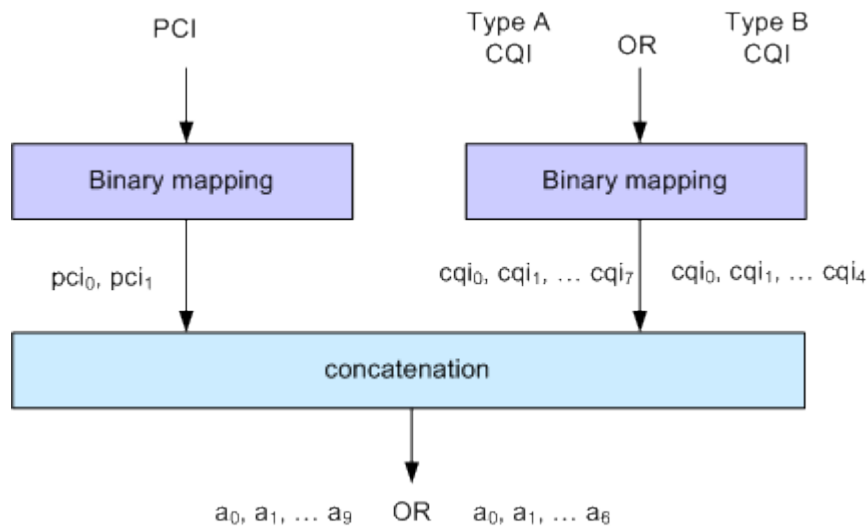

Figure 2-9: Composite PCI/CQI information (MIMO mode)

#### 2.3.14.8 MIMO fixed reference channels: H-Set 9 and H-Set 11

In order to support MIMO testing, two fixed reference channels have been introduced. H-Set 9 and H-Set 11 are specified as reference test channel for HSPA+ test cases.

The H-Set 9 parameterization and coding chain is based on 15 codes with two different modulations, 16QAM and QPSK, for the primary and secondary transport blocks respectively. Six HARQ processes are used, and HS-DSCH is continuously transmitted.

The H-Set 11 parameterization and coding chain is also based on 15 codes and uses two different modulations, six HARQ processes and HS-DSCH is continuously transmitted. The modulation schemes specified for the H-Set 11 are however **64QAM** and **16QAM** for the primary and secondary transport blocks respectively.

#### 2.3.15 Dual cell HSDPA (DC-HSDPA)

Within 3GPP Release 7 the peak user throughput was enhanced (MIMO, higher order modulation).

In DC-HSDPA operation, the UE is configured with secondary serving HS-DSCH cell. With one HS-SCCH in each of the two cells scheduling flexibility to have different transport formats depending on CQI feedback on each carrier is maintained.



Figure 2-10: Dual-cell HSDPA operation

The following restrictions apply in case of DC-HSDPA operation:

- The dual cell transmission only applies to HSDPA physical channels
- The two cells belong to the same Node-B
- In Release 8, it is required that the two cells are on adjacent carriers; from Release 9 onwards the paired cells can operate on two different frequency bands.
- The two cells use MIMO to serve UEs configured for dual cell operation

#### 2.3.15.1 DC-HSDPA data acknowledgement (non-MIMO mode)

When the UE is configured to work in DC-HSDPA non-MIMO mode, the coding of the HS-DPCCH is performed according to the general coding flow. The HARQ-ACK and the CQI are coded in parallel. The figure below shows the principle.

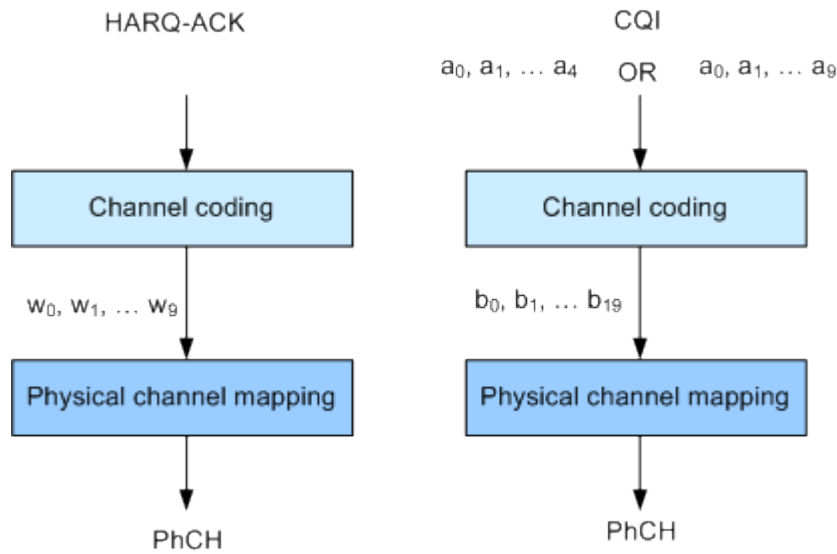

Figure 2-11: Channel coding for HS-DPCCH (non-MIMO mode)

The 10 bits of the HARQ-ACK messages are interpreted according to 3GPP TS 25.212 (see the table below). ACK/NACK information is provided for the transport block of the serving and secondary serving HS-DSCH cells.

Table 2-17: Interpretation of HARQ-ACK in DC-HSDPA non-MIMO operation

HARQ-ACK message to be transmitted	W <sub>0</sub>	W <sub>1</sub>	W <sub>2</sub>	W <sub>3</sub>	W <sub>4</sub>	W <sub>5</sub>	W <sub>6</sub>	W <sub>7</sub>	W <sub>8</sub>	W <sub>9</sub>
HARQ-ACK in response to a single scheduled transport block, detected on the serving HS-DSCH cell										
ACK	1	1	1	1	1	1	1	1	1	1
NACK	0	0	0	0	0	0	0	0	0	0
HARQ-ACK in response to a single scheduled transport block, detected on the secondary serving HS-DSCH cell										
ACK	1	1	1	1	1	0	0	0	0	0
NACK	0	0	0	0	0	1	1	1	1	1
HARQ-ACK in response to a single scheduled transport block, detected on each of the serving and secondary serving HS-DSCH cells										
Response to transport block from serving HS-DSCH cell	Response to transport block from secondary serving HS-DSCH cell									
ACK	ACK	1	0	1	0	1	0	1	0	1
ACK	NACK	1	1	0	0	1	1	0	0	1
NACK	ACK	0	0	1	1	0	0	1	1	0
NACK	NACK	0	1	0	1	0	1	0	1	0
PRE/POST indication										

PRE		0	0	1	0	0	1	0	0	1	0
POST		0	1	0	0	1	0	0	1	0	0

### CQI reports: CQI1 and CQI2

Two individual CQI reports CQI1 and CQI2 are concatenated to form the composite channel quality information. CQI1 corresponds to the serving HS-DSCH cell and CQI2 to the secondary serving cell respectively. The figure below show how the CQI report is constructed.

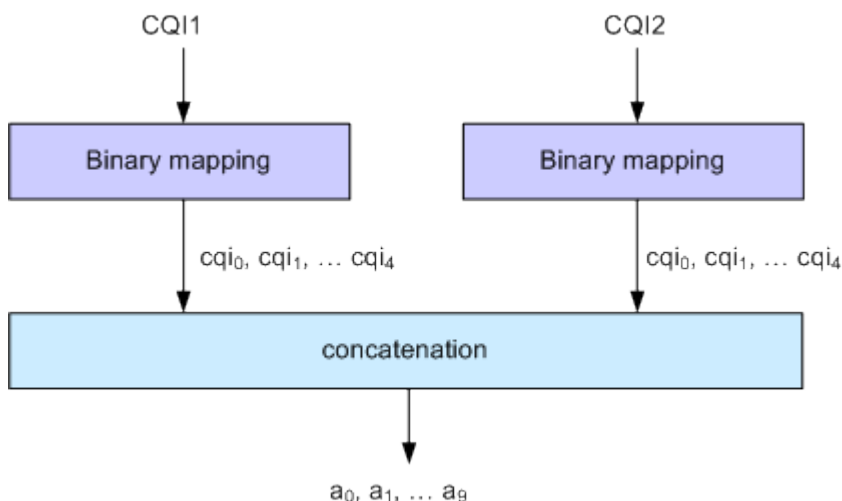

Figure 2-12: Composite CQI information (DC-HSDPA operation, non-MIMO mode)

### 2.3.15.2 DC-HSDPA + MIMO

Channel coding is done separately for the composite PCI/CQI and for HARQ-ACK information.

The principle is shown on figure [Figure 2-8](#).

The composite PCI/CQI report is created as illustrated on figure [Figure 2-9](#).

The HARQ-ACK message is coded to 10 bits according to 3GPP TS 25.212. The standard defines the HARQ-ACK coding for the feedback of the serving and secondary serving HS-DSCH cells for normal and dual stream transmission.

### 2.3.15.3 Dual cell HSDPA (DC-HSDPA) fixed reference channel: H-Set 12

In order to support DC-HSDPA testing, a fixed reference channel has been introduced. H-Set 12 is specified as reference test channel for HSDPA test cases.

The H-Set 12 parameterization and coding chain is based on 1 code with QPSK modulation. Six hybrid ARQ processes are used, and HS-DSCH is continuously transmitted.

### 2.3.16 HS-DPCCH extension for 4C-HSDPA and 8C-HSDPA

The 3GPP Release 11 extends the dual cell HSDPA (DC-HSDPA) transmission up to 8 cells HSDPA (8C-HSDPA). This extension enables the simultaneous scheduling of HSDPA transmission over four or eight cells, one serving and up to three or up to seven secondary serving cells. The transmissions on the serving cells are independent and are dynamically activated and deactivated.

For each of the cells, MIMO can be enabled. The channel coding of the feedback data transmitted via the HS-DPCCH is based on the same principle as in MIMO single cell transmission.

For detailed description on the channel coding, refer to the 3GPP specification TS 25.212.

The related instrument settings are described in [Chapter 3.30, "HS-DPCCH settings - UE"](#), on page 173.

### 2.3.17 Dual cell HSUPA (Dual cell E-DCH)

The Dual-Cell HSUPA employs carrier aggregation in the uplink. The DC-HSUPA operation is available only in combination with the DC-HSDPA. This operation uses two independent carriers, each assigned to one of the DC-HSDPA "cells".

### 2.3.18 UE capabilities

MIMO, 64QAM and DC-HSDPA operation in downlink as well as 16QAM in uplink are UE capability, i.e. not all UEs have to support them.

Several UE categories have been introduced to provide:

- DL MIMO support and support of 64QAM in addition to 16QAM and QPSK in downlink
- 16QAM support in uplink
- Support of dual cell operation and MIMO

The R&S SMBV100B supports all UE categories.

#### 2.3.18.1 MIMO and 64QAM UE capabilities

According to 3GPP TS25.306 V8.4.0, the following release 8 HS-DSCH categories with MIMO and 64QAM support are defined:

- Categories 13 and 14:
  - Support of 64QAM
  - No support of MIMO
  - Maximum data rate of category 14 is 21 Mbps
- Categories 15 and 16:
  - Support of MIMO with modulation schemes QPSK and 16QAM
  - No support of 64QAM
  - Maximum data rate of category 16 is 27.6 Mbps



- Categories 17 and 18:  
Support of MIMO with modulation schemes QPSK and 16QAM  
Support of 64QAM and MIMO, but not simultaneously  
Maximum data rate of category 18 is 27.6 Mbps when MIMO is used and 21 Mbps when 64QAM is used
- Categories 19 and 20:  
Simultaneous support of MIMO and all modulation schemes (QPSK, 16QAM and 64QAM)  
Maximum data rate of category 20 is 42.1 Mbps

#### 2.3.18.2 UL 16QAM UE capabilities

According to 3GPP TS25.306 V9.5.0, the following release 8 E-DCH categories with 16QAM uplink support are defined:

- Category 7 and 9:  
Support of 16QAM in addition to BPSK

#### 2.3.18.3 MIMO and DC-HSDPA operation UE capabilities

According to 3GPP TS25.306 V9.0.0, the following release 9 HS-DSCH categories with MIMO and dual cell operation support are defined:

- Categories 21, 22, 23 and 24:  
Support of QPSK, 16QAM and for categories 23 and 24 also 64QAM  
Support of dual cell operation, but without MIMO
- Categories 25, 26, 27 and 28:  
Support of QPSK, 16QAM and for categories 27 and 28 also 64QAM  
Simultaneous support of MIMO and dual cell operation

#### 2.3.18.4 Dual cell E-DCH operation UE capabilities

According to 3GPP TS25.306 V9.5.0, the following release 9 E-DCH categories with Dual-Cell E-DCH support are defined:

- Category 8:  
Supports only QPSK in Dual-Cell E-DCH operation
- Category 9:  
Supports QPSK and 16QAM in Dual-Cell E-DCH operation

### 2.3.19 Uplink discontinuous transmission (UL DTX)

Uplink discontinuous transmission (UL DTX) is one of the features of the continuous packet connectivity (CPC) provided to reduce the uplink control channel overhead. UL DTX allows the UE to stop transmission of uplink DPCCH in case there is no transmission activity on E-DCH or HS-DPCCH. This is sometimes also called uplink DPCCH gating.

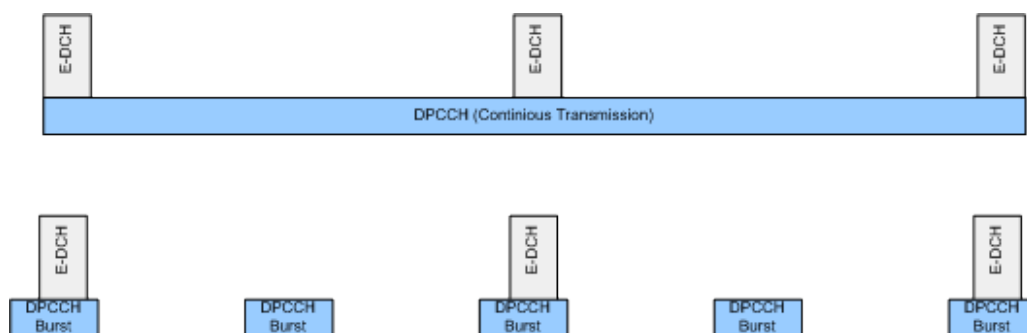

Figure 2-13: Principle of UL-DTX

Uplink DPCCH is not transmitted continuously any more, but it is transmitted from time to time according to a known activity pattern (UE-DTX cycle). This regular activity is needed in order to maintain synchronization and power control loop. Gating is only active if there is no uplink data transmission on E-DCH or HS-DPCCH transmission ongoing. In case E-DCH or HS-DPCCH is used, the uplink DPCCH is transmitted in parallel.

The 3GPP specifications define two patterns that can be applied to adapt the DTX cycle to the traffic conditions, the UE-DTX cycle 1 and the UE-DTX cycle 2 (see also [Chapter 4.3, "Configuring UL-DTX transmission and visualizing the scheduling"](#), on page 254). The UE-DTX cycle 1 is applied depending on the duration of E-DCH inactivity. The UE-DTX cycle 2 has less frequent DPCCH transmission instants and is applied whenever there is no uplink data transmission. The switching from UE-DTX cycle 1 to UE-DTX cycle 2 is determined by a configurable period of inactivity.

The transmission of control signaling on the HS-DPCCH is not affected by the UL-DTX pattern. With enabled UL-DTX, the HARQ-ACK messages and the CQI reporting remain unchanged and the UE transmits acknowledgment according to the HARQ-ACK pattern, regardless of the UL-DTX cycle. Transmission of control signals does not cause switching from UE-DTX cycle 2 to UE-DTX cycle 1.

A preamble and postamble are added to the DPCCH burst for synchronization reasons. The length of the uplink DPCCH preamble and postamble depend whether the DPCCH burst transmission is caused by user-data transmission on the E-DCH or control signaling on the HS-DPCCH.

- For the E-DCH transmission  
During the UE-DTX cycle 1, the DPCCH transmission starts two slots before the start of E-DPDCH and terminates one slot after it. For the UE-DTX cycle 2, an extended preamble of up to 15 slots is applied.
- For the HS-DPCCH transmission  
The preamble length depends whether an HARQ-ACK or CQI report is transmitted. Two slots are applied for the HARQ-ACK case (unless an HARQ preamble PRE is transmitted) and three in case of CQI reporting. For the latter case, an extended preamble is applied too.  
The DPCCH transmission terminates at the end of the first full DPCCH slot after the end of the HARQ-ACK/CQI field.

An instrument equipped with the required options provided an UL-DTX functionality, that is fully compliant with 3GPP TS 25.214. All dependencies from E-DCH transmis-

sions, HARQ-ACK transmissions or CQI transmissions on the DPCCH are respected. The corresponding settings are described in [Chapter 3.25, "UL-DTX/user scheduling - UE"](#), on page 154.



Use the [Scheduling list](#) to display the UL-DTX burst pattern and transmissions of E-DCH and HS-DPCCH, as well as the impact on the UL-DPCCH transmissions or the configured uplink user scheduling.

Refer to [Chapter 4.3, "Configuring UL-DTX transmission and visualizing the scheduling"](#), on page 254 for an example on how to use the UL-DTX function.

## 3 3GPP FDD configuration and settings

Access:

- ▶ Select "Baseband > 3GPP FDD".



The 3GPP FDD dialog is comprehensive. To simplify the description and the orientation through this documentation, the headings of the following section follow a common naming convention:

*<DialogName/TabName>< - ><SourceDialog>*

This common structure is intended to identify your current location in the dialog.

The remote commands required to define these settings are described in [Chapter 5, "Remote-control commands"](#), on page 259.

• <a href="#">General settings for 3GPP FDD signals</a> .....	45
• <a href="#">Trigger settings</a> .....	47
• <a href="#">Marker settings</a> .....	52
• <a href="#">Clock settings</a> .....	54
• <a href="#">Global connectors settings</a> .....	55
• <a href="#">Base stations and user equipment settings</a> .....	56
• <a href="#">Test setups/models</a> .....	62
• <a href="#">Predefined settings - downlink</a> .....	65
• <a href="#">Additional user equipment - uplink</a> .....	67
• <a href="#">Base station settings</a> .....	68
• <a href="#">Compressed mode</a> .....	82
• <a href="#">HSDPA settings - BS</a> .....	88
• <a href="#">HSDPA H-Set mode settings - BS</a> .....	92
• <a href="#">Enhanced settings for P-CPICH - BS1</a> .....	110
• <a href="#">Enhanced settings for P-CCPCH - BS1</a> .....	111
• <a href="#">Enhanced settings for DPCHs - BS1</a> .....	113
• <a href="#">S-CCPCH settings - BS channel table</a> .....	128
• <a href="#">Config AICH/AP-AICH - BS channel table</a> .....	130
• <a href="#">DPCCH settings - BS channel table</a> .....	131
• <a href="#">Config E-AGCH - BS channel table</a> .....	138
• <a href="#">Config E-RGCH/E-HICH - BS channel table</a> .....	140
• <a href="#">Config F-DPCH - BS channel table</a> .....	142
• <a href="#">Multi channel assistant - BS</a> .....	146
• <a href="#">User equipment configuration (UE)</a> .....	150
• <a href="#">UL-DTX/user scheduling - UE</a> .....	154
• <a href="#">Dynamic power control - UE</a> .....	157
• <a href="#">Scheduling list</a> .....	161
• <a href="#">DPCCH settings - UE</a> .....	162
• <a href="#">DPDCH settings - UE</a> .....	168
• <a href="#">HS-DPCCH settings - UE</a> .....	173
• <a href="#">E-DPCCH settings - UE</a> .....	194
• <a href="#">HSUPA FRC settings - UE</a> .....	196
• <a href="#">E-DPDCH settings - UE</a> .....	206

- [E-DCH scheduling - UE](#)..... 209
- [Global enhanced channel settings - UE1](#).....213
- [PRACH settings - UE](#).....222
- [PCPCH settings - UE](#).....233
- [Filtering, clipping, ARB settings](#)..... 245

### 3.1 General settings for 3GPP FDD signals

Access:

- ▶ Select "Baseband > 3GPP FDD".

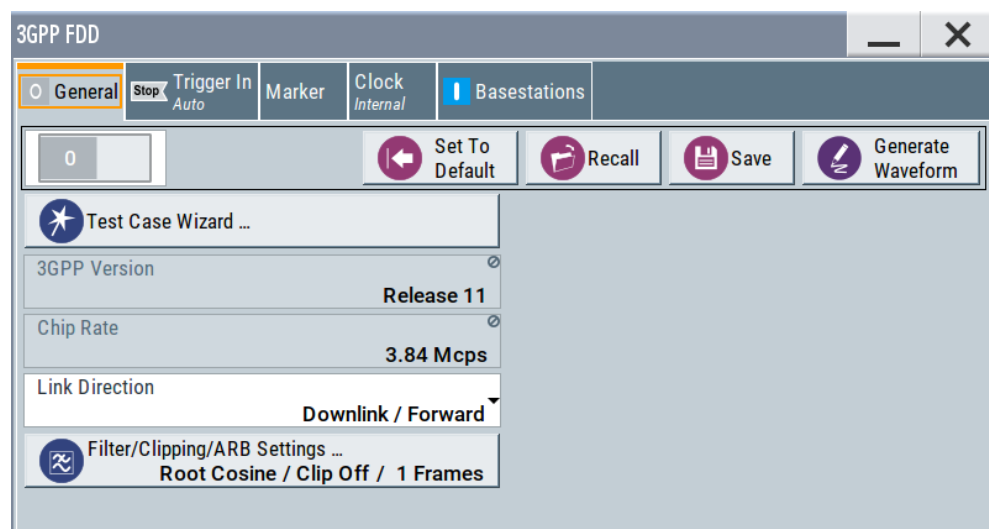

This tab comprises the standard general settings, valid for the signal in both transmission directions.

<a href="#">State</a> .....	45
<a href="#">Set to default</a> .....	46
<a href="#">Save/Recall</a> .....	46
<a href="#">Generate Waveform</a> .....	46
<a href="#">3GPP Version</a> .....	46
<a href="#">Chip Rate</a> .....	47
<a href="#">Link Direction</a> .....	47
<a href="#">Filtering/Clipping/ARB Settings</a> .....	47

#### State

Activates the standard and deactivates all the other digital standards and digital modulation modes in the same path.

The instrument generates the 3GPP FDD signal as a combination of realtime mode (enhanced channels) and arbitrary waveform mode (all the other channels). The following is a more detailed list of the channels generated in **real time**:

- *Downlink channels*: P-CCPCH and up to three DPCHs of base station 1 and H-Sets 1 to 5.
- *Uplink channels*: DPCCH and one DPDCH of user equipment 1.  
Depending on the actual configurations, other channels of user equipment 1 can also be generated in real time.

Generated in **arbitrary waveform mode** and added to the realtime signal are: PRACH and PCPCH channels and the channels of the other user equipment.

Remote command:

`[ :SOURce<hw> ] :BB:W3GPp:STATe` on page 262

### Set to default

Calls the default settings. Test Model 1 (64 channels) is preset.

The parameter "State" is not affected.

Remote command:

`[ :SOURce<hw> ] :BB:W3GPp:PRESet` on page 260

### Save/Recall

Accesses the "Save/Recall" dialog, i.e. the standard instrument function for storing and recalling the complete dialog-related settings in a file. The provided navigation possibilities in the dialog are self-explanatory.

The filename and the directory it is stored in are user-definable; the file extension is however predefined.

Remote command:

`[ :SOURce<hw> ] :BB:W3GPp:SETTing:CATalog?` on page 260

`[ :SOURce<hw> ] :BB:W3GPp:SETTing:LOAD` on page 261

`[ :SOURce<hw> ] :BB:W3GPp:SETTing:STORe` on page 262

`[ :SOURce<hw> ] :BB:W3GPp:SETTing:DELete` on page 261

### Generate Waveform

With enabled signal generation, triggers the instrument to save the current settings of an arbitrary waveform signal in a waveform file with predefined extension `*.wv`. You can define the filename and the directory, in that you want to save the file.

Using the ARB modulation source, you can play back waveform files and/or process the file to generate multi-carrier or multi-segment signals.

Remote command:

`[ :SOURce<hw> ] :BB:W3GPp:WAVeform:CREate` on page 263

### 3GPP Version

Displays the current implemented version of the 3GPP FDD standard.

The default settings and parameters provided are oriented towards the specifications of the version displayed.

Remote command:

`[ :SOURce ] :BB:W3GPp:GPP3:VERSion?` on page 263

**Chip Rate**

Displays the system chip rate, fixed at 3.84 Mcps.

To vary the output chip rate, use the parameters in the "Filter/Clipping/ARB Settings" dialog

See [Chapter 3.38, "Filtering, clipping, ARB settings"](#), on page 245.

Remote command:

[ :SOURce<hw> ] :BB:W3GPP:CRATe? on page 267

**Link Direction**

Selects the transmission direction. Further provided settings are in accordance with this selection.

"Downlink/ Forward Link" The transmission direction selected is base station to user equipment. The signal corresponds to that of a base station.

"Uplink/ Reverse Link" The transmission direction selected is user equipment to base station. The signal corresponds to that of user equipment.

Remote command:

[ :SOURce<hw> ] :BB:W3GPP:LINK on page 265

**Filtering/Clipping/ARB Settings**

Access a dialog for setting baseband filtering, clipping and the sequence length of the arbitrary waveform component. An indication of the key parameters values is provided.

See [Chapter 3.38, "Filtering, clipping, ARB settings"](#), on page 245 for detailed description.

Remote command:

n.a.

## 3.2 Trigger settings

Access:

- ▶ Select "Baseband" > "3GPP FDD" > "Trigger In".

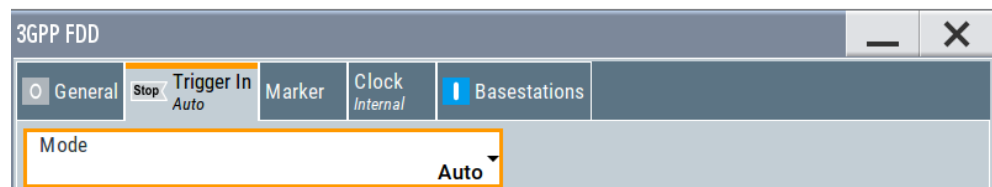

This tab provides settings to select and configure the trigger, like trigger source, trigger mode and trigger delays, and to arm or trigger an internal trigger manually. The header of the tab displays the status of the trigger signal and trigger mode. As in the tabs "Marker" and "Clock", this tab provides also access to the settings of the related connectors.

### Routing and activating a trigger signal

1. Define the effect of a trigger event and the trigger signal source.
  - a) Select "Trigger In" > "Mode".
  - b) Select "Trigger In" > "Source".
2. For external trigger signals, define the connector for signal input. See [Chapter 3.5, "Global connectors settings"](#), on page 55.  
You can map trigger signals to one or more User x connectors.  
Global connectors settings allow you to configure the signal mapping, the polarity, the trigger threshold and the input impedance of the input connectors.
3. Activate baseband signal generation. In the block diagram, set "Baseband" > "On".  
The R&S SMBV100B starts baseband signal generation after the configured trigger event.

### About baseband trigger signals

This section focuses on the available settings.

For information on how these settings affect the signal, refer to section "Basics on ..." in the R&S SMBV100B user manual.



The provided trigger signals are not dedicated to a particular connector. Trigger signals can be mapped to one or more User x connectors.

The provided trigger signals are not dedicated to a particular connector. Trigger signals can be mapped to one or two User x connectors.

Use the [Global connectors settings](#) to configure the signal mapping, the polarity, the trigger threshold and the input impedance of the input connectors.

To route and enable a trigger signal, proceed as follows:

- Define the signal source and the effect of a trigger event.  
Select "Trigger In" > "Mode" and "Trigger In" > "Source".
- Define the connector where the selected signal is provided.  
Use the "Global Connectors" settings.

Mode.....	49
Signal Duration Unit.....	49
Signal Duration.....	49
Running/Stopped.....	49
Time Based Trigger.....	50
Trigger Time.....	50
Arm.....	50
Execute Trigger.....	50
Source.....	50
Sync. Output to External Trigger/Sync. Output to Trigger.....	51
External Inhibit/Trigger Inhibit.....	52
Trigger Delay.....	52



**Mode**

Selects trigger mode, i.e. determines the effect of a trigger event on the signal generation.

- "Auto"  
The signal is generated continuously.
- "Retrigger"  
The signal is generated continuously. A trigger event (internal or external) causes a restart.
- "Armed Auto"  
The signal is generated only when a trigger event occurs. Then the signal is generated continuously.  
An "Arm" stops the signal generation. A subsequent trigger event (internal or external) causes a restart.
- "Armed Retrigger"  
The signal is generated only when a trigger event occurs. Then the signal is generated continuously. Every subsequent trigger event causes a restart.  
An "Arm" stops signal generation. A subsequent trigger event (internal or external) causes a restart.
- "Single"  
The signal is generated only when a trigger event occurs. Then the signal is generated once to the length specified at "Signal Duration".  
Every subsequent trigger event (internal or external) causes a restart.

Remote command:

[\[:SOURce<hw>\]:BB:W3GPp\[:TRIGger\]:SEQuence](#) on page 271

**Signal Duration Unit**

Defines the unit for describing the length of the signal sequence to be output in the "Single" trigger mode.

Remote command:

[\[:SOURce<hw>\]:BB:W3GPp:TRIGger:SLUNit](#) on page 275

**Signal Duration**

Requires trigger "Mode" > "Single".

Enters the length of the trigger signal sequence.

Use this parameter, for example, for the following applications:

- To output the trigger signal partly.
- To output a predefined sequence of the trigger signal.

Remote command:

[\[:SOURce<hw>\]:BB:W3GPp:TRIGger:SLENgth](#) on page 274

**Running/Stopped**

With enabled modulation, displays the status of signal generation for all trigger modes.

- "Running"  
The signal is generated; a trigger was (internally or externally) initiated in triggered mode.
- "Stopped"  
The signal is not generated and the instrument waits for a trigger event.

Remote command:

[\[:SOURce<hw>\]:BB:W3GPp:TRIGger:RMODe?](#) on page 273

### Time Based Trigger

Requires trigger "Mode" > "Armed Auto"/"Single".

Activates time-based triggering with a fixed time reference.

The R&S SMBV100B triggers signal generation when its operating system time ("Current Time") matches a specified time trigger ("Trigger Time"). As trigger source, you can use an internal trigger or an external global trigger.

How to: Chapter "Time-based triggering" in the R&S SMBV100B user manual.

Remote command:

[\[:SOURce<hw>\]:BB:W3GPp:TRIGger:TIME\[:STATe\]](#) on page 274

### Trigger Time

Requires trigger "Mode" > "Armed Auto"/"Single".

Sets date and time for a time-based trigger signal.

Set a trigger time that is later than the "Current Time". The current time is the operating system time of the R&S SMBV100B. If you set an earlier trigger time than the current time, time-based triggering is not possible.

How to: Chapter "Time-based triggering" in the R&S SMBV100B user manual.

"Date" Sets the date of the time-based trigger in format YYYY-MM-DD.

Remote command:

[\[:SOURce<hw>\]:BB:W3GPp:TRIGger:TIME:DATE](#) on page 273

"Time" Sets the time of the time-based trigger in format hh:mm:ss.

Remote command:

[\[:SOURce<hw>\]:BB:W3GPp:TRIGger:TIME:TIME](#) on page 274

### Arm

Stops the signal generation until subsequent trigger event occurs.

Remote command:

[\[:SOURce<hw>\]:BB:W3GPp:TRIGger:ARM:EXECute](#) on page 272

### Execute Trigger

For internal trigger source, executes trigger manually.

Remote command:

[\[:SOURce<hw>\]:BB:W3GPp:TRIGger:EXECute](#) on page 272

### Source

The following sources of the trigger signal are available:

- "Internal"
  - The trigger event is executed manually by the "Execute Trigger".
- "External Global Trigger"
  - The trigger event is the active edge of an external trigger signal provided and configured at the User x connectors.
- "Baseband Sync In"

In primary-secondary instrument mode, secondary instruments are triggered by the active edge of the synchronization signal.

How to: "[Routing and activating a trigger signal](#)" on page 48

Remote command:

`[ :SOURce<hw> ] :BB:W3GPp:TRIGger:SOURce` on page 272

### Sync. Output to External Trigger/Sync. Output to Trigger

Enables signal output synchronous to the trigger event.

- "On"

Corresponds to the default state of this parameter.

The signal calculation starts simultaneously with the trigger event. Because of the processing time of the instrument, the first samples are cut off and no signal is output. After elapsing of the internal processing time, the output signal is synchronous to the trigger event.

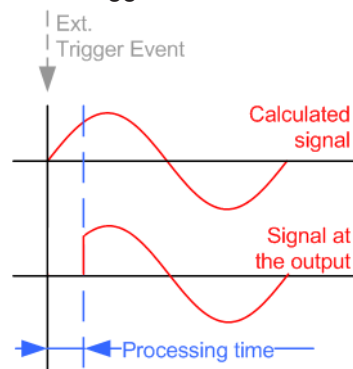

- "Off"

The signal output begins after elapsing of the processing time. Signal output starts with sample 0. The complete signal is output.

This mode is recommended for triggering of short signal sequences. Short sequences are sequences with signal duration comparable with the processing time of the instrument.

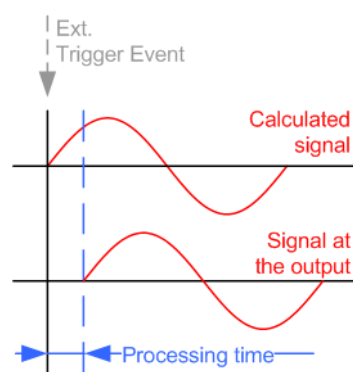

In primary-secondary instrument mode, this setting ensures that once achieved, synchronization is not lost if the baseband signal sampling rate changes.

Remote command:

`[ :SOURce<hw> ] :BB:W3GPp:TRIGger:EXTeRnal:SYNChronize:OUTPut` on page 273

**External Inhibit/Trigger Inhibit**

For external trigger signal or trigger signal from the other path, sets the duration with that any following trigger event is suppressed. In "Retrigger" mode, for example, a new trigger event does not cause a restart of the signal generation until the specified inhibit duration does not expire.

For more information, see chapter "Basics" in the R&S SMBV100B User Manual.

Remote command:

`[ :SOURce<hw> ] :BB:W3GPP:TRIGger [ :EXTernal ] :INHibit` on page 275

**Trigger Delay**

Delays the trigger event of the signal from:

- The external trigger source

Use this setting to:

- Synchronize the instrument with the device under test (DUT) or other external devices
- Compensate delays and align the signal generation start in multi-instrument setup

For more information, see chapter "Basics on ..." in the R&S SMBV100B user manual.

Remote command:

`[ :SOURce<hw> ] :BB:W3GPP:TRIGger [ :EXTernal ] :DELay` on page 275

## 3.3 Marker settings

Access:

- ▶ Select "Baseband" > "3GPP FDD" > "Marker".

This tab provides settings to select and configure the marker output signal including marker mode and marker delay.

**Routing and activating a marker signal**

1. To define the signal shape of an individual marker signal "x", select "Marker" > "Marker x" > "Mode".
2. Optionally, define the connector for signal output. See [Chapter 3.5, "Global connectors settings"](#), on page 55.  
You can map marker signals to one or more User x connectors.
3. Activate baseband signal generation. In the block diagram, set "Baseband" > "On".  
The R&S SMBV100B adds the marker signal to the baseband signal. Also, R&S SMBV100B outputs this signal at the configured User x connector.

**About marker output signals**

This section focuses on the available settings.

For information on how these settings affect the signal, refer to section "Basics on ..." in the R&S SMBV100B user manual.

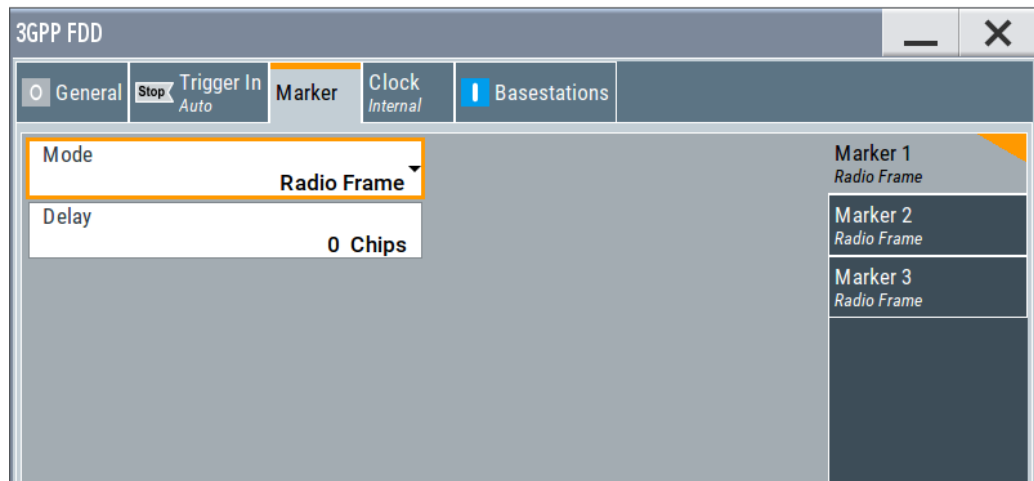

### Routing and enabling a marker

The provided marker signals are not dedicated to a particular connector. They can be mapped to one or more User x connectors.

To route and enable a marker signal, perform the following *general steps*:

- Define the shape of the generated marker, i.e. select the "Marker > Mode".
- Define the connector where the selected signal is provided.  
Use the [Global connectors settings](#).

### Marker Mode

Marker configuration for up to 3 markers. The settings are used to select the marker mode defining the shape and periodicity of the markers. The contents of the dialog change with the selected marker mode.

- |                                     |   |
|-------------------------------------|---|
| "Slot"                              | A marker signal is generated at the start of each slot (every 2560 chips or 0.667 ms).  |
| "Radio Frame"                       | A marker signal is generated at the start of each frame (every 38400 chips or 10 ms).   |
| "Chip Sequence Period (ARB)"        | A marker signal is generated at the start of every arbitrary waveform sequence (depending on the setting for the arbitrary waveform sequence length). If the signal does not contain an arbitrary waveform component, a radio frame trigger is generated. |
| "System Frame Number (SFN) Restart" | A marker signal is generated at the start of every SFN period (every 4096 frames).  |

"ON/OFF Ratio" A regular marker signal that is defined by an on/off ratio is generated. A period lasts one on and off cycle.

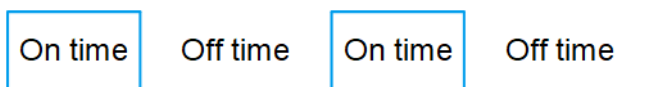

Remote command:

`[ :SOURCE<hw> ] :BB:W3GPP:TRIGGER:OUTPUT<ch>:ONTime`  
on page 276

`[ :SOURCE<hw> ] :BB:W3GPP:TRIGGER:OUTPUT<ch>:OFFTime`  
on page 276

"User" A marker signal is generated at the beginning of every user-defined "Period".

Remote command:

`[ :SOURCE<hw> ] :BB:W3GPP:TRIGGER:OUTPUT<ch>:PERIOD`  
on page 277

"Multi Gated" An internally used marker signal.

Marker 2 and Marker 3 are automatically set to this value in the following configuration:

- "Link Direction > Uplink"
- "User Equipment > UE1 > On"
- "User Equipment > UL-DTX/User Scheduling > State > On"

Remote command:

`[ :SOURCE<hw> ] :BB:W3GPP:TRIGGER:OUTPUT<ch>:MODE` on page 276

#### Marker x Delay

Delays the marker signal at the marker output relative to the signal generation start.

Variation of the parameter "Marker x" > "Delay" causes signal recalculation.

Remote command:

`[ :SOURCE<hw> ] :BB:W3GPP:TRIGGER:OUTPUT<ch>:DELAY` on page 277

## 3.4 Clock settings

Access:

- ▶ Select "Baseband" > "3GPP FDD" > "Clock".



This tab provides settings to select and configure the clock signal, like the clock source and clock mode.

**Defining the clock**

1. Select "Clock" > "Source" to define the source of clock signal.
2. For external clock signals, define the connector for signal input. See [Chapter 3.5, "Global connectors settings"](#), on page 55.  
You can map clock signals to one or more User x connectors.  
Global connectors settings allow you to configure the signal mapping, the polarity, the trigger threshold and the input impedance of the input connectors.
3. Activate baseband signal generation. In the block diagram, set "Baseband" > "On".  
The R&S SMBV100B starts baseband signal generation with a symbol rate that equals the clock rate.

**About clock signals**

This section focuses on the available settings.

For information on how these settings affect the signal, refer to section "Basics on ..." in the R&S SMBV100B user manual.

**Defining the clock**

The provided clock signals are not dedicated to a particular connector. They can be mapped to one or more User x connectors.

Use the [Global connectors settings](#) to configure the signal mapping, the polarity, the trigger threshold, and the input impedance of the input connectors.

To route and enable a trigger signal, perform the following *general steps*:

- Define the signal source, that is select the "Clock > Source".
- Define the connector where the selected signal is provided.  
Use the [Global connectors settings](#).

[Clock Source](#).....55

**Clock Source**

Selects the clock source.

- "Internal"  
The instrument uses its internal clock reference.

How to: ["Defining the clock"](#) on page 55

## 3.5 Global connectors settings

Accesses a dialog to configure global connectors.

The button is available in the following dialogs or tabs:

- "Trigger / Marker / Clock" dialog that is accessible via the "TMC" block in the block diagram.

- "Trigger In", "Marker" and "Clock" tabs that are accessible via the "Baseband" block in the block diagram.

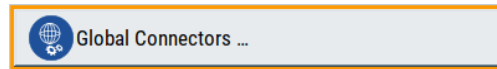

See also chapter "Global connectors settings" in the user manual.

### 3.6 Base stations and user equipment settings

Depending on the selected link direction, the last tab comprises either the "Basestations" or the "User Equipment" common settings.

- "Link Direction > Downlink"

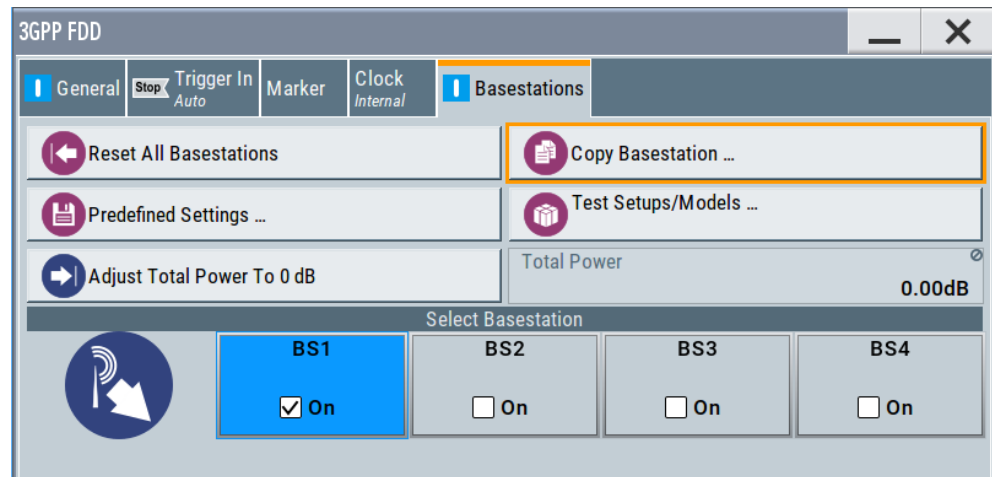

- "Link Direction > Uplink"

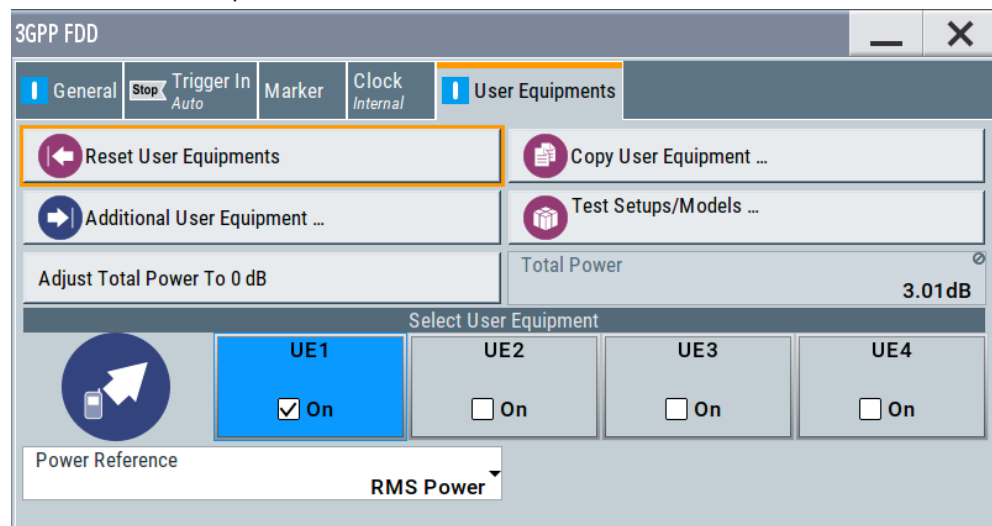

This section describes the configuration settings common for both tabs, like OCNS settings or power configuration.



### 3.6.1 Common configuration settings

The "Configure Basestations / User Equipments" tabs cover the general parameters for configuring the respective transmission direction.

#### Reset all Base Stations

Resets all base stations to the predefined settings. The preset value for each parameter is specified in the description of the remote-control commands.

**Table 3-1: Overview of the base station predefined settings**

Parameter	Value
State	Off
State (all channels)	Off
Scrambling Code	0
Slot Format DPCH	8
Symbol Rate DPCH	30 ksps
Channelization Code (all channels)	0
Data Source (all channels)	PN9
Timing Offset (all channels)	0
Multi-Code State (all channels)	Off

Remote command:

[\[:SOURCE<hw>\]:BB:W3GPP:BSTation:PRESet](#) on page 263

#### Reset User Equipment

Resets all user equipment to the predefined settings. The preset value for each parameter is specified in the description of the remote-control commands.

**Table 3-2: Overview of the user equipment predefined settings**

Parameter	Value
State	Off
Mode	DPCCH + DPDCH
Scrambling Code (hex)	0
DPCCH Settings	
Power	0 dB
DPDCH Settings	
DPDCH State	On
HS-DPCCH, E-DPCCH and E-DPDCH State	Off
Channel Power	0 dB
Overall Symbol Rate	60 ksps

Remote command:

[\[:SOURCE<hw>\]:BB:W3GPP:MSTation:PRESet](#) on page 353

### Copy Basestation/Copy User Equipment...

Copies the settings of a base station or user equipment to a second base or user equipment. A dialog opens for creating the destination station.

#### Downlink / Forward link direction

#### Uplink / Reverse link direction

#### "Copy from Source"

Selects the base station or user equipment whose settings are to be copied.

Remote command:

[\[:SOURCE<hw>\]:BB:W3GPP:COPY:SOURCE](#) on page 264

#### "To Destination"

Selects the base station or user equipment whose settings are to be overwritten.

Remote command:

[\[:SOURCE<hw>\]:BB:W3GPP:COPY:DESTINATION](#) on page 264

#### "Channelization Code Offset (Base Station only)"

Enters the offset to be applied when copying the base station to the channelization codes of the destination base station. The minimum value is 0 (channelization codes are identical), the maximum value is 511.

Remote command:

[\[:SOURCE<hw>\]:BB:W3GPP:COPY:COFFset](#) on page 263

#### "Accept"

Starts the copy process.

Remote command:

[\[:SOURCE<hw>\]:BB:W3GPP:COPY:EXECute](#) on page 264

**Test Setups/Models**

Accesses the test models defined in the 3GPP standard and further test setups, see [Chapter 3.7, "Test setups/models"](#), on page 62.

Provided are test models for downlink and uplink:

- ["Test Models Downlink"](#) on page 62
- ["Test Models Uplink"](#) on page 63

Remote command:

n.a.

**Predefined Settings**

Access a dialog for setting predefined configurations, see [Chapter 3.8, "Predefined settings - downlink"](#), on page 65.

Remote command:

n.a.

**Additional User Equipment**

Access a dialog for simulating up to 128 additional user equipment, see [Chapter 3.9, "Additional user equipment - uplink"](#), on page 67.

Remote command:

n.a.

**Select Basestation/User Equipment**

Selects the base station or user equipment by pressing the accompanying block.

A dialog for editing the selected basestation or user equipment opens (see [Chapter 3.10, "Base station settings"](#), on page 68 and [Chapter 3.24, "User equipment configuration \(UE\)"](#), on page 150).

To activate a base station or user equipment, enable its state.

Remote command:

(the base station or user equipment is selected by the keyword index  
BSTation<[1] | 2 | 3 | 4> or MSTation<i>)

[\[:SOURce<hw>\]:BB:W3GPp:BSTation<st>:STATe](#) on page 328

[\[:SOURce<hw>\]:BB:W3GPp:MSTation<st>:STATe](#) on page 354

**3.6.2 General power settings**

The power settings are enabled for "3GPP FDD > State = On".

**Adjust Total Power To 0 dB**

Sets the power of the enabled channels so that the total power of all the active channels is 0 dB. The behavior does not change the power ratio among the individual channels.

Remote command:

[\[:SOURce<hw>\]:BB:W3GPp:POWer:ADJust](#) on page 265

**Total Power**

Displays the total power of the active channels.

The total power is calculated from the power ratio of the powered up code channels with modulation on. If the value is not equal to 0 dB, the individual code channels are internally adapted so that the "Total Power" for achieving the set output level is 0 dB. The power ratios are maintained.

Remote command:

[ :SOURce<hw> ] :BB:W3Gpp:POWer [ :TOTal ] ? on page 265

### Power Reference

Determines the power reference for the leveling of the output signal in uplink direction.

Power references "First E-DCH", "First HARQ-ACK" and "First PCI/CQI" require R&S SMBVB-K83.

Parameter	Power leveling performed during	Power displayed in "Status bar > Level" is equal to	"Mode" of the first active UE
"RMS Power"	Complete signal	Output signal's mean power	<ul style="list-style-type: none"> <li>• PRACH Standard</li> <li>• PRACH Preamble only</li> <li>• DPCCH+DPDCH and UL-DTX Off</li> <li>• PCPCH Standard</li> <li>• PCPCH Preamble only</li> </ul>
"First DPCCH" "First E-DCH" "First HARQ-ACK" "First PCI/CQI"	First slot in which a DPCCH, an E-DCH, an HARQ-ACK or a PCI/CQI is transmitted in the first active UE.	Output signal's mean power during the first active DPCCH  <b>Note:</b> if there are other UEs or channels active during the reference slot, the total power is used as a reference, not only the DPCCH power.  This mode is required if the UL-DTX is enabled, due to the long signal parts of inactivity.	<ul style="list-style-type: none"> <li>• DPCCH+DPDCH and UL-DTX On</li> <li>• DPCCH+DPDCH and UL-DTX Off</li> </ul>
"PRACH Mes- sage Part"	PRACH message part of the first active UE	Output signal's mean power during the PRACH message part	PRACH Standard
"Last PRACH Preamble"	Last PRACH preamble of the first active UE	Output signal's mean power during the last PRACH preamble	<ul style="list-style-type: none"> <li>• PRACH Standard</li> <li>• PRACH Preamble only</li> </ul>

### Example:

- "RF Level" = -10 dBm (value displayed in the status bar of the instrument)
- DPCCH is activated.
- E-DPCCH and one E-DPDCH are activated in the first subframe of each frame.

The [Figure 3-1](#) displays the power versus time for "Power Reference = First DPCCH": the signal level in the first subframe is -10 dBm; the RMS power of the signal is -13.3 dBm.

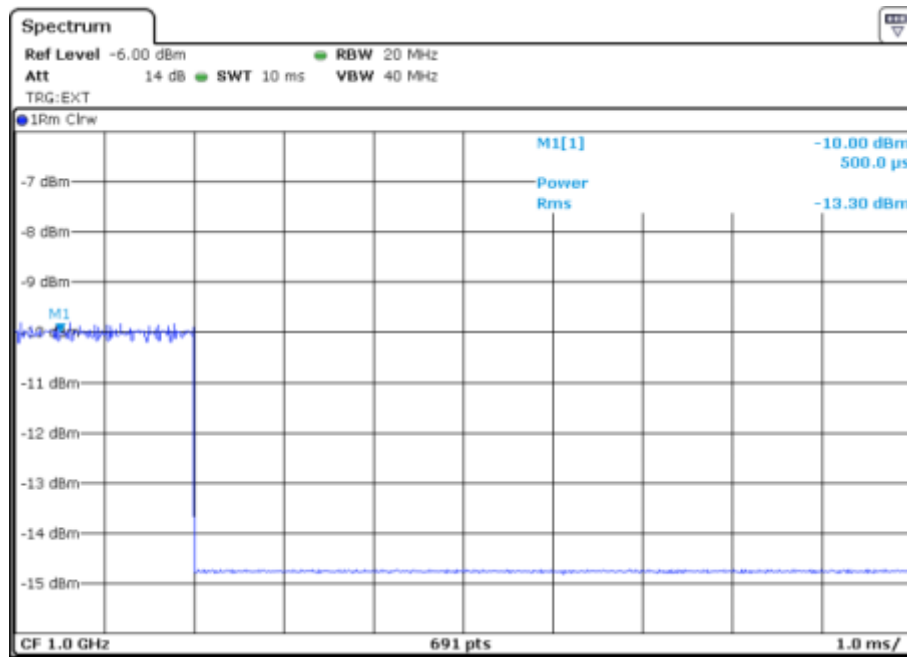

Figure 3-1: Example: Power Reference = First DPCCH

The Figure 3-2 displays the power versus time for "Power Reference = RMS": the RMS power of the signal is -10 dBm; the signal level in the first subframe is -6.7 dBm.

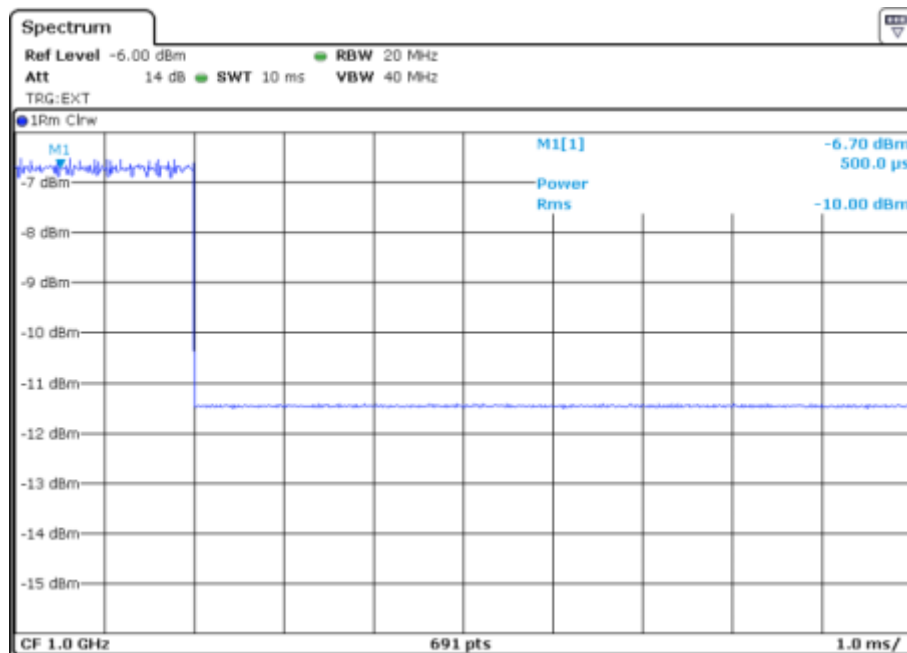

Figure 3-2: Example: Level Reference = RMS

Remote command:

[ :SOURce<hw> ] :BB:W3GPP:LREference on page 355

## 3.7 Test setups/models

Access:

- ▶ Select "3GPP FFD > Basestation/User Equipment > Test Setup/Models"

The dialog offers various test models, depending on the selected transmission direction. The presetting is defined in the 3GPP standard TS 25.141.

### Test Models Downlink

The dialog lists test models in accordance with the 3GPP standard TS 25.141.

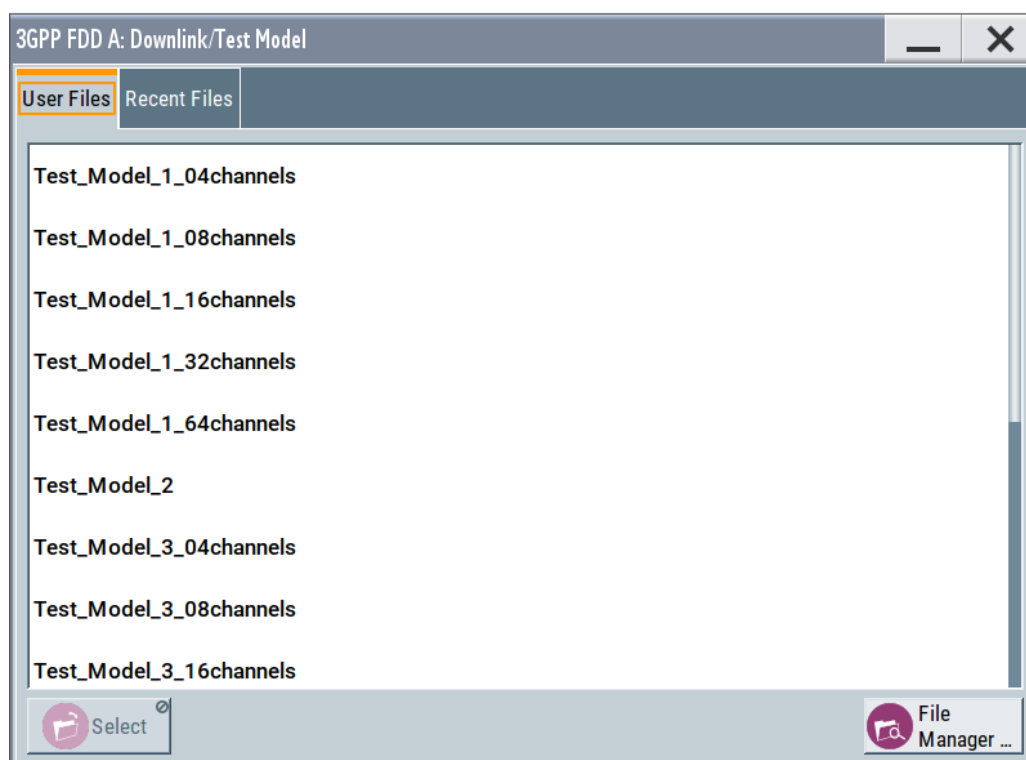

Selecting a test model for an active base station immediately generates the selected signal configuration.

The [Table 3-3](#) gives an overview of the available test models.

**Table 3-3: Test Models Downlink**

Test Model	Description
"Test Model 1 (4/8 channels)"	Test models for Home BS <ul style="list-style-type: none"> <li>• Spectrum emission mask</li> <li>• ACLR</li> <li>• Spurious emissions</li> <li>• Transmit intermodulation</li> <li>• Modulation accuracy</li> <li>• Peak code domain error</li> </ul>
"Test Model 1 (16/32/64 channels)"	<ul style="list-style-type: none"> <li>• Spectrum emission mask</li> <li>• ACLR</li> <li>• Spurious emissions</li> <li>• Transmit intermodulation</li> <li>• Modulation accuracy</li> <li>• Peak code domain error</li> </ul>
"Test Model 2"	Output power dynamics
"Test Model 3 (4/8 channels)"	Peak code domain error test models for Home BS
"Test Model 3 (16/32 channels)"	Peak code domain error
"Test Model 4"	Error Vector Magnitude, optional P-CPICH is not active
"Test Model 4 (CPICH)"	Error Vector Magnitude, optional P-CPICH is active.
"Test Model 5 (4 HS-PDSCH + 4 DPCH)"	Error Vector Magnitude test models for Home BS at base stations that support high-speed physical downlink shared channels with 16 QAM
"Test Model 5 (8 HS-PDSCH + 30 DPCH)" "Test Model 5 (4 HS-PDSCH + 14 DPCH)" "Test Model 5 (2 HS-PDSCH + 6 DPCH)"	Error Vector Magnitude at base stations that support high-speed physical downlink shared channels with 16 QAM
"Test Model 6_04_4channels"	Relative Code Domain Error test models for Home BS only applicable for 64QAM modulated codes.
"Test Model 6_30_8channels"	Relative Code Domain Error only applicable for 64QAM modulated codes.

Remote command:

[\[:SOURCE<hw>\]:BB:W3GPP:SETTING:TModel:BSTation:CATalog?](#)  
on page 281

[\[:SOURCE<hw>\]:BB:W3GPP:SETTING:TModel:BSTation](#) on page 281

### Test Models Uplink

The dialog lists test models with predefined test signals.

The 3GPP has not defined any test models for the Uplink transmission direction. This implementation however, provides a list of useful test signals and enables you to generate an uplink signal quickly.

This instrument generates the Uplink test models in the enhanced state of user equipment 1. An exception is the test models for the E-DPCCH and E-DPDCH, these channels are not calculated in real time. The sequence length is not changed.

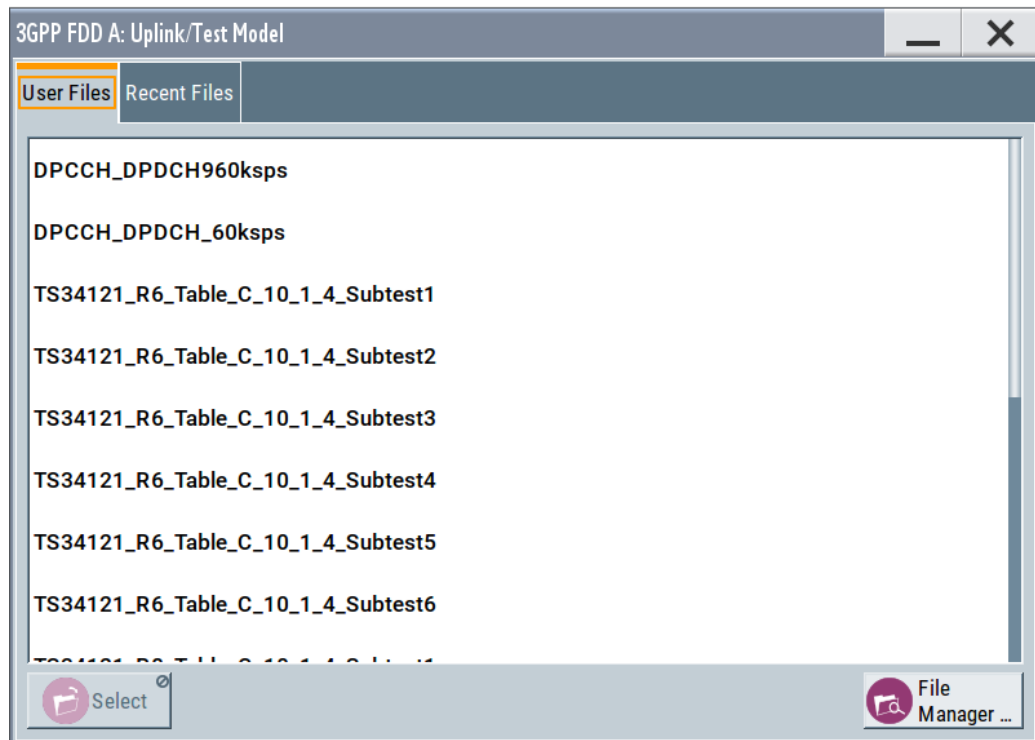

The following table lists some examples of configurations available for selection.

**Table 3-4: Test Models Uplink**

Test Model	Description
"DPCCH + DPDCH 60 ksps"	User equipment 1 is activated in DPCCH + DPDCH mode. 60 ksps is selected as the overall symbol rate. All the other settings correspond to the preset setting.
"DPCCH + DPDCH 960 ksps"	User equipment 1 is activated in DPCCH + DPDCH mode. 960 ksps is selected as the overall symbol rate. All the other settings correspond to the preset setting.
"TS34121_R6_Table_C_10_1_4_Subset1 .. 6"	Uplink test model according to 3GPP TS 34.121 Release 6, Table C.10.1.4.
"TS34121_R8_Table_C_10_1_4_Subset1 .. 4"	Uplink test models for transmitter characteristics tests with HS-DPCCH according to 3GPP TS 34.121 Release 8, Table C.10.1.4.
"TS34121_R8_Table_C_11_1_3_Subset1 .. 5"	Uplink test models for transmitter characteristics tests with HS-DPCCH and E-DCH according to 3GPP TS 34.121 Release 8, Table C.11.1.3.
"TS34121_R8_Table_C_11_1_4_Subset1"	Uplink test model for transmitter characteristics tests with HS-DPCCH and E-DCH with 16QAM according to 3GPP TS 34.121 Release 8, Table C.11.1.4.

Remote command:

`[ :SOURCE<hw> ] :BB:W3GPP:SETTING:TModel:MStation:CATalog?`

on page 282

`[ :SOURCE<hw> ] :BB:W3GPP:SETTING:TModel:MStation` on page 281



### 3.8 Predefined settings - downlink

With the "Predefined Settings" function, it is possible to create highly complex scenarios with just a few modifications. This function is of use if, say, just the envelope of the signal is of interest.

Access:

1. Select "3GPP FDD > Link Direction > Downlink".
2. Select "Basestation > Predefined Settings".

3GPP FDD A: Predefined Settings	
Use Channels needed for Sync of Mobile (UE): P-CPICH,P-SCH,S-SCH,PCCPCH	<input checked="" type="checkbox"/>
Use S-CCPCH	<input type="checkbox"/>
Symbol Rate S-CCPCH	30 ksps
Number Of DPCH	10
Symbol Rate DPCH	30 ksps
Crest Factor	Minimum
<input checked="" type="checkbox"/> Accept	

The channel table of base station 1 is filled (preset) with the set parameters. The sequence length of the generated signal is 1 frame.

#### Use Channels

Selects whether P-CPICH, P-SCH, S-SCH and PCCPCH are used in the scenario or not. These "special channels" are required by user equipment for synchronization.

Remote command:

[\[:SOURCE<hw>\]:BB:W3GPP:PPARAMETER:SCHANNELS](#) on page 280

#### Use S-CCPCH

Selects if S-CCPCH is used in the scenario or not.

Remote command:

[ :SOURce<hw> ] :BB:W3GPp:PPARameter:SCCPch:STATe on page 280

### Symbol Rate S-CCPCH

Sets the symbol rate of S-CCPCH.

Remote command:

[ :SOURce<hw> ] :BB:W3GPp:PPARameter:SCCPch:SRATe on page 280

### Number of DPCH

Sets the number of activated DPCHs.

The maximum number is the ratio of the chip rate and the symbol rate (maximum 512 at the lowest symbol rate of 7.5 ksps).

Remote command:

[ :SOURce<hw> ] :BB:W3GPp:PPARameter:DPCH:COUNT on page 279

### Symbol Rate DPCH

Sets the symbol rate of all DPCHs.

Remote command:

[ :SOURce<hw> ] :BB:W3GPp:PPARameter:DPCH:SRATe on page 279

### Crest Factor

Selects desired range for the crest factor of the test scenario. The crest factor of the signal is kept in the desired range by automatically setting appropriate channelization codes and timing offsets.

"Minimum"	The crest factor is minimized. The channelization codes are distributed uniformly over the code domain. The timing offsets are increased by 3 per channel.
"Average"	An average crest factor is set. The channelization codes are distributed uniformly over the code domain. The timing offsets are all set to 0.
"Worst"	The crest factor is set to an unfavorable value (i.e. maximum). The channelization codes are assigned in ascending order. The timing offsets are all set to 0.

Remote command:

[ :SOURce<hw> ] :BB:W3GPp:PPARameter:CRESt on page 278

### Accept

Presets the channel table of basestation 1 with the parameters defined in the Predefined Settings menu. Scrambling Code 0 is automatically selected (as defined in the 3GPP test models).

Remote command:

[ :SOURce<hw> ] :BB:W3GPp:PPARameter:EXECute on page 279

### 3.9 Additional user equipment - uplink

Access:

1. Select "3GPP FDD > Link Direction > Uplink".
2. In the "User Equipment" tab , select "Additional User Equipment".

3GPP FDD A: Add UE (Based On UE4)	
State	<input type="checkbox"/>
Number of additional UE	4
Scrambling Code Step	00 0001
Power Offset	0.00 dB
Time Delay Step	0 Chips

The dialog allows you to simulate up to 128 additional user equipment and thus to generate a signal that corresponds to the received signal for a base station with high capacity utilization.

The fourth user equipment (UE4) serves as a template for all other stations.

The following parameters are the only ones modified for the additional user equipment:

- Scrambling code (different for all stations)
- Power (different to UE4, but identical among themselves)

#### State

Enables/disables all additional user equipment.

Remote command:

`[ :SOURCE<hw> ] :BB:W3GPP:MSTation:ADDITIONAL:STATE` on page 352

**Number of Additional UE**

Sets the amount of additional user equipment. As many as 128 additional user equipment can be simulated.

Remote command:

`[ :SOURce<hw> ] :BB:W3GPP:MSTation:ADDITIONAL:COUNT` on page 351

**Scrambling Code Step**

Enters the step width for increasing the scrambling code of the additional user equipment. The start value is the scrambling code of UE4.

Remote command:

`[ :SOURce<hw> ] :BB:W3GPP:MSTation:ADDITIONAL:SCODE:STEP` on page 352

**Power Offset**

Sets the power offset of the active channels of the additional user equipment to the power outputs of the active channels of UE4.

The resultant power must fall within the range 0 dB to - 80 dB. If the value is above or below this range, it is limited automatically.

Remote command:

`[ :SOURce<hw> ] :BB:W3GPP:MSTation:ADDITIONAL:POWER:OFFSET`  
on page 351

**Time Delay Step**

Enters the step width for the time delay of the additional user equipment to one another. The start value returns the time delay of UE4. Entry is made in chips and can be a maximum of one frame.

The time delay allows user equipment to be simulated even if the arrival of their signals is not synchronized at the base station.

Remote command:

`[ :SOURce<hw> ] :BB:W3GPP:MSTation:ADDITIONAL:TDELAY:STEP` on page 352

## 3.10 Base station settings

Base stations can be configured independently of one another. Base station 1 (BS1) also includes enhanced channels (Enhanced Channels, Realtime).

Access:

1. Select "3GPP FDD > Link Direction > Downlink / Forward".
2. Select "Base Station > BS 1/2/3/4".

The "Base Station" dialog provides the parameters for configuring the general settings of the base station and specific base station-related settings. It also contains the channel table with graphical display of the structure of the currently selected channel.

### 3.10.1 Common settings

- ▶ Select "Common".

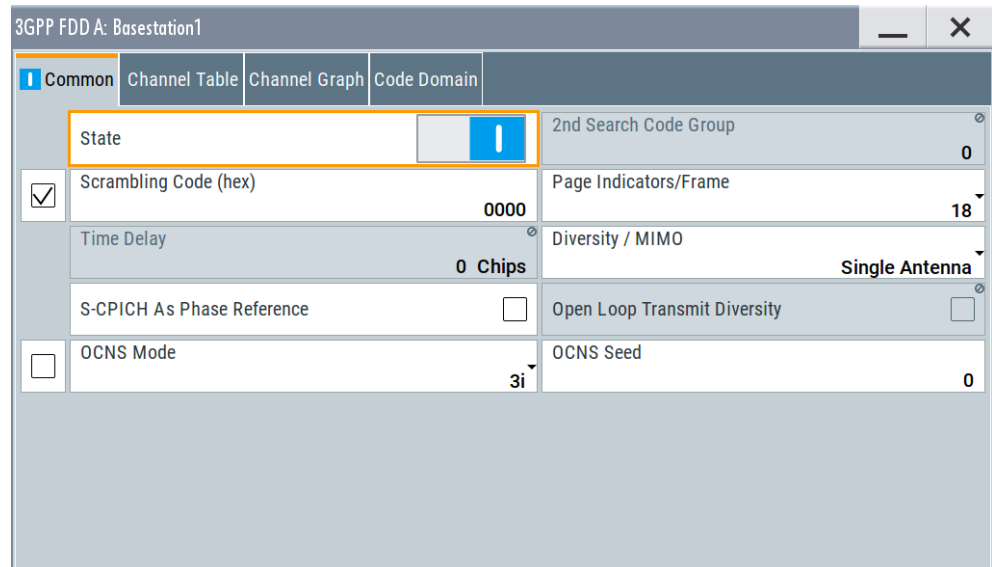

This tab comprises the general parameters required for configuring the base station.

#### State

Activates or deactivates the selected base station.

Remote command:

`[ :SOURce<hw> ] :BB:W3GPp:BSTation<st>:STATe` on page 328

#### 2<sup>nd</sup> Search Code Group

Displays the second search code group.

This parameter is specified in the table defined by the 3GPP standard. This table assigns a specific spreading code to the synchronization code symbol for every slot in the frame. The value is calculated from the scrambling code.

Remote command:

`[ :SOURce<hw> ] :BB:W3GPp:BSTation<st>:SSCG?` on page 328

#### Scrambling Code On

Activates the scrambling code, selected with the parameter [Scrambling Code \(hex\)](#).

The scrambling code can be deactivated for test purposes.

Remote command:

`[ :SOURce<hw> ] :BB:W3GPp:BSTation<st>:SCODE:STATe` on page 327

#### Scrambling Code (hex)

Sets the scrambling code and thus the base station identification.

This value is also the initial value of the scrambling code generator, see [Chapter 2.3.1, "Scrambling code generator"](#), on page 17.

To activate the scrambling code, set the check box to **On**.

Remote command:

`[ :SOURce<hw> ] :BB:W3GPP:BSTation<st>:SCODE` on page 327

### Page Indicators/Frame

Enters the number of page indicators (PI) per frame in the page indicator channel (PICH).

Remote command:

`[ :SOURce<hw> ] :BB:W3GPP:BSTation<st>:PINDicator:COUNT` on page 327

### Time Delay

For basestation BS2/3/4, sets the time delay of the signal of the selected base station compared to the signal of base station 1.

Remote command:

`[ :SOURce<hw> ] :BB:W3GPP:BSTation<st>:TDELay` on page 329

### Diversity / MIMO

Selects the antenna and the antenna configuration to be simulated.

The R&S SMBV100B supports two antenna configurations: a single-antenna system and a two-antenna system. Thus, an instrument equipped with two paths can simulate simultaneously the signals of both antennas of one two-antenna system. Moreover, for this two-antenna system, transmit diversity can be additionally activated or deactivated.

To simulate transmit diversity, a two-antenna system has to be selected and "Open Loop Transmit Diversity" has to be activated.

To configure HS-PDSCH MIMO channels, a two-antenna system has to be selected.

"Single Antenna"

The signal of single-antenna system is calculated and applied.

"Antenna 1 of 2"

Calculates and applies the output signal for antenna 1 of a two-antenna system.

"Antenna 2 of 2"

Calculates and applies the output signal for antenna 2 of a two-antenna system.

Remote command:

`[ :SOURce<hw> ] :BB:W3GPP:BSTation<st>:TDIVersity` on page 329

### S-CPICH As Phase Reference

Activates or deactivates the use of S-CPICH as reference phase.

If activated the phase of S-CPICH and the phase of all DPCHs is 180 degrees offset from the phase of P-CPICH.

Remote command:

`[ :SOURce<hw> ] :BB:W3GPP:BSTation<st>:SCPich:PREFere[nce] [:STATe]` on page 328

### Open Loop Transmit Diversity

(Enabled for two-antenna system only)

Activates/deactivates open loop transmit diversity. The antenna whose signal is to be simulated is selected with the parameter "Diversity/MIMO".

Various forms of transmit diversity are described in the 3GPP standard. Different coding is used to divide the signal between the two antennas. As a result, the receiver can decode the traffic signal from the two input signals and is less liable to fading and other interferences.

A fixed diversity scheme is assigned to each channel type:

- TSTD (time switched transmit diversity for SCH) for P-SCH, S-SCH
- STTD (space time block coding transmit antenna diversity) for all other channels, except HS-PDSCH MIMO.

The HS-PDSCH MIMO channels are precoded as described in [Chapter 2.3.14, "MIMO in HSPA+"](#), on page 30.

These two schemes are described in detail in TS 25.211.

Remote command:

`[ :SOURce<hw> ] :BB:W3GPP:BSTation<st>:TDIVersity` on page 329

`[ :SOURce<hw> ] :BB:W3GPP:BSTation<st>:OLTDiversity` on page 326

### 3.10.2 Orthogonal channel noise (OCNS) settings

With Orthogonal Channel Noise, a practical downlink signal is generated to test the maximum input levels of user equipment in accordance with standard specifications. This simulates the data and control signals of the other orthogonal channels in the downlink. 3GPP TS 25.101 contains a precise definition of the required appearance of the OCNS signal.

This section describes the provided settings. For detailed information, see [Chapter 2.3.11, "Orthogonal channel noise \(OCNS\)"](#), on page 25.

#### OCNS On

In BS1, activates OCNS channels according to the definition in the 3GPP standard.

The 3GPP specification defines different OCNS scenarios. Select the OCNS scenario with the parameter [OCNS Mode](#).

When activating OCNS and depending on the selected OCNS mode, different channel groups with different presetting are assigned, see tables in [Chapter 2.3.11, "Orthogonal channel noise \(OCNS\)"](#), on page 25. These channels cannot be edited in the channel table.

Remote command:

`[ :SOURce<hw> ] :BB:W3GPP:BSTation:OCNS:STATE` on page 283

#### OCNS Mode

Selects the scenario for activating OCNS channels. To activate the selected OCNS scenario, set the check box [OCNS > On](#).

Four different OCNS scenarios are defined in the 3GPP standard; one "standard" scenario, two scenarios for HSDPA test cases and one scenario for type 3i enhanced performance requirements tests according to 3GPP TS34.121-1 ("other user's channels"). For an overview of the provided scenarios and their settings, refer to [Chapter 2.3.11, "Orthogonal channel noise \(OCNS\)"](#), on page 25.

**Note:** If the "3i" OCNS mode is activated and the "3GPP FDD > State > On", the OCNS channels are automatically leveled in order to have total power of 0 dB for all channels of BS 1.

Remote command:

`[ :SOURCE<hw> ] :BB:W3GPP:BSTation:OCNS:MODE` on page 283

### OCNS Seed

In "OCNS mode > 3i", sets the seed for both the random processes, the power control simulation process and the process controlling the switch over of the channelization codes.

Remote command:

`[ :SOURCE<hw> ] :BB:W3GPP:BSTation:OCNS:SEED` on page 283

## 3.10.3 Channel table

The channel table allows you to configure the individual channel parameters. The structure of the currently selected channel is displayed graphically in the table header.

Access:

1. Select "3GPP FDD > Link Direction > Downlink / Forward".
2. Select "Base station > BS 1/2/3/4".
3. Select "Channel Table".

Predefined Symbols												
10												
	Channel Type	Enh/HSDPA Settings	Slot Fmt	Sym Rate /ksps	Chan Code	Power /dB	Data	DList Patt	T Offs	DPCCH Settings	State	Dom Conf
0	P-CPICH	Config...		15	0	-10.00					On	
1	S-CPICH			15	0	0.00					Off	
2	P-SCH			15		-13.00					On	
3	S-SCH			15		-13.00					On	
4	P-CCPCH	Config...		15	1	-10.00	PN 9				On	
5	S-CCPCH		0	15	3	-18.00	PN 9			150 Config...	On	
6	PICH			15	16	-18.00	Pattern	10		120	On	

The channel table contains a list of all channels available for a base station, and the associated parameters required for configuring the channel.

139 channels are available for each base station. Channels 0 to 10 are assigned to the special channels, with the allocation of channels 0 to 8 being fixed. Channels 9 and 10



can be assigned a PDSCH, a DL-DPCCH, an HS-SCCH, an E-AGCH, an E-RGCH, or an E-HICH.

Code channels 11 to 138 can be assigned a DPCH, an HS-SCCH, an HS-PDSCH (QPSK/16QAM/64QAM), an HS-PDSCH (MIMO), an E-AGCH, an E-RGCH, an E-HICH, or an F-DPCH. This makes it possible to simulate the signal of a base station that supports high-speed channels. See also [Table A-1](#)

Channels 4 and 11 to 13 of base station 1 can be generated in realtime (enhanced channels) and are highlighted in color. User-definable channel coding can be activated for these channels. Bit and block errors can be simulated. Data can be added to the data and TPC fields from data lists either at the physical level or in the transport layer.

At the physical level, a downlink DPCH consists of the DPDCH (Dedicated Physical Data Channel) and the DPCCH (Dedicated Physical Control Channel). The channel characteristics are defined by the symbol rate. The DPDCH transports the user data that is fed directly into the data field.

The DPCCH transports the control fields, i.e. TFCI (Transport Format Combination Indicator), TPC (Transmit Power Control) and Pilot field. DPDCH is grouped with DPCCH using time division multiplexing in accordance with 3GPP TS 25.211 (see [Figure 3-3](#)). The formation of a downlink reference measurement channel is described in [Chapter 3.16, "Enhanced settings for DPCHs - BS1"](#), on page 113.

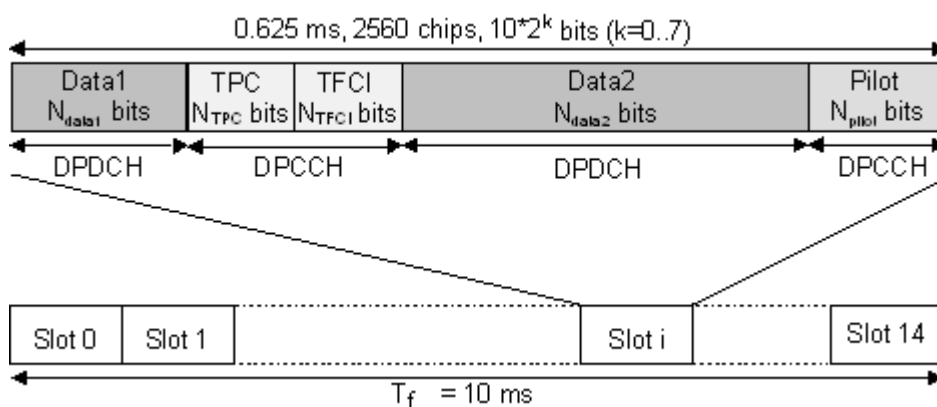

**Figure 3-3: Structure of a downlink DPCH in the time domain**

#### Multi Channel Assistant

Accesses a dialog for configuring several DPCH channels simultaneously, see [Chapter 3.23, "Multi channel assistant - BS"](#), on page 146.

Remote command:

n.a.

#### Reset All Channels

Loads the default settings for the channel table.

Remote command:

`[ :SOURCE<hw> ] :BB:W3GPP:BSTation<st>:CHANNEL:PRESet` on page 284

#### Preset HSDPA H-Set

(This feature is available for BS 1 only.)

Calls the default settings of the channel table for the HSDPA H-Set mode.

Channels 12 to 17 are preset for HSDPA H-Set 1.

Remote command:

`[ :SOURCE<hw> ] :BB:W3GPp:BSTation<st>:CHANnel:HSDPa:HSET:PRESet`

on page 284

### Channel Number

Displays the consecutive channel numbers from 0 to 138.

All the rows are always displayed, even if the channels are inactive. They are switched on and off by the "On/Off" button in the "State" column.

Remote command:

n.a.

(selected via the suffix to the keyword `:CHANnel<n>`)

### Channel Type

Selects channel type.

The channel type is fixed for channel numbers 0...8; for the remaining channel numbers, the choice lays between the relevant standard channels and the high-speed channels.

The first 11 channels are reserved for special channels.

Remote command:

`[ :SOURCE<hw> ] :BB:W3GPp:BSTation<st>:CHANnel<ch0>:TYPE` on page 316

### Enhanced Settings / HSDPA Settings

(Enhanced Settings are available for BS1 only.)

Accesses the dialog for configuring the enhanced channels of BS1 or the dialog for configuring the high-speed channels for all base stations.

- **Enhanced Settings**

The channel state, "Enhanced On/Off", is displayed in different colors.

Enhanced channels are generated in real time. Channel coding in accordance with the 'Reference Measurement Channels' definition in TS 25.101, TS 25.104 and TS 25.141 can be activated. Any other user-defined coding can also be configured and stored.

If data lists are used as the data sources for data fields and TPC fields, it is possible to load external data. You can load, for example:

- User information from a higher layer
- TPC lists and use them to generate longer, non-repetitive power profiles
- Data lists with artificial bit errors or block errors to the CRC checksum to test the BER/BLER testers that are integrated in the BS.

The enhanced settings dialog is different for the P-CCPCH and the DPCHs (see [Chapter 3.16, "Enhanced settings for DPCHs - BS1"](#), on page 113 and [Chapter 3.15, "Enhanced settings for P-CCPCH - BS1"](#), on page 111).

- **HSDPA Settings**

The available settings and indications of the HSDPA settings dialog depend on the selected high-speed channel type HS-SCCH, HS-PDSCH (QPSK), HS-PDSCH (QAM) or HS-PDSCH (MIMO).

See [Chapter 3.12, "HSDPA settings - BS"](#), on page 88.

Remote command:  
n.a.

### Slot Format

Enters the slot formats for the selected channel.

The range of values depends on the channel selected. For DPCH channels, for example, the slot formats are 0 to 16.

For F-DPCH channels, the slot formats 1 to 9 are enabled only for instruments equipped with additional option R&S SMBVB-K83. The difference between the F-DPCH slot formats is the position of the 2 bits TPC field.

A slot format defines the complete structure of a slot made of data and control fields and includes the symbol rate.

Parameters set via the slot format can subsequently be changed individually.

The structure of the channel currently selected is displayed in a graphic above the channel table (slot structure).

Remote command:

`[ :SOURce<hw> ] :BB:W3GPP:BSTation<st>:CHANnel<ch0>:SFORmat`  
on page 315

### Symbol Rate

Sets the symbol rate of the selected channel. The range of values depends on the channel selected.

A change in the symbol rate can lead to a change in the slot format and vice versa.

Remote command:

`[ :SOURce<hw> ] :BB:W3GPP:BSTation<st>:CHANnel<ch0>:SRATE` on page 315

### Channelization Code

Enters the channelization code (formerly the spreading code number).

The code channel is spread with the set channelization code (spreading code). The range of values of the channelization code depends on the symbol rate of the channel.

The standard assigns a fixed channelization code to some channels (P-CPICH, for example, always uses channelization code 0).

The range of values runs from 0 to  $((\text{Chip Rate}/\text{Symbol Rate}) - 1)$ , where the Chip Rate is 3.84Mcps.

Remote command:

`[ :SOURce<hw> ] :BB:W3GPP:BSTation<st>:CHANnel<ch0>:CCODE` on page 286

### Power

Sets the channel power in dB.

The power entered is relative to the powers of the other channels. If "3GPP > Adjust Total Power to 0 dB" is executed, all the power data is relative to 0 dB.

The set "Power" value is also the start power of the channel for "Misuse TPC", "Dynamic Power Control" and the power control sequence simulation of the OCNS mode 3i channels.

**Note:** The maximum channel power of 0 dB applies to non-blanked channels (duty cycle 100%).

With blanked channels, the maximum value can be increased to values greater than 0 dB. Where the maximum value is calculated as:

$$10 \cdot \log_{10} 1 / \text{duty\_cycle}$$

Remote command:

`[ :SOURce<hw> ] :BB:W3GPp:BSTation<st>:CHANnel<ch0>:POWER` on page 315

### Data

Selects data source.

The following standard data sources are available:

- "All 0, All 1"  
An internally generated sequence containing 0 data or 1 data.
- "PNxx"  
An internally generated pseudo-random noise sequence.
- "Pattern"  
An internally generated sequence according to a bit pattern.  
Use the "Pattern" box to define the bit pattern.
- "Data List/Select DList"  
A binary data from a data list, internally or externally generated.  
Select "Select DList" to access the standard "Select List" dialog.
  - Select the "Select Data List > navigate to the list file \*.dm\_iqd > Select" to select an existing data list.
  - Use the "New" and "Edit" functions to create internally new data list or to edit an existing one.
  - Use the standard "File Manager" function to transfer external data lists to the instrument.

See also:

- Section "Modulation Data" in the R&S SMBV100B user manual.
- Section "File and Data Management" in the R&S SMBV100B user manual.
- Section "Data List Editor" in the R&S SMBV100B user manual

Remote command:

`[ :SOURce<hw> ] :BB:W3GPp:BSTation<st>:CHANnel<ch0>:DATA` on page 286

`[ :SOURce<hw> ] :BB:W3GPp:BSTation<st>:CHANnel<ch0>:DATA:PATtern`  
on page 287

`[ :SOURce<hw> ] :BB:W3GPp:BSTation<st>:CHANnel<ch0>:DATA:DSElect`  
on page 287

### Data Config

(This feature is available for BS1 with active channel coding only.)

Accesses a dialog for configuring the data sources of subchannels in the transport layer, see [Chapter 3.16, "Enhanced settings for DPCHs - BS1"](#), on page 113.

Remote command:

n.a.

### Timing Offset

Sets the timing offset ( $T_{\text{Offset}}$ ).

The timing offset determines the shift of the source symbols before interleaving.

The absolute starting time of the frame (slot 0) is shifted relative to the start of the scrambling code sequence by the  $\text{timing offset} * 256 \text{ chips}$ . This means that whatever the symbol rate, the resolution of the timing offset is always 256 chips.

This procedure is used to reduce the crest factor. To obtain a lower crest factor, for example, a good offset from channel to channel is 1. For example, for DPCH11 a timing offset 0, for DPCH12 a timing offset 1, for DPCH13 a timing offset 2.

The illustration below shows the effect of the timing offset parameter. For various scenarios, the scrambling code sequence is shown in time relation to the data slots and to a reference time  $t_0$ . The reference time  $t_0$  is the starting time from that the signal is calculated in the instrument.

- Timing offset is not used ( $T_{\text{Offset}} = 0$ ).  
The beginning of the frame (slot 0) and the beginning of the scrambling code period are synchronous with starting point  $t_0$ .
- Timing offset is used ( $T_{\text{Offset}} > 0$ ).  
The absolute starting time of the frames (slot 0) is shifted relative to the reference time  $t_0$  by  $T_{\text{Offset}} * 256 \text{ chips}$ . The beginning of the scrambling code sequence is still synchronous with reference time  $t_0$ . The beginning of the scrambling code period and the frame (slot 0) are no longer synchronous.

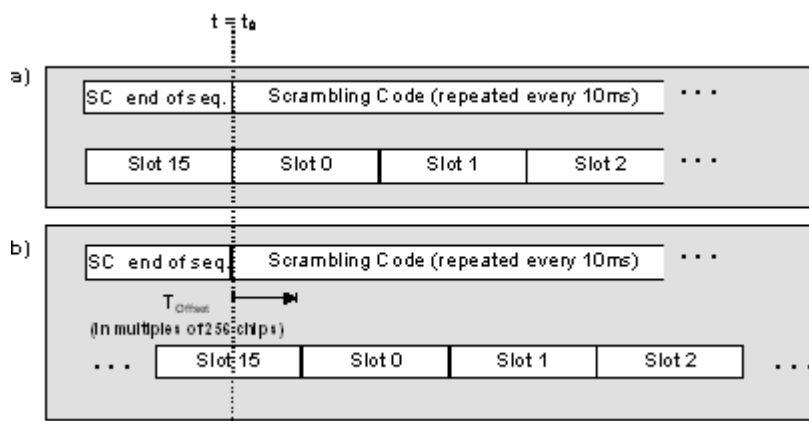

Remote command:

```
[ :SOURCE<hw> ] :BB:W3GPP:BSTation<st>:CHANNEL<ch0>:TOFFset
on page 316
```

### DPCCH Settings

Access a dialog for configuring the control fields of the selected channel, see [Chapter 3.19, "DPCCH settings - BS channel table"](#), on page 131

The selected slot format predetermines the setting of the control fields. So a change is also made to the control fields by changing the slot format and vice versa.

Remote command:

n.a.

### Channel State

Activates or deactivates the channel.

Remote command:

`[ :SOURce<hw> ] :BB:W3GPP:BSTation<st>:CHANnel<ch0>:STATe` on page 316

### Domain Conflict, Resolving Domain Conflicts

Displays whether the channel has a code domain conflict with one of the channels lying above it (with a lower channel number). A special symbol marks a conflict and the column is colored soft orange. If there is no conflict, the column is colored soft blue.

The instrument helps you to resolve code domain conflicts by automatically adapting the channelization code of the channels involved.

To access the required function, in the "3GPP FDD > Base station > Channel Table" select the conflict symbol and trigger "Resolve Domain Conflicts".



**Tip:** Use the "Code Domain" to visualize the graphical display of code domain assignment by all the active code channels (see [Chapter 3.10.5, "Code domain graph - BS"](#), on page 79).

Refer to [Chapter 4, "How to work with the 3GPP FDD option"](#), on page 251 for step-by-step description.

Remote command:

`[ :SOURce<hw> ] :BB:W3GPP:BSTation<st>:DCONflict [ :STATe ] ?` on page 326

`[ :SOURce<hw> ] :BB:W3GPP:BSTation<st>:DCONflict:RESolve` on page 326

## 3.10.4 Channel graph - BS

The channel graph display shows the active code channels.

1. To access the base station channel graph, select "3GPP FDD > Link Direction > Downlink / Forward".
2. Select "Basestation > BS 1/2/3/4".

3. Select "Channel Graph".

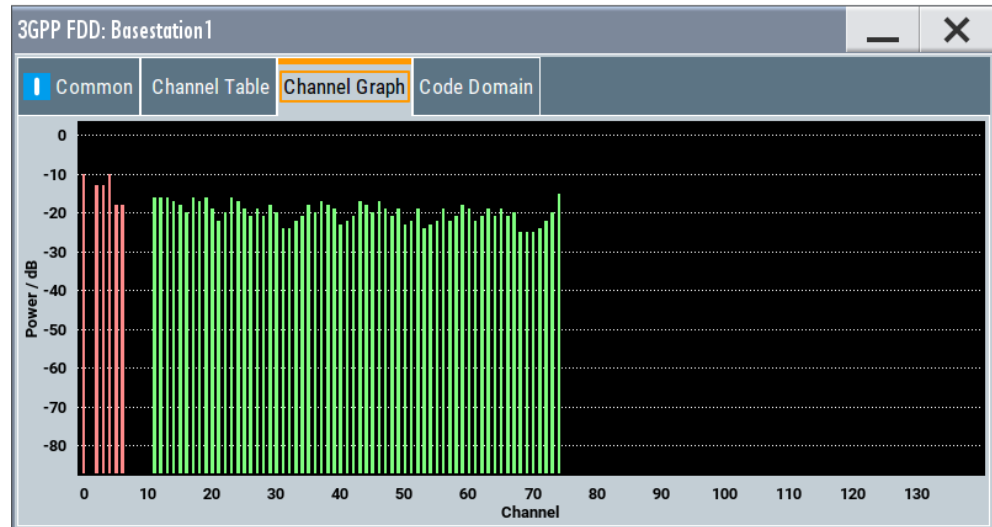

The channel number is plotted on the X-axis. The red bars represent the special channels (P-CPICH to DL-DPCCH), the green bars the other channels. The height of the bars shows the relative power of the channel

### 3.10.5 Code domain graph - BS

The channelization codes are taken from a code tree of hierarchical structure (see [Figure 3-4](#)).

The higher the spreading factor, the smaller the symbol rate and vice versa. The product of the spreading factor and symbol rate is constant and always yields the chip rate.

The outer branches of the tree (right-most position in the figure) indicate the channelization codes for the smallest symbol rate (and thus the highest spreading factor). Channelization codes with smaller spreading factor are contained in the codes with larger spreading factor in the same code branch. When using such competitive channelization codes at the same time, the signals of associated code channels are mixed such that they can no longer be separated in the receiver. Orthogonality is then lost.

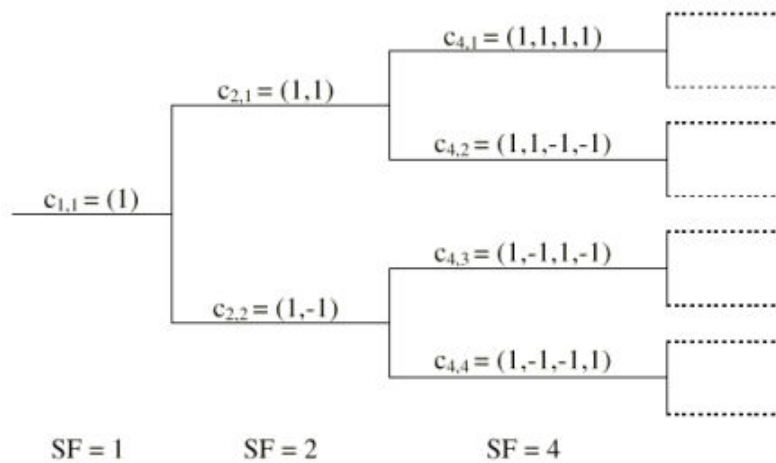

Figure 3-4: Code tree of channelization codes

#### Example:

If code  $c_{2,1}$  is being used, the remaining branch with  $c_{4,1}$  and  $c_{4,2}$  is blocked.

The domain of a certain channelization code is the outer branch range (with minimum symbol rate and max. spreading factor). It is based on the channelization code selected in the code tree. Using a spreading code means that its entire domain is used.

At a chip rate of 3.84 Mcps, the domain ranges from 0 to 511

$$= \frac{\text{Chip\_rate}}{\text{min\_Symbol\_rate}} - 1 = \frac{3.84 \text{ Mcps}}{7.5 \text{ ksps}} - 1$$

#### Understanding the displayed information

The "Code Domain" display indicates the assigned code domain. The channelization code is plotted at the X-axis, the colored bars indicate coherent code channels. The colors are assigned to fixed symbol rates, the allocation is shown below the graph. The relative power can be taken from the height of the bar.



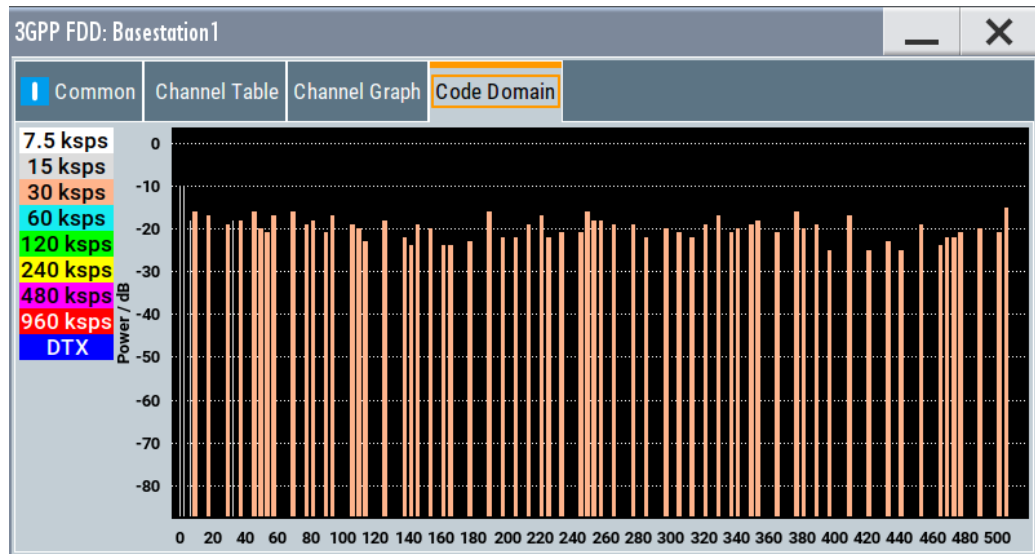

If the current settings result in a code domain conflict where the code domains of the active channels intersect, the code domain conflict is indicated by overlapping bars.

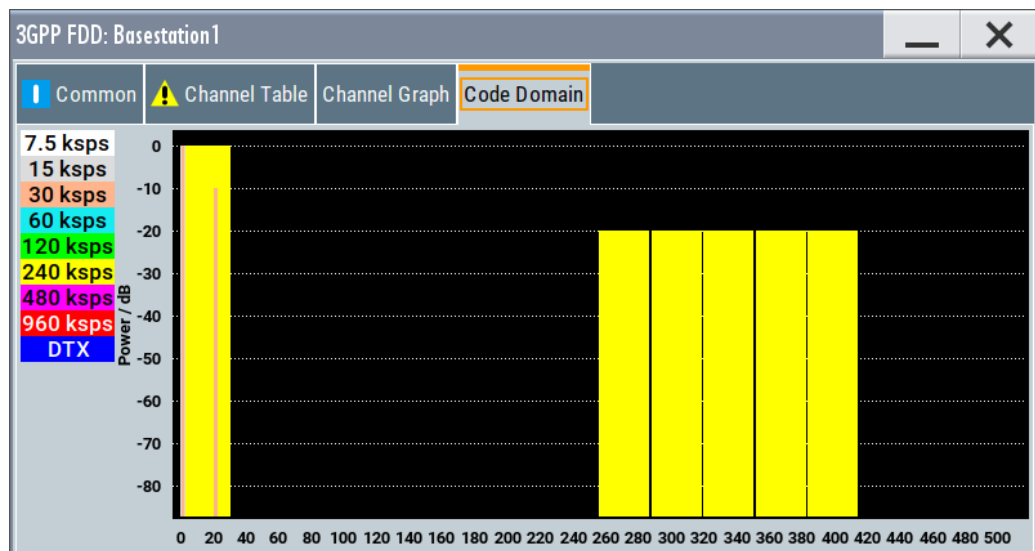

The occupied code domain of a channel is calculated as follows:

$$\text{Domain\_Factor} = \frac{\text{current\_symbol\_rate}}{\text{min\_symbol\_rate}(=7.5\text{ksp/s})}$$

As follows:

"Lower domain limit" = current channelization code number \* domain factor

"Upper domain limit" = lower domain limit + domain\_factor - 1.

**Example:**

Channel with symbol rate 30 ksps and channelization code 10:

Domain factor =  $30/7.5 = 4$ ,

Lower domain limit =  $10 \times 4 = 40$ ,

Upper domain limit =  $40 + 4 - 1 = 43$ .

The channel occupies the code domain 40 to 43.



Refer to [Chapter 4.1, "Resolving domain conflicts"](#), on page 251 for step-by-step description.

## 3.11 Compressed mode

(This feature is available for BS 2...4 and UE 2...4 only.)

To enable handover of a mobile station from a 3GPP FDD base station/user equipment to another base station/user equipment, (3GPP FDD, 3GPP TDD, GSM or E-UTRA) at a different frequency, transmission and reception of the 3GPP FDD signal must be interrupted for a short time. During this time, the mobile station changes to the frequency of the new base station, for example to measure the receive level of this station or read system information.

To transmit a consistently high data volume also in the remaining (shorter) period of time, the data is compressed. This can be done by halving the spreading factor (SF/2 method) or reducing error protection (puncturing method). In both cases, transmit power in the ranges concerned is increased to maintain adequate signal quality.

Apart from these two methods, there is also the method of "higher layer scheduling". With this method, transmission of the data stream is stopped during the transmission gap. This method is suitable for packet-oriented services; it involves no power increase (power offset) in the active ranges.

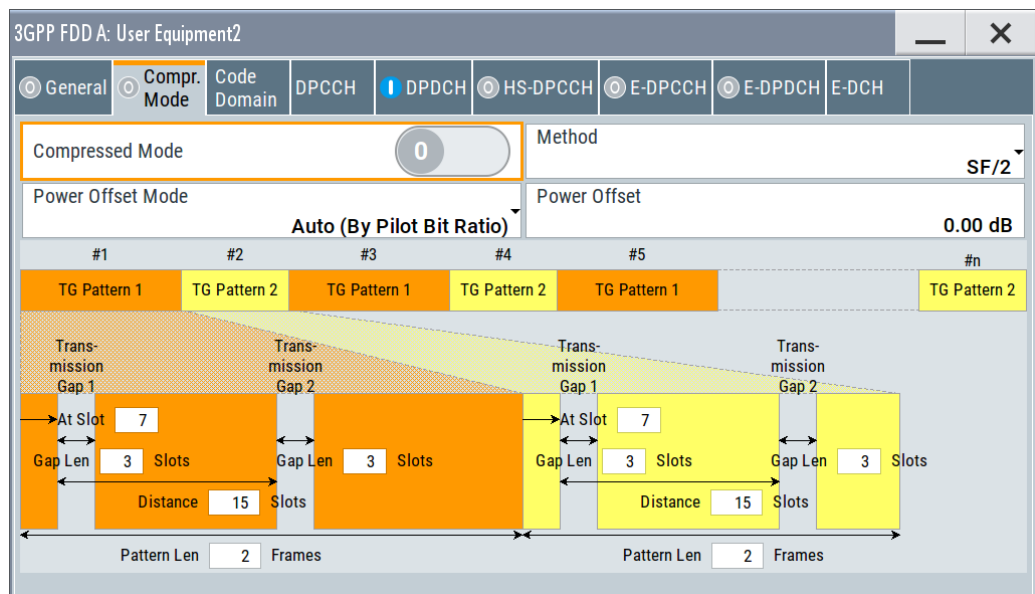
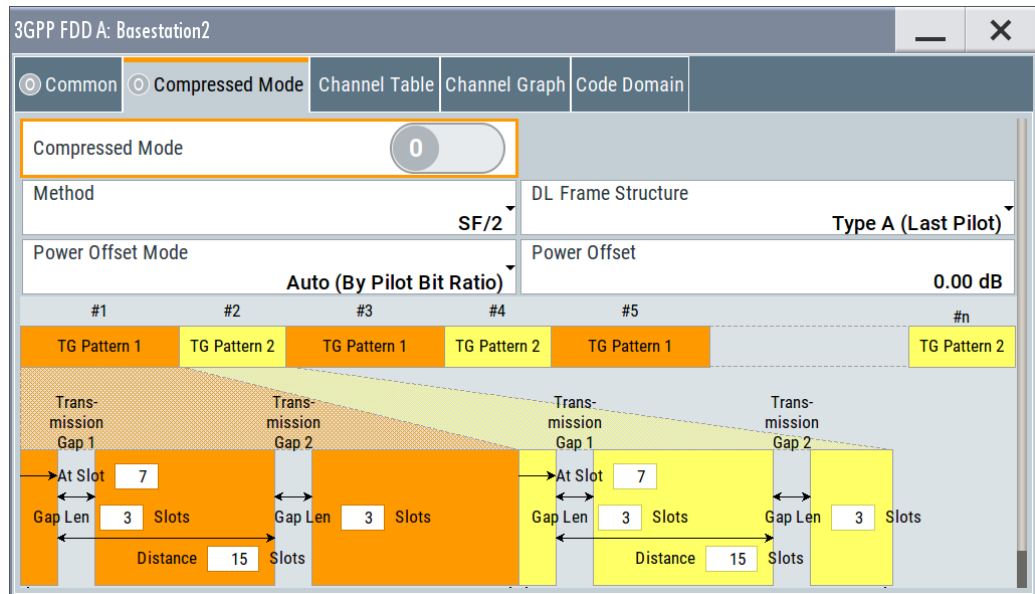

### 3.11.1 Compressed mode general settings

#### Compressed Mode State

Activates compressed mode.

The compressed mode is configured in [Chapter 3.11, "Compressed mode"](#), on page 82.

Remote command:

`[ :SOURCE<hw> ] :BB:W3Gpp:BSTation<st>:CMODE:STATE` on page 326

`[ :SOURCE<hw> ] :BB:W3Gpp:MSTation<st>:CMODE:STATE` on page 357

**Compressed Mode Method - UE**

Selects compressed mode method.

"Higher layer scheduling" The data is compressed by stopping the transmission of the data stream during the transmission gap.

"SF/2" The data is compressed by halving the spreading factor.

Remote command:

[\[:SOURCE<hw>\]:BB:W3GPP:MSTation<st>:CMODE:METHOD](#) on page 356

**Compressed Mode Method - BS**

Selects compressed mode method.

"Puncturing" The data is compressed by reducing error protection.

"Higher layer scheduling" The data is compressed by stopping the transmission of the data stream during the transmission gap.

"SF/2" The data is compressed by halving the spreading factor. This method can be demonstrated in the code domain graph. The graph is split into two windows. The upper window shows the code domain assignment with non-compressed slots, the lower window with compressed slots. It can be recognized clearly that the DPCH bars in the lower window are wider, which is due to the reduction of the spreading factor of these channels. The other channels (e.g. CPICH) have the same width in both halves.

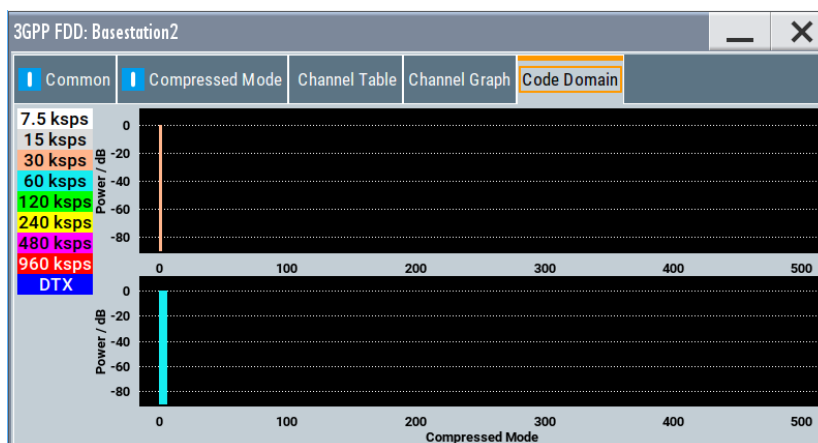

Remote command:

[\[:SOURCE<hw>\]:BB:W3GPP:BSTation<st>:CMODE:METHOD](#) on page 323

**DL Frame Structure - BS**

Selects frame structure. The frame structure determines the transmission of TPC and pilot field in the transmission gaps.

For 3GPP FDD radio communication to operate, the mobile station receiver requires information in the pilot field for synchronization and channel estimation and in the power control field TPC for control of the mobile station transmit power.

To keep the period during which no channel estimation takes place as short as possible, the pilot is sent in the last slot of each transmission gap.

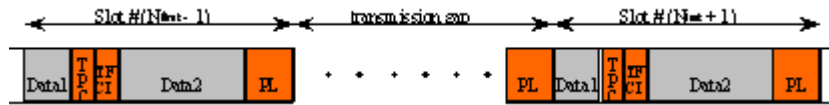

Optionally, the first TPC field of the transmission gap can be sent in addition.



"Type A (Last Pilot)" The pilot field is sent in the last slot of each transmission gap.

"Type B (First TPC, Last Pilot)" The pilot field is sent in the last slot of each transmission gap. The first TPC field of the transmission gap is sent in addition.

Remote command:

[\[:SOURCE<hw>\]:BB:W3Gpp:BSTation<st>:CMODE:DLFStructure](#) on page 323

### Power Offset Mode

Selects power offset mode.

The compressed slots can be sent with a power offset, i.e. at an increased power level.

"Auto (By Pilot Bit Ratio)" The power offset is obtained as the relation between the Number of pilots bits of non-compressed slots and the Number of pilot bits by compressed slots.

"User" The power offset is defined manually. The value is input in entry field Power offset.

Remote command:

[\[:SOURCE<hw>\]:BB:W3Gpp:BSTation<st>|MSTation<st>:CMODE:POMode](#) on page 325

### Power Offset

Defines power offset. The entered value is only valid for "Power Offset Mode User".

Remote command:

[\[:SOURCE<hw>\]:BB:W3Gpp:BSTation<st>|MSTation<st>:CMODE:POFFset](#) on page 325

## 3.11.2 Compressed mode configuration graph

The remaining parameters of the compressed mode are set in the configuration graph. The graph displays the distribution of transmission gaps in a compressed mode signal.

The signal generated can be divided into three subranges.

### 3.11.2.1 Transmission gaps

A transmission gap has a maximum length of 14 slots. Since at least eight active slots must be sent per frame, gaps comprising seven slots and more have to be distributed over two neighboring frames.

The transmitted signal consists of max. two patterns that are sent alternately. Each pattern comprises two transmission gaps.

The graph includes all parameters necessary to define the transmission gaps in the signal.



The settings in the graph are also valid for the compressed mode graph of the user equipment with the same number. For example, setting a distance of 9 slots for base station 4 also sets the distance to 9 slots for user equipment 4.

The parameters below are interrelated in many ways. For example, the transmission gap distance must be selected so that no frame contains more than one gap. In the event of an invalid entry, the next valid value is automatically set. If the entry is valid but changes the valid range for another parameter, the setting of the parameter is adapted.

#### At Slot:

Transmission gap slot number.

Remote command:

`[ :SOURCE<hw> ] :BB:W3GPp:BSTation<st>:CMODE:PATtern<ch>:TGSN`  
on page 324

`[ :SOURCE<hw> ] :BB:W3GPp:MSTation<st>:CMODE:PATtern<ch>:TGSN`  
on page 357

#### Gap Len:

Transmission gap lengths.

Remote command:

`[ :SOURCE<hw> ] :BB:W3GPp:BSTation<st>:CMODE:PATtern<ch>:TGL<di>`  
on page 324

`[ :SOURCE<hw> ] :BB:W3GPp:MSTation<st>:CMODE:PATtern<ch>:TGL<di>`  
on page 356

#### Distance

Transmission gap distance.

Remote command:

`[ :SOURCE<hw> ] :BB:W3GPp:BSTation<st>:CMODE:PATtern<ch>:TGD`  
on page 324

`[ :SOURCE<hw> ] :BB:W3GPp:MSTation<st>:CMODE:PATtern<ch>:TGD`  
on page 356

**Pattern Len:**

Transmission gap pattern length. The input range is 1 ... 100 frames for pattern 1 and 0 ... 100 frames for pattern 2. Thus, it is possible to configure transmission gap pattern with only one pattern.

Remote command:

`[ :SOURCE<hw> ] :BB:W3GPP:BSTation<st>:CMODE:PATTERN<ch>:TGPL`  
on page 324

`[ :SOURCE<hw> ] :BB:W3GPP:MSTation<st>:CMODE:PATTERN<ch>:TGPL`  
on page 357

**3.11.2.2 Compressed ranges**

All slots of a frame that are not blanked are compressed. If the transmission gap is transmitted within one frame (single-frame method), an envelope as shown by the diagram on [Figure 3-5](#) is obtained:

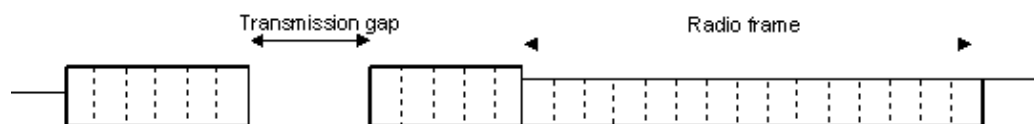

*Figure 3-5: Envelope of compressed mode signal with single-frame method*

If the transmission gap is distributed over two neighboring frames, all slots of the two frames that are not blanked are compressed (see [Figure 3-6](#)):



*Figure 3-6: Envelope of compressed mode signal with double-frame method*

A different slot format, usually with a higher number of pilot bits, is used in the compressed ranges.

The transmit power can be increased ("Power Offset Mode") automatically or manually by defining a power offset.

**3.11.2.3 Non-compressed ranges**

Frames containing no transmission gaps are sent with the same slot format and the same power as in the non-compressed mode.

## 3.12 HSDPA settings - BS

### Generation modes of the high-speed channels

The high-speed channels can be generated either *continuously* as defined in test model 5, in packet mode or in H-Set mode according to TS 25.101, annex A.7.

In *packet mode*, the start of the channel and the distance between the HSDPA packets can be set. The packet transmissions can start in one of the first five subframes (0 to 4). A subframe has the same length as a packet and is three slots long. An HS-SCCH starts at the beginning of the selected subframe, an HS-PDSCH starts with an offset of two slots to the selected subframe. The active parts of the HS-SCCH and the HS-PDSCH for a specific subframe setting differ by the slot offset of the HS-PDSCH.

#### Example:

Setting subframe 1

HS-SCCH: slot 3 to 5 active

HS-PDSCH: slot 5 to 7 active.

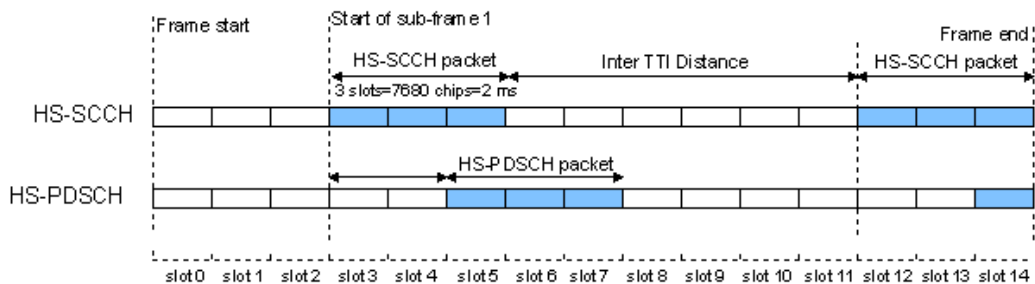

Figure 3-7: Timing diagram for the HS-SCCH and the associated HS-PDSCH, packet subframe 1 mode and inter-TTI distance = 3

In *H-Set mode*, the first packet is sent in the HS-SCCH subframe 0. Up to 15 HSDPA channels are coupled to be used in the fixed reference channels. The number of coupled channels depends on the selected H-Set. Channel coding is always performed over a certain number of bits. The resulting packets are distributed evenly over one subframe of all HS-PDSCH channelization codes. Therefore, the data stream is not assigned to a defined channel but to all coupled channels.

### 3.12.1 Enhanced HSDPA mode settings

Access:

1. Select "Baseband > 3GPP FDD > Link Direction > Downlink / Forward".
2. In the "Basestations" tab, select "Select Basestations > BS 1".
3. In the "Channel Table" tab, select e.g. "Channel Type > HS-PDS, QPSK 16QAM".
4. Select "Enh/HSDPA Settings > Config...".



5. Select "HSDPA-Mode > Subframe 1".

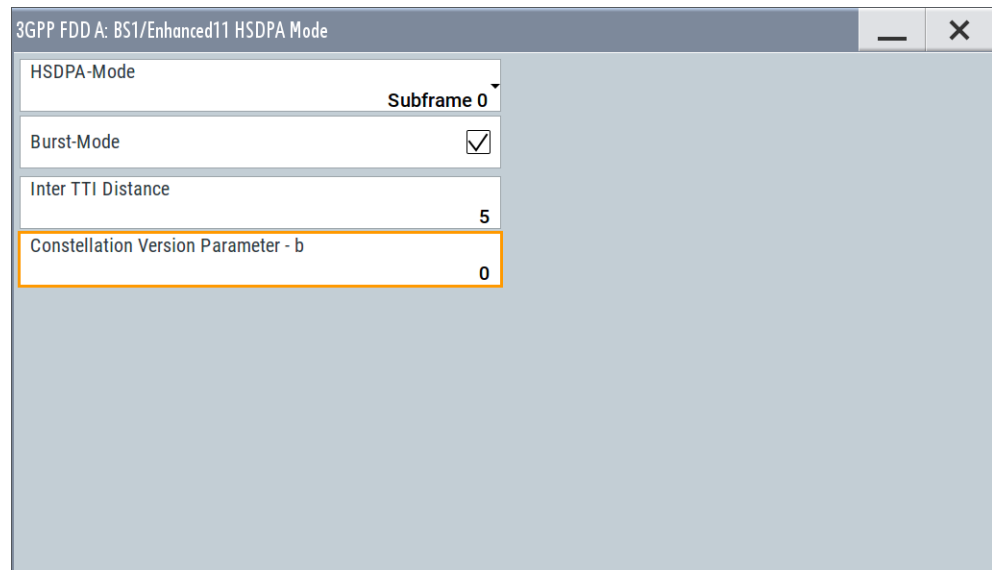

The available settings and indications in this dialog depend on the selected HSDPA mode and channel type.

### HSDPA Mode

Selects the HSDPA mode.

- |                                 |   |
|---------------------------------|---|
| "Continuous"                    | The high-speed channel is generated continuously. This mode is used in test model 5 and 6.  |
| "Subframe 0  <br>1   2   3   4" | The high-speed channel is generated in packet mode. The start of the channel is set by selecting the subframe in which the first packet is sent. The distance between subsequent packets is set with parameter "Inter TTI Distance".                                  |
| "H-Set"                         | (Available for BS1 and HS-SCCH only.)<br>The high-speed channel is generated in packet mode. The first packet is sent in the HS-SCCH subframe 0. The number of the coupled channel in the H-Set can be changed with the parameter "Number of HS-PDSCH Channel Codes". |

Remote command:

```
[ :SOURCE<hw> ] :BB:W3GPp:BSTation<st>:CHANnel<ch0>:HSDPa:MODE
```

on page 314

### Burst Mode

Activates/deactivates burst mode. The signal is bursted when on, otherwise dummy data are sent during transmission brakes.

Remote command:

```
[ :SOURCE<hw> ] :BB:W3GPp:BSTation<st>:CHANnel<ch0>:HSDPa:BMODE [ :  
STATE ] on page 297
```

**Inter TTI Distance (H-Set)**

(Available for "subframe x")

Selects the distance between two packets in HSDPA packet mode.

The distance is set in number of sub-frames (3 slots = 2 ms). An "Inter TTI Distance" of 1 means continuous generation.

Example:  
 Inter TTI Distance: 3  
 HARQ Processes: 2  
 => Signaling Pattern Stream 1: 0,-,-,1,-,-  
 Signaling Pattern Stream 2: 2,-,-,3,-,-

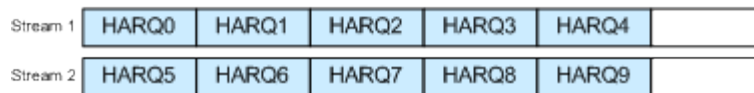

Inter TTI Distance: 1  
 HARQ Processes: 5  
 => Signaling Pattern: 0,1,2,3,4,-  
 Signaling Pattern: 5,6,7,8,9,-

**Figure 3-8: Example: Inter TTI Distance in HSDPA H-Set Mode**

Remote command:

```
[ :SOURCE<hw> ] :BB:W3GPP:BSTation<st>:CHANnel<ch0>:HSDPa:TTIDistance
```

on page 314

**Constellation Version Parameter b - BS**

(Available for "HS-PDSCH 16QAM" and "64QAM" only)

Switches the order of the constellation points of the 16QAM or 64QAM mapping.

The rearrangement is done according to 3GPP TS25.212.

Remote command:

```
[ :SOURCE<hw> ] :BB:W3GPP:BSTation<st>:CHANnel<ch0>:HSDPa:CVPB
```

on page 297

**3.12.2 MIMO configuration**

The parameters in this section are available for instruments equipped with option R&S SMBVB-K83, BS1 and Channel Type HS-PDSCH (MIMO) only (see "Diversity / MIMO" on page 70).

Access:

1. Select "Baseband > 3GPP FDD > Link Direction > Downlink / Forward".
2. In the "Base Stations" tab, select "Select Base Stations > BS 1".

3. In the "Common" tab, select "Diversity / MIMO > Antenna 1/2 of 2".
4. In the "Channel Table" tab, select "Channel Type > HS-PDS MIMO".
5. Select "Enh/HSDPA Settings > Config...".
6. Select "HSDPA-Mode > Subframe 1".

The available settings and indications in this dialog depend on the selected HSDPA mode and channel type.

The screenshot shows a configuration window titled "3GPP FDD: BS1/Enhanced47 HSDPA Mode". It contains several settings:

- HSDPA-Mode:** Subframe 1
- Burst-Mode:**
- Inter TTI Distance:** 5
- MIMO Settings:** Modulation tab is selected.
- Stream 1:** Modulation is set to 64 QAM.
- Stream 2:** Modulation is set to QPSK.
- Constellation Version Parameter - b:** 0

### Precoding Weight Pattern (w2)

Sets the precoding weight parameter w2 for MIMO precoding.

The values of the weight parameters w1, w3 and w4 are calculated based on the value for w2 (see [Chapter 2.3.14, "MIMO in HSPA+",](#) on page 30).

Remote command:

```
[ :SOURCE<hw> ] :BB:W3Gpp:BSTation<st>:CHANnel<ch0>:HSDPa:MIMO:
PWPattern on page 313
```

### Stream 2 Active Pattern

Enables/disables a temporal deactivation of stream 2 per TTI in form of sending pattern.

The stream 2 sending pattern is a sequence of max 16 values of "1" (enables stream 2 for that TTI) and "-" (disabled stream 2 for that TTI).

Remote command:

```
[ :SOURCE<hw> ] :BB:W3Gpp:BSTation<st>:CHANnel<ch0>:HSDPa:MIMO:
STAPattern on page 313
```

### Modulation Stream 1/2 (HS-PDSCH MIMO)

Sets the modulation for stream 1 and respectively stream 2 to QPSK, 16QAM or 64QAM.

Remote command:

[ :SOURce<hw> ] :BB:W3GPP:BSTation<st>:CHANnel<ch0>:HSDPa:MIMO:MODulation<di> on page 313

#### Constellation Version Parameter b Stream 1/2 - BS

Switches the order of the constellation points of the 16QAM or 64QAM mapping.

The rearrangement is done according to 3GPP TS25.212.

Remote command:

[ :SOURce<hw> ] :BB:W3GPP:BSTation<st>:CHANnel<ch0>:HSDPa:MIMO:CVPB<di> on page 312

## 3.13 HSDPA H-Set mode settings - BS



The enhanced HSDPA H-Set mode settings are available for BS1, HS-SCCH and HSDPA Mode set to H-Set only.

Access:

1. Select "3GPP FDD > Link Direction > Downlink".
2. Select "3GPP FDD > Base Stations > Select Base Station > BS1".
3. In the "Base Station 1" dialog, select "Channel Table > Preset to HSDPA H-Set".
4. In the "Channel Table", select "Channel#12 HS-SCCH > Enhanced Settings > Config".

### 3.13.1 HSDPA H-Set general settings

3GPP FDD: BS1/Enhanced12 HSDPA Mode	
HSDPA-Mode	Subframe 3
Burst-Mode	<input checked="" type="checkbox"/>
Inter TTI Distance	3

Provided are the following settings:

#### HSDPA Mode

Selects the HSDPA mode.

"Continuous" The high-speed channel is generated continuously. This mode is used in test model 5 and 6.

- "Subframe 0 | 1 | 2 | 3 | 4" The high-speed channel is generated in packet mode. The start of the channel is set by selecting the subframe in which the first packet is sent. The distance between subsequent packets is set with parameter "Inter TTI Distance".
- "H-Set" (Available for BS1 and HS-SCCH only.) The high-speed channel is generated in packet mode. The first packet is sent in the HS-SCCH subframe 0. The number of the coupled channel in the H-Set can be changed with the parameter "Number of HS-PDSCH Channel Codes".

Remote command:

`[ :SOURce<hw> ] :BB:W3GPp:BSTation<st>:CHANnel<ch0>:HSDPa:MODE`  
on page 314

#### Burst Mode

Activates/deactivates burst mode. The signal is bursted when on, otherwise dummy data are sent during transmission brakes.

Remote command:

`[ :SOURce<hw> ] :BB:W3GPp:BSTation<st>:CHANnel<ch0>:HSDPa:BMODE [ :STATE ]` on page 297

### 3.13.2 H-Set configuration common settings



The parameters in this section are available for BS1 and HSDPA H-Set Mode only.

#### Predefined H-Set

Selects the H-Set and the modulation according to TS 25.101, annex A.7 .

**Table 3-5: Following combinations are possible:**

H-Set	Modulation
1, 2, 3, 6, 10	QPSK 16QAM
4, 5, 7, 12	QPSK
8	64QAM
9	16QAM (stream 1) QPSK (stream 2)
11	64QAM (stream 1) 16QAM (stream 2)
User	-

**Note:** Option: R&S SMBVB-K83 for H-Sets 7 to 9 and H-Set 11, where H-Set 9 and H-Set 11 are available only for enabled two-antenna system (see "Diversity / MIMO" on page 70).

Several parameters are automatically set, depending on the selection made for the parameter "H-Set". However, it is also possible to change these parameters. In this case, the value of the parameter "H-Set" is automatically set to User.

**Note:** Use the predefined settings to let the instrument generate a signal equal to the one generated by an instrument equipped with older firmware.

Remote command:

```
[ :SOURce<hw> ] :BB:W3GPp:BSTation<st>:CHANnel<ch0>:HSDPa:HSET:
PREDeFined on page 303
```

### Advanced Mode (requires ARB)

Activates/deactivates the advanced mode in which the H-Set is generated by the ARB. The parameter can be configured only for H-Sets 1 - 5. For H-Sets 6 to 12 and User, it is always enabled.

For an H-Set calculated in arbitrary waveform mode, it is critical to set an appropriate "Current ARB Sequence Length". An appropriate sequence length is required for the generation of signals without unwanted artifacts when pre-calculated sequences are repeated cyclically. In particular, the HARQ cycles have to terminate completely before restarting the signal.

Assistance in setting an appropriate sequence length is provided by the parameter "Suggested ARB Sequence Length" and the "Adjust" button. When working in Advanced Mode, it is recommended to adjust the current ARB sequence length to the suggested one.

Remote command:

```
[ :SOURce<hw> ] :BB:W3GPp:BSTation<st>:CHANnel<ch0>:HSDPa:HSET:
AMODE on page 297
[ :SOURce<hw> ] :BB:W3GPp:BSTation<st>:CHANnel<ch0>:HSDPa:HSET:
SLENgth? on page 307
```

### ARB Seq Length

Displays the suggested and current ARB sequence length.

The "Suggested ARB Sequence Length" is the calculated minimum length that depends on several parameters: TTI distance, number of HARQ processes, HARQ cycles, HARQ mode, RV parameter sequence, HS-SCCH Type, precoding weight pattern and stream 2 active pattern.

"Adjust" sets the current sequence length.

When working in "Advanced Mode", it is recommended to adjust the current ARB sequence length to the suggested one.

Remote command:

```
[ :SOURce<hw> ] :BB:W3GPp:SLENgth on page 262
[ :SOURce<hw> ] :BB:W3GPp:BSTation<st>:CHANnel<ch0>:HSDPa:HSET:
SLENgth? on page 307
```

### Adjust

Sets the current ARB sequence length to the suggested value.

When working in "Advanced Mode", it is recommended to adjust the current ARB sequence length to the suggested one.

Remote command:

```
[ :SOURce<hw> ] :BB:W3GPP:BSTation<st>:CHANnel<ch0>:HSDPa:HSET:
SLENgth:ADJust on page 307
```

### Nominal Average Information Bit Rate

Indicates the average data rate on the transport layer. In case of MIMO, the parameter indicates the combined nominal average information bit rate.

The "Nominal Average Information Bit Rate" is calculated for the ideal case of infinite sequence and with regard of the stream 2 active pattern.

Remote command:

```
[ :SOURce<hw> ] :BB:W3GPP:BSTation<st>:CHANnel<ch0>:HSDPa:HSET:
NAIBitrate? on page 303
```

### UE Category

Displays the UE category that is minimum required to receive the selected H-Set (see also [Chapter 2.3.18, "UE capabilities"](#), on page 40).

Remote command:

```
[ :SOURce<hw> ] :BB:W3GPP:BSTation<st>:CHANnel<ch0>:HSDPa:HSET:
UECategory? on page 311
```

### HS-SCCH Type

Sets the HS-SCCH type.

"Type 1 (normal)"      Normal operation mode.

"Type 2 (HS-SCCH less)"      Option: R&S SMBVB-K83  
HS-SCCH less operation mode (see also [Chapter 2.3.12, "HS-SCCH less operation"](#), on page 27).

"Type 3  
(MIMO)"

Option: R&S SMBVB-K83 and enabled two-antenna system. HS-SCCH Type 3 mode is defined for MIMO operation (see also [Chapter 2.3.14.2, "MIMO downlink control channel support"](#), on page 32).

Enabling this operation mode, enables the parameters in section "MIMO Settings" and the stream 2 parameters in sections "HARQ Simulation, Signal Structure" and "Coding Configuration".

While working in HS-SCCH Type 3 mode and simulating Antenna 2 of one two-antenna system without transmit diversity, no control channel is sent. However, the HS-SCCH is displayed as an active in the channel table. To prove, that there is no control channel transmission, consult the "Code Domain Graph".

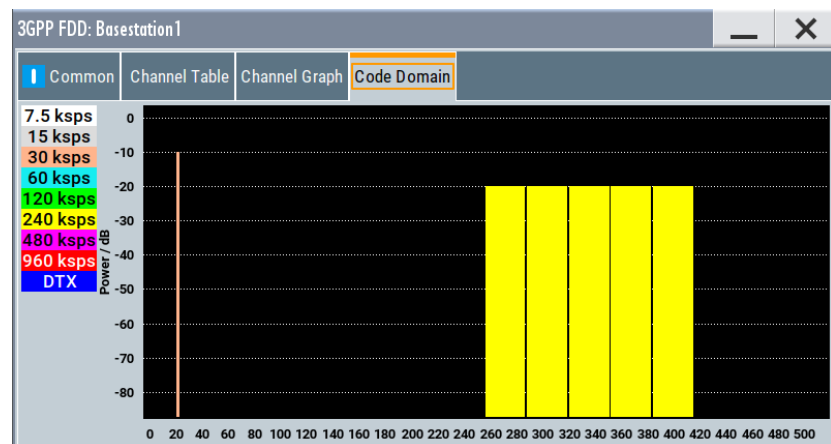

The HS-SCCH channel is displayed as DTX.

Remote command:

```
[ :SOURce<hw> ] :BB:W3Gpp:BSStation<st>:CHANnel<ch0>:HSDPa:HSET:TYPE
```

on page 311

### 3.13.3 MIMO settings



Option: R&S SMBVB-K83, BS1, HSDPA H-Set Mode, and for HS-SCCH Type 3 (MIMO).

Access:

1. Select "3GPP FDD > Link Direction > Downlink".
2. Select "3GPP FDD > Base Stations > Select Base Station > BS1".
3. In the "Common" tab, select "Diversity/MIMO > Antenna 1 of 2".
4. In the "Base Station 1" dialog, select "Channel Table > Preset to HSDPA H-Set".
5. In the "Channel Table" tab, select "Channel#12 HS-SCCH > Enhanced Settings > Config...".



6. In the "BS1/Enhanced HSDPA Mode" dialog, select "Common > Predefined H-Set > H-Set 9/H-Set 11".
7. Select "MIMO Settings".

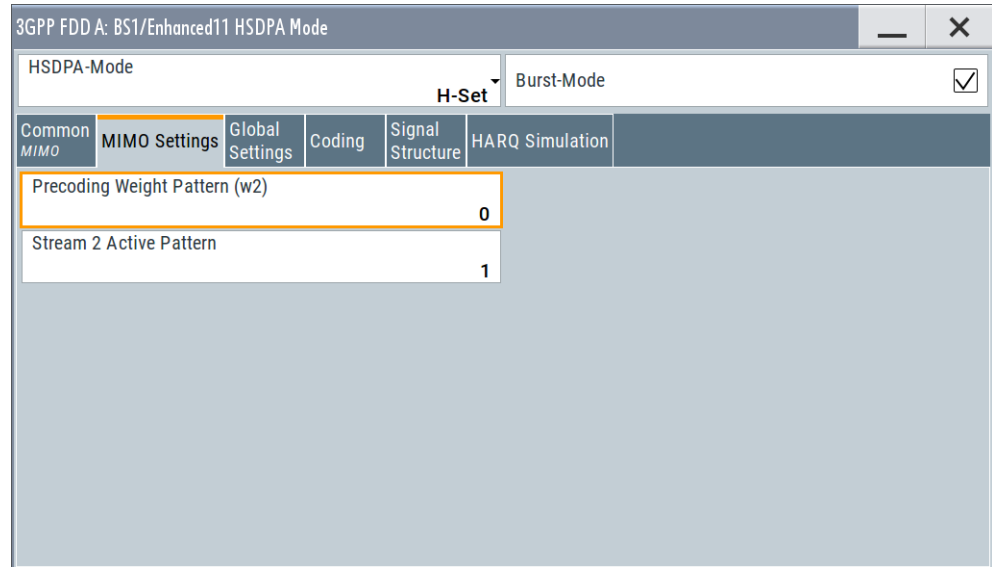

The dialog contains the parameters for configuring the MIMO settings in enhanced HSDPA mode.

#### Precoding Weight Pattern (w2)

Selects the sequence for the MIMO precoding weight parameter w2.

The values of the weight parameters w1, w3 and w4 are calculated based on the value for w2 (see [Chapter 2.3.14, "MIMO in HSPA+", on page 30](#)).

Remote command:

```
[ :SOURCE<hw> ] :BB:W3GPP:BSTation<st>:CHANNEL<ch0>:HSDPa:HSET:
PWPattern on page 304
```

#### Stream 2 Active Pattern

Enables/disables a temporal deactivation of stream 2 per TTI in form of sending pattern.

The stream 2 sending pattern is a sequence of max 16 values of "1" (enables stream 2 for that TTI) and "-" (disabled stream 2 for that TTI).

Remote command:

```
[ :SOURCE<hw> ] :BB:W3GPP:BSTation<st>:CHANNEL<ch0>:HSDPa:HSET:
STAPattern on page 308
```

### 3.13.4 Global settings



The parameters in this section are available for BS1 and HSDPA H-Set Mode only.

3GPP FDD: BS1/Enhanced12 HSDPA Mode						
HSDPA-Mode			Burst-Mode <input checked="" type="checkbox"/>			
Common <i>MIMO</i>	MIMO Settings	Global Settings	Coding	Signal Structure	HARQ Simulation	
Data Source (HS-DSCH)			PN 9			
UEID (H-RNTI)			0			
Channelization Code HS-SCCH (SF128)			5			
Number Of HS-PDSCH Channelization Codes			15		Start Channelization Code HS-PDSCH (SF16) 1	
Total HS-PDSCH Power			-8.24 dB			

### Data Source (HS-DSCH)

Selects the data source for the transport channel.

New data is retrieved from the data source each time an initial transmission is performed within one TTI. An initial transmission is performed in case of "HARQ Mode > Constant ACK" or by each new beginning of the "Redundancy Version Sequence".

The following standard data sources are available:

- "All 0, All 1"  
An internally generated sequence containing 0 data or 1 data.
- "PNxx"  
An internally generated pseudo-random noise sequence.
- "Pattern"  
An internally generated sequence according to a bit pattern.  
Use the "Pattern" box to define the bit pattern.
- "Data List/Select DList"  
A binary data from a data list, internally or externally generated.  
Select "Select DList" to access the standard "Select List" dialog.
  - Select the "Select Data List > navigate to the list file \*.dm\_iqd > Select" to select an existing data list.
  - Use the "New" and "Edit" functions to create internally new data list or to edit an existing one.
  - Use the standard "File Manager" function to transfer external data lists to the instrument.

See also:

- Section "Modulation Data" in the R&S SMBV100B user manual.
- Section "File and Data Management" in the R&S SMBV100B user manual.
- Section "Data List Editor" in the R&S SMBV100B user manual

Remote command:

`[ :SOURce<hw> ] :BB:W3GPP:BSTation<st>:CHANnel<ch0>:HSDPa:HSET:DATA`  
on page 300

`[ :SOURce<hw> ] :BB:W3GPP:BSTation<st>:CHANnel<ch0>:HSDPa:HSET:`  
`DATA:PATtern` on page 301

`[ :SOURce<hw> ] :BB:W3GPP:BSTation<st>:CHANnel<ch0>:HSDPa:HSET:`  
`DATA:DSElect` on page 300

### UEID (H-RNTI)

Enters the UE identity which is the HS-DSCH Radio Network Identifier (H-RNTI) defined in 3GPP TS 25.331: "Radio Resource Control (RRC); Protocol Specification".

Remote command:

`[ :SOURce<hw> ] :BB:W3GPP:BSTation<st>:CHANnel<ch0>:HSDPa:HSET:UEID`  
on page 312

### Channelization Code HS-SCCH (SF128)

Sets the channelization code of the HS-SCCH.

Remote command:

`[ :SOURce<hw> ] :BB:W3GPP:BSTation<st>:CHANnel<ch0>:HSDPa:HSET:`  
`HSCCode` on page 302

### Number of HS-PDSCH Channelization Codes

Sets the number of physical HS-PDSCH data channels assigned to the HS-SCCH.

The maximum number of channels assigned to the H-Set depends on the "HS-SCCH Type" and the channel number of the first HS-PDSCH channel in the H-Set.

For HS-SCCH Type 2 (less operation), maximum of two channels can be assigned.

For HS-SCCH Type 1 (normal operation) and Type 3 (MIMO), the maximum number of assigned channels is 15.

Remote command:

`[ :SOURce<hw> ] :BB:W3GPP:BSTation<st>:CHANnel<ch0>:HSDPa:HSET:`  
`CLENgth` on page 299

### Start Channelization Code HS-PDSCH (SF16)

Sets the channelization code of the first HS-PDSCH channel in the H-Set.

The channelization codes of the rest of the HS-PDSCHs in the H-Set are set automatically.

Remote command:

`[ :SOURce<hw> ] :BB:W3GPP:BSTation<st>:CHANnel<ch0>:HSDPa:HSET:`  
`SCCode` on page 307

### Total HS-PDSCH Power

Sets the total HS-PDSCH power, i.e. sets the total power of all HS-PDSCH channels in the H-Set.

**Note:** In the 3GPP test specification, e.g. 3GPP TS34.121-1, the HS-PDSCH power is typically given as total power of all HS-PDSCH channels.

Use this parameter to set the HS-PDSCH power level directly as given in the 3GPP test specification.

There are two possibilities to set the power of an H-Set:

- Select "BS1 > Channel Table > HS-PDSCH Channel > Power" and set the power of the individual channels.  
The total power of all HS-PDSCH channels of the H-Set depends on the [Number of HS-PDSCH Channelization Codes](#) and is calculated as follows:  
$$TotalPower_{All\ HS-PDSCHs} = Power_{HS-PDSCH\ Channel} + 10 * \log_{10}(NumberOfHS-PDSCHChannelizationCodes)$$
  
The calculated total power is displayed with the parameter "Total HS-PDSCH Power"
- Set directly the total power of the H-Set, i.e set the parameter "Total HS-PDSCH Power"  
The individual power levels of the HS-PDSCHs are calculated automatically and displayed in the "BS1 > Channel Table > HS-PDSCH Channel > Power".

#### Example:

Select "BS1 > HSDPA H-Set".

The default H-Set with five channelization codes ("BS1 > Channel table > HSDPA Settings > Config > Enhanced HSDPA Mode > Number of HS-PDSCH Channelization Codes") is configured.

The default individual power levels of the HS-PDSCH channels are -20 dB. The "Total HS-PDSCH Power" is -13.01 dB.

Set the "Total HS-PDSCH Power" to -10 dB. The individual power levels of the HS-PDSCH channels are -16.99 dB.

Remote command:

```
[ :SOURCE<hw> ] :BB:W3GPP:BSStation<st>:CHANNEL<ch0>:HSDPA:HSET:
TPOWER on page 309
```

### 3.13.5 Coding configuration



Option: R&S SMBVB-K83 for stream 2 and "HS-SCCH Type 3"; other settings BS1 and "HSDPA H-Set Mode".

To access the dialog for the two streams case:

1. Select "3GPP FDD > Link Direction > Downlink".
2. Select "3GPP FDD > Base Stations > Select Base Station > BS1".
3. In the "Base Station 1" dialog, select "Channel Table > Preset to HSDPA H-Set".
4. In the "Common" tab, select "Diversity/MIMO > Antenna 1 of 2".
5. In the "Channel Table" tab, select "Channel#12 HS-SCCH > Enhanced Settings > Config...".

6. In the "BS1/Enhanced HSDPA Mode" dialog, select "Common > HS-SCCH Type > Type 3 (MIMO)".
7. Select "Coding".

Stream 1:		Stream 2:	
HS-PDSCH Modulation	QPSK	HS-PDSCH Modulation	QPSK
Binary Channel Bits Per TTI (Physical Layer)	4 800	Binary Channel Bits Per TTI (Physical Layer)	4 800
Transport Block Size Table	Table 0	Transport Block Size Table	Table 0
Transport Block Size Index	41	Transport Block Size Index	41
Information Bit Payload (TB-Size)	3 202	Information Bit Payload (TB-Size)	3 202
Coding Rate	0.667	Coding Rate	0.667
Virtual IR Buffer Size (per HARQ Process)		Virtual IR Buffer Size (per HARQ Process)	

This dialog contains the parameters required to configure the streams for HSDPA H-Set mode.

#### HS-PDSCH Modulation Stream1/2

Sets the HS-PDSCH modulation for stream 1 and stream 2 to QPSK, 16QAM or 64QAM.

**Note:** Option: R&S SMBVB-K83 for 64QAM.

For HS-SCCH Type 2, the available modulation scheme is QPSK only.

For HS-SCCH Type 3 (MIMO), the modulation selected for stream 1 has to be the higher-order one, i.e. combination 16QAM/64QAM is not allowed.

Remote command:

```
[ :SOURce<hw> ] :BB:W3GPp:BSTation<st>:CHANnel<ch0>:HSDPa:HSET:
MODulation<di> on page 303
```

#### UE Supports 64QAM

(Available for BS1, "HSDPA H-Set Mode", "HS-SCCH Type 1" and "16QAM" only)

Enables/disables UE support of 64QAM.

In case this parameter is disabled, i.e. the UE does not support 64QAM, the 7 bit is used for channelization information.

Remote command:

```
[ :SOURce<hw> ] :BB:W3GPp:BSTation<st>:CHANnel<ch0>:HSDPa:HSET:
S64Qam on page 306
```

#### Binary Channel Bits per TTI (Physical Layer) Stream1/2

Displays the coded binary channel bits per TTI and per stream.

The value displayed is calculated upon the values and selections for the parameters "HS-PDSCH Modulation", "Symbol Rate" and "Number of HS-PDSCH Channel Codes".

Remote command:

```
[ :SOURCE<hw> ] :BB:W3GPP:BSTation<st>:CHANnel<ch0>:HSDPa:HSET:BCBTti<di>? on page 298
```

#### Transport Block Size Table Stream1/2

Selects Table 0 or Table 1 as described in 3GPP TS 25.321.

For "HS-PDSCH Modulation" set to 64QAM, only Table 1 is available.

Remote command:

```
[ :SOURCE<hw> ] :BB:W3GPP:BSTation<st>:CHANnel<ch0>:HSDPa:HSET:TBS:TABLE<di> on page 310
```

#### Transport Block Size Index Stream1/2

Selects the index  $k_i$  for the corresponding table and stream, as described in 3GPP TS 25.321.

Remote command:

```
[ :SOURCE<hw> ] :BB:W3GPP:BSTation<st>:CHANnel<ch0>:HSDPa:HSET:TBS:INDEX<di> on page 309
```

#### Transport Block Size Reference Stream1/2

(Available for BS1, HSDPA H-Set Mode and HS-SCCH Type 2 only)

While working in less operation mode, this parameter is signaled instead of the parameter "Transport Block Size Index".

Remote command:

```
[ :SOURCE<hw> ] :BB:W3GPP:BSTation<st>:CHANnel<ch0>:HSDPa:HSET:TBS:REFERENCE on page 310
```

#### Information Bit Payload (TB-Size) Stream 1/2

Displays the payload of the information bit. This value determines the number of transport layer bits sent in each TTI before coding.

Remote command:

```
[ :SOURCE<hw> ] :BB:W3GPP:BSTation<st>:CHANnel<ch0>:HSDPa:HSET:BPAYload<di>? on page 299
```

#### Coding Rate Stream 1/2

Displays the resulting coding rate per stream.

The coding rate is calculated as a relation between the "Information Bit Payload" and "Binary Channel Bits per TTI".

Remote command:

```
[ :SOURCE<hw> ] :BB:W3GPP:BSTation<st>:CHANnel<ch0>:HSDPa:HSET:CRATE<di>? on page 300
```

#### Virtual IR Buffer Size (per HARQ Process) Stream1/2

Sets the size of the virtual IR buffer (number of SMLs per HARQ process) per stream.

Remote command:

[ :SOURCE<hw> ] :BB:W3GPP:BSTation<st>:CHANnel<ch0>:HSDPa:HSET:  
VIBSize<di> on page 312

### 3.13.6 Signal structure



Option: R&S SMBVB-K83 for stream 2 and "HS-SCCH Type 3"; other settings BS1 and "HSDPA H-Set Mode".

Common <i>MIMO</i>	MIMO Settings	Global Settings	Coding	Signal Structure	HARQ Simulation
HSDPA-Mode					
H-Set					Burst-Mode <input checked="" type="checkbox"/>
Inter TTI Distance				3	
Number Of HARQ Processes Per Stream				2	
Signaling Pattern Stream 1				0,-,1,-	
Signaling Pattern Stream 2				2,-,3,-	

#### Inter TTI Distance (H-Set)

(Available for "subframe x")

Selects the distance between two packets in HSDPA packet mode.

The distance is set in number of sub-frames (3 slots = 2 ms). An "Inter TTI Distance" of 1 means continuous generation.

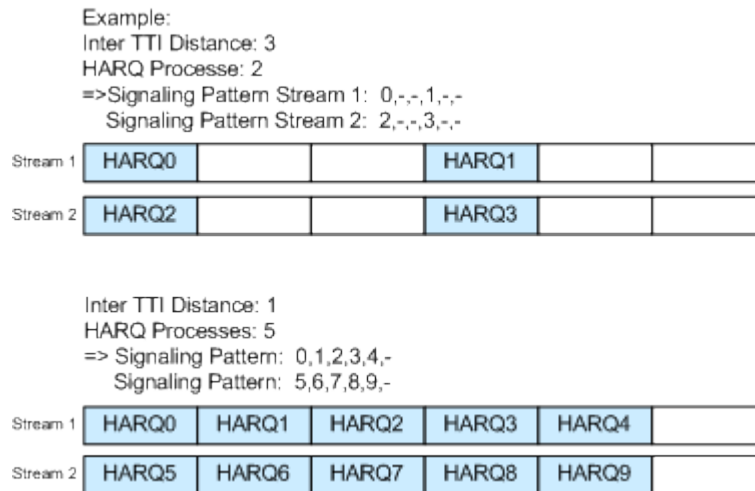

**Figure 3-9: Example: Inter TTI Distance in HSDPA H-Set Mode**

Remote command:

```
[ :SOURCE<hw> ] :BB:W3GPP:BSTation<st>:CHANnel<ch0>:HSDPa:
TTIDistance on page 314
```

#### Number of HARQ Processes per Stream

Sets the number of HARQ processes. This value determines the distribution of the payload in the subframes and depends on the Inter "TTI Distance" (see figure).

A minimum of six HARQ Processes are required to achieve continuous data transmission.

Remote command:

```
[ :SOURCE<hw> ] :BB:W3GPP:BSTation<st>:CHANnel<ch0>:HSDPa:HSET:
HARQ:LENGTH on page 301
```

#### Signaling Pattern Stream1/2

Displays the distribution of packets over time. The "Signaling Pattern" displays a HARQ-Process cycle and is a sequence of HARQ-IDs and "-". An HARQ-ID indicates a packet, a "-" indicates no packet (see figure). The signaling pattern is cyclically repeated.

Long signaling patterns with regular repeating groups of HARQ-ID and "-" are not displayed completely. The signaling pattern is shortened and ". . ." is displayed but the scheduling is performed according to the selected "Inter TTI Distance". Long signaling patterns with irregularity in the HARQ-ID and "-" groups are displayed completely.

Depending on the selected "Burst Mode", a dummy TTI is sent within the no packet subframes.

Remote command:

```
[ :SOURCE<hw> ] :BB:W3GPP:BSTation<st>:CHANnel<ch0>:HSDPa:HSET:
SPATtern<di>? on page 308
```



### 3.13.7 HARQ simulation



Option: R&S SMBVB-K83 for stream 2 and "HS-SCCH Type 3"; other settings BS1 and "HSDPA H-Set Mode".

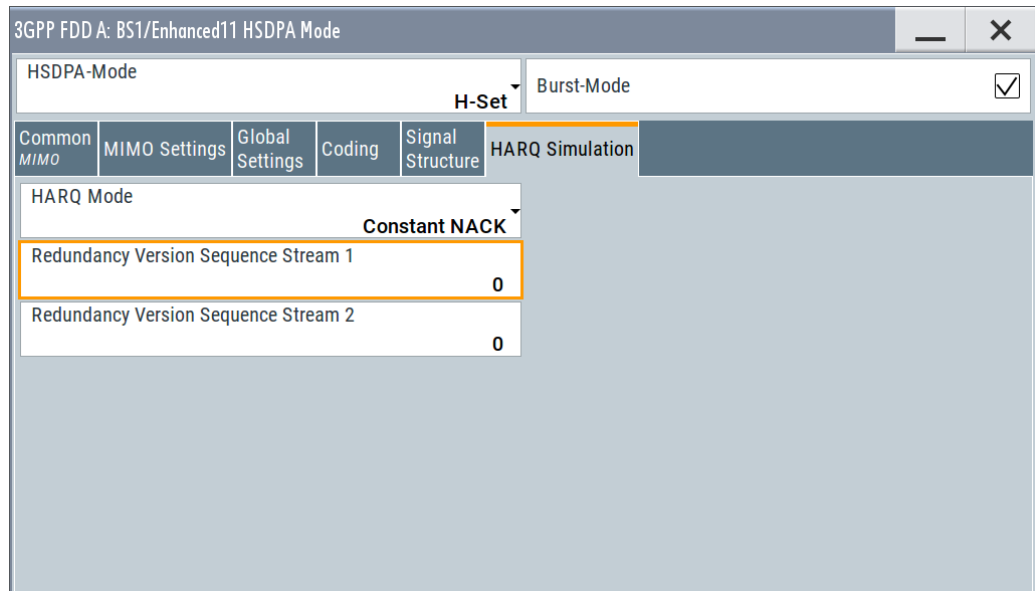

#### Mode (HARQ Simulation)

Sets the HARQ simulation mode.

**Note:** To let the instrument generate a signal equal to the one generated by an instrument equipped with older firmware, set the "HARQ Mode" to "Constant ACK".

"Constant ACK"

New data is used for each new TTI. This mode is used to simulate maximum throughput transmission.

"Constant NACK"

(enabled in "Advanced Mode" only)

Enables NACK simulation, i.e. depending on the sequence selected with parameter "Redundancy Version Parameter Sequence" packets are retransmitted. This mode is used for testing with varying redundancy version.

Remote command:

```
[ :SOURce<hw> ] :BB:W3GpP:BSTation<st>:CHANnel<ch0>:HSDPa:HSET:
HARQ:MODE on page 302
```

#### Redundancy Version Stream1/2

The parameter is enabled for "HARQ Simulation Mode > Constant ACK".

Enters the redundancy version per stream. This value determines the processing of the Forward Error Correction and constellation arrangement (16/64QAM modulation), see TS 25.212 4.6.2.

For HS-SCCH Type 2 (less operation), the redundancy version is always 0.

Remote command:

`[ :SOURCE<hw> ] :BB:W3GPP:BSTation<st>:CHANnel<ch0>:HSDPa:HSET:RVParameter<di>` on page 304

### Redundancy Version Sequence Stream 1/2

The parameter is enabled for "HARQ Simulation Mode > Constant NACK".

Enters a sequence of redundancy version per stream. The value of the RV parameter determines the processing of the Forward Error Correction and constellation arrangement (16/64QAM modulation), see TS 25.212 4.6.2.

The sequence has a length of maximum 30 values. The sequence length determines the maximum number of retransmissions. New data is retrieved from the data source after reaching the end of the sequence.

For HS-SCCH Type 2 (less operation), the redundancy version sequence is always "0, 3, 4".

Remote command:

`[ :SOURCE<hw> ] :BB:W3GPP:BSTation<st>:CHANnel<ch0>:HSDPa:HSET:RVSequence<di>` on page 305

## 3.13.8 Error insertion



The parameters in this section are available for BS1, HSDPA H-Set Mode and disabled Advanced Mode only.

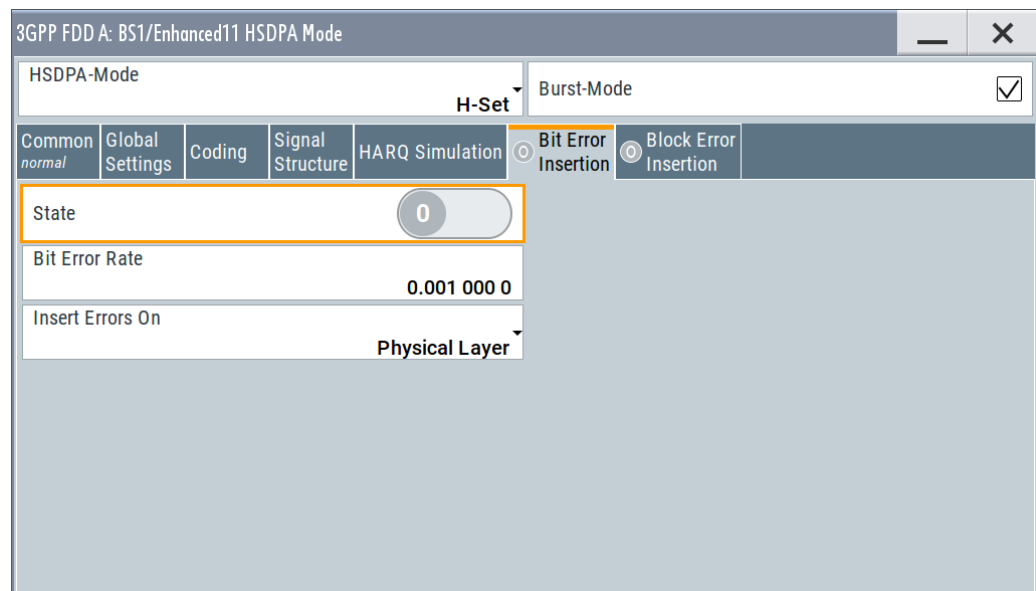

In the "Bit/Block Error Insertion" sections, errors can be inserted into the data source and into the CRC checksum. This can be used for example to test the bit and block error rate testers.

**Bit Error State (HSDPA H-Set)**

Activates or deactivates bit error generation.

Bit errors are inserted into the data stream of the coupled HS-PDSCHs. It is possible to select the layer in which the errors are inserted (physical or transport layer).

When the data source is read out, bits are deliberately inverted at random points in the data bitstream at the specified error rate so that an invalid signal is simulated.

Remote command:

```
[ :SOURCE<hw> ] :BB:W3GPP:BSTation [ :ENHanced ] :CHANnel<ch0>:HSDPa:
DERRor:BIT:STATe on page 349
```

**Bit Error Rate (HSDPA H-Set)**

Sets the bit error rate.

Remote command:

```
[ :SOURCE<hw> ] :BB:W3GPP:BSTation [ :ENHanced ] :CHANnel<ch0>:HSDPa:
DERRor:BIT:RATE on page 349
```

**Insert Errors On (HSDPA H-Set)**

Selects the layer at which bit errors are inserted.

"Transport layer"

Bit errors are inserted in the transport layer.

"Physical layer"

Bit errors are inserted in the physical layer.

Remote command:

```
[ :SOURCE<hw> ] :BB:W3GPP:BSTation [ :ENHanced ] :CHANnel<ch0>:HSDPa:
DERRor:BIT:LAYer on page 348
```

**Block Error State (HSDPA H-Set)**

Activates or deactivates block error generation.

The CRC checksum is determined and then the last bit is inverted at the specified error probability in order to simulate an invalid signal.

Remote command:

```
[ :SOURCE<hw> ] :BB:W3GPP:BSTation [ :ENHanced ] :CHANnel<ch0>:HSDPa:
DERRor:BLOCK:STATe on page 350
```

**Block Error Rate (HSDPA H-Set)**

Sets the block error rate.

Remote command:

```
[ :SOURCE<hw> ] :BB:W3GPP:BSTation [ :ENHanced ] :CHANnel<ch0>:HSDPa:
DERRor:BLOCK:RATE on page 349
```

### 3.13.9 Randomly varying modulation and number of codes (Type 3i) settings

Option: R&S SMBVB-K83, HS-SCCH Type 1 and enabled [Advanced Mode](#).

Access:

1. Select "3GPP FDD > Link Direction > Downlink".
2. Select "3GPP FDD > Base Stations > Select Base Station > BS1".
3. In the "Base Station 1" dialog, select "Channel Table > Preset to HSDPA H-Set".
4. In the "Channel Table" tab, select "Channel#12 HS-SCCH > Enhanced Settings > Config...".
5. In the "BS1/Enhanced HSDPA Mode" dialog, select "Common".
6. Select "Advanced Mode > On".
7. Select "HS-SCCH Type > Type 1 (normal)".
8. Select the "Type 3i" tab.

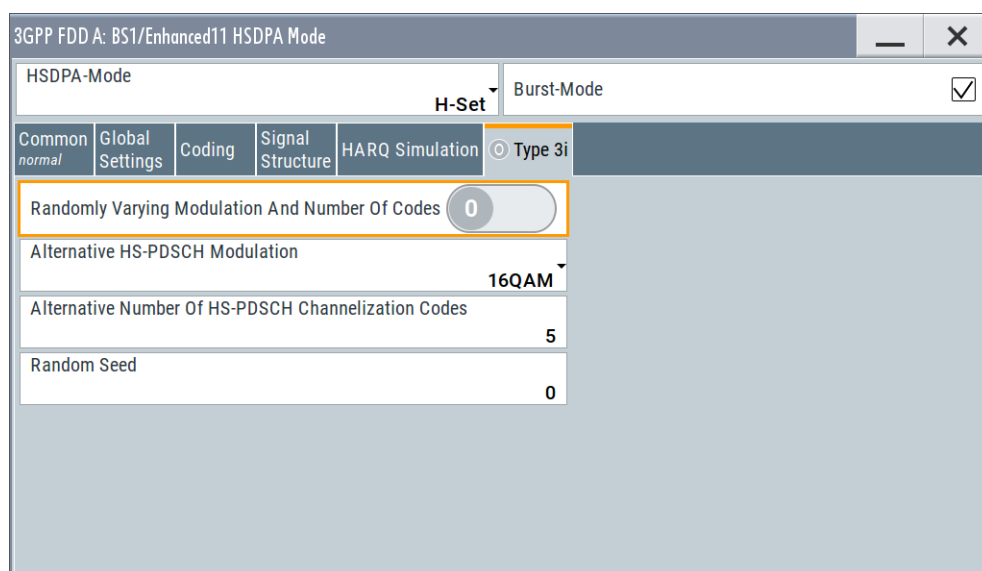

This section comprises the settings necessary to configure the signal of both interferer according to the 3i enhanced performance requirements tests, described in 3GPP TS34.12.-1, chapters 9.2.1L and 9.2.1LA.

The used modulation and number of HS-PDSCH codes in an H-Set is randomly selected every HSDPA TTI among four options with equal probability (see [Table 3-6](#)).

**Table 3-6: Used modulation and number of HS-PDSCH codes**

Option	Modulation	Number of HS-PDSCH codes
1	HS-PDSCH Modulation	Alternative Number of HS-PDSCH Channelization Codes
2	"Alternative HS-PDSCH Modulation" on page 109	Alternative Number of HS-PDSCH Channelization Codes
3	HS-PDSCH Modulation	Number of HS-PDSCH Channelization Codes
4	"Alternative HS-PDSCH Modulation" on page 109	Number of HS-PDSCH Channelization Codes



Although the number of active HS-PDSCH channels varies over time, the overall power of the HS-PDSCH channels in the H-Set stays constant. This is because the power of the individual HS-PDSCH channels is raised when the number is reduced. The channel powers displayed in the "BS > Channel Table" are the channel powers during the TTIs in which the [Number of HS-PDSCH Channelization Codes](#) is applied.

The ARB sequence length suggestion does not consider the statistical process of the selection among the four options. It can be necessary that you further increase the ARB sequence length to achieve the desired statistical properties.

See [ARB Seq Length](#).



To generate a signal without unwanted artifacts, select "3GPP FDD > Filter/Clipping/ARB Settings" and set the parameter [Sequence Length ARB](#) to a multiple of the suggested length.

The configured transport block size table and transport block size index are used in all TTIs, no matter which of the four options is used. The payload size can vary over time and can deviate from the value displayed with the parameter [Information Bit Payload \(TB-Size\) Stream 1/2](#).

#### Randomly Varying Modulation And Number Of Codes

Enables/disables the random variation of the modulation and codes.

Remote command:

```
[ :SOURCE<hw> ] :BB:W3GPp:BSTation<st>:CHANnel<ch0>:HSDPa:HSET:RVState on page 305
```

#### Alternative HS-PDSCH Modulation

Sets the alternative modulation (see [Table 3-6](#)).

Remote command:

```
[ :SOURCE<hw> ] :BB:W3GPp:BSTation<st>:CHANnel<ch0>:HSDPa:HSET:ALTModulation on page 298
```

#### Alternative Number of HS-PDSCH Channelization Codes

Sets the alternative number of HS-PDSCH channelization codes (see [Table 3-6](#)).

Remote command:

```
[ :SOURCE<hw> ] :BB:W3GPp:BSTation<st>:CHANnel<ch0>:HSDPa:HSET:ACLlength on page 298
```

#### Random Seed

Sets the seed for the random process deciding between the four options (see [Table 3-6](#)).

Remote command:

```
[ :SOURCE<hw> ] :BB:W3GPp:BSTation<st>:CHANnel<ch0>:HSDPa:HSET:SEED on page 306
```

## 3.14 Enhanced settings for P-CPICH - BS1

Access:

- ▶ Select "3GPP FDD > BS > Channel Table > P-CPICH > Enhanced Settings > Config".

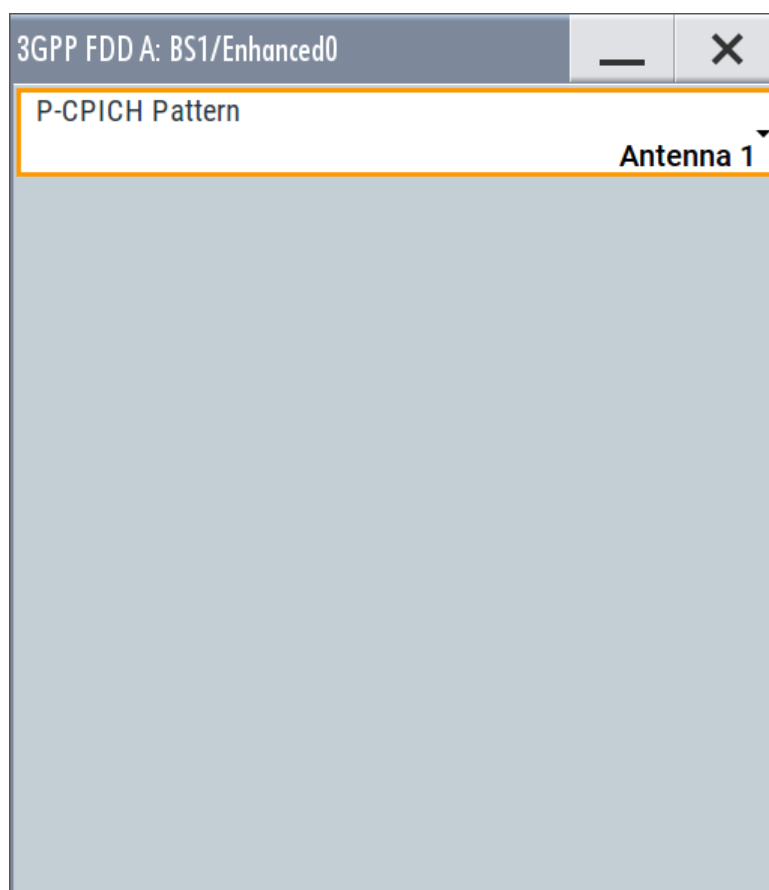

### **P-CPICH Pattern**

Sets the P-CPICH pattern (channel 0).

Remote command:

```
[ :SOURCE<hw> ] :BB:W3Gp:BSTation<st>:ENHanced:PCPich:PATtern
```

on page 330

## 3.15 Enhanced settings for P-CCPCH - BS1

Access:

- ▶ Select "3GPP FDD > BS1 > Channel Table > P-CCPCH > Enhanced Settings > Config".

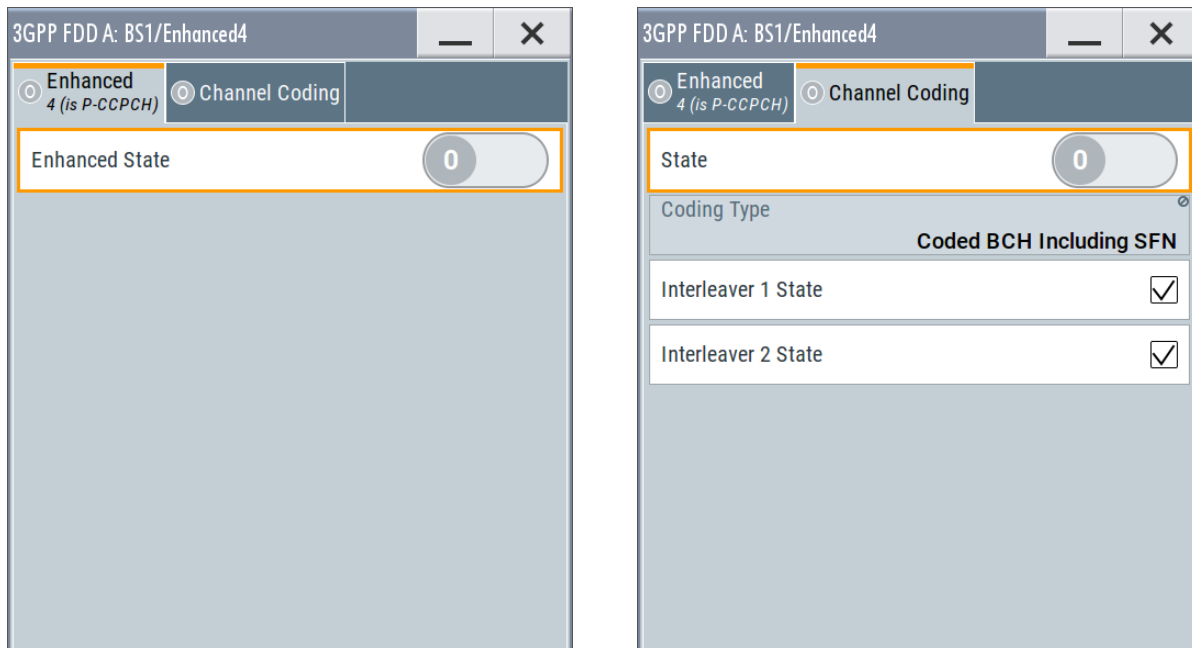

The dialog comprises the settings for configuring the enhanced state of this displayed channel and the channel coding settings. Interleaver states 1 and 2 can be activated separately.

The settings for the enhanced P-CCPCH channel and the enhanced DPCH channels are different (see [Chapter 3.16, "Enhanced settings for DPCHs - BS1"](#), on page 113).

### 3.15.1 Channel number and state

#### Channel Number (Enhanced P-CCPCH)

Displays the channel number and the channel type.

Remote command:

n.a.

#### State (Enhanced P-CCPCH)

Switches the P-CCPCH (Primary Common Control Phys. Channel) to the enhanced state. The channel signal is generated in real time.

Remote command:

[ :SOURce<hw> ] :BB:W3GPP:BSTation:ENHanced:PCCPch:STATe on page 330

### 3.15.2 Channel coding - enhanced P-CCPCH BS1

The "Channel Coding" section is where the channel coding settings are made.

The channel-coded P-CCPCH (Broadcast Channel BCH) with System Frame Number is generated according to the following principle.

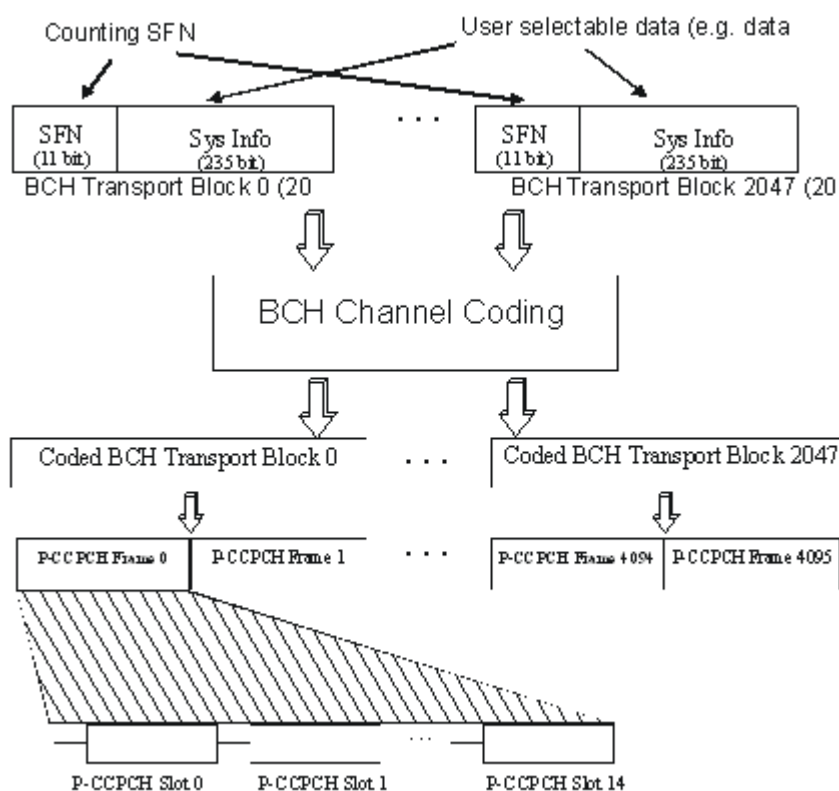

Figure 3-10: Generation of a channel coded P-CCPCH/BCH

The data blocks of the BCH at transport-channel level comprise data determined for 20 ms of the P-CCPCH (i.e. 2 frames) after channel coding. The first field of such a data block is an 11-bit long field for the system frame number (SFN). The SFN is automatically incremented by 1 (as stipulated in the standard) from transport block to transport block. This is equivalent to a step width of 2 frames due to the transport time interval length of 20 ms. After 2048 transport blocks (equivalent to 4096 frames), the SFN is reset and starts again at 0 (SFN restart). An output trigger indicating the SFN restart can be generated.

The SFN format is defined in the standard; it is MSB-first coded.

The remaining system information (a 235-bit long field per block) is filled from the data source selected for the P-CCPCH.



A data list can be used to transmit further specific system information in addition to the SFN. If only the SFN is required, "ALL 0" is recommended as data source for P-CCPCH.

The BCH transport blocks are then channel-coded. A coded transport block comprises the data sequence for two P-CCPCH frames.

#### Channel Coding State

Activates or deactivates channel coding.

The coding scheme is displayed in the field below.

Remote command:

```
[ :SOURCE<hw> ] :BB:W3GPp:BSTation:ENHanced:PCCPch:CCODing:STATe  
on page 342
```

#### Channel Coding Type

Displays the coding scheme.

The coding scheme of P-CCPCH (BCH) is specified in the standard. The channel is generated automatically with the counting system frame number (SFN). The system information after the SFN field is completed from the selected data source.

Remote command:

```
[ :SOURCE<hw> ] :BB:W3GPp:BSTation:ENHanced:PCCPch:CCODing:TYPE?  
on page 342
```

#### Interleaver

Activates or deactivates channel coding interleaver states 1 and 2.

**Note:** The interleaver states do not cause the symbol rate to change

Remote command:

```
[ :SOURCE<hw> ] :BB:W3GPp:BSTation:ENHanced:PCCPch:CCODing:  
INTerleaver<di> on page 342
```

## 3.16 Enhanced settings for DPCHs - BS1

The settings for the enhanced P-CCPCH channel (see [Chapter 3.15, "Enhanced settings for P-CCPCH - BS1"](#), on page 111) and the enhanced DPCH channels are different. This section describes the settings for the enhanced DPCH channels (channels#11 to 13). The channels can be configured independently.



Use the [HSDPA settings - BS](#) dialog to configure the high-speed channels.

### 3.16.1 Channel number and state

Access:

- ▶ Select "3GPP FDD > BS1 > Channel Table > Channel#11 to 13 > DPCH > Enhanced/HSDPA Settings > Config... > Enhanced".

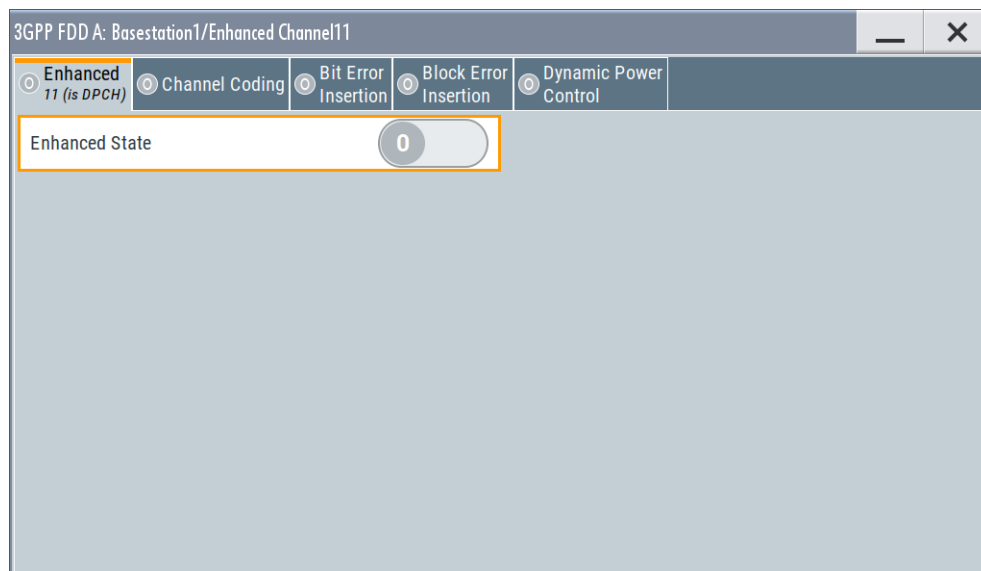

In this tab, you can activate the currently selected channel.

#### Enhanced State

Switches the DPCH channel to the enhanced state.

In the enhanced state, the modulation signal of the selected channel is generated in real time. It is possible to activate channel coding and simulate bit and block errors or use dynamic power control. Data lists, for example with user data for the transport layer, can be used as the data source.

Remote command:

```
[ :SOURce<hw> ] :BB:W3GpP:BSTation:ENHanced:CHANnel<ch0>:DPCH:STATE  
on page 330
```

### 3.16.2 Channel coding

Access:

- ▶ Select "3GPP FDD > BS1 > Channel Table > Channel#11 to 13 > DPCH > Enhanced/HSDPA Settings > Config... > Channel Coding".

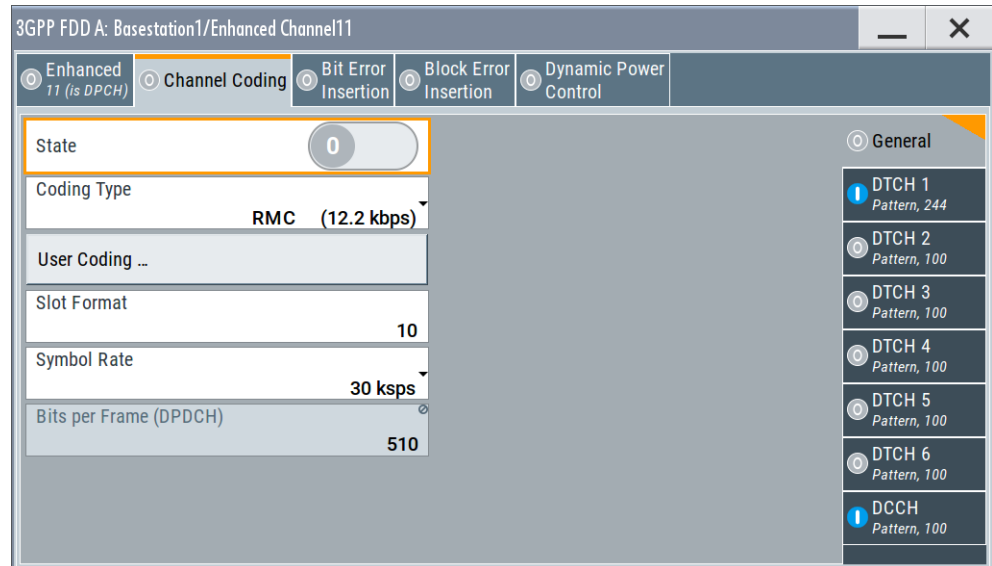

The "Channel Coding > General" tab comprises the settings for enabling and configuring the channel coding. The provided settings are divided into general settings and several subtabs, one per transport channel.

To access the channel coding settings of a transport channel, select the corresponding side tab, for example "DTCH1". Refer to [Chapter 3.16.3, "Transport channel - enhanced DPCHs BS1"](#), on page 118 for description of the provided settings.

According to 3GPP TS 25.101, a downlink reference measurement channel is generated when the transport channels DTCH and DCCH are mapped to a DPCH with a different data rate after channel coding and multiplexing. The figure below is taken from the standard (TS 25.101). It illustrates the generation of a 12.2 kbps reference measurement channel from the DTCH and DCCH transport channels (see standard for figures and tables of other reference measurement channels).

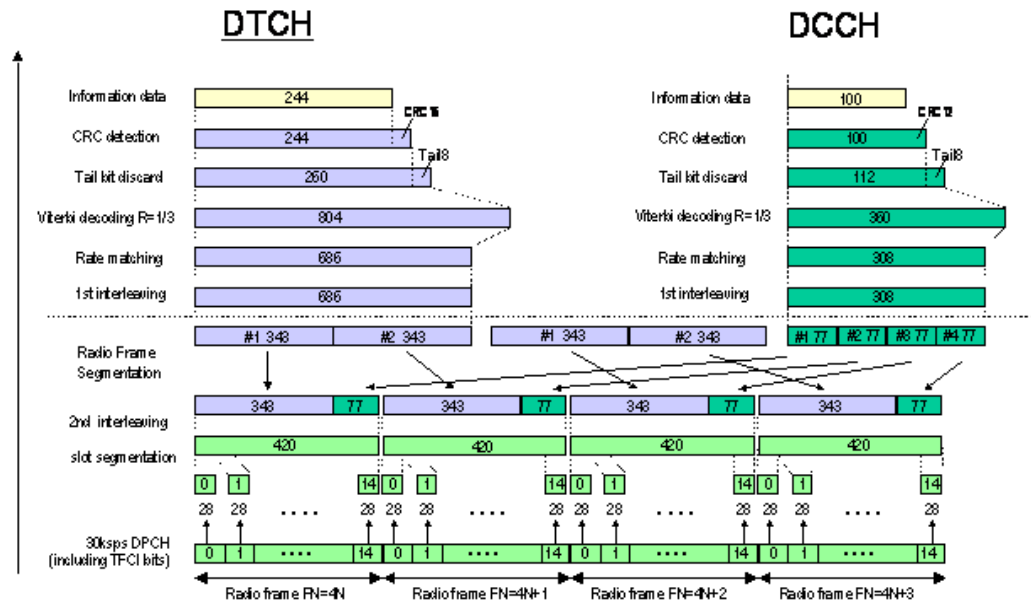

Figure 3-11: Channel coding of the 12.2 kbps reference measurement channel (downlink)

The Table 3-7 shows a summary of the transport channel parameters of the 12.2 kbps reference measurement channel

Table 3-7: Transport channel parameters (12.2 kbps reference measurement channel)

Parameter	DCCH	DTCH
Data Source	All 0	All 0
Transport Block Size	100	244
Transmission Time Interval	40 ms	20 ms
Type of Error Protection	Convolution Coding	Convolution Coding
Coding Rate	1/3	1/3
Rate Matching attribute	256	256
Size of CRC	12	16
Interleaver 1/2	On	On

### Channel Coding State

Activates or deactivates channel coding.

Channel-coded measurement channels - so-called "reference measurement channels" - are required for many test procedures specified by the standard.

When channel coding is activated, the slot format, the symbol rate, the pilot length and the TFCI state are predetermined. The corresponding parameters in the channel table are disabled.

Remote command:

`[ :SOURCE<hw> ] :BB:W3Gpp:BSTation:ENHanced:CHANnel<ch0>:DPCH:CCoding:STATE` on page 334

**Channel Coding Type**

Selects channel coding.

The 3GPP specification defines 4 reference measurement channel coding types, which differ in the input data bit rate bit to be processed (12.2, 64, 144 and 384 kbps). The additional AMR CODER coding scheme generates the coding of a voice channel.

The BTFD coding types with different data rates are also defined in the 3GPP specification (TS 34.121). They are used for the receiver quality test Blind Transport Format Detection. DTX (discontinuous transmission) bits are included in the data stream between rate matching and interleaving 1.

User coding can be defined as required in the detailed coding settings menu section revealed with button "Show Details". They can be stored and loaded in the "User Coding" submenu. Selection User is indicated as soon as a coding parameter is modified after selecting a predefined coding type.

The input data bits are taken for channel coding from the data source specified in the "Transport Channel" dialog section. The bits are available with a higher rate at the channel coding output. The allocations between the measurement input data bit rate and the output symbol rate are fixed, that is to say, the symbol rate is adjusted automatically.

The following are available for selection:

"RMC 12.2 kbps"	12.2 kbps measurement channel
"RMC 64 kbps"	64 kbps measurement channel
"RMC 144 kbps"	144 kbps measurement channel
"RMC 384 kbps"	384 kbps measurement channel
"AMR 12.2 kbps"	Channel coding for the AMR coder
"BTFD Rate 1 12.2ksp/s"	Blind Transport Format Detection Rate 1 (12.2 kbps)
"BTFD Rate 2 7.95ksp/s"	Blind Transport Format Detection Rate 2 (7.95 kbps)
"BTFD Rate 3 1.95ksp/s"	Blind Transport Format Detection Rate 3 (1.95 kbps)

Remote command:

```
[ :SOURce<hw> ] :BB:W3GPp:BSTation:ENHanced:CHANnel<ch0>:DPCH:CCODing:TYPE on page 334
```

**User Coding**

Accesses the standard "File Select" function of the instrument. The provided navigation possibilities in the dialog are self-explanatory.

See also, chapter "File and Data Management" in the R&S SMBV100B User Manual.

Files with user coding are files with the predefined file extension \*.3g\_ccod\_d1. The filename and the directory they are stored in are user-definable; the file extension is assigned automatically.

The complete channel coding settings are saved and recalled.

Remote command:

```
[ :SOURce<hw> ] :BB:W3GPP:BSTation:ENHanced:CHANnel [<ch0>] :DPCH:
CCODing:USER:CATalog? on page 335
```

```
[ :SOURce<hw> ] :BB:W3GPP:BSTation:ENHanced:CHANnel<ch0>:DPCH:
CCODing:USER:STORE on page 336
```

```
[ :SOURce<hw> ] :BB:W3GPP:BSTation:ENHanced:CHANnel<ch0>:DPCH:
CCODing:USER:LOAD on page 336
```

#### Slot Format (DPDCH)

Enters the slot format. The slot format (and thus the symbol rate, the pilot length and the TFCI state) depends on the coding type selected.

Remote command:

```
[ :SOURce<hw> ] :BB:W3GPP:BSTation:ENHanced:CHANnel<ch0>:DPCH:
CCODing:SFORmat on page 333
```

#### Symbol Rate (DPDCH)

Displays the symbol rate.

The symbol rate is determined by the slot format set.

Remote command:

```
[ :SOURce<hw> ] :BB:W3GPP:BSTation:ENHanced:CHANnel<ch0>:DPCH:
CCODing:SRATE? on page 333
```

#### Bits per Frame (DPDCH)

Displays the data bits in the DPDCH component of the DPCH frame at physical level. The value depends on the slot format.

Remote command:

```
[ :SOURce<hw> ] :BB:W3GPP:BSTation:ENHanced:CHANnel<ch0>:DPCH:
CCODing:BPFRame? on page 332
```

### 3.16.3 Transport channel - enhanced DPCHs BS1

Access:

1. Select "3GPP FDD > BS1 > Channel Table > Channel#11 to 13 > DPCH > Enhanced/HSDPA Settings > Config... > Channel Coding".

- To access the channel coding settings of a transport channel, select the corresponding side tab, for example "DTCH1".

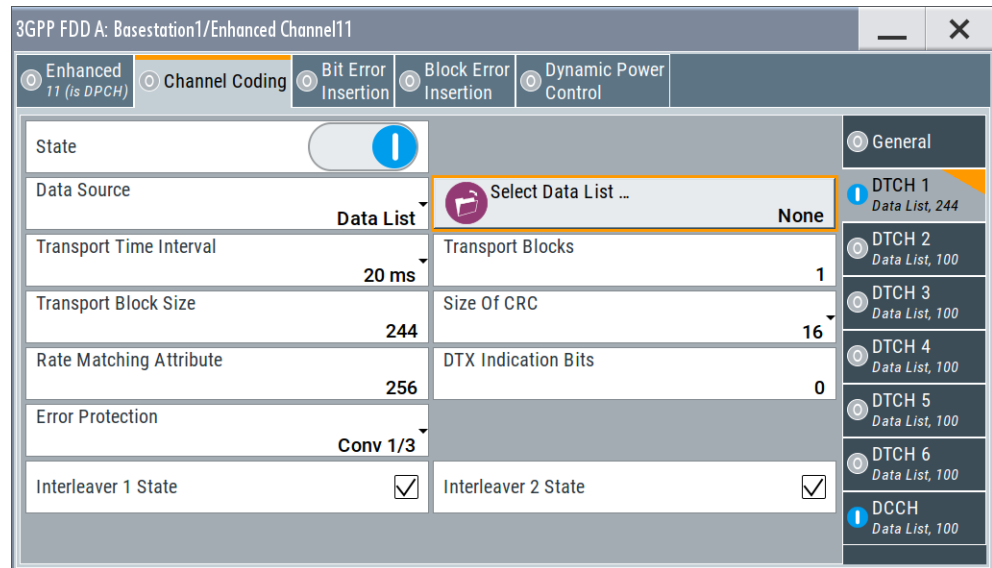

The dialog provides access to the settings of up to seven transport channels (TCHs), the DTCHs (DTCH1 to 6) and the DCCH.

### Transport Channel State

Activates or deactivates the transport channel.

Remote command:

```
[ :SOURce<hw> ] :BB:W3GPp:BSTation:ENHanced:CHANnel<ch0>:DPCH:
TChannel<di0>:STATe on page 341
```

In case of remote control, DCCH corresponds to :TChannel0, DTCH1 to :TChannel1, etc.

### Data Source

Selects the data source for the transport channel.

The following standard data sources are available:

- "All 0, All 1"  
An internally generated sequence containing 0 data or 1 data.
- "PNxx"  
An internally generated pseudo-random noise sequence.
- "Pattern"  
An internally generated sequence according to a bit pattern.  
Use the "Pattern" box to define the bit pattern.
- "Data List/Select DList"  
A binary data from a data list, internally or externally generated.  
Select "Select DList" to access the standard "Select List" dialog.
  - Select the "Select Data List > navigate to the list file \*.dm\_iqd > Select" to select an existing data list.
  - Use the "New" and "Edit" functions to create internally new data list or to edit an existing one.

- Use the standard "File Manager" function to transfer external data lists to the instrument.

See also:

- Section "Modulation Data" in the R&S SMBV100B user manual.
- Section "File and Data Management" in the R&S SMBV100B user manual.
- Section "Data List Editor" in the R&S SMBV100B user manual

Remote command:

`[ :SOURce<hw> ] :BB:W3GPp:BSTation:ENHanced:CHANnel<ch0>:DPCH: TCHannel<di0>:DATA` on page 338

`[ :SOURce<hw> ] :BB:W3GPp:BSTation:ENHanced:CHANnel<ch0>:DPCH: TCHannel<di0>:DATA:PATtern` on page 339

`[ :SOURce<hw> ] :BB:W3GPp:BSTation:ENHanced:CHANnel<ch0>:DPCH: TCHannel<di0>:DATA:DSElect` on page 338

### Transport Time Interval

Sets the number of frames into which a TCH is divided. This setting also defines the interleaver depth.

Remote command:

`[ :SOURce<hw> ] :BB:W3GPp:BSTation:ENHanced:CHANnel<ch0>:DPCH: TCHannel<di0>:TTInterval` on page 342

### Transport Block

Sets the number of transport blocks for the TCH.

Remote command:

`[ :SOURce<hw> ] :BB:W3GPp:BSTation:ENHanced:CHANnel<ch0>:DPCH: TCHannel<di0>:TBCount` on page 341

### Transport Block Size

Sets the size of the transport block at the channel coding input.

Remote command:

`[ :SOURce<hw> ] :BB:W3GPp:BSTation:ENHanced:CHANnel<ch0>:DPCH: TCHannel<di0>:TBSize` on page 341

### Size of CRC

Defines the type (length) of the CRC. Checksum determination can also be deactivated (setting "None").

Remote command:

`[ :SOURce<hw> ] :BB:W3GPp:BSTation:ENHanced:CHANnel<ch0>:DPCH: TCHannel<di0>:CRCSize` on page 337

### Rate Matching Attribute

Sets data rate matching.

Remote command:

`[ :SOURce<hw> ] :BB:W3GPp:BSTation:ENHanced:CHANnel<ch0>:DPCH: TCHannel<di0>:RMAttribute` on page 340



**DTX Indication Bits**

Sets the number of DTX (discontinuous transmission) bits. These bits are entered in the data stream between rate matching and interleaver 1. Channel coding of BTFD reference measurement channels Rate 2 and Rate 3 includes DTX267 and DTX644, respectively (see 3GPP TS 34.121).

Remote command:

```
[ :SOURCE<hw> ] :BB:W3GPP:BSTation:ENHanced:CHANnel<ch0>:DPCH:
TCHannel<di0>:DTX on page 339
```

**Error Protection**

Selects error protection.

"None"	No error protection
"Turbo 1/3"	Turbo coder of rate 1/3 in accordance with the 3GPP specifications.
"Conv 1/2   1/3"	Convolution coder of rate 1/2 or 1/3 with generator polynomials defined by 3GPP.

Remote command:

```
[ :SOURCE<hw> ] :BB:W3GPP:BSTation:ENHanced:CHANnel<ch0>:DPCH:
TCHannel<di0>:EPRotectiion on page 340
```

**Interleaver 1 State**

Activates or deactivates channel coding interleaver state 1 of the transport channel. Interleaver state 1 can be set independently in each TCH. Activation does not change the symbol rate.

Remote command:

```
[ :SOURCE<hw> ] :BB:W3GPP:BSTation:ENHanced:CHANnel<ch0>:DPCH:
TCHannel<di0>:INTerleaver on page 340
```

**Interleaver 2 State**

Activates or deactivates channel coding interleaver state 2 of all the transport channels. Interleaver state 2 can only be set for all the TCHs together. Activation does not change the symbol rate.

Remote command:

```
[ :SOURCE<hw> ] :BB:W3GPP:BSTation:ENHanced:CHANnel<ch0>:DPCH:
INTerleaver2 on page 337
```

**3.16.4 Error insertion - enhanced DPCHs BS1**

Access:

1. Select "3GPP FDD > BS1 > Channel Table > Channel#11 to 13 > Enhanced/HSDPA Settings > Config...".
2. In the "Base Station /Enhanced Channel" dialog, select one of the following:

- a) Select "Bit Error Insertion".

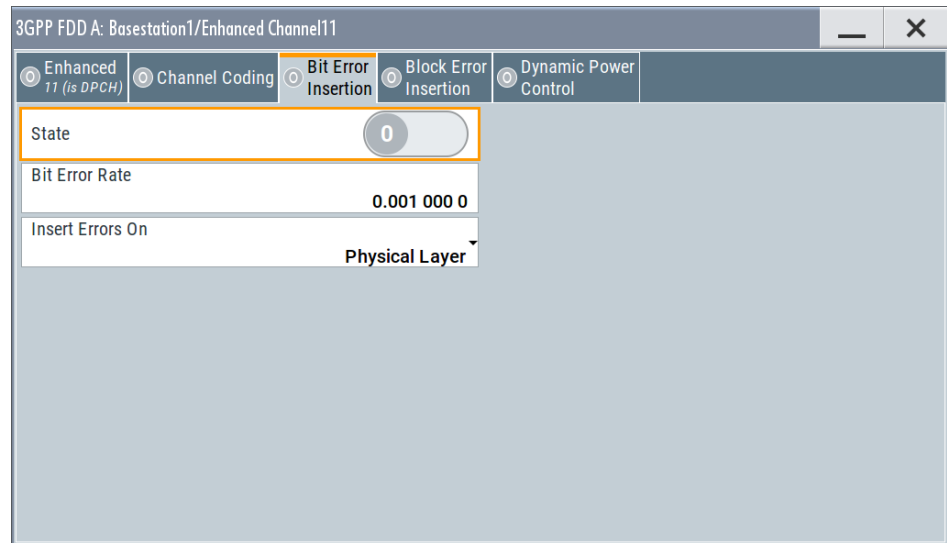

- b) Select "Block Error Insertion".

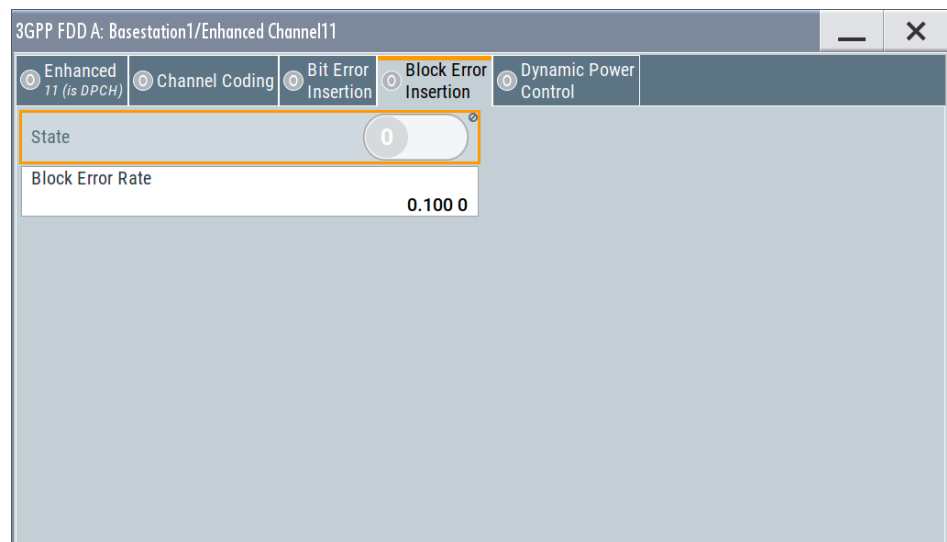

The dialogs provide the parameters for inserting errors into the data source and into the CRC checksum, for example, to check the bit and block error rate testers.

#### Bit Error State (Enhanced DPCHs)

Activates or deactivates bit error generation.

Bit errors are inserted into the data fields of the enhanced channels. When channel coding is active, it is possible to select the layer in which the errors are inserted (physical or transport layer).

When the data source is read out, individual bits are deliberately inverted at random points in the data bitstream at the specified error rate so that invalid signal is simulated.

Remote command:

```
[ :SOURce<hw> ] :BB:W3GPp:BSTation:ENHanced:CHANnel<ch0>:DPCH:
DERRor:BIT:STATe on page 347
```

**Bit Error Rate**

Sets the bit error rate.

Remote command:

`[ :SOURCE<hw> ] :BB:W3GPP:BSTation:ENHanced:CHANnel<ch0>:DPCH:DERRor:BIT:RATE` on page 347

**Insert Errors On**

Selects the layer in the coding process at which bit errors are inserted.

"Transport layer" Bit errors are inserted in the transport layer.  
This selection is only available when channel coding is active.

"Physical layer" Bit errors are inserted in the physical layer.

Remote command:

`[ :SOURCE<hw> ] :BB:W3GPP:BSTation:ENHanced:CHANnel<ch0>:DPCH:DERRor:BIT:LAYer` on page 346

**Block Error State**

Activates or deactivates block error generation.

The CRC checksum is determined and then the last bit is inverted at the specified error probability in order to simulate an invalid signal.

Remote command:

`[ :SOURCE<hw> ] :BB:W3GPP:BSTation:ENHanced:CHANnel<ch0>:DPCH:DERRor:BLOCK:STATE` on page 348

**Block Error Rate**

Sets block error rate.

Remote command:

`[ :SOURCE<hw> ] :BB:W3GPP:BSTation:ENHanced:CHANnel<ch0>:DPCH:DERRor:BLOCK:RATE` on page 348

**3.16.5 Dynamic power control - enhanced DPCHs BS1**

The "Dynamic Power Control" section comprises the settings necessary to configure the power of the selected enhanced channel. Power can be increased or decreased within the predefined dynamic range ("Up Range + Down Range") and with the predefined step size ("Power Step") depending on a control signal.

The control signal can be provided:

- Internally (TPC pattern)
- Manually

See [Mode](#).

The "Dynamic Power Control" is suitable for testing of closed (inner) loop Power Control in two test constellations:

- To test whether the DUT (receiver) correctly performs the SIR (signal to interference ratio) measurement and inserts the corresponding bits into the TPC field of its transmitting signal.  
The TPC control information is provided by an external "Dynamic Power Control" signal.
- To test whether the DUT (transmitter) responds with the correct output power to received TPC bits.  
To perform this test, use a data list adapted to the test condition as TPC data source. The TPC pattern is defined in the channel table.

The power change of the channels is performed by a switchover of a mapping table, controlled by the "Dynamic Power Control" signal. This signal is queried at the beginning of the pilot field. The limited number of mappings restricts the maximum dynamic range to 30 dB and the step width to min. 0.5 dB. The output power of each channel is thus limited to the dynamic range around the channel-specific start power.



#### Obtaining optimum signal quality

Do not set the "Power Up Range" higher than necessary because the mapping of the I/Q level in this range must be maintained as a level margin.

#### Example: Principle of the downlink dynamic power control

"Power Up Range = Power Down Range"

Channel#11/13, "Direction > Up"

Channel#12, "Direction > Down"

External control signal is provided

The [Figure 3-12](#) illustrates the adjustment in the channel power of these three enhanced channels.

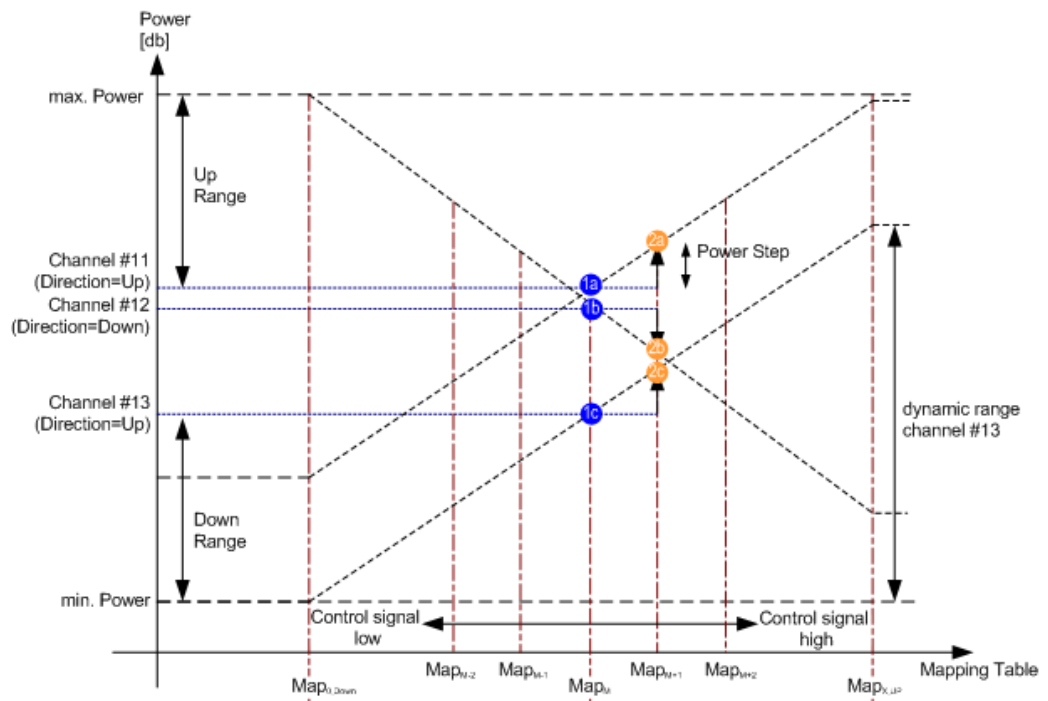

**Figure 3-12: Dynamic Power Control (downlink)**

1a, 1b, 1c = Start power of the corresponding channel#11 to 13

2a, 2b, 2c = Resulting channel power of channel#11 to 13 at high level of the control signal at the beginning of the pilot field.

The available mappings are shown on the X-axis with  $Map_M$  being the starting point. In this point, all channels have the start power as selected in the channel table.

At the beginning of the pilot field, the provided control signal is queried in each time-slot. Receiving of a logical "1" results in a switchover to the right mapping  $Map_{M+1}$ . This means an increase of the output power by "Power Step" for all channels with "Power Control Mode Up". In this example, the power of channel 12 is decreased by the same value (see [Figure 3-12](#)).

Receiving of a logical "0" results in a switchover to the left mapping  $Map_{M-1}$ . This means a reduction of the output power by "Power Step" for all channels with "Power Control Mode Down". The power of channel 12 is increased by the same value.

### How to access the settings

Access:

- ▶ Select "3GPP FDD > Channel Table > DPCH > Enhanced Settings > Dynamic Power Control".

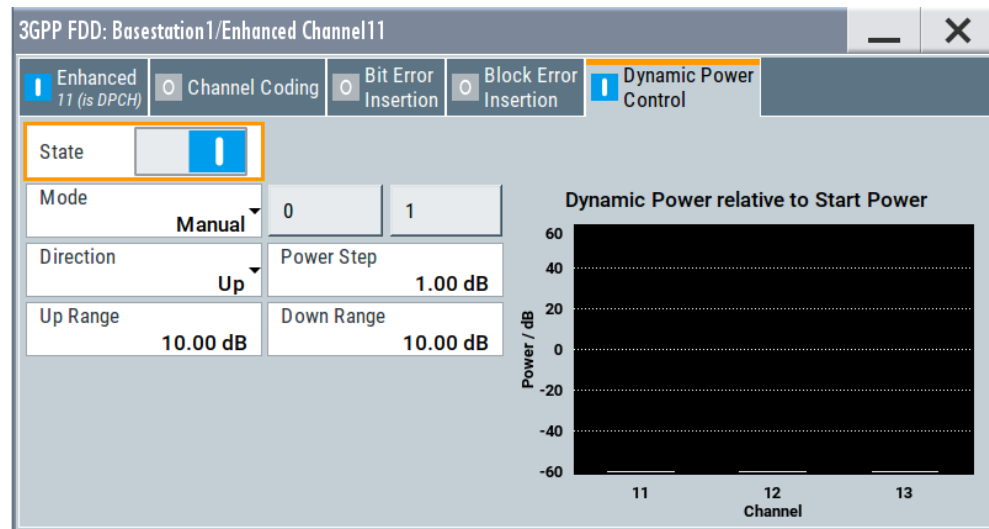

### Dynamic Power Control State

Activates or deactivates the "Dynamic Power Control" for the selected enhanced channel.

With activated Dynamic Power Control, the power of the enhanced channel can be increased or decreased within the predefined dynamic range ("Up Range" + "Down Range"). The power is varied with the predefined step size ("Power Step").

The "Direction" settings determine if the channel power is increased or decreased by a high level of the control signal.

Remote command:

```
[ :SOURCE<hw> ] :BB:W3GPP:BSTation:ENHanced:CHANnel<ch0>:DPCH:
DPControl:STATE on page 345
```

### Mode

Selects the control signal for Dynamic Power Control.

- "TPC" The TPC pattern is used for Dynamic Power Control. This selection corresponds to selection mis-use TPC for not enhanced DPCHs.
- "Manual" The control signal is manually produced by selecting one of the buttons 0 or 1. Button 1 corresponds to a positive control signal, button 0 to a negative control signal.  
The channel power is increased or decreased depending on the "Direction" setting by the selected power step.

Remote command:

```
[ :SOURCE<hw> ] :BB:W3GPP:BSTation:ENHanced:CHANnel<ch0>:DPCH:
DPControl:MODE on page 344
```

```
[ :SOURCE<hw> ] :BB:W3GPP:BSTation:ENHanced:CHANnel<ch0>:DPCH:
DPControl:STEP:MANual on page 345
```

### Direction

Determines whether the channel power is increased or decreased by a high level of the control signal (see [Figure 3-12](#)).

"Up" A high level of the control signal leads to an increase of channel power.

"Down" A high level of the control signal leads to a decrease of channel power.

Remote command:

`[ :SOURce<hw> ] :BB:W3GPp:BSTation:ENHanced:CHANnel<ch0>:DPCH:DPControl:DIRection` on page 344

### Power Step

Sets step width by which the channel power of the selected enhanced channel in the timeslot grid is increased or decreased. The variation applies to the set dynamic range ("Up Range + Down Range") and if "Dynamic Power Control" is enabled.

The start power of the channel is set in the "Power" column of the channel table.

Remote command:

`[ :SOURce<hw> ] :BB:W3GPp:BSTation:ENHanced:CHANnel<ch0>:DPCH:DPControl:STEP [ :EXTernal ]` on page 345

### Up Range / Down Range

Sets dynamic range by which – with "Dynamic Power Control" switched on – the channel powers of the enhanced channels can be increased. The resulting "Dynamic Power Control" dynamic range ("Up Range" + "Down Range") depends on the selected "Power Step" and is as follow:

- For "Power Step" < 1 dB, the dynamic range ("Up Range" + "Down Range") <= 30 dB
- For "Power Step" => 1 dB, the dynamic range ("Up Range" + "Down Range") <= 60 dB

Remote command:

`[ :SOURce<hw> ] :BB:W3GPp:BSTation<st>:ENHanced:CHANnel<ch0>:DPCH:DPControl:RANGe:UP` on page 344

`[ :SOURce<hw> ] :BB:W3GPp:BSTation:ENHanced:CHANnel<ch0>:DPCH:DPControl:RANGe:DOWN` on page 344

### Power Control Graph

Indicates the deviation of the channel power (delta POW) from the set power start value of the corresponding enhanced channels.

The graph is automatically displayed with "Dynamic Power Control" switched on.

**Note:** A realtime update of the display in the timeslot (= 0.667 ms) is not possible and is performed in a coarser time interval. The power control graph does not display fast channel power changes. The settled state of the control loop is however easy to recognize.

Remote command:

`[ :SOURce<hw> ] :BB:W3GPp:BSTation:ENHanced:CHANnel<ch0>:DPCH:DPControl [ :POWER ] ?` on page 346

### 3.17 S-CCPCH settings - BS channel table

Access:

- ▶ Select "3GPP FDD > BS > Channel Table > Channel type > S-CCPCH > DPCCH Settings > Config...".

3GPP FDD A: BS1/S-CCPCH5	
Common	
Data	20
Slot Format	0
TFCI <i>is Not Use</i>	<input type="checkbox"/>
TFCI	0
Pilot Length	0 Bit

The selected slot format determines the provided settings. Whenever the "TFCI State" and [Pilot Length] settings are changed, the slot format is adjusted accordingly.

#### Slot Structure (S-CCPCH)

Displays the slot structure.

TFCI	Data	Pilot
8	296	16

The structure of the slot depends on the selected slot format (see also 3GPP TS 25.211, Table 18: Secondary CCPCH fields)

#### Slot Format (S-CCPCH)

Displays the slot format.



The slot format displayed changes when a change is made to the TFCI and Pilot control field settings.

Remote command:

n.a.

#### Use TFCI

Activates TFCI field usage.

Remote command:

`[ :SOURce<hw> ] :BB:W3GPp:BSTation<st>:CHANnel<ch0>:DPCCh:TFCI:STATE` on page 290

The remote-control command is not valid for multi channel mode.

#### TFCI Value

Enters the value of the TFCI field (Transport Format Combination Indicator) . This value is used to select a combination of 30 bits, which is divided into two groups of 15 successive slots.

Remote command:

`[ :SOURce<hw> ] :BB:W3GPp:BSTation<st>:CHANnel<ch0>:DPCCh:TFCI` on page 290

The remote-control command is not valid for multi channel mode.

#### Pilot Length

Sets the length of the pilot fields.

The range of values for this parameter depends on the channel type and the symbol rate.

To achieve a constant slot length, the data fields are lengthened or shortened depending on the pilot length, as defined in the standard.

Remote command:

`[ :SOURce<hw> ] :BB:W3GPp:BSTation<st>:CHANnel<ch0>:DPCCh:PLENgtH` on page 288

The remote-control command is not valid for multi channel mode.

### 3.18 Config AICH/AP-AICH - BS channel table

Access:

- ▶ Select "3GPP FDD > BS > Channel Table > AICH/AP-AICH > DPCCH Sett > Config...".

The screenshot shows a configuration dialog titled "3GPP FDD A: BS1/AICH7". It features a title bar with standard window controls (minimize and close). The main content area contains two input fields. The first field, "Signature ACK/NACK Pattern", is highlighted with an orange border and contains the text "+000 0000...". The second field, "Access Slot", contains the value "0".

The dialog comprises the parameters for configuring the signature pattern and selecting the slot.

#### Signature ACK/NACK Pattern

Enters the 16-bit pattern for the ACK/NACK field.

This field is used by the base station to acknowledge, refuse or ignore requests of up to 16 user equipment.

- |              |  |
|--------------|--|
| ""+" = ACK"  | The ACK is sent. Transmission was successful and correct.                        |
| ""-" = NACK" | The NACK is sent. Transmission was not correct.                                  |
| ""0" = DTX"  | Nothing is sent. Transmission is interrupted (Discontinuous Transmission (DTX)). |

Remote command:

[ :SOURce<hw> ] :BB:W3GPp:BSTation<st>:CHANnel<ch0>:AICH:SAPattern  
on page 285

[ :SOURce<hw> ] :BB:W3GPp:BSTation<st>:CHANnel<ch0>:APAIch:  
SAPattern on page 285

#### **Access Slot**

Selects the slot in which the burst is transmitted.

Remote command:

[ :SOURce<hw> ] :BB:W3GPp:BSTation<st>:CHANnel<ch0>:AICH:ASLOt  
on page 284

[ :SOURce<hw> ] :BB:W3GPp:BSTation<st>:CHANnel<ch0>:APAIch:ASLOt  
on page 285

## **3.19 DPCCH settings - BS channel table**

The "DPCCH" settings dialog provides the parameters for configuring the fields of the dedicated physical control channel. The selected slot format determines the available settings.

### **3.19.1 Common slot structure (DPCCH)**

Access:

1. Select "3GPP FDD > BS > Channel Table > DPCH > DPCCH Settings > Config...".

2. Select "Common".

3GPP FDD A: BS1/DPCCH11			
Common	TPC Settings	DPCCH Power Offset	
Data 6	TPC 2	Data 24	Pilot 8
Slot Format			10
TFCI <i>is Not Use</i>			<input type="checkbox"/>
TFCI			0
Pilot Length			8 Bit
Multi Code State			<input type="checkbox"/>

This dialog contains the parameters for configuring the slot format. Whenever you change the "TFCI State" and "Pilot Length" settings, the slot format is adjusted accordingly.

Data	TPC	Data	Pilot
6	2	28	4

The upper section of the dialog shows the structure. It depends on the slot format-selected (see also 3GPP TS 25.211, Table 11: DPDCH and DPCCH fields)

#### Slot Format (DPCCH)

Displays the slot format.

The slot format displayed changes when a change is made to the TFCI and Pilot control field settings.

Remote command:  
n.a.

#### Use TFCI

Activates TFCI field usage.

Remote command:

```
[ :SOURCE<hw> ] :BB:W3GPP:BSTation<st>:CHANnel<ch0>:DPCCh:TFCI:
STATe on page 290
```

The remote-control command is not valid for multi channel mode.

#### TFCI Value

Enters the value of the TFCI field (Transport Format Combination Indicator) . This value is used to select a combination of 30 bits, which is divided into two groups of 15 successive slots.

Remote command:

```
[ :SOURCE<hw> ] :BB:W3GPP:BSTation<st>:CHANnel<ch0>:DPCCh:TFCI
on page 290
```

The remote-control command is not valid for multi channel mode.

#### Pilot Length

Sets the length of the pilot fields.

The range of values for this parameter depends on the channel type and the symbol rate.

To achieve a constant slot length, the data fields are lengthened or shortened depending on the pilot length, as defined in the standard.

Remote command:

```
[ :SOURCE<hw> ] :BB:W3GPP:BSTation<st>:CHANnel<ch0>:DPCCh:PLENght
on page 288
```

The remote-control command is not valid for multi channel mode.

#### Multicode State (DPCCH)

Activates multicode transmission.

Multicode transmission can be activated for a group of channels destined for the same receiver that is to say, belonging to a radio link. The first channel of this group is used as the master channel.

With multicode transmission, the common components (Pilot, TPC and TCFI) for all the channels are spread using the spreading code of the master channel.

This parameter is only available for the DPCHs.

**Note:** The remote-control command is not valid for multichannel mode.

Remote command:

```
[ :SOURCE<hw> ] :BB:W3GPP:BSTation<st>:CHANnel<ch0>:DPCCh:MCODE
on page 288
```

### 3.19.2 TPC settings

Access:

1. Select "3GPP FDD > BS > Channel Table > DPCH > DPCCH Settings > Config...".
2. Select "TPC Settings".

This tab provides the parameters for configuring the TPC data source and read out mode.

#### TPC Data Source (DPCCH)

Selects the data source for the TPC field (Transmit Power Control). This field is used to control the transmit power.

The following standard data sources are available:

- "All 0, All 1"  
An internally generated sequence containing 0 data or 1 data.
- "Pattern"  
An internally generated sequence according to a bit pattern.  
Use the "Pattern" box to define the bit pattern.
- "Data List / Select TPC List"  
A binary data from a data list, internally or externally generated.  
Select "Select TPC List" to access the standard "Select List" dialog.

- Select the "Select Data List > navigate to the list file \*.dm\_iqd > Select" to select an existing data list.
- Use the standard "File Manager" function to transfer external data lists to the instrument.
- Use the "New" and "Edit" functions to create internally new data list or to edit an existing one.

See also:

- Section "Modulation Data" in the R&S SMBV100B user manual.
- Section "File and Data Management" in the R&S SMBV100B user manual.
- Section "Data List Editor" in the R&S SMBV100B user manual.

Remote command:

`[ :SOURce<hw> ] :BB:W3GPp:BSTation<st>:CHANnel<ch0>:DPCCh:TPC:DATA`  
on page 290

`[ :SOURce<hw> ] :BB:W3GPp:BSTation<st>:CHANnel<ch0>:DPCCh:TPC:DATA:`  
`PATtern` on page 292

`[ :SOURce<hw> ] :BB:W3GPp:BSTation<st>:CHANnel<ch0>:DPCCh:TPC:DATA:`  
`DSElect` on page 291

The remote-control command is not valid for multichannel mode.

### TPC Read Out Mode (DPCCH)

Defines TPC data usage.

The TPC bits are used to signal the increase or reduction in transmit power to the called station. For all read out modes, 1 bit is taken from the data stream for the TPC field for each slot. The bit is entered into the bitstream several times, depending on the symbol rate. The difference between the modes lies in the usage of the TPC bits.

The different modes can be used to set a specific output power and then let the power oscillate around this value. For example, if the power is the pattern 11111, the power can be varied with "Single + alt. 01" and "Single + alt. 10". Thus, power measurements can be carried out at quasi-constant power.

- "Continuous:"  
The TPC bits are used cyclically.
- "Single + All 0"  
The TPC bits are used once, and then the TPC sequence is continued with 0 bits.
- "Single + All 1"  
The TPC bits are used once, and then the TPC sequence is continued with 1 bit.
- "Single + alt. 01"  
The TPC bits are used once and then the TPC sequence is continued with 0 bits and 1 bit alternately. Bits as appended in multiples, depending on the symbol rate, for example, 00001111.
- "Single + alt. 10"  
The TPC bits are used once and then the TPC sequence is continued with 1 bit and 0 bits alternately. Bits as appended in multiples, depending on by the symbol rate, for example, 11110000.

Use the parameter "Read Out Mode" together with the option "TPC For Output Power Control (Mis-) Use" to generate various output power profiles.

Remote command:

```
[ :SOURce<hw> ] :BB:W3Gpp:BSTation<st>:CHANnel<ch0>:DPCCh:TPC:READ
```

on page 293

The remote-control commands are not valid for multichannel mode.

### Misuse TPC for Output Power Control (DPCCH)

Defines "mis-" use of the TPC data.

The TPC bits are used to signal the increase or reduction in transmit power to the called station.

If "(Mis-) use TPC for output power control" is activated, the specified pattern is used to vary the intrinsic transmit power over time. A bit of this pattern is removed for each slot in order to increase (bit = "1") or reduce (bit = "0") the channel power by the specified power step ("Power Step"). The upper limit is 0 dB and the lower limit -60 dB.

The following envelope is produced with the settings:

- Channel power = 0 dB
- Power step = 1.0 dB
- Pattern = "001110100000011"
- "TPC Read Out Mode = Continuous"

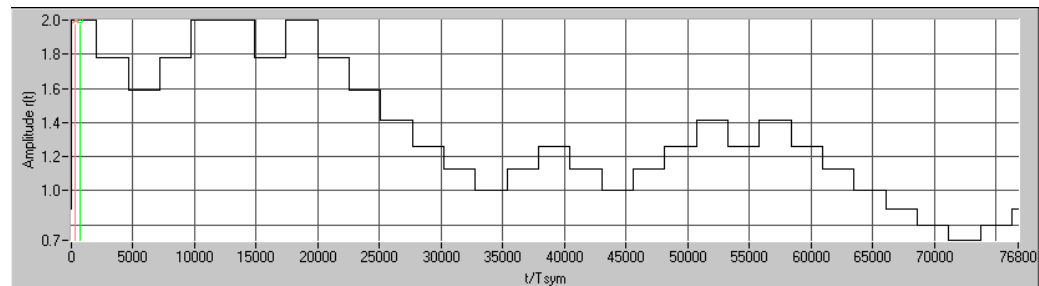

Figure 3-13: Dynamic change of channel power (continuous)

**Note:** The change in power is always carried out (as stipulated in the standard) at the start of the slot pilot field. Misuse TPC for Output Power Control is not available for enhanced DPCHs. Power Control via TPC pattern for enhanced channels can be selected for active Dynamic Power Control (see [Chapter 3.16.5, "Dynamic power control - enhanced DPCHs BS1"](#), on page 123).

Remote command:

```
[ :SOURce<hw> ] :BB:W3Gpp:BSTation<st>:CHANnel<ch0>:DPCCh:TPC:
MISuse
```

on page 292

The remote-control command is not valid for multichannel mode.

### TPC Power Step (DPCCH)

Sets the step width of the power change in dB for "(Mis-) use TPC for output power control".

**Note:** Misuse TPC for Output Power Control is not available for enhanced DPCHs. Power Control via TPC pattern for enhanced channels can be selected for active Dynamic Power Control (see [Chapter 3.16.5, "Dynamic power control - enhanced DPCHs BS1"](#), on page 123).



Remote command:

`[ :SOURCE<hw> ] :BB:W3GPP:BSTation<st>:CHANnel<ch0>:DPCCh:TPC:PSTep`  
on page 292

The remote-control command is not valid for multichannel mode.

### 3.19.3 DPCCH power offset

Access:

1. Select "3GPP FDD > BS > Channel Table > DPCH > DPCCH Settings > Config...".
2. Select "DPCCH Power Offset".

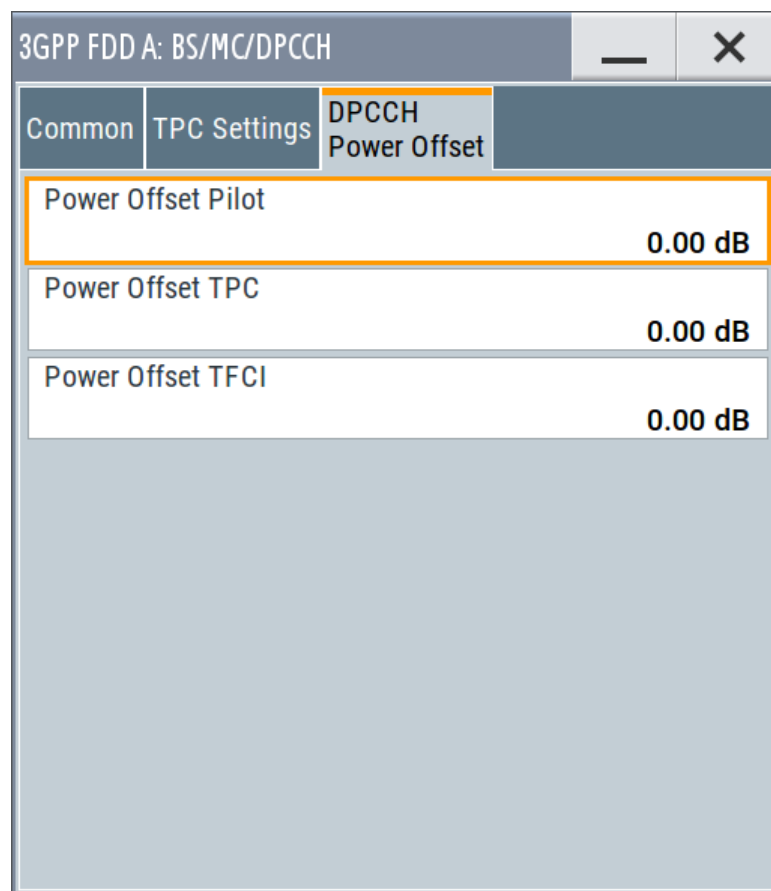

This tab provides the parameters for configuring power offsets of the control fields to the channel power.

#### Power Offset Pilot (DPCCH)

Sets the power offset of the pilot field to the channel power in dB.

Remote command:

`[ :SOURCE<hw> ] :BB:W3GPP:BSTation<st>:CHANnel<ch0>:DPCCh:POFFset:PILot`  
on page 289

The remote-control command is not valid for multichannel mode.

**Power Offset TPC (DPCCH)**

Sets the power offset of the TPC field to the channel power in dB.

Remote command:

```
[ :SOURCE<hw> ] :BB:W3GPP:BSTation<st>:CHANnel<ch0>:DPCCh:POFFset:
```

TPC on page 289

The remote-control command is not valid for multichannel mode.

**Power Offset TFCI (DPCCH)**

Sets the power offset of the TFCI field to the channel power in dB.

Remote command:

```
[ :SOURCE<hw> ] :BB:W3GPP:BSTation<st>:CHANnel<ch0>:DPCCh:POFFset:
```

TFCI on page 289

The remote-control command is not valid for multichannel mode.

## 3.20 Config E-AGCH - BS channel table

Access:

- ▶ Select "3GPP FDD > BS > Channel Table > E-AGCH > DPCCH Settings > Config...".

UEID	Absolute Grant Value Index	Absolute Grant Scope
0	0	0
All HARQ Processes		

The dialog provides the parameter required to configure the HSUPA control channels.

#### E-AGCH Information Field Coding

Enables/disables the information coding. Disabling this parameter corresponds to a standard operation, i.e. no coding is performed and the data is sent uncoded. Enabling this parameter allows you to configure the way the data is coded.

Remote command:

```
[ :SOURCE<hw> ] :BB:W3GPP:BSTation<st>:CHANnel<ch0> [ :HSUPa ] :EAGCh:IFCoding on page 317
```

#### E-DCH TTI

Switches between 2 ms and 10 ms. The processing duration also influences the number of used slots.

Remote command:

```
[ :SOURCE<hw> ] :BB:W3GPP:BSTation<st>:CHANnel<ch0> [ :HSUPa ] :EAGCh:TTIEdch on page 319
```

#### Number of Configurable TTIs

Sets the number of configurable TTIs.

Remote command:

```
[ :SOURCE<hw> ] :BB:W3GPP:BSTation<st>:CHANnel<ch0> [ :HSUPa ] :EAGCh:TTICount on page 318
```

#### E-AGCH Table

Comprises the parameters provided for an E-AGCH channel.

#### UEID (A-GCH) ← E-AGCH Table

Sets the UE Id for the selected TTI.

Remote command:

```
[ :SOURCE<hw> ] :BB:W3GPP:BSTation<st>:CHANnel<ch0> [ :HSUPa ] :EAGCh:TTI<di0>:UEID on page 318
```

#### Absolute Grant Value Index ← E-AGCH Table

Sets the Index for the selected TTI. According to the TS 25.212 (4.10.1 A.1), there is a cross-reference between the grant index and the grant value. The TTI configuration of the table is used cyclically. Depending on the selection made for the parameter "E-DCH TTI", each table row corresponds to a 2ms TTI or to a 10ms TTI.

Remote command:

```
[ :SOURCE<hw> ] :BB:W3GPP:BSTation<st>:CHANnel<ch0> [ :HSUPa ] :EAGCh:TTI<di0>:AGVIndex on page 318
```

#### Absolute Grant Scope ← E-AGCH Table

Sets the scope of the selected grant. According to the TS 25.321, the impact of each grant on the UE depends on this parameter.

For E-DCH TTI = 10ms, the "Absolute Grant Scope" is always All HARQ Processes.

Remote command:

```
[ :SOURce<hw> ] :BB:W3GPp:BSTation<st>:CHANnel<ch0> [ :HSUPa ] :EAGCh:
TTI<di0>:AGSCOpe on page 318
```

## 3.21 Config E-RGCH/E-HICH - BS channel table

Access:

- ▶ Select "3GPP FDD > BS > Channel Table > E-RGCH/E-HICH > DPCCH Settings > Config...".

3GPP FDD A: BS1/E-HICH9	
Type Of Cell	Serving Cell
E-DCH TTI	2 ms
Signature Hopping Pattern Index	0
ACK/NACK Pattern	+...
Tau <DPCH>	0 *256 Chips
Tau <E-HICH>	5 Slots

3GPP FDD A: BS1/E-RGCH9	
Type Of Cell	Serving Cell
E-DCH TTI	2 ms
Signature Hopping Pattern Index	0
Relative Grant Pattern	+...
Tau <DPCH>	0 *256 Chips
Tau <E-RGCH>	5 Slots

The dialogs provide the parameters for configuring the corresponding HSUPA control channels.

### Type of Cell

Switches between Serving Cell and Non-Serving Cell. The cell type determines the number of used slots.

Remote command:

```
[ :SOURce<hw> ] :BB:W3GPp:BSTation<st>:CHANnel<ch0> [ :HSUPa ] :ERGCh:
CTYPe on page 321
```

```
[ :SOURce<hw> ] :BB:W3GPp:BSTation<st>:CHANnel<ch0> [ :HSUPa ] :EHICH:
CTYPe on page 319
```

### E-DCH TTI

Switches between 2 ms and 10 ms. The processing duration also influences the number of used slots.

Remote command:

`[ :SOURce<hw> ] :BB:W3GPP:BSTation<st>:CHANnel<ch0> [ :HSUPa ] :ERGCh:TTIEdch` on page 323

`[ :SOURce<hw> ] :BB:W3GPP:BSTation<st>:CHANnel<ch0> [ :HSUPa ] :EHICH:TTIEdch` on page 321

### Signature Hopping Pattern Index – HSUPA BS

Enters a value that identifies the user equipment. The values are defined in TS 25.211.

Remote command:

`[ :SOURce<hw> ] :BB:W3GPP:BSTation<st>:CHANnel<ch0> [ :HSUPa ] :ERGCh:SSINdex` on page 322

`[ :SOURce<hw> ] :BB:W3GPP:BSTation<st>:CHANnel<ch0> [ :HSUPa ] :EHICH:SSINdex` on page 321

### Relative Grant Pattern

(This feature is available for E-RGCH only.)

Enters a pattern: 0 = Hold, + = Up, - = Down.

**Note:** Pattern + is entered using the numeric key 1. Pattern - is entered via the numeric key +/-.

For Non-Serving Cell, "1" is not allowed.

Remote command:

`[ :SOURce<hw> ] :BB:W3GPP:BSTation<st>:CHANnel<ch0> [ :HSUPa ] :ERGCh:RGPattern` on page 322

### ACK/NACK Pattern

(This feature is available for E-HICH only.)

Enters the pattern for the ACK/NACK field.

For Non-Serving Cell, only "+" (ACK) and "0" (no signal) is allowed. For Serving Cells only "+" (ACK) and "-" (NACK) is allowed.

**Note:** Pattern + is entered using the numeric key 1. Pattern - is entered via the numeric key +/-.

Remote command:

`[ :SOURce<hw> ] :BB:W3GPP:BSTation<st>:CHANnel<ch0> [ :HSUPa ] :EHICH:RGPattern` on page 320

### Tau DPCH

Enters the offset of the downlink dedicated offset channels.

Remote command:

`[ :SOURce<hw> ] :BB:W3GPP:BSTation<st>:CHANnel<ch0> [ :HSUPa ] :EHICH:DTAU` on page 320

`[ :SOURce<hw> ] :BB:W3GPP:BSTation<st>:CHANnel<ch0> [ :HSUPa ] :ERGCh:DTAU` on page 321

### Tau E-RGCH/E-HICH

Displays the offset of the P-CCPCH frame boundary.

Remote command:

`[ :SOURCE<hw> ] :BB:W3GPP:BSTation<st>:CHANnel<ch0> [ :HSUPa ] :EHICH:ETAU? on page 320`

`[ :SOURCE<hw> ] :BB:W3GPP:BSTation<st>:CHANnel<ch0> [ :HSUPa ] :ERGCh:ETAU? on page 322`

## 3.22 Config F-DPCH - BS channel table

This section provides the description of the setting parameters for the fractional dedicated physical control channel.

### 3.22.1 Common settings

Access:

1. Select "3GPP FDD > BS > Channel Table > F-DPCH > DPCCH Settings > Config...".
2. Select "Common".

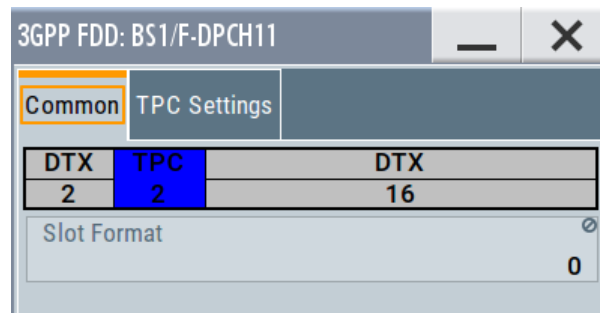

The "Common" tab shows the slot structure and format of the F-DPCH channel.

#### Slot Format (F-DPCH)

Displays the slot format as selected with the parameter "Slot Format" in the Channel Table.

The corresponding slot structure is displayed above the parameter.

DTX	TPC	DTX
2	2	16

Option: R&S SMBVB-K83 for slot formats 1 to 9

The difference between the F-DPCH slot formats is the position of the 2 bits TPC field.

Remote command:

n.a.

### 3.22.2 TPC settings

Access:

1. Select "3GPP FDD > BS > Channel Table > F-DPCCH > DPCCH Settings > Config...".
2. Select "TPC Settings".

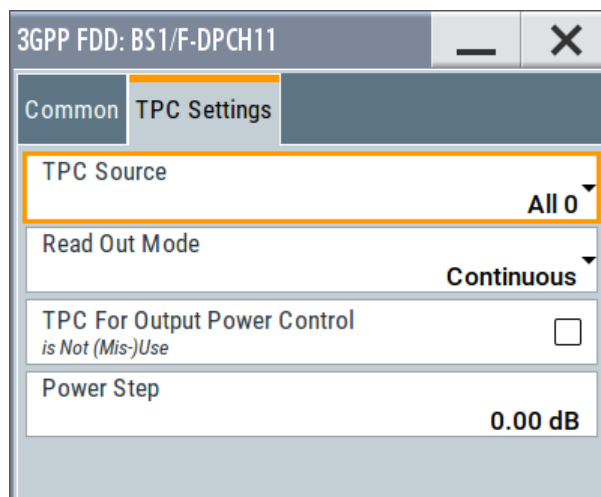

This tab contains the parameters for configuring the TPC data source and read out mode.

#### TPC Source

Selects the data source for the F-DPCH channel.

The following standard data sources are available:

- "All 0, All 1"  
An internally generated sequence containing 0 data or 1 data.
- "PNxx"  
An internally generated pseudo-random noise sequence.
- "Pattern"  
An internally generated sequence according to a bit pattern.  
Use the "Pattern" box to define the bit pattern.
- "Data List/Select DList"  
A binary data from a data list, internally or externally generated.  
Select "Select DList" to access the standard "Select List" dialog.
  - Select the "Select Data List > navigate to the list file \*.dm\_iqd > Select" to select an existing data list.
  - Use the "New" and "Edit" functions to create internally new data list or to edit an existing one.
  - Use the standard "File Manager" function to transfer external data lists to the instrument.

See also:

- Section "Modulation Data" in the R&S SMBV100B user manual.
- Section "File and Data Management" in the R&S SMBV100B user manual.

- Section "Data List Editor" in the R&S SMBV100B user manual

Remote command:

`[ :SOURCE<hw> ] :BB:W3GPP:BSTation<st>:CHANnel<ch0>:FDPCh:DPCCCh:TPC:DATA` on page 293

`[ :SOURCE<hw> ] :BB:W3GPP:BSTation<st>:CHANnel<ch0>:FDPCh:DPCCCh:TPC:DATA:DSElect` on page 294

`[ :SOURCE<hw> ] :BB:W3GPP:BSTation<st>:CHANnel<ch0>:FDPCh:DPCCCh:TPC:DATA:PATtern` on page 295

### TPC Read Out Mode (F-DPCH)

Defines TPC data usage.

The TPC bits are used to signal the increase or reduction in transmit power to the called station. For all read out modes, 1 bit is taken from the data stream for the TPC field for each slot. The bit is entered into the bitstream several times, depending on the symbol rate. The difference between the modes lies in the usage of the TPC bits.

The different modes can be used to set a specific output power and then let the power oscillate around this value. For example, if the power is the pattern 11111, the power can be varied with "Single + alt. 01" and "Single + alt. 10". Thus, power measurements can be carried out at quasi-constant power.

- "Continuous:"  
The TPC bits are used cyclically.
- "Single + All 0"  
The TPC bits are used once, and then the TPC sequence is continued with 0 bits.
- "Single + All 1"  
The TPC bits are used once, and then the TPC sequence is continued with 1 bit.
- "Single + alt. 01"  
The TPC bits are used once and then the TPC sequence is continued with 0 bits and 1 bit alternately. Bits as appended in multiples, depending on the symbol rate, for example, 00001111.
- "Single + alt. 10"  
The TPC bits are used once and then the TPC sequence is continued with 1 bit and 0 bits alternately. Bits as appended in multiples, depending on by the symbol rate, for example, 11110000.

Use the parameter "Read Out Mode" together with the option "TPC For Output Power Control (Mis-) Use" to generate various output power profiles.

Remote command:

`[ :SOURCE<hw> ] :BB:W3GPP:BSTation<st>:CHANnel<ch0>:FDPCh:DPCCCh:TPC:READ` on page 296

### TPC For Output Power Control (Mis-) Use

Defines "mis-" use of the TPC data.

The TPC bits are used to signal the increase or reduction in transmit power to the called station.

If "(Mis-) use TPC for output power control" is activated, the specified pattern is used to vary the intrinsic transmit power over time. A bit of this pattern is removed for each slot in order to increase (bit = "1") or reduce (bit = "0") the channel power by the specified power step ("Power Step"). The upper limit is 0 dB and the lower limit -60 dB.



The following envelope is produced with the settings:

- Channel power = 0 dB
- Power step = 1.0 dB
- Pattern = "001110100000011"
- "TPC Read Out Mode = Continuous"

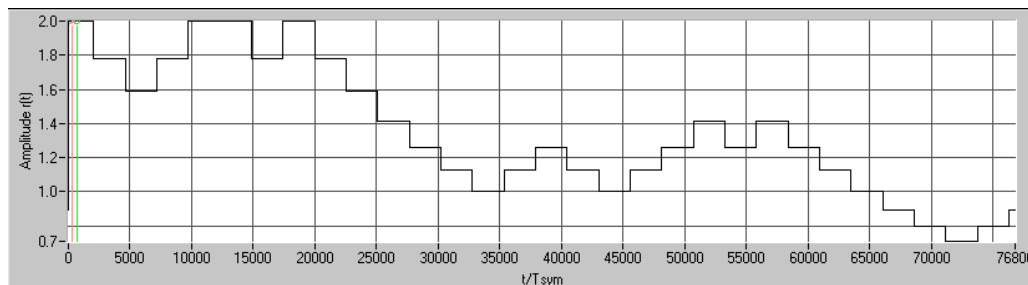

Remote command:

```
[ :SOURce<hw> ] :BB:W3Gpp:BSTation<st>:CHANnel<ch0>:FDPCh:DPCCh:
TPC:MIUse on page 295
```

#### TPC Power Step (F-DPCH)

Sets the step width of the power change in dB for "(Mis-) use TPC for output power control".

Remote command:

```
[ :SOURce<hw> ] :BB:W3Gpp:BSTation<st>:CHANnel<ch0>:FDPCh:DPCCh:
TPC:PSTep on page 296
```

## 3.23 Multi channel assistant - BS

Access:

- ▶ Select "3GPP FDD > BS > Channel Table > Multi Channel Assistant".

3GPP FDD A Basestation1: Multi Channel Assistant		Common	
Start Channel Number	11	Stop Channel Number	11
Channel Type	DPCH		DPCH
Channelization Code	0	Channelization Code Step	0
Power	0.00 dB	Power Step	0.00 dB
Data Source	Pattern	Pattern	0...
Channel State	<input type="checkbox"/>		
<input checked="" type="checkbox"/> Accept			

The "Multi Channel Assistant" allows several channels to be set simultaneously and is only available for the channel types DPCH, HS-SCCH, HS QPSK, HS 16QAM and HS 64QAM.

Enhanced state is automatically deactivated. The channel table is only filled with new values when the "Accept" button is pressed.

### Start Channel Number

Enters the index for the start channel of the channel range that is set jointly.

Remote command:

n.a.

### Stop Channel Number

Enters the index for the stop channel of the channel range that is set jointly.

Remote command:

n.a.

### Channel Type

Enters the channel type for the channel range that is set jointly. Available for selection are DPCH, HS-SCCH, HS QPSK, HS 16QAM, or HS 64QAM.

Remote command:

n.a.

### Channelization Code

Sets the channelization code for the start channel.

The channel is spread with the specified channelization code (spreading code).

The range of values of the channelization code depends on the symbol rate of the channel.

The range of values runs from 0 to  $(\text{chip\_rate}/\text{symbol\_rate}) - 1$

Remote command:

n.a.

### Channelization Code Step

Sets the step width for the channelization code from channel to channel.

The valid range of values for the channelization code of an individual channel must not be exceeded. If the range of values is exceeded, the channelization code is limited automatically.

Remote command:

n.a.

### Power

Sets the channel power of the start channel in dB.

The power entered is relative to the powers of the other channels and does not initially relate to the "Level" power display. If [Adjust Total Power To 0 dB](#) is executed (top level of the 3GPP dialog), all the power data is relative to 0 dB.

**Note:** The maximum channel power of 0 dB applies to non-blanked channels (duty cycle 100%). With blanked channels, the maximum value can be increased to values greater than 0 dB .

To increase the value, use the parameter "Adjust Total Power" where the maximum value is calculated as  $10 \cdot \log_{10}(1/\text{duty\_cycle})$ .

The "Power" value is also the starting power of the channel for "Misuse TPC" and "Dynamic Power Control".

Remote command:

n.a.

### Power Step

Enters the step width for the change of channel power from channel to channel.

The valid range of values must not be exceeded. If the range of values is exceeded, the power is automatically limited to the permissible of -80 dB to 0 dB.

Remote command:

n.a.

### Data Source

Selects data source.

The following standard data sources are available:

- "All 0, All 1"  
An internally generated sequence containing 0 data or 1 data.
- "PNxx"  
An internally generated pseudo-random noise sequence.
- "Pattern"  
An internally generated sequence according to a bit pattern.

Use the "Pattern" box to define the bit pattern.

- "Data List/Select DList"

A binary data from a data list, internally or externally generated.

Select "Select DList" to access the standard "Select List" dialog.

- Select the "Select Data List > navigate to the list file \*.dm\_iqd > Select" to select an existing data list.
- Use the "New" and "Edit" functions to create internally new data list or to edit an existing one.
- Use the standard "File Manager" function to transfer external data lists to the instrument.

See also:

- Section "Modulation Data" in the R&S SMBV100B user manual.
- Section "File and Data Management" in the R&S SMBV100B user manual.
- Section "Data List Editor" in the R&S SMBV100B user manual

Remote command:

n.a.

### **Channel State**

Activates or deactivates all the channels in the set channel range.

Remote command:

n.a.

### **Accept**

Executes automatic completion of the channel table in accordance with the parameters set.

Remote command:

n.a.

### **DPCH**

Access:

Select "3GPP FDD > BS > Channel Table > Multi Channel Assistant > DPCH"

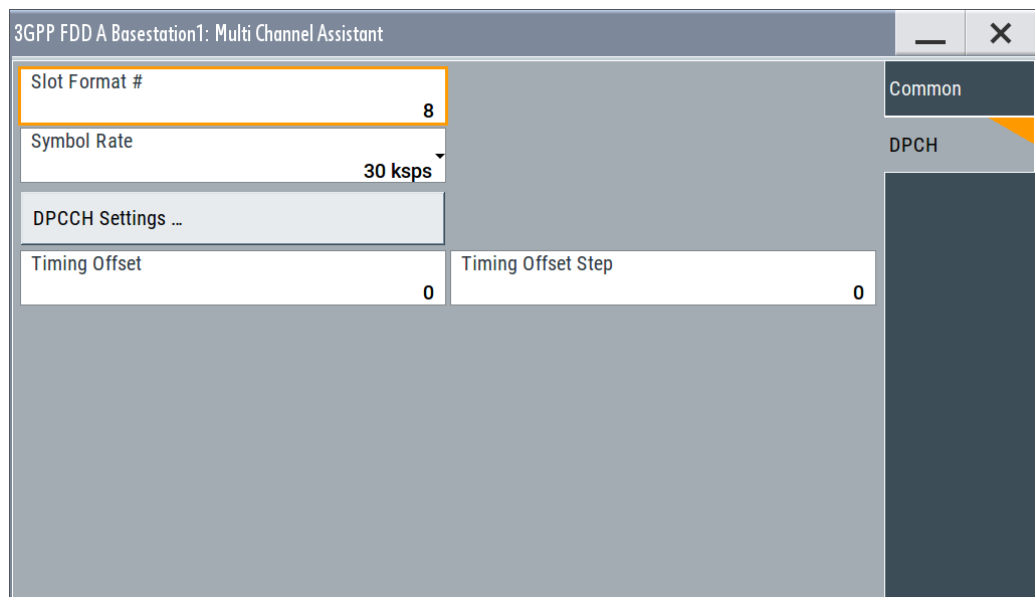
**Slot Format ← DPCH**

Enters the slot format.

For DPCH channels, the slot formats are 0 to 16.

A slot format defines the structure of a slot made of data and control fields and includes the symbol rate.

The individual parameters of a slot can later be changed, with the slot format being adjusted, if necessary.

This parameter is not available for high-speed channels.

**Note:** For the "DPCCH Settings", this value is read-only.

Remote command:

n.a.

**Symbol Rate ← DPCH**

Sets the symbol rate. The range of values depends on the channel selected.

The symbol rate is determined by the slot format set. A change in the symbol rate leads automatically to an adjustment of the slot format.

Remote command:

n.a.

**DPCCH Settings ← DPCH**

Accesses the dialog for configuring DPCCH channels, see [Chapter 3.19, "DPCCH settings - BS channel table"](#), on page 131.

Remote command:

n.a.

In contrast to setting a single channel, the remote control commands are not available.

**Timing Offset ← DPCH**

Sets the timing offset for the start channel.

The timing offset determines the shift of the source symbols before interleaving.

The absolute starting time of the frame (slot 0) is shifted relative to the start of the scrambling code sequence by the `timing offset * 256 chips`. This means that whatever the symbol rate, the resolution of the timing offset is always 256 chips.

This procedure is used to reduce the crest factor. A good way to obtain a lower crest factor is to use an offset of 1 from channel to channel, for example.

Remote command:

n.a.

#### **Timing Offset Step ← DPCH**

Sets the step width for the timing offset from channel to channel.

The valid range of values must not be exceeded. If the range of values is exceeded, the timing offset is automatically limited to the permissible range.

Remote command:

n.a.

## **3.24 User equipment configuration (UE)**

Access:

1. Select "3GPP FDD > Link Direction > Uplink".
2. Select "3GPP FDD > User Equipment > UE 1/2/3/4".

The "User Equipment" dialog provides the parameters for configuring the general settings of mobile terminal equipment and specific UE-related settings. It also provides a channel table with graphical display of the structure of the currently selected channel.

A user equipment has a maximum of 6 DPDCHs, with parameters largely prescribed by the 3GPP specification TS 25.211. To simplify operation, the settings are grouped into three modes with following main differences:

- With the "DPCCH + DPDCH" mode, the HSDPA channel HS-DPCCH and the HSUPA channels E-DPCCH and E-DPDCH can be activated.
- With the "PRACH only" and "PCPCH only" modes, there is also a choice between "Standard" (all parameters can be set) and "Preamble only" (only the preamble can be set).

The dialog of each particular mode only displays the parameters that are relevant.

The DPCCH and one DPDCH of user equipment 1 are generated in realtime (enhanced mode). Depending on the actual configurations, other channels of user equipment 1 can also be generated in real time. The PRACH and PCPCH channels are not generated in real time.

### 3.24.1 General settings

Access:

- ▶ Select "General".

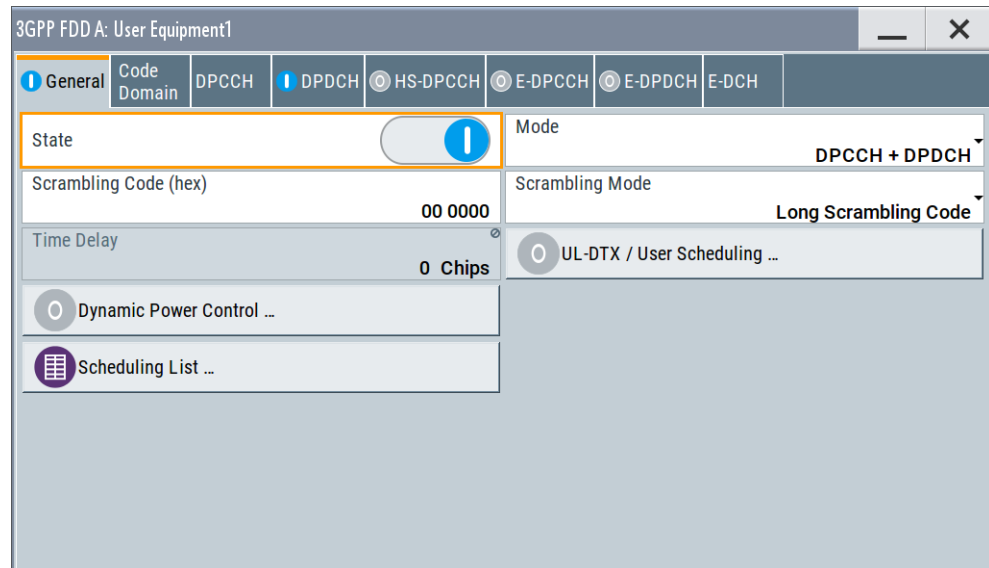

The "General" tab comprises the settings necessary to select the mode, e.g. "PRACH Settings" or "DPCCH Settings".

#### State

Activates or deactivates the selected user equipment. The number of the selected user equipment is specified in the menu header.

Remote command:

`[ :SOURce<hw> ] :BB:W3Gpp:MSTation<st>:STATE` on page 354

#### Mode

Selects the mode in which the user equipment is to work. The lower part of the menu changes in accordance with the mode. The following modes are available:

"PRACH only - Standard"

In this mode, the instrument generates a single physical random access channel (PRACH). This channel is needed to set up the connection between the user equipment and the base station. All the PRACH parameters can be set in the PRACH Settings section (see [Chapter 3.36, "PRACH settings - UE"](#), on page 222).

"PRACH only - Preamble only"

In this mode, the instrument only generates the preamble of a physical random access channel (PRACH). Only the PRACH preamble parameters can be set in the PRACH Settings section. This mode is needed for test case 8.8, according to 3GPP TS 25.141.

**"PCPCH only - Standard"**

In this mode, the instrument generates a single physical common packet channel (PCPCH). This channel is used to transmit packet-oriented services (e.g. SMS). The specific PCPCH parameters can be set in the PCPCH Settings section (see [Chapter 3.37, "PCPCH settings - UE"](#), on page 233).

**"PCPCH only - Preamble only"**

In this mode, the instrument only generates the preamble of a physical common packet channel (PCPCH). Only the PRACH preamble parameters can be set in the PCPCH Settings section. This mode is needed for test case 8.9, according to 3GPP TS 25.141.

**"DPCCH + DPDCH"**

In this mode, the instrument generates a control channel (DPCCH) and up to six data channels (DPDCH). This mode corresponds to the standard mode of user equipment during voice and data transmission.

In addition, the HS-DPCCH, E-DPCCH and E-DPDCH channels can be activated.

Channel-specific parameters can be set in the section of the individual channels.

The DPCCH and one DPDCH of user equipment 1 are generated in realtime (enhanced mode). Depending on the actual configurations, other channels of user equipment 1 can also be generated in realtime.

Remote command:

`[ :SOURCE<hw> ] :BB:W3GPP:MSTation<st>:MODE` on page 353

**Scrambling Code (hex)**

Sets the scrambling code.

The scrambling code is used to distinguish the transmitter (UE) by transmitter-dependent scrambling. Hexadecimal values are entered. Long or short scrambling codes can be generated (see also [Chapter 2.3.1, "Scrambling code generator"](#), on page 17).

Remote command:

`[ :SOURCE<hw> ] :BB:W3GPP:MSTation<st>:SCODE` on page 354

**Scrambling Mode**

Sets the type of scrambling code.

With scrambling code, a distinction is made between long and short scrambling code (see also [Section Scrambling code generator](#)).

"Off" Disables scrambling code for test purposes.

"Long Scrambling Code" Sets the long scrambling code.

"Short Scrambling Code" (only modes "DPCCH + DPDCH" and "PCPCH only")  
Sets short scrambling code.  
The short scrambling code is only standardized for DPCCH and DPDCH channels. But it can also be generated for the PCPCH channel for test purposes.



Remote command:

[ :SOURce<hw> ] :BB:W3GPP:MSTation<st>:SCODE:MODE on page 354

#### Time Delay

Enters the time delay of the signal of the selected user equipment compared to the signal of user equipment 1.

Remote command:

[ :SOURce<hw> ] :BB:W3GPP:MSTation<st>:TDElay on page 355

#### UL-DTX .../ User Scheduling

Option: R&S SMBVB-K83, UE 1 and DPCCH+DPDCH mode

Accesses the dialog for configuring an uplink discontinuous transmission (UL-DTX) or applying user scheduling, see [Chapter 3.25, "UL-DTX/user scheduling - UE"](#), on page 154.

Remote command:

n.a.

#### Dynamic Power Control

(for UE 1 and DPCCH+DPDCH mode only)

Accesses the dialog for configuring the "Dynamic Power Control" settings, see [Chapter 3.26, "Dynamic power control - UE"](#), on page 157.

Remote command:

n.a.

#### Scheduling List

Accesses the dialog displaying the current scheduling per UE, see [Chapter 3.27, "Scheduling list"](#), on page 161.

### 3.24.2 Channel settings

The settings and the dialogs of the individual channels are described in the corresponding sections, see:

- [Chapter 3.28, "DPCCH settings - UE"](#), on page 162
- [Chapter 3.29, "DPDCH settings - UE"](#), on page 168
- [Chapter 3.30, "HS-DPCCH settings - UE"](#), on page 173
- [Chapter 3.31, "E-DPCCH settings - UE"](#), on page 194
- [Chapter 3.33, "E-DPDCH settings - UE"](#), on page 206
- [Chapter 3.34, "E-DCH scheduling - UE"](#), on page 209

## 3.25 UL-DTX/user scheduling - UE



Option: R&S SMBVB-K83.

1. To access the "**UL-DTX**" settings, select "3GPP FDD > Link Direction > Uplink / Reverse > User Equipments > UE".
2. Select "Mode > DPCCH + DPDCH".
3. Select "UL-DTX / User Scheduling..."
4. Select "Mode > UL-DTX".

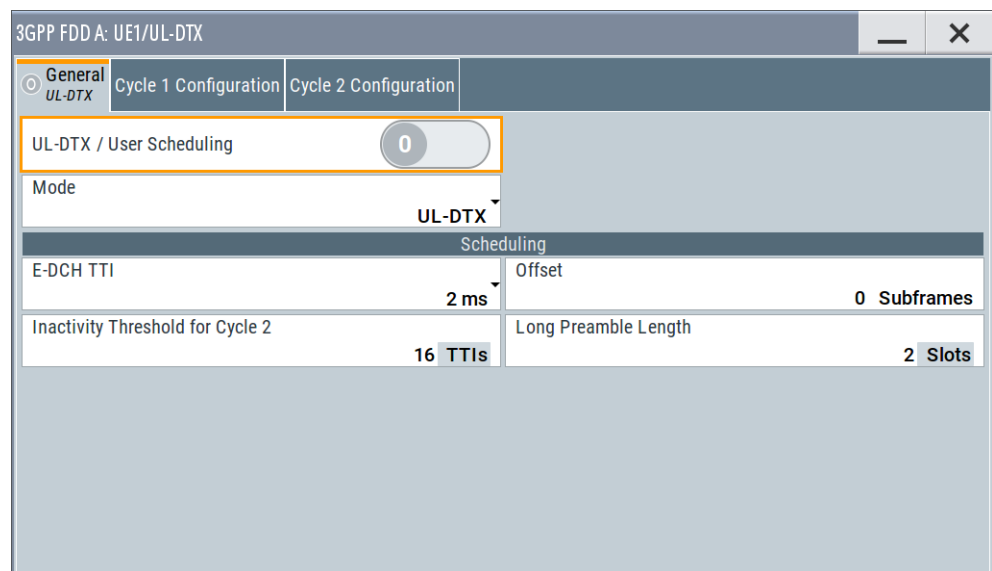

The "UE /UL-DTX" contains the parameters for adjusting the UL-DTX settings. The provided UL-DTX functionality is fully compliant with 3GPP TS 25.214. All dependencies from E-DCH transmissions, HARQ-ACK transmissions or CQI transmissions on the DPCCH are respected.

For UL-DTX, the dialog provides settings to configure the start offset, the threshold time for switching to UE-DTX cycle 2 and the DPCCH activity patterns for UE-DTX cycle 1/2. You can set the frequentness of the DPCCH bursts, the DPCCH bursts length (without pre- and postamble) and configure the length of the longer preamble for the UE-DTX cycle 2.



In this instrument, the signal generation starts with UE-DTX cycle 2. To trigger a switching to a UE-DTX cycle 1, activate the channels E-DPCCH/E-DPDCH and configure the "[E-DCH Scheduling](#)" parameters.



Use the [Scheduling list](#) to display the UL-DTX burst pattern and transmissions of E-DCH and HS-DPCCH, as well as the impact on the UL-DPCCH transmissions or the configured uplink user scheduling.

### Detailed information

For detailed information on the provided functions, like explanation of the UL-DTX principle, description of the user scheduling file format, possible interdependencies, refer to:

- [Chapter 2.3.19, "Uplink discontinuous transmission \(UL DTX\)"](#), on page 41

For an example on how to use these functions, refer to:

- [Chapter 4.3, "Configuring UL-DTX transmission and visualizing the scheduling"](#), on page 254

### UL-DTX... / User Scheduling State

Depending on the selected "Mode", enables/disables:

- Uplink discontinuous transmission (UL-DTX), i.e. uplink DPCCH gating  
Enabling the UL-DTX deactivates the DPDCH and the HSUPA FRC.

Remote command:

`[ :SOURCE<hw> ] :BB:W3GPP:MSTation:UDTX:STATE` on page 424

### Mode

The parameter is fixed to "UL-DTX".

Remote command:

`[ :SOURCE<hw> ] :BB:W3GPP:MSTation:UDTX:MODE` on page 424

### Scheduling

This section comprises the common settings for both UL-DTX cycles.

#### E-DCH TTI ← Scheduling

Sets the duration of a E-DCH TTI.

By enabled UL-DTX, the value configured with this parameter sets the value for the parameter "E-DCH TTI" in the "UE1 > E-DCH Scheduling" dialog.

Remote command:

`[ :SOURCE<hw> ] :BB:W3GPP:MSTation:UDTX:TTIEdch` on page 425

#### Offset ← Scheduling

Sets the parameter UE\_DTX\_DRX\_Offset and determines the start offset in subframes of the first uplink DPCCH burst (after the preamble). The offset is applied only for bursts belonging to the DPCCH burst pattern; HS-DPCCH or E-DCH transmissions are not affected.

The parameter UE\_DTX\_DRX\_Offset is used to calculate the first subframe in each UL DPCCH burst pattern.

- For DTX cycle 1:  
 $(5 \cdot \text{CFN} - \text{UE\_DTX\_DRX\_Offset} + \text{Subframe\#}) \bmod \text{UE\_DTX\_Cycle\_1} = 0$
- For DTX cycle 2:  
 $(5 \cdot \text{CFN} - \text{UE\_DTX\_DRX\_Offset} + \text{Subframe\#}) \bmod \text{UE\_DTX\_Cycle\_2} = 0$

The offset is used to shift the DPCCH burst pattern of the different UEs so that they have the DPCCH transmission phase in their DTX cycles at different times.

Remote command:

`[ :SOURCE<hw> ] :BB:W3GPP:MSTation:UDTX:OFFSet` on page 425

#### Inactivity Threshold for Cycle 2 ← Scheduling

Defines the number of consecutive E-DCH TTIs without an E-DCH transmission, after which the UE moves immediately from UE-DTX cycle 1 to using UE-DTX cycle 2 (see [Figure 4-2](#)).

**Note:** In this implementation, the signal generation starts with UE-DTX cycle 2. To trigger a switching to a UE-DTX cycle 1, activate the channels E-DPCCH/E-DPDCH and configure the "E-DCH Scheduling" parameters.

Remote command:

`[ :SOURCE<hw> ] :BB:W3GPP:MSTation:UDTX:ITHReshold` on page 425

#### Long Preamble Length ← Scheduling

Determines the length in slots of the preamble associated with the UE-DTX cycle 2.

Remote command:

`[ :SOURCE<hw> ] :BB:W3GPP:MSTation:UDTX:LPLength` on page 425

#### Cycle 1 / Cycle 2 Configuration

Comprises the settings for configuring the frequentness of the DPCCH bursts and the DPCCH bursts length (without pre- and postamble).

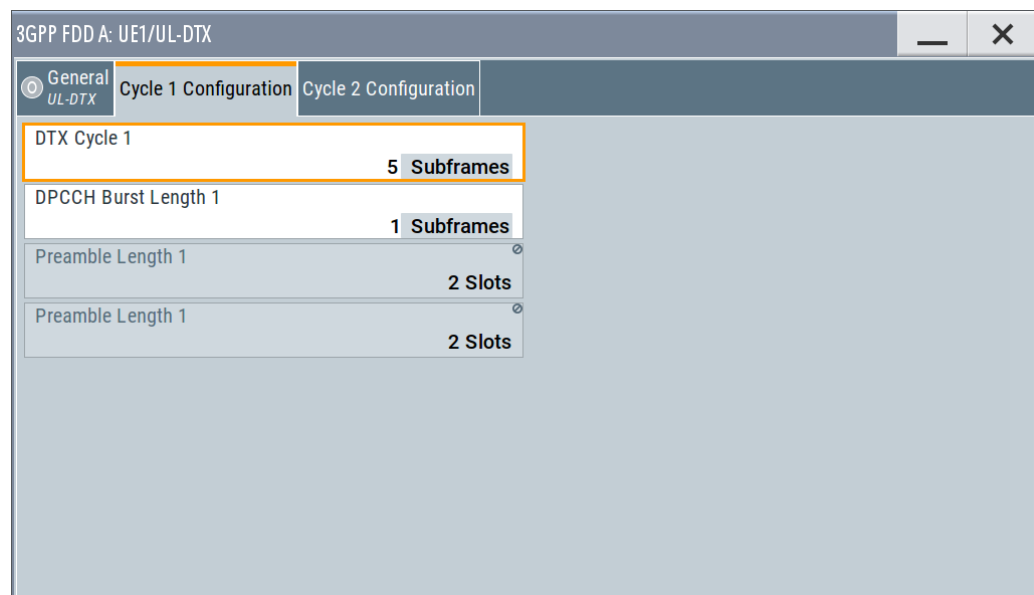

#### DTX Cycle 1 / DTX Cycle 2 ← Cycle 1 / Cycle 2 Configuration

Sets the offset in subframe between two consecutive DPCCH bursts within the corresponding UE-DTX cycle, i.e. determines how often the DPCCH bursts are transmitted (see [Figure 4-2](#)).

The UE-DTX cycle 2 is an integer multiple of the UE-DTX cycle 1, i.e. has less frequent DPCCH transmission instants.

Remote command:

[ :SOURce<hw> ] :BB:W3GPp:MSTation:UDTX:CYCLe<ch> on page 426

### DPCCH Burst Length 1 / DPCCH Burst Length 2 ← Cycle 1 / Cycle 2 Configuration

Determines the uplink DPCCH burst length in subframes without the preamble and postamble, when the corresponding UE-DTX cycle is applied.

Remote command:

[ :SOURce<hw> ] :BB:W3GPp:MSTation:UDTX:BURSt<ch> on page 426

### Preamble Length 1 / Preamble Length 2 ← Cycle 1 / Cycle 2 Configuration

Displays the preamble length in slots, when the corresponding UE-DTX cycle is applied.

The preamble length is fixed to two slots.

Remote command:

[ :SOURce<hw> ] :BB:W3GPp:MSTation:UDTX:PREamble<ch>? on page 426

### Postamble Length 1 / Postamble Length 2 ← Cycle 1 / Cycle 2 Configuration

Displays the postamble length in slots, when the corresponding UE-DTX cycle is applied.

The postamble length is fixed to one slot.

Remote command:

[ :SOURce<hw> ] :BB:W3GPp:MSTation:UDTX:POSTamble<ch>? on page 427

## 3.26 Dynamic power control - UE

Access:

- ▶ Select "3GPP FDD > User Equipment > UE > Dynamic Power Control".

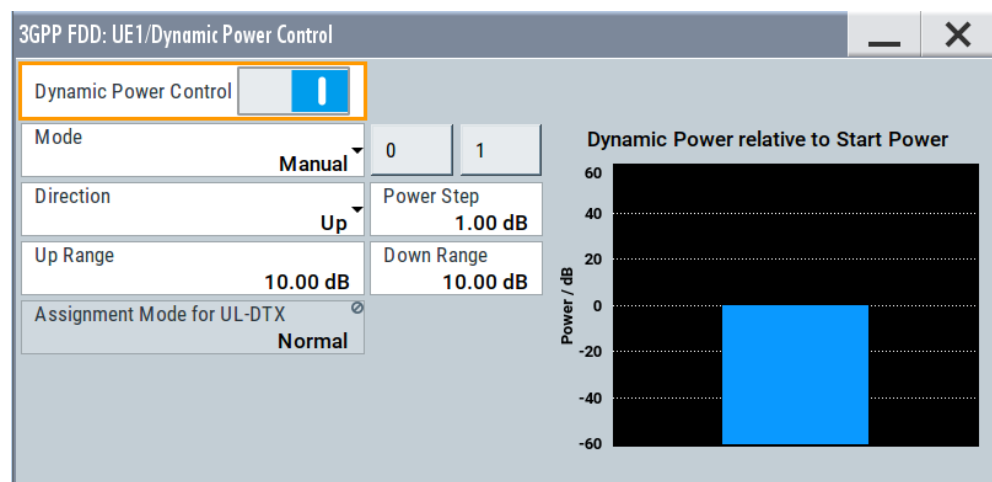

In the "Dynamic Power Control" dialog, the power of the enhanced channels can be changed within the predefined dynamic range. The dynamic range is set as the sum of the parameters "Up Range" and "Down Range". The power is varied with the predefined step size ("Power Step") and with an external, internal or manual control signal.

#### Dynamic Power Control State

Activates or deactivates the "Dynamic Power Control".

With activated "Dynamic Power Control", the power of the enhanced channels can be increased or decreased within the predefined dynamic range. The dynamic range is set as the sum of the parameters "Up Range" and "Down Range".

The power is varied with the predefined step size ("Power Step") and with an internal or manual control signal.

Remote command:

`[ :SOURCE<hw> ] :BB:W3GPP:MSTation [ :ENHanced:DPDCh ] :DPControl:STATE`  
on page 430

#### Mode

Selects the control signal for "Dynamic Power Control".

"By TPC Pattern"

The TPC pattern is used for "Dynamic Power Control". This selection corresponds to selection "(Mis) Use TPC" for not enhanced channels.

"Manual"

The control signal is manually produced by pushing one of the buttons 0 or 1.

The channel power is increased or decreased depending on the "Direction" setting by the set power step.

Remote command:

`[ :SOURCE<hw> ] :BB:W3GPP:MSTation [ :ENHanced:DPDCh ] :DPControl:MODE`  
on page 429

`[ :SOURCE<hw> ] :BB:W3GPP:MSTation [ :ENHanced:DPDCh ] :DPControl:STEP:MANual`  
on page 430

#### Direction

Selects the Dynamic Power Control mode.

"Up"

A high level of the control signal leads to an increase of channel power.

"Down"

A high level of the control signal leads to a decrease of channel power.

Remote command:

`[ :SOURCE<hw> ] :BB:W3GPP:MSTation [ :ENHanced:DPDCh ] :DPControl:DIRection`  
on page 428

#### Power Step

If "Dynamic Power Control > On", sets the step width by which the channel powers of the enhanced channels in the timeslot grid are changed within the set dynamic range. The dynamic range is set as the sum of "Up Range" and "Down Range".

The start power of the channel is set in the "Channel Power" entry field of the menu.

Remote command:

```
[ :SOURce<hw> ] :BB:W3GPp:MSTation [ :ENHanced:DPDCh ] :DPControl :
STEP [ :EXternal ] on page 430
```

### Up Range / Down Range

Sets dynamic range by which – with "Dynamic Power Control" switched on – the channel powers of the enhanced channels can be increased. The resulting "Dynamic Power Control" dynamic range ("Up Range" + "Down Range") depends on the selected "Power Step" and is as follow:

- For "Power Step" < 1 dB, the dynamic range ("Up Range" + "Down Range") <= 30 dB
- For "Power Step" => 1 dB, the dynamic range ("Up Range" + "Down Range") <= 60 dB

Remote command:

```
[ :SOURce<hw> ] :BB:W3GPp:MSTation [ :ENHanced:DPDCh ] :DPControl :
RANGE:UP on page 429
[ :SOURce<hw> ] :BB:W3GPp:MSTation [ :ENHanced:DPDCh ] :DPControl :
RANGE:DOWN on page 429
```

### Power Control Graph

Indicates the deviation of the channel power (delta POW) from the set power start value of the enhanced channels.

The graph is automatically displayed if "Dynamic Power Control > State > On".

**Note:** Since a realtime update of the window in the timeslot (= 0.667 ms) is not possible for reasons of speed, an update can be performed in a coarser time interval. Fast channel power changes are not displayed but the settled state of the control loop can be recognized easily.

Remote command:

```
[ :SOURce<hw> ] :BB:W3GPp:MSTation [ :ENHanced:DPDCh ] :DPControl [ :
POWER ] ? on page 429
```

### Assignment Mode for UL-DTX

The parameter is enabled only for activated [UL-DTX... / User Scheduling State](#).

The power control recognizes the UL-DPCCH gaps according to 3GPP TS 25.214. Some of the TPC commands sent to the instrument over the external line or by the TPC pattern are ignored, whereas others are summed up and applied later. The processing of the TPC commands depends only on whether the BS sends the TPC bits on the F-DPCH with slot format 0/ slot format 9 or not. It is not necessary to distinguish between the cases „DL-DPCH“ and „F-DPCH Slot format different than 9 and 0“. In both of these cases, the downlink TPC commands are sent (to a real UE via the air interface) later than in the first 512 chips of the downlink slot. Thus, the treatment of the TPC commands by the UE is identical.

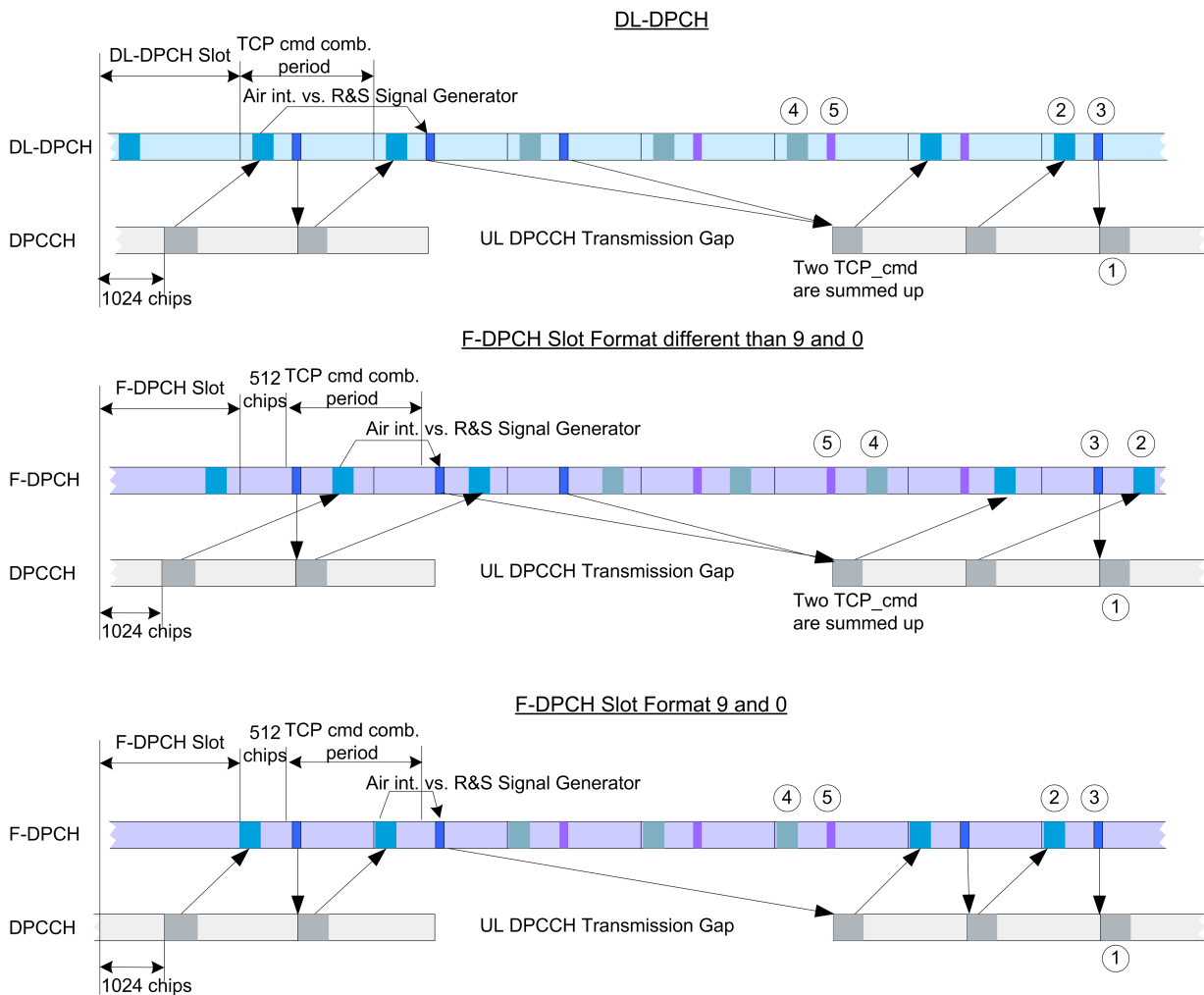

**Figure 3-14: Timing diagram - Power Control with UL-DTX**

- 1 = Uplink pilot
- 2 = TPC bits via air interface
- 3 = TPC command via binary feedback
- 4 = No need to send TPC bits via air interface; UE ignores any TPC bits
- 5 = No need to send TPC commands via binary feedback line; R&S SMBV100B ignores any TPC commands

The feedback sent to the instrument corresponds to the parameter „TPC\_cmd“ defined in the 3GPP standard. It represents the TPC information of the last (already completed) „TPC command combining period“. This is true even if the TPC information of the ongoing „TPC command combining period“ is already known by the BS before the feedback transmission over the binary feedback line.

**Note:** The provided external binary feedback has to be stable at least between 0.1 ms before and after the UL DPCCH slot boundary.

Remote command:

```
[ :SOURCE<hw> ] :BB:W3GPP:MStation [ :ENHanced:DPDCh ] :DPControl:
ASSignment on page 428
```



### 3.27 Scheduling list

Opens a display of the current uplink scheduling per UE.

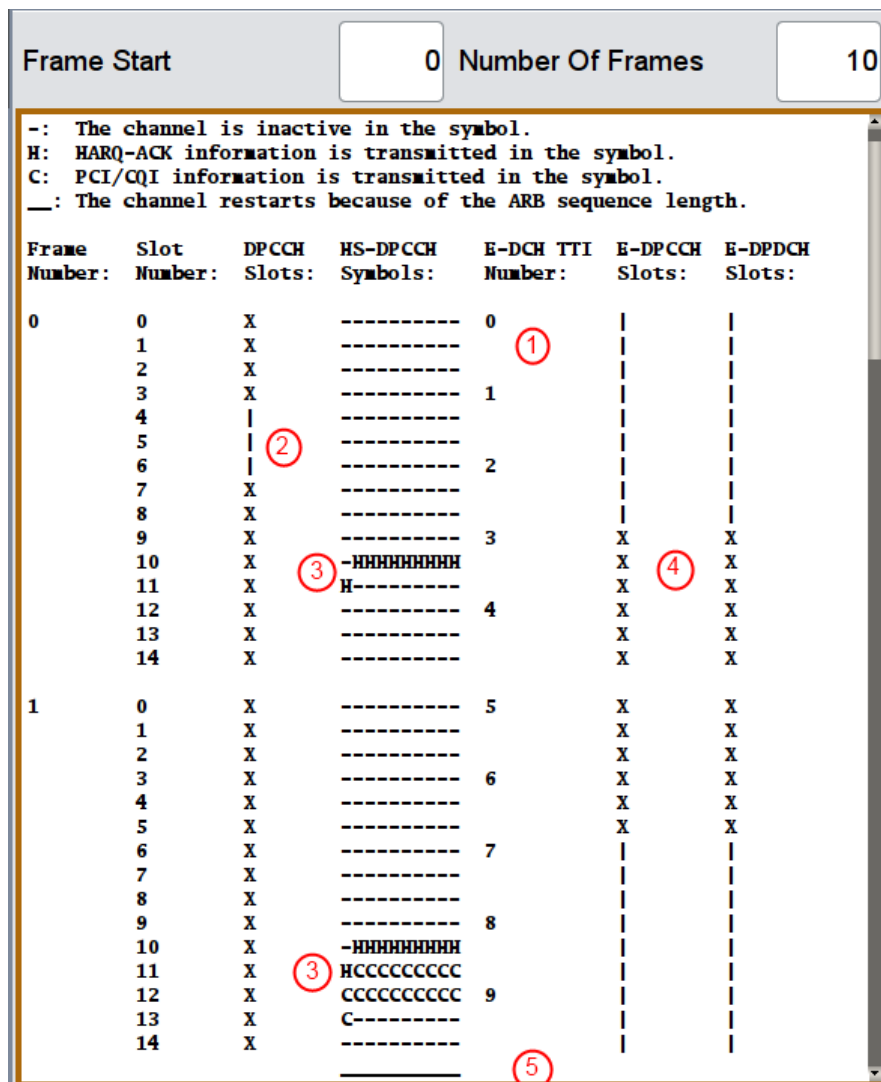

Figure 3-15: Example of Scheduling List (UE1)

- 1 = E-DCH TTI is three slots long, i.e. E-DCH TTI = 2ms
- 2 = DPCCH shows busts pattern, i.e. UL-DTX is activated
- 3 = HS-DPCCH is active and the scheduled HARQ-ACK and PCI/CQI messages have different patterns
- 4 = E-DPCCH and E-DPDCH are active; both channels have the same E-DCH scheduling
- 5 = ARB Sequence Length = 2 frames

**Frame Start**

Defines the start frame of the displayed UL scheduling.

**Number of Frames**

Defines number of frames for that the UL scheduling is displayed.

## 3.28 DPCCH settings - UE

The "DPCCH" tab provides the parameters for configuring the dedicated physical control channel.

Access:

1. Select "3GPP FDD > Link Direction > Uplink / Reverse"
2. Select "User Equipment > UE > Mode > DPCCH + DPDCH".  
Select "DPCCH".

3GPP FDD A: User Equipment1								
General	Code Domain	DPCCH	DPDCH	HS-DPCCH	E-DPCCH	E-DPDCH	E-DCH	
Pilot		6	TFCI		2	TPC		2
Power	0.00 dB		Channelization Code		Q / 0			
DL-UL Timing Offset	1024 Chips		TFCI		0			
Slot Format #	0		FBI Pattern (bin)		0...			
FBI Mode	Off		Read Out Mode		Continuous			
TPC Mode	2 Bits		TPC Pattern (bin)		0...			
TPC Data Source	Pattern							

The dialog displays the channel structure and the available parameters.

In UE1, the DPCCH is generated in real time (enhanced).

### About the dedicated physical channels

At the physical level, an uplink DPCH consists of the DPDCH (Dedicated Physical Data Channel) and the DPCCH (Dedicated Physical Control Channel). The channel characteristics are defined by the symbol rate.

The DPDCH transports the user data that is fed directly into the data field. The DPCCH carries the control fields (Pilot field; TPC = Transmit Power Control, FBI (Feedback Information) and TFCI = Transport Format Combination Indicator). DPDCH is grouped with DPCCH I/Q code multiplexing in accordance with 3GPP TS 25.211, see diagram below. The generation of an uplink reference measurement channel is described in [Chapter 3.35, "Global enhanced channel settings - UE1"](#), on page 213.

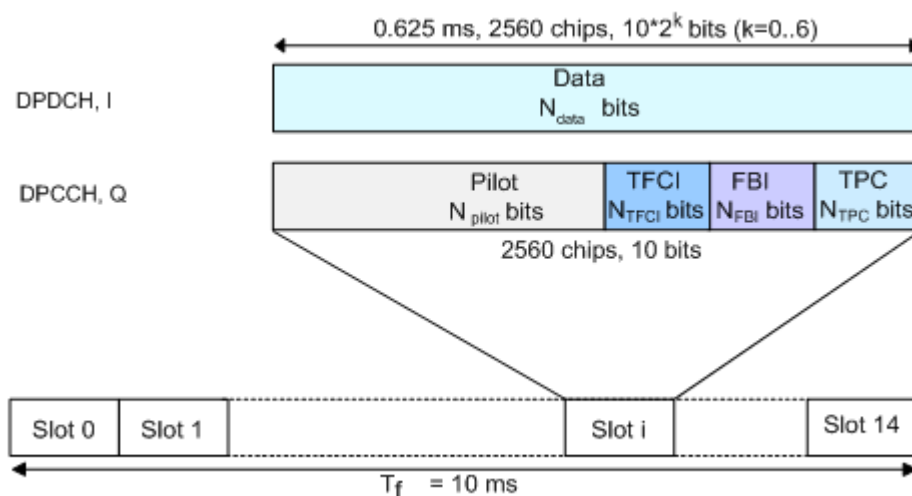

Figure 3-16: Structure of an uplink DPCH in the time domain

### Channelization Code

Displays the channelization code and the modulation branch (I or Q) of the DPCCH. The code channel is spread with the set channelization code (spreading code). The standard assigns a fixed channelization code to the DPCCH.

Remote command:

`[ :SOURCE<hw> ] :BB:W3GPP:MSTation<st>:DPCCh:HS:CCODE?` on page 365

### Power

Sets the power of the DPCCH channel.

Test cases defined in the 3GPP standard often use notation "Signaling values for  $\beta_c$  and  $\beta_d$ ". The quantization of the gain parameters is shown in the following table which is taken from 3GPP TS 25.213 (left columns) and supplemented by the instrument-specific values (right column).

Signaling values for $\beta_c$ and $\beta_d$	Quantized amplitude ratios $\beta_c$ and $\beta_d$	Power to be set / dB
15	1.0	0.0
14	14/15	-0.60
13	13/15	-1.24
12	12/15	-1.94
11	11/15	-2.69
10	10/15	-3.52
9	9/15	-4.44
8	8/15	-5.46
7	7/15	-6.62
6	6/15	-7.96

Signaling values for $\beta_c$ and $\beta_d$	Quantized amplitude ratios $\beta_c$ and $\beta_d$	Power to be set / dB
5	5/15	-9.54
4	4/15	-11.48
3	3/15	-13.99
2	2/15	-17.52
1	1/15	-23.52
0	Switch off	Switch channel off or -80 dB

Remote command:

[\[:SOURCE<hw>\]:BB:W3GPP:MSTation<st>:DPCCh:POWER](#) on page 359

### DL-UL Timing Offset

Sets the timing offset between the downlink and the uplink.

The timing offset determines the time delay in chips between the downlink signal timing and transmission of the uplink signal.

**Note:** The signals of all UEs have the same uplink slot timing. The parameters "DL-UL Timing Offset" are coupled and by changing this parameter for one of the UEs, the values for the other UEs are automatically adjusted.

"1024 Chips" The uplink signal is generated according to the 3GPP specification. The signal is calculated synchronously to the downlink reference timing, i.e. the first uplink frame starts at chip position 1024 of the simulated signal.

"0 Chips" No timing offset is applied, i.e. there is no timing delay between receipt of the downlink signal and transmission of the uplink signal. See also ["To generate a continuous uplink signal composed of multiple separately generated uplink frames"](#) on page 254.

Remote command:

[\[:SOURCE<hw>\]:BB:W3GPP:MSTation<st>:DPCCh:TOFFset](#) on page 361

### Slot Format #

Selects the slot format.

The slot format defines the structure of the DPCCH slots and the control fields. Depending on the selected slot format, the slot structure is displayed.

Slot formats 0 to 4 are available for the DPCCH channel as defined in the 3GPP Rel. 7 specification TS 25.211.

**Note:** The former slot formats 4 and 5 according to 3GPP Rel. 4 specification TS 25.211 are not supported.

The slot format selection adjusts the DPCCH slot structure according to the 3GPP specification. However, it is also possible to adjust this structure by configuration of each of the control fields separately.

The table below gives an overview of the cross-reference between the slot format and the structure of the DPCCH slot.

Slot format #	Pilot, bits	NTPC, bits (TPC Mode)	NTFCI, bits (Use TFCI)	NFBI, bits (FBI Mode)
0	6	2	2	0
1	8	2	0	0
2	5	2	2	1
3	7	2	0	1
4	6	4	0	0

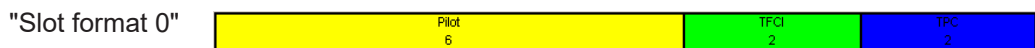

"FBI Mode" = Off, i.e. no FBI field

"TFCI Mode" = 2 bits

"Use TFCI" = On, i.e. TFCI field = 2 bits

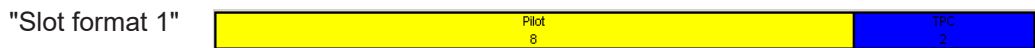

"FBI Mode" = Off, i.e. no FBI field

"TFCI Mode" = 2 bits

"Use TFCI" = Off, i.e. no TFCI field



"FBI Mode" = 1 bit

"TFCI Mode" = 2 bits

"Use TFCI" = On, i.e. TFCI field = 2 bits

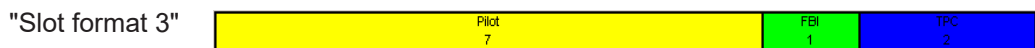

"FBI Mode" = 1 bit

"TFCI Mode" = 2 bits

"Use TFCI" = Off, i.e. no TFCI field



Option: R&S SMBVB-K83

"FBI Mode" = Off, i.e. no FBI field

"TFCI Mode" = 4 bits

"Use TFCI" = Off, i.e. no TFCI field

Remote command:

[\[:SOURCE<hw>\]:BB:W3GPp:MSTation<st>:DPCCh:SFORmat](#) on page 359

### Use TFCI

Activates the TFCI (transport format combination indicator) field.

The status of the TFCI field is determined by the "Slot Format" set. A change leads automatically to an adjustment of the slot format.

Remote command:

[\[:SOURCE<hw>\]:BB:W3GPp:MSTation<st>:DPCCh:TFCI:STATE](#) on page 360

**TFCI**

Enters the value of the TFCI field (transport format combination indicator) of the DPCCH channel.

Remote command:

[\[:SOURCE<hw>\]:BB:W3GPP:MSTation<st>:DPCCh:TFCI](#) on page 360

**FBI Mode**

Selects the FBI (feedback information) mode.

The FBI mode is determined by the "Slot Format" set. A change in the FBI mode leads automatically to an adjustment of the slot format.

**Note:** The former 2-bits long FBI Mode according to 3GPP Rel. 4 specification TS 25.211 is not supported.

"Off"                    The FBI field is not in use.

"1 Bit"                 The FBI field with a length of 1 bit is used.

Remote command:

[\[:SOURCE<hw>\]:BB:W3GPP:MSTation<st>:DPCCh:FBI:MODE](#) on page 358

**FBI Pattern (bin)**

Enters the bit pattern for the FBI field.

The FBI field is filled cyclically with a pattern of up to 32 bits in length.

Remote command:

[\[:SOURCE<hw>\]:BB:W3GPP:MSTation<st>:DPCCh:FBI:PATtern](#) on page 359

**TPC Mode**

Selects the TPC (Transmit Power Control) mode.

The TPC mode is determined by the "Slot Format" set. A change in the TPC mode leads automatically to an adjustment of the slot format.

"2 Bits"                A TPC field with a length of 2 bits is used.

"4 Bits"                Option: R&S SMBVB-K83

A TPC field with a length of 4 bits is used.

A 4 bits long TPC field can be selected, only for Slot Format 4 and disabled FBI and TFCI fields.

Remote command:

[\[:SOURCE<hw>\]:BB:W3GPP:MSTation<st>:DPCCh:TPC:MODE](#) on page 363

**TPC Data Source**

Defines the data source for the TPC field of the DPCCH channel.

The following standard data sources are available:

- "All 0, All 1"  
An internally generated sequence containing 0 data or 1 data.
- "Pattern"  
An internally generated sequence according to a bit pattern.  
Use the "Pattern" box to define the bit pattern.
- "Data List / Select TPC Data List"  
A binary data from a data list, internally or externally generated.  
Select "Select TPC Data List" to access the standard "Select List" dialog.

- Select the "Select Data List > navigate to the list file \*.dm\_iqd > Select" to select an existing data list.
- Use the standard "File Manager" function to transfer external data lists to the instrument.
- Use the "New" and "Edit" functions to create internally new data list or to edit an existing one.

See also:

- Section "Modulation Data" in the R&S SMBV100B user manual.
- Section "File and Data Management" in the R&S SMBV100B user manual.
- Section "Data List Editor" in the R&S SMBV100B user manual.

Remote command:

`[ :SOURce<hw> ] :BB:W3GPp:MSTation<st>:DPCCh:TPC:DATA` on page 361

`[ :SOURce<hw> ] :BB:W3GPp:MSTation<st>:DPCCh:TPC:DATA:PATtern`  
on page 362

`[ :SOURce<hw> ] :BB:W3GPp:MSTation<st>:DPCCh:TPC:DATA:DSElect`  
on page 361

### TPC Read Out Mode

Defines TPC data usage.

The TPC bits are used to signal the increase or reduction in transmit power to the called station. For all read out modes, 1 bit is taken from the data stream for the TPC field for each slot. The bit is entered into the bitstream several times, depending on the symbol rate. The difference between the modes lies in the usage of the TPC bits.

The different modes can be used to set a specific output power and then let the power oscillate around this value. For example, if the power is the pattern 11111, the power can be varied with "Single + alt. 01" and "Single + alt. 10". Thus, power measurements can be carried out at quasi-constant power.

- "Continuous:"  
The TPC bits are used cyclically.
- "Single + All 0"  
The TPC bits are used once, and then the TPC sequence is continued with 0 bits.
- "Single + All 1"  
The TPC bits are used once, and then the TPC sequence is continued with 1 bit.
- "Single + alt. 01"  
The TPC bits are used once and then the TPC sequence is continued with 0 bits and 1 bit alternately. Bits as appended in multiples, depending on the symbol rate, for example, 00001111.
- "Single + alt. 10"  
The TPC bits are used once and then the TPC sequence is continued with 1 bit and 0 bits alternately. Bits as appended in multiples, depending on by the symbol rate, for example, 11110000.

Use the parameter "Read Out Mode" together with the option "TPC For Output Power Control (Mis-) Use" to generate various output power profiles.

Remote command:

`[ :SOURce<hw> ] :BB:W3GPp:MSTation<st>:DPCCh:TPC:READ` on page 364

### Misuse TPC for Output Power Control

(available for UE2, UE3 and UE4 only)

Defines "mis-" use of the TPC data.

The TPC bits are used to signal the increase or reduction in transmit power to the called station.

If "(Mis-) use TPC for output power control" is activated, the specified pattern is used to vary the intrinsic transmit power over time. A bit of this pattern is removed for each slot in order to increase (bit = "1") or reduce (bit = "0") the channel power by the specified power step ("Power Step"). The upper limit is 0 dB and the lower limit -60 dB.

The following envelope is produced with the settings:

- Channel power = 0 dB
- Power step = 1.0 dB
- Pattern = "0011110100000011"
- "TPC Read Out Mode = Continuous"

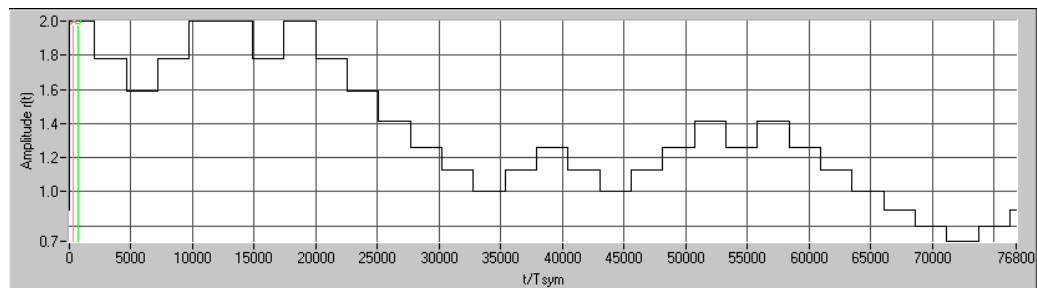

**Figure 3-17: Dynamic change of channel power (continuous)**

**Note:** Power control works both on the DPCCH and all the active DPDCHs. The change in power is always carried out (as stipulated in the standard) at the start of the slot pilot field

Remote command:

[\[:SOURCE<hw>\]:BB:W3GPP:MSTation<st>:DPCCh:TPC:MISSuse](#) on page 362

### TPC Power Step

(available for UE2, UE3 and UE4 only)

Sets the step width of the power change in dB for "(Mis-) use TPC for output power control".

Remote command:

[\[:SOURCE<hw>\]:BB:W3GPP:MSTation<st>:DPCCh:TPC:PSTep](#) on page 363

## 3.29 DPDCH settings - UE

Access:

1. Select "3GPP FDD > Link Direction > Uplink / Reverse > User Equipments > UE"



2. Select "DPDCH".

3GPP FDD A: User Equipment1

General Code Domain DPCCCH **DPDCH** HS-DPCCH E-DPCCH E-DPDCH E-DCH

Data 40

State  Channel Power 0.00 dB

Overall Symbol Rate 60 ksps Force Channelization Code To I / 0

Global Enhanced Channels ...

	1	2	3	4	5	6
Channel Type	DPDCH	DPDCH	DPDCH	DPDCH	DPDCH	DPDCH
Symbol Rate / State	60	off	off	off	off	off
Channelization Code	I / 16					
DPDCH Data Source	PN 9					
DPDCH Pattern	0					

The dialog contains the general parameters required for configuring the channel. The channel table allows you to configure the individual parameters.

### 3.29.1 DPDCH common settings

#### State (DPDCH)

Activates or deactivates all the DPDCH channels.

Remote command:

`[ :SOURce<hw> ] :BB:W3GPP:MSTation<st>:DPDCh:STATe` on page 385

#### Channel Power

Sets the channel power in dB.

The power entered is relative to the powers of the other channels and does not initially relate to the "Level" power display. If [Adjust Total Power To 0 dB](#) is executed, all the power data is relative to "Level".

**Note:** The uplink channels are not blanked in this mode (duty cycle 100%).

Test cases defined in the 3GPP standard often use notation "Signaling values for  $\beta_c$  and  $\beta_d$ ". The quantization of the gain parameters is shown in the following table which is taken from 3GPP Spec 25.213 (left columns) and supplemented by the instrument-specific values (right column).

Signaling values for $\beta_c$ and $\beta_d$	Quantized amplitude ratios $\beta_c$ and $\beta_d$	Power to be set / dB
15	1.0	0.0
14	14/15	-0.60
13	13/15	-1.24

Signaling values for $\beta_c$ and $\beta_d$	Quantized amplitude ratios $\beta_c$ and $\beta_d$	Power to be set / dB
12	12/15	-1.94
11	11/15	-2.69
10	10/15	-3.52
9	9/15	-4.44
8	8/15	-5.46
7	7/15	-6.62
6	6/15	-7.96
5	5/15	-9.54
4	4/15	-11.48
3	3/15	-13.99
2	2/15	-17.52
1	1/15	-23.52
0	Switch off	Switch channel off or -80 dB

Remote command:

[\[:SOURCE<hw>\]:BB:W3GPP:MSTation<st>:DPDCh:POWer](#) on page 385

#### Force Channelization Code To I/Q

Sets the channelization code to I/Q.

This mode can only be activated if the "Overall Symbol Rate < 2 x 960 kbps".

It is provided for test purposes. Using an oscilloscope, the data bits of the DPDCH are visible on the I/Q signal for the following settings:

- "Force Channelization Code to I/Q > On"
- "Scrambling Code Mode > Off"
- "DPCCH Channel Power = - 80 dB"

Remote command:

[\[:SOURCE<hw>\]:BB:W3GPP:MSTation<st>:DPDCh:FCIO](#) on page 384

#### Overall Symbol Rate

Sets the overall symbol rate of all the DPDCH channels.

The structure of the DPDCH channel table depends on this parameter. The overall symbol rate determines which DPDCHs are active, which symbol rate they have and which channelization codes they use (see [Table A-2](#)).

DPDCHs that are not active by virtue of the overall rate are also disabled for operation.

**Note:** Up to an overall rate of 960 ksps, only DPDCH 1 is active, its symbol rate is the same as the overall symbol rate and the channelization code is the same as spreading factor/4 (spreading factor = chip rate / symbol rate).

With an overall symbol rate greater than 960 ksps, all the active DPDCH channels have the symbol rate 960 ksps.

Remote command:

[ :SOURce<hw> ] :BB:W3GPp:MSTation<st>:DPDCh:ORATe on page 385

### Global Enhanced Channels

Accesses the dialog for configuring all the enhanced channel settings of user equipment UE1, see [Chapter 3.35, "Global enhanced channel settings - UE1"](#), on page 213.

Remote command:

n.a.

## 3.29.2 Channel table

The channel table allows you to configure the individual parameters for the DPDCH channels. The structure of the currently selected channel is displayed graphically in the table header.

The number of active channels depends on the selected overall symbol rate. You can select the data sources for the individual channels. The remaining parameters are only displayed and their values depend also on the overall symbol rate. See also [Table A-2](#).

### Channel Number

Displays the channel number.

Remote command:

n.a.

(the channel is selected by the suffix at keyword CHANnel<n>)

### Channel Type

Displays the channel type.

Remote command:

n.a.

### Symbol Rate / State

Displays the symbol rate and the state of the DCDCH channel.

The symbol rate and the state of channel 2 to 6 are dependent on the overall symbol rate set and cannot be modified.

Remote command:

[ :SOURce<hw> ] :BB:W3GPp:MSTation<st>:CHANnel<ch>:DPDCh:SRATe?  
on page 384

### Channelization Code

Displays the channelization code and the modulation branch (I or Q) of the DPDCH channel.

The channelization code is dependent on the overall symbol rate set and cannot be modified.

Remote command:

[ :SOURce<hw> ] :BB:W3GPp:MSTation<st>:CHANnel<ch>:DPDCh:CCODE?  
on page 382

**DPDCH Data Source**

For UE2, UE3 and UE4 and UE1 without channel coding, selects the data source for the DPDCH channel.

When channel coding is active, the data source for the DTCH1 component in the transport layer is selected here. In this situation, the display reads "DTCH data Source" and the "DCCH Data" entry field is enabled for selecting the data source of the DCCH channel. The data sources of the other DTCH channels can be set in the "Global Enhanced Channel Settings > Transport Channel" dialog, see [Chapter 3.35, "Global enhanced channel settings - UE1"](#), on page 213.

The following standard data sources are available:

- "All 0, All 1"  
An internally generated sequence containing 0 data or 1 data.
- "PNxx"  
An internally generated pseudo-random noise sequence.
- "Pattern"  
An internally generated sequence according to a bit pattern.  
Use the "Pattern" box to define the bit pattern.
- "Data List/Select DList"  
A binary data from a data list, internally or externally generated.  
Select "Select DList" to access the standard "Select List" dialog.
  - Select the "Select Data List > navigate to the list file \*.dm\_iqd > Select" to select an existing data list.
  - Use the "New" and "Edit" functions to create internally new data list or to edit an existing one.
  - Use the standard "File Manager" function to transfer external data lists to the instrument.

See also:

- Section "Modulation Data" in the R&S SMBV100B user manual.
- Section "File and Data Management" in the R&S SMBV100B user manual.
- Section "Data List Editor" in the R&S SMBV100B user manual

Remote command:

`[ :SOURce<hw> ] :BB:W3GPp:MSTation<st>:CHANnel<ch>:DPDCh:DATA`  
on page 382

`[ :SOURce<hw> ] :BB:W3GPp:MSTation<st>:CHANnel<ch>:DPDCh:DATA: PATTern` on page 384

`[ :SOURce<hw> ] :BB:W3GPp:MSTation<st>[:HSUPa]:CHANnel<ch>:DPDCh:E: DATA:DSElect` on page 408

**DCCH Data Source**

For UE1 for enhanced channels with active channel coding, selects the data source for the DCCH component.

The following standard data sources are available:

- "All 0, All 1"  
An internally generated sequence containing 0 data or 1 data.
- "PNxx"  
An internally generated pseudo-random noise sequence.
- "Pattern"  
An internally generated sequence according to a bit pattern.

Use the "Pattern" box to define the bit pattern.

- "Data List/Select DList"

A binary data from a data list, internally or externally generated.

Select "Select DList" to access the standard "Select List" dialog.

- Select the "Select Data List > navigate to the list file \*.dm\_iqd > Select" to select an existing data list.
- Use the "New" and "Edit" functions to create internally new data list or to edit an existing one.
- Use the standard "File Manager" function to transfer external data lists to the instrument.

See also:

- Section "Modulation Data" in the R&S SMBV100B user manual.
- Section "File and Data Management" in the R&S SMBV100B user manual.
- Section "Data List Editor" in the R&S SMBV100B user manual

### 3.30 HS-DPCCH settings - UE

Access:

1. Select "3GPP FDD > Link Direction > Uplink / Reverse > User Equipments > UE".
2. Select "HS-DPCCH".

HARQ-ACK (Slots) 1		PCI / CQI (Slots) 2	
State	<input checked="" type="checkbox"/>	Power	0.00 dB
Compatibility Mode	Release 8 and Later		
Start Delay	101 * 256 Chips	MIMO Mode	<input checked="" type="checkbox"/>
Inter TTI Distance (Interval)	5 Subframes	Secondary Cell Enabled	1
Channelization Code	Q / 64	Secondary Cell Active	0
Slot Format	0 (15ksps)		

3GPP FDD: User Equipment1

General Code Domain DPCCH DPDCH **HS-DPCCH** E-DPCCH E-DPDCH E-DCH

**HARQ - ACK**

Number of Rows: 2 HARQ-ACK Repeat After: 4 Intervals

	HARQ-ACK From Interval	HARQ-ACK To Interval	HS-DPCCH 1 HARQ-ACK 1	HS-DPCCH 1 HARQ-ACK 2	HS-DPCCH 2 HARQ-ACK 3	HS-DPCCH 2 HARQ-ACK 4	Pow Offs /dB
0	0	0	1 AA/D				0.0
1	0	3	3 NN/NN				0.0

**PCI / CQI**

Number of Rows: 2 PCI/CQI Repeat After: 4 Intervals

	PCI/CQI From	PCI/CQI To	HS-DPCCH PCI/CQI1 Type	PCI/CQI Content	HS-DPCCH PCI/CQI2 Type	PCI/CQI Content	HS-DPCCH PCI/CQI3 Type	PCI/CQI Content	HS-DPCCH PCI/CQI4 Type	PCI/CQI Content	Pow Offs /dB
0	0	0	DTX								
1	0	1	DTX								

The dialog contains the general parameters required for configuring the channel, and displays the channel structure.



### Realtime signal generation

To enable realtime signal generation for UE1:

- Select "3GPP FDD > User Equipment > UE1> HS-DPCCH"
- Select "Compatibility Mode > Up to Release 7"

## 3.30.1 About HS-DPCCH

### HS-DPCCH Structure

The HS-DPCCH carries uplink feedback signaling related to the accuracy and quality of downlink HS-DSCH transmission. Hybrid-ARQ Acknowledgment (HARQ-ACK) is transmitted in the first subframe slot. Channel quality Indication (CQI) and if UE configured in MIMO mode, also precoding control indication (PCI) are transmitted in the second and third subframe slot. Only one HS-DPCCH can be transmitted on each radio link. The HS-DPCCH can only exist together with an uplink DPCCH.

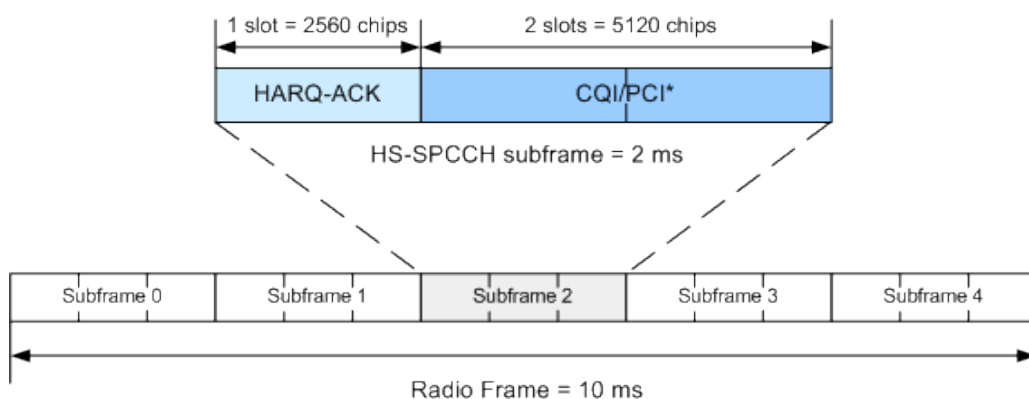

\*) PCI for UE configured in MIMO mode only

Figure 3-18: Structure of an uplink HS-DPCCH in the time domain

The HS-DPCCH subframe starts  $256 \times m$  chips after the start of an uplink DPCCH slot. The value  $m$  is selected such that the subframe transmission starts within the first 0 to 255 chips after 7.5 slots following the end of the received HS-PDSCH subframe.

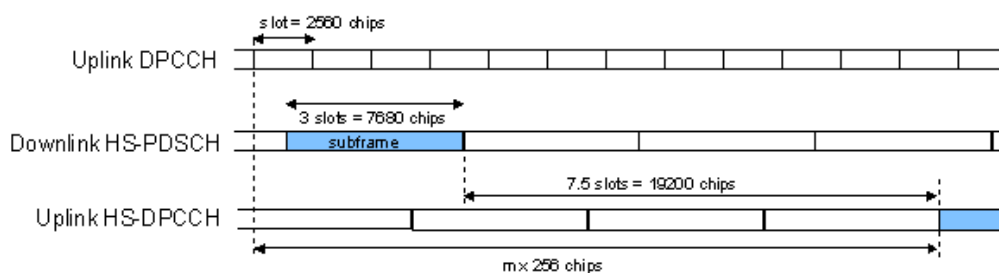

Figure 3-19: Timing offset between the uplink DPCCH, the HS-PDSCH and the HS-DPCCH at the UE

### HS-DPCCH Power

According to 3GPP TS 25.214, the uplink HS-DPCCH power is estimated for each HS-DPCCH slot.

In this implementation, the channel power can be set individually for each case of feedback signaling and UE mode. The channel power is set as a combination of the CQI Power (parameter "Power") and the corresponding "Power Offset" (see Table 3-8 and Table 3-9). Since the feedback signaling can be configured per slot of TTI that carries HS-DPCCH, the channel power is also calculated on a slot basis.

Table 3-8: Calculating of the HARQ-ACK power

Mode	HARQ-ACK	Offset parameter	Resulting power
Compatibility Mode = Up to Release 7			
Normal	ACK/NACK pattern	Power Offset ACK	Power + Power Offset ACK
		Power Offset NACK	Power + Power Offset NACK
	Single ACK	Power Offset ACK	Power + Power Offset ACK

Mode	HARQ-ACK	Offset parameter	Resulting power
	Single NACK	Power Offset NACK	Power + Power Offset NACK
MIMO	TB1: ACK, TB2: ACK	Power Offset ACK/ACK	Power + Power Offset ACK/ACK
	TB1: ACK, TB2: NACK	Power Offset ACK/NACK	Power + Power Offset ACK/NACK
	TB1: NACK, TB2: ACK	Power Offset NACK/ACK	Power + Power Offset NACK/ACK
	TB1: NACK, TB2: NACK	Power Offset NACK/NACK	Power + Power Offset NACK/ NACK
<b>Compatibility Mode = Release 8 and later</b>			
all	HARQ-ACK	Power Offset HARQ-ACK	Power + Power Offset HARQ-ACK

Table 3-9: Calculating the PCI/CQI power

Mode	CQI	Type	CQI parameter	Offset parameter	Resulting power
<b>Compatibility. Up to Release 7 Mode=</b>					
Normal	-		CQI	-	Power
MIMO	CQI Type A	Single TB	CQIs	Power Offset CQI Type A	Power + Power Offset CQI Type A
		Double TB	CQI1 and CQI2		
<b>Compatibility. Rel. 8 and later Mode=</b>					
Normal	CQI		CQI	Power Offset PCI/CQI	Power + Power Offset PCI/CQI
DC-HSDPA non-MIMO	Comp. CQI		CQI1 and CQI2		
MIMO	CQI Type A	Single TB	CQIs		
		Double TB	CQI1 and CQI2		

### 3.30.2 HS-DPCCH common settings

The displayed channel structure depends on whether the UE is working in MIMO mode or not.

#### State (HS-DPCCH)

Activates or deactivates the HS-DPCCH channel.

Remote command:

[\[:SOURCE<hw>\]:BB:W3GPP:MSTation<st>:DPCCh:HS:STATE](#) on page 364



**Power (HS-DPCCH)**

Sets the power in dB.

- In a "Compatibility Mode > Release 8 and Later" mode, this parameter represents the **reference power** used to calculate:
  - The power used during the HARQ-ACK slot
  - The power used during the PCI/CQI slots
- In a "Compatibility Mode > Up to Release 7" mode, this parameter represents the **CQI power of a UE** that:
  - Is configured in a normal mode
  - Is configured in MIMO mode and sending CQI Type B report.

The CQI Power is the reference power used to calculate:

- The power used during the HARQ-ACK slot
- The power used during the PCI/CQI slots of a UE configured in MIMO mode and sending CQI Type A reports.

The power entered is relative to the powers of the other channels and does not initially relate to the "Level" power display. If [Adjust Total Power To 0 dB](#) is executed, all the power data is relative to the "Level" display.

Remote command:

[\[:SOURCE<hw>\]:BB:W3GPP:MSTation<st>:DPCCh:HS:POWER](#) on page 365

**Compatibility Mode (HS-DPCCH)**

Switches between the following modes:

"Up to Release 7"

Switches to the display of the HS-DPCCH settings provided for backwards compatibility.

"Release 8 and Later"

The concept of the graphical user interface for the configuration of HS-DPCCH has been adapted to support simultaneous DC-HSDPA and MIMO operation, as required in 3GPP Release 9 onwards.

This mode is disabled, if [Dynamic Power Control State](#) is On.

"Release 8 and Later RT"

Enables generation of the HS-DPCCH in real-time even for Release 8/9 content. Real-time signals are useful for complex HS-DPCCH scheduling and are required while using dynamic power control with the HS-DPCCH.

Remote command:

[\[:SOURCE<hw>\]:BB:W3GPP:MSTation<st>:DPCCh:HS:COMPATIBILITY](#) on page 365

**Start Delay**

Sets the delay between the uplink HS-DPCCH and the frame of uplink DPCH.

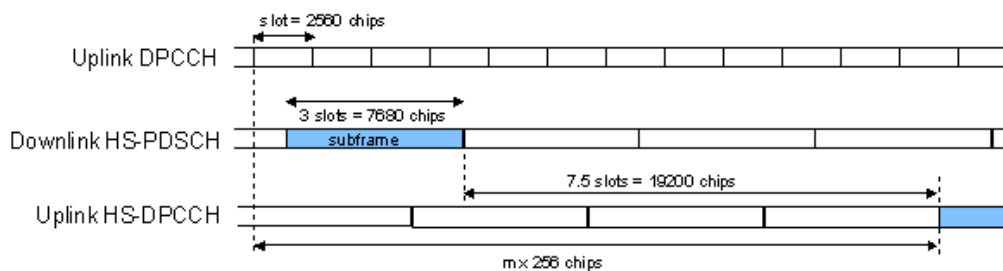

Thus, the channel can be synchronized with the associated downlink HS-PDSCH.

The delay is entered as a multiple  $m$  of 256 chips according to TS 25.211 7.7:

$$m = (T_{TX\_diff} / 256) + 101$$

Where  $T_{TX\_diff}$  is the difference in chips ( $T_{TX\_diff} = 0, 256, \dots, 38144$ ).

The value range of  $m$  is 0 to 250 (2 frames + 1024 chips)

Remote command:

`[ :SOURCE<hw> ] :BB:W3GPp:MSTation<st>:DPCCh:HS:SDELay` on page 366

#### Inter TTI Distance (Interval)

Selects the distance between two HSDPA packets. The distance is set in number of subframes (3 slots = 2 ms). An "Inter TTI Distance" of 1 means continuous generation.

Regarding the HS-DPCCH uplink transmission, this parameter determines where HS-DPCCH transmissions are possible in principle.

To have actual HS-DPCCH transmissions, HARQ-ACK and/or PCI/CQI transmissions have to be scheduled as described in:

- [3.30.3](#)
- [3.30.4](#)
- [3.30.5](#)

Remote command:

`[ :SOURCE<hw> ] :BB:W3GPp:MSTation<st>:DPCCh:HS:TTIDistance`  
on page 366

#### Channelization Code (HS-DPCCH)

Displays the channelization code and the modulation branch (I or Q) of the HS-DPCCH.

The code channel is spread with the set channelization code (spreading code). The channelization code of the high-speed channel depends on the number of activated DPDCHs, i.e. on the overall symbol rate.

For "Secondary Cell Enabled  $\geq 4$ ", two HS-DPCCHs, i.e. two channelization codes are used.

**Example:**

Enable the following settings:

- "DPDCH State = On"
- "DPDCH Overall Symbol Rate = 60 ksp/s"
- "HS-DPCCH State = On"
- "Secondary Cell Enabled = 0"

The used channelization code is "HS-DPCCH > Channelization Code = Q / 64".

Open the "User Equipment > Code Domain" dialog (see Figure 3-20).

- Enable "Secondary Cell Enabled = 4"



**Figure 3-20: Impact of "Secondary Cell Enabled  $\geq$  4" on the used channelization code**

- 1 = The display confirms, that the DPDCH uses a 60 ksp/s symbol rate and a channelization code on the I channel. The HS-DPCCH is displayed with a symbol rate of 15 ksp/s (i.e "Slot Format 0") on the Q channel.
- 2 = The "Code Domain" dialog displays the two HS-DPCCHs, one on each of the I and Q channels. The used symbol rate is 30 ksp/s, i.e the "Slot Format 1" is used.

Remote command:

`[ :SOURce<hw> ] :BB:W3Gpp:MSTation<st>:DPCCh:HS:CCODE?` on page 365

**Slot Format**

Displays the used slot format.

The specified slot format for "Secondary Cell Enabled < 2" is "Slot Format 0 (15 ksps)". With more than 2 secondary cells or with 2 secondary cells and "MIMO Mode = On", the "Slot Format 1 (30 ksps)" is required, i.e. slot format with higher symbol rate.

See also [Figure 3-20](#).

Remote command:

[ :SOURce<hw> ] :BB:W3GPP:MSTation<st>:DPCCh:HS:SFormat? on page 376

### 3.30.3 HS-DPCCH scheduling table (Release 8 and later/RT)



These settings are available for "Compatibility Mode > Release 8 and Later".

Option: R&S SMBVB-K83 for MIMO settings and DC-HSDPA/4C-HSDPA/8C-HSDPA.

With the provided settings, you can adjust the HS-DPCCH signal of a UE configured for one of the following operations: normal operation, DC-HSDPA or 4C/8C-HSDPA operation, MIMO mode or for a simultaneous secondary cell + MIMO operation.

The HS-DPCCH structure can be configured with the parameters "Inter TTI Distance", "Number of Table Rows", "From/To" and "Repeat After". The HARQ-ACK and CQI/PCI information can be configured with the parameters of the HS-DPCCH scheduling tables. The scheduling for the HARQ-ACK and PCI/CQI reports can be performed independently; different repetition cycles can be specified.

#### Example: HS-DPCCH scheduling

The following is a simple example intended to explain the principle. Configured is an HS-DPCCH scheduling in "MIMO Mode = Off" and with "Secondary Cell Enabled = 0".

Parameter	Value
Start Delay	101 * 256 Chips
Compatibility Mode (HS-DPCCH)	Release 8 and later (RT)
Inter TTI Distance (Interval)	5 Subframes
HARQ-ACK scheduling	
Number of Rows	2
HARQ-ACK Repeat After	4 intervals
Row#0	
HARQ-ACK From Interval/ HARQ-ACK To Interval	from HARQ-ACK interval 0 to 1
HS-DPCCH 1/2, HARQ-ACK 1/2/3/4	A
Row#1	
HARQ-ACK From Interval/ HARQ-ACK To Interval	from HARQ-ACK interval 3 to 3
HS-DPCCH 1/2, HARQ-ACK 1/2/3/4	N
PCI/CQI scheduling	

Parameter	Value
Number of Rows	2
PCI/CQI Repeat After	3 intervals
Row#0	
PCI-CQI From Interval/ PCI-CQI To Interval	from PCI/CQI interval 0 to 0
HS-DPCCH 1/2, PCI/CQI 1/2/3/4 Type	DTX
Row#1	
PCI-CQI From Interval/ PCI-CQI To Interval	from PCI/CQI interval 1 to 1
HS-DPCCH 1/2, PCI/CQI 1/2/3/4 Type	CQI
CQI/CQI <sub>5</sub> /CQI <sub>1</sub> /CQI <sub>2</sub>	5



Use the [Scheduling list](#) to display the configured scheduling.

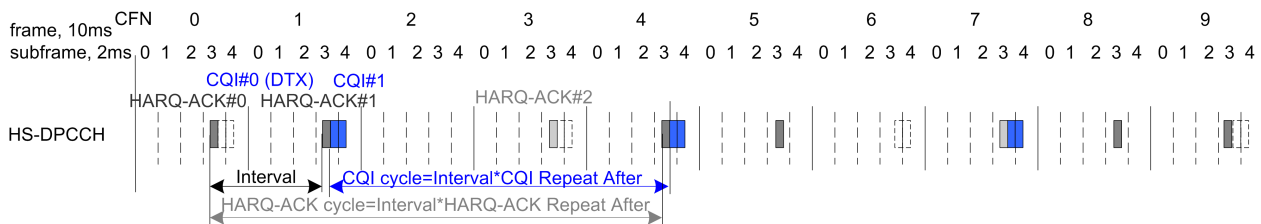

**Figure 3-21: Example of HS-DPCCH Scheduling**

"Inter TTI Distance (Interval)" = Five subframes

"HARQ-ACK Cycle" = "Inter TTI Distance (Interval)" \* "HARQ-ACK Repeat After" = 5 \* 4 = 20 Intervals"

"CQI Cycle" = "Inter TTI Distance (Interval)" \* "CQI Repeat After" = 5 \* 3 = 15 Intervals"

### MIMO Mode

Enables/disables working in MIMO mode for the selected UE.

Remote command:

`[ :SOURCE<hw> ] :BB:W3GPp:MSTation<st>:DPCCh:HS:MMODE` on page 376

### Secondary Cell Enabled

Enables the selected number of secondary cells for the selected UE. Secondary cells are used for working in DC-/4C/8C-HSDPA mode.

See also [Chapter 2.3.15, "Dual cell HSDPA \(DC-HSDPA\)"](#), on page 36, [Chapter 2.3.16, "HS-DPCCH extension for 4C-HSDPA and 8C-HSDPA"](#), on page 40 and [Chapter 4.4, "How to configure the HS-DPCCH settings for 4C-HSDPA tests"](#), on page 256.

Remote command:

`[ :SOURCE<hw> ] :BB:W3GPp:MSTation<st>:DPCCh:HS:SC:ENABLEd` on page 376

**Secondary Cell Active**

Sets the number of active secondary cells for the selected UE.

See also [Chapter 2.3.15, "Dual cell HSDPA \(DC-HSDPA\)"](#), on page 36, [Chapter 2.3.16, "HS-DPCCH extension for 4C-HSDPA and 8C-HSDPA"](#), on page 40 and [Chapter 4.4, "How to configure the HS-DPCCH settings for 4C-HSDPA tests"](#), on page 256.

Remote command:

`[ :SOURCE<hw> ] :BB:W3GPP:MSTation<st>:DPCCh:HS:SC:ACTIVE` on page 376

**HARQ-ACK**

Comprises the parameters provided for the independent configuration of the HARQ-ACK scheduling.

**Number of Rows ← HARQ-ACK**

Determines the number of the rows in the HARQ-ACK scheduling table.

Each row represents one TTI interval, as configured with the parameter [Inter TTI Distance \(Interval\)](#). The parameters set in the table are read out cyclically.

See also [Figure 3-21](#).

Remote command:

`[ :SOURCE<hw> ] :BB:W3GPP:MSTation<st>:DPCCh:HS:HACK:ROWS` on page 377

**HARQ-ACK Repeat After ← HARQ-ACK**

Defines the cycle length after that the information in the HS-DPCCH scheduling table is read out again from the beginning.

The parameter together with the parameter [Inter TTI Distance \(Interval\)](#) defines the repetition cycle of the HARQ-ACK pattern:

HARQ-ACK cycle = [Inter TTI Distance \(Interval\)](#) \* "HARQ-ACK Repeat After"

Remote command:

`[ :SOURCE<hw> ] :BB:W3GPP:MSTation<st>:DPCCh:HS:HACK:REPEAT`  
on page 381

**HARQ-ACK From Interval/ HARQ-ACK To Interval ← HARQ-ACK**

Defines the beginning/end of the HARQ-ACK transmissions inside the HARQ-ACK cycle (specified by [HARQ-ACK Repeat After](#)). The range is specified in multiples of intervals, determined by [Inter TTI Distance \(Interval\)](#).

See also [Figure 3-21](#).

Remote command:

`[ :SOURCE<hw> ] :BB:W3GPP:MSTation<st>:DPCCh:HS:ROW<ch0>:HACK:FROM`  
on page 377

`[ :SOURCE<hw> ] :BB:W3GPP:MSTation<st>:DPCCh:HS:ROW<ch0>:HACK:TO`  
on page 377

**HS-DPCCH 1/2, HARQ-ACK 1/2/3/4 ← HARQ-ACK**

Per HS-DPCCHs, sets the information transmitted during the HARQ-ACK slots of the TTIs during the corresponding specified "HARQ-ACK From/To" range.

Two HS-DPCCHs are transmitted, if "Secondary Cell Enabled > 3".

The number of enabled HARQ-ACKs depends on the combination of enabled and active secondary cells. In this implementation, the activated cells are mapped from left to right.

The processing of HS-DPCCH is defined for four different main cases (see [Table 3-10](#)).

**Table 3-10: HS-DPCCH processing**

Mode	"MIMO Mode"	"Secondary Cell Enabled"	"Secondary Cell Active"	Comment
Normal operation	Off	0	0	-
MIMO only	On	0	0	see <a href="#">Chapter 2.3.14.5, "MIMO uplink control channel support"</a> , on page 33
DC-HSDPA only 4C/8C-HSDPA only	Off	1 2 to 7	0, 1 2 to 7	see <a href="#">Chapter 2.3.15.1, "DC-HSDPA data acknowledgement (non-MIMO mode)"</a> , on page 37  see <a href="#">Chapter 2.3.16, "HS-DPCCH extension for 4C-HSDPA and 8C-HSDPA"</a> , on page 40
DC-HSDPA +MIMO 4C/8C-HSDPA +MIMO	On	1 2 to 7	1 2 to 7	see <a href="#">Chapter 2.3.15.2, "DC-HSDPA + MIMO"</a> , on page 39  see <a href="#">Chapter 2.3.16, "HS-DPCCH extension for 4C-HSDPA and 8C-HSDPA"</a> , on page 40

Meaning of the used abbreviations:

- **A** indicates an ACK response; **N** - an NACK
- **D** means no transmission (DTX), i.e. no transport block was sent on the corresponding HS-DSCH downlink transmission.
- Single letter, e.g. an **A** indicates a response to a single scheduled transport block (TB)
- A letter's couple, e.g. an **AA** indicates two MIMO streams, i.e. the response on two TBs
- / is a separation mark between the response to the serving and secondary cells, where the feedback related to the serving HS-DSCH cell is the one before the divider sign.

#### Example: Understanding the syntax

For better representation of the principle, the sending of ACK only messages is assumed.

HARQ-ACK value	Description
A/A/A	"MIMO Mode = Off" (single letters only) Three active cells, one serving and two secondary serving cells; one single TB transmission per cell
AA/A	"MIMO Mode = On" Two active cells, one serving with two MIMO streams and one secondary serving cell with single TB transmission
AA/AA	"MIMO Mode = On" Two active cells, each transmitting two MIMO streams

HARQ-ACK value	Description
AA/AA, AA/D	"MIMO Mode = On" Three active cells, each transmitting two MIMO streams
AA/AA, AA/AA	"MIMO Mode = On" Four active cells, each transmitting two MIMO streams

- "DTX" No HARQ-ACK feedback information is sent.
- "A, N" Selects an ACK or NACK response to a single scheduled transport block.
- "AA, AN, NA, NN" ("MIMO Mode > On", "Secondary Cell Enabled/Active = 0")  
Selects the response to two scheduled transport blocks, i.e. feedback on the primary and secondary stream in a dual stream transmission.
- "A/D, N/A, ... (different combinations possible)" ("MIMO Mode > Off", "Secondary Cell Enabled < 2")  
Selects the response to a single scheduled transport block on each of the serving and secondary serving HS-DSCH cells.
- "A/D/D, N/D/D, ... (different combinations possible)" ("MIMO Mode > Off", "Secondary Cell Enabled = 2")  
Selects the response to a single scheduled transport block on each of the serving and the two secondary serving HS-DSCH cells.
- "AN/NN, D/AA, ... (different combinations possible)" ("MIMO Mode > On", "Secondary Cell Active = On")  
Selects the response to two scheduled transport blocks on each of the serving and secondary serving HS-DSCH cells.
- "PRE, POST" PRE or POST is sent in the HARQ-ACK slots of the corresponding TTI.

Remote command:

`[ :SOURCE<hw> ] :BB:W3GPP:MSTation<st>:DPCCh:HS:ROW<ch0>:HACK<di>`  
on page 377

#### Power Offset HARQ-ACK ← HARQ-ACK

Sets the power offset of an HARQ-ACK response relative to the "Power".

The power used during all HARQ-ACK slots during the corresponding specified "HARQ-ACK From/To" range is calculated as:

$$P_{\text{HARQ-ACK}} = \text{Power} + P_{\text{off\_HARQ-ACK}}$$

The value range is -10 dB to 10 dB.

The parameter is enabled for HARQ-ACK different than DTX.

While generating the HS-DPCCH signal in real time, the HARQ-ACK power offsets of all configured HARQ-ACK responses are set to the same value.

Remote command:

`[ :SOURCE<hw> ] :BB:W3GPP:MSTation<st>:DPCCh:HS:ROW<ch0>:POHACK`  
on page 379



**PCI / CQI**

Comprises the parameters provided for the independent configuration of the PCI/CQI reports scheduling.

**Number of Rows ← PCI / CQI**

This parameter determines the number of the rows in the PCI / CQI scheduling table.

Each row represents one TTI interval, as configured with the parameter [Inter TTI Distance \(Interval\)](#). The parameters set in the table are read out cyclically.

See also [Figure 3-21](#).

Remote command:

`[ :SOURCE<hw> ] :BB:W3GPP:MSTation<st>:DPCCh:HS:PCQI:ROWS` on page 377

**PCI/CQI Repeat After ← PCI / CQI**

Defines the cycle length after that the information in the HS-DPCCH scheduling table is read out again from the beginning.

The parameter together with the parameter [Inter TTI Distance \(Interval\)](#) defines the repetition cycle of the PCI/CQI pattern:

PCI/CQI cycle = [Inter TTI Distance \(Interval\)](#) \* "PCI/CQI Repeat After"

Remote command:

`[ :SOURCE<hw> ] :BB:W3GPP:MSTation<st>:DPCCh:HS:PCQI:REPEAT`  
on page 381

**PCI-CQI From Interval/ PCI-CQI To Interval ← PCI / CQI**

Defines the beginning/ end of the PCI/CQI transmissions inside the PCI/CQI cycle (specified by [PCI/CQI Repeat After](#)). The range is specified in multiples of intervals, defined by [Inter TTI Distance \(Interval\)](#).

See also [Figure 3-21](#).

Remote command:

`[ :SOURCE<hw> ] :BB:W3GPP:MSTation<st>:DPCCh:HS:ROW<ch0>:PCQI:FROM`  
on page 379  
`[ :SOURCE<hw> ] :BB:W3GPP:MSTation<st>:DPCCh:HS:ROW<ch0>:PCQI:TO`  
on page 379

**HS-DPCCH 1/2, PCI/CQI 1/2/3/4 Type ← PCI / CQI**

Per HS-DPCCH, selects the type of the PCI/CQI report (see [CQI reports: type a and type b](#) and [CQI reports: CQI1 and CQI2](#)).

Two HS-DPCCHs are required, if "Secondary Cell Enabled > 3".

The number of enabled PCI/CQIs depends on the number of required HS-DPCCHs and the "Slot Format". In this implementation, the activated cells are mapped from left to right.

The available values depend on the state of the parameters "MIMO Mode", "Secondary Cell Enabled" and "Secondary Cell Active".

"DTX"                    No PCI/CQI feedback information is sent.

"CQI"                    Selects CQI report for the normal operation.

**"Type A Single TB"**

(MIMO Mode On)

Selects CQI Type A report with information that one transport block is preferred.

**"Type A Double TB"**

(MIMO Mode On)

Selects CQI Type A report with information that two transport blocks are preferred.

**"Type B"**

(MIMO Mode On)

Selects CQI Type B report.

**"Composite CQI"**

(MIMO Mode Off, "Secondary Cell Enabled = Secondary Cell Active ≤ 2")

Selects a composite CQI, constructed from the two individual reports CQI1 and CQI2 of the serving and secondary serving HS-DSCH cell.

Remote command:

```
[ :SOURCE<hw> ] :BB:W3GPP:MSTation<st>:DPCCh:HS:ROW<ch0>:PCQI<di>:
TYPE on page 379
```

**Power Offset PCI/CQI ← PCI / CQI**Sets the power offset  $P_{\text{off\_PCI/CQI}}$  of all PCI/CQI slots during the corresponding specified PCI/CQI From/To range relative to the **Power**.The power  $P_{\text{PCI/CQI}}$  used during the PCI/CQI slots is calculated as:

$$P_{\text{PCI/CQI}} = \text{Power} + P_{\text{off\_PCI/CQI}}$$

The value range is -10 dB to 10 dB.

While generating the HS-DPCCH signal in real time, the PCI/CQI power offsets of all configured PCI/CQI slots are set to the same value.

Remote command:

```
[ :SOURCE<hw> ] :BB:W3GPP:MSTation<st>:DPCCh:HS:ROW<ch0>:POPCqi
on page 380
```

**PCI/CQI 1/2/3/4 Content ← PCI / CQI**

Accesses a dialog for configuring the PCI and CQI report. The provided settings depend on the selected "PCI/CQI Type".

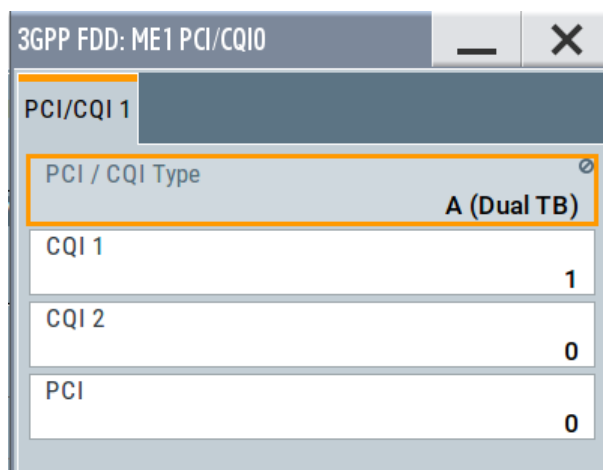

#### **CQI/CQI<sub>s</sub>/CQI<sub>1</sub>/CQI<sub>2</sub> ← PCI/CQI 1/2/3/4 Content ← PCI / CQI**

Sets the CQI report transmitted during the PCI/CQI slots of the TTIs during the corresponding specified PCI/CQI From/To range (see [Chapter 2.3.14.6, "CQI reports: type a and type b"](#), on page 35 and ["CQI reports: CQI1 and CQI2"](#) on page 39).

- "CQI" Sets the CQI value for CQI Type B report and the CQI in normal operation.
- "CQI<sub>s</sub>" Sets the CQI value in case a CQI Type A report when one transport block is preferred.
- "CQI<sub>1</sub>" Sets the CQI<sub>1</sub> value of CQI Type A report when two transport blocks are preferred or the CQI<sub>1</sub> value of a composite CQI report of a dual cell only operation.
- "CQI<sub>2</sub>" Sets the CQI<sub>2</sub> value of CQI Type A report when two transport blocks are preferred or the CQI<sub>2</sub> value of a composite CQI report of a dual cell only operation.

Remote command:

`[ :SOURCE<hw> ] :BB:W3GPP:MSTation<st>:DPCCh:HS:ROW<ch0>:PCQI<di>:CQI<us>` on page 380

#### **PCI ← PCI/CQI 1/2/3/4 Content ← PCI / CQI**

Selects the PCI value transmitted during the PCI/CQI slots of the TTIs during the corresponding specified PCI/CQI From/To range (see [PCI reports](#)).

Remote command:

`[ :SOURCE<hw> ] :BB:W3GPP:MSTation<st>:DPCCh:HS:ROW<ch0>:PCQI<di>:PCI` on page 380

#### **Suggested / Current ARB Seq. Length (HS-DPCCH)**

Displays the suggested and current ARB sequence length, in case the signal is not generated in real time.

The "Suggested ARB Sequence Length" is the calculated minimum length that depends on the [Inter TTI Distance \(Interval\)](#), the [Number of Rows/Number of Rows](#), the [HARQ-ACK Repeat After](#) and the [PCI/CQI Repeat After](#). The current ARB sequence length is adjusted by pressing the button "Adjust ARB Sequence Length".

**Example: Effect of the ARB sequence length**

- Preset the instruments and adjust the settings as described in [Example"HS-DPCCH scheduling"](#) on page 180. Use the [Scheduling list](#) to show the HS-DPCCH scheduling (see also [Figure 3-21](#)).
- Change the [Compatibility Mode \(HS-DPCCH\)](#) to "Release 8 and Later" and compare the displayed HS-DPCCH scheduling in the "Scheduling List".

**Real-time signal generation**

3GPP FDD: UE1/Scheduling List

Frame Start: 0, Number Of Frames: 10

]: The channel is inactive in the slot.  
X: The channel is active in the slot.  
-: The channel is inactive in the symbol.  
H: HARQ-ACK information is transmitted in the symbol.  
C: PCI/CQI information is transmitted in the symbol.

Frame Number:	Slot Number:	DPCCH Slots:	DPDCH Slots:	HS-DPCCH Symbols:
0	0	X	X	-----
	1	X	X	-----
	2	X	X	-----
	3	X	X	-----
	4	X	X	-----
	5	X	X	-----
	6	X	X	-----
	7	X	X	-----
	8	X	X	-----
	9	X	X	-----
	10	X	X	-----
	11	X	X	-----
	12	X	X	-----
	13	X	X	-----
	14	X	X	-----
1	0	X	X	-----
	1	X	X	-----
	2	X	X	-----
	3	X	X	-----
	4	X	X	-----
	5	X	X	-----
	6	X	X	-----
	7	X	X	-----
	8	X	X	-----
	9	X	X	-----
	10	X	X	-----
	11	X	X	-----
	12	X	X	-----

**ARB signal generation with "Current ARB Seq. Length" < "Suggested ARB Seq. Length"**

3GPP FDD: UE1/Scheduling List

Frame Start: 0, Number Of Frames: 10

]: The channel is inactive in the slot.  
X: The channel is active in the slot.  
-: The channel is inactive in the symbol.  
H: HARQ-ACK information is transmitted in the symbol.  
C: PCI/CQI information is transmitted in the symbol.  
-.: The channel restarts because of the ARB sequence length.

Frame Number:	Slot Number:	DPCCH Slots:	DPDCH Slots:	HS-DPCCH Symbols:
0	0	X	X	-----
	1	X	X	-----
	2	X	X	-----
	3	X	X	-----
	4	X	X	-----
	5	X	X	-----
	6	X	X	-----
	7	X	X	-----
	8	X	X	-----
	9	X	X	-----
	10	X	X	-----
	11	X	X	-----
	12	X	X	-----
	13	X	X	-----
	14	X	X	-----
1	0	X	X	-----
	1	X	X	-----
	2	X	X	-----
	3	X	X	-----
	4	X	X	-----
	5	X	X	-----
	6	X	X	-----
	7	X	X	-----
	8	X	X	-----
	9	X	X	-----
	10	X	X	-----

- The "Suggested / Current ARB Sequence Length" is 12 / 1. Press the [Adjust ARB Sequence Length \(HS-DPCCH\)](#). The "Current ARB Seq. Length" is adjusted, the channel restarts after 12 frames and the "Scheduling List" shows the HS-DPCCH scheduling in all frames as in the real-time mode.

**Tip:** To ensure a long enough ARB sequence, select "3GPP FDD > Filter/Clipping/ARB Settings" and adjust the [Sequence Length ARB](#) so that the ARB sequence length is multiple or equal the scheduling repetition.

Remote command:

[ :SOURCE<hw> ] :BB:W3GPP:MSTation<st>:DPCCh:HS:SLENgth? on page 381

**Adjust ARB Sequence Length (HS-DPCCH)**

Sets the current ARB sequence length to the suggested value (see also [Example"Effect of the ARB sequence length"](#) on page 188).

Remote command:

[ :SOURCE<hw> ] :BB:W3GPP:MSTation<st>:DPCCh:HS:SLENgth:ADJust on page 382

### 3.30.4 HS-DPCCH settings for normal operation (up to Release 7)

The R&S SMBV100B supports also the parameters for backward compatibility.

Access:

1. Select "3GPP FDD > Link Direction > Uplink / Reverse > User Equipments > UE"
2. Select "HS-DPCCH".
3. Select "Compatibility Mode > Up to Release 7".

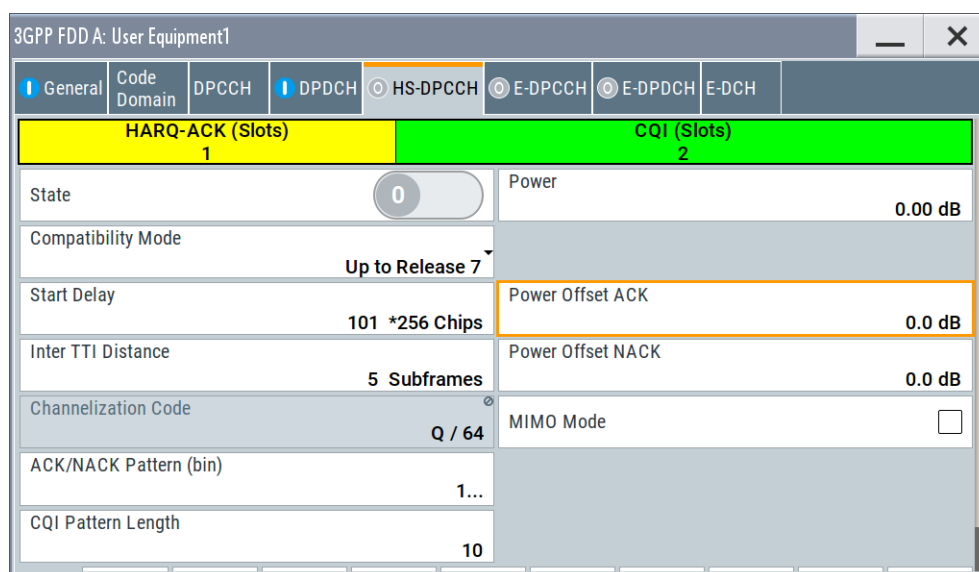

The dialog contains the parameters that were available up to the selected release.

#### Power Offset ACK

Sets the power offset  $P_{\text{off\_ACK}}$  of an ACK response to a single scheduled transport block relative to the CQI Power  $P_{\text{CQI}}$ .

The power  $P_{\text{ACK}}$  used during the HARQ-ACK slot is calculated as:

$$P_{\text{ACK}} = P_{\text{CQI}} + P_{\text{off\_ACK}}$$

The value range is -10 dB to 10 dB.

Remote command:

`[ :SOURCE<hw> ] :BB:W3GPP:MSTation<st>:DPCCh:HS:POACK` on page 367

#### Power Offset NACK

Sets the power offset  $P_{\text{off\_NACK}}$  of an NACK response to a single scheduled transport block relative to the CQI Power  $P_{\text{CQI}}$ .

The power  $P_{\text{NACK}}$  used during the HARQ-ACK slot is calculated as:

$$P_{\text{NACK}} = P_{\text{CQI}} + P_{\text{off\_NACK}}$$

The value range is -10 dB to 10 dB.

Remote command:

`[ :SOURCE<hw> ] :BB:W3GPP:MSTation<st>:DPCCh:HS:PONACK` on page 367

**ACK/NACK Pattern**

(for "MIMO Mode &gt; Off")

Enters the pattern for the HARQ-ACK field (Hybrid-ARQ Acknowledgment).

After receiving a transmission packet, the user equipment returns feedback information in the HARQ-ACK field that is related to the accuracy of downlink HS-DSCH transmission.

1 bit is used per HS-DPCCH packet. The maximum length of the pattern is 32 bits.

""1" = ACK"      The HARQ ACK is sent. Transmission was successful and correct.

""0" = NACK"      The NACK is sent. Transmission was not correct. With an NACK, the UE requests retransmission of the incorrect data.

""-" = DTX"      Nothing is sent. Transmission is interrupted (discontinuous transmission (DTX)).

Remote command:

[\[:SOURCE<hw>\]:BB:W3GPp:MSStation<st>:DPCCh:HS:HAPattern](#) on page 367

**CQI Pattern Length**

(for "MIMO Mode &gt; Off")

Sets the length of the CQI sequence. The values of the CQI sequence are entered in input fields "CQI Values". The pattern is generated cyclically.

With the CQI (channel quality indicator), the user equipment informs the base station about the receive quality of the downlink HS-PDSCH.

Thus, the base station can adapt the modulation and coding scheme to improve the signal quality. The instrument supports the control of the base station HS-PDSCH by CQI sequences with a length of 1 to 10 values.

Remote command:

[\[:SOURCE<hw>\]:BB:W3GPp:MSStation<st>:DPCCh:HS:CQI:PLENgtH](#) on page 368

**CQI Values**

(for "MIMO Mode &gt; Off")

Enters the values of the CQI sequence. Value -1 means that no CQI is sent (DTX).

The length of the CQI sequence is set at input field CQI Length. The pattern is generated cyclically.

With the CQI, the user equipment informs the base station about the receive quality of the downlink HS-PDSCH. Thus, the base station can adapt the modulation and coding scheme to improve the signal quality. The instrument supports the control of the base station HS-PDSCH by CQI sequences with a length of 1 to 10 values.

Remote command:

[\[:SOURCE<hw>\]:BB:W3GPp:MSStation<st>:DPCCh:HS:CQI<ch>\[:VALues\]](#) on page 368

**MIMO Mode (Up to Release 7)**

Option: R&S SMBVB-K83

Enables/disables working in MIMO mode for the selected UE.

When MIMO mode is enabled, the parameters ACK/NACK pattern, CQI pattern length and CQI values are not available. Several MIMO-specific parameters are enabled for configuration (see [Chapter 3.30.5, "MIMO settings HS-DPCCH \(up to Release 7\)"](#), on page 191s).

Remote command:

```
[ :SOURCE<hw> ] :BB:W3Gpp:MSTation<st>:DPCCh:HS:MIMO [ :MODE ]
```

on page 369

### 3.30.5 MIMO settings HS-DPCCH (up to Release 7)



Option: R&S SMBVB-K83 and "MIMO Mode > On" for MIMO settings.

Access:

1. Select "3GPP FDD > Link Direction > Uplink / Reverse > User Equipments > UE"
2. Select "HS-DPCCH".
3. Select "Compatibility Mode > Up to Release 7".
4. Select "MIMO Mode > On".

3GPP FDD A: User Equipment1	
General	Code Domain
DPCCH	DPDCH
HS-DPCCH	E-DPCCH
E-DPDCH	E-DCH
<b>HARQ-ACK (Slots) 1</b>	
<b>PCI / CQI (Slots) 2</b>	
State	0
Compatibility Mode	Up to Release 7
Start Delay	101 *256 Chips
Inter TTI Distance	5 Subframes
Channelization Code	Q / 64
MIMO Settings	
Power Offset ACK/ACK	0.0 dB
Power Offset NACK/ACK	0.0 dB
Power	0.00 dB
Power Offset ACK	0.0 dB
Power Offset NACK	0.0 dB
MIMO Mode	<input checked="" type="checkbox"/>
Power Offset ACK/NACK	0.0 dB
Power Offset NACK/NACK	0.0 dB

The available settings allow you to adjust the HS-DPCCH configuration for UE configured in MIMO mode.

The HS-DPCCH structure can be configured with the parameters [Inter TTI Distance](#) and [Number of TTIs](#). The HS-DPCCH structure can also be configured by changing the HARQ-ACK and CQI/PCI information per TTI by means of the parameters of the HS-DPCCH scheduling table. Any combination of single or dual transport block [HARQ-](#)

ACK, PCI value, CQI Type and corresponding CQI value(s), as well as channel power can be configured.

#### Power Offset ACK/ACK

Sets the power offset  $P_{\text{off\_ACK/ACK}}$  of an ACK/ACK response to two scheduled transport blocks relative to the CQI Power  $P_{\text{CQI}}$ .

The power  $P_{\text{ACK/ACK}}$  used during the HARQ-ACK slots is calculated as:

$$P_{\text{ACK/ACK}} = P_{\text{CQI}} + P_{\text{off\_ACK/ACK}}$$

The value range is -10 dB to 10 dB.

Remote command:

`[ :SOURCE<hw> ] :BB:W3GPP:MSTation<st>:DPCCh:HS:MIMO:POAAck`  
on page 369

#### Power Offset ACK/NACK

Sets the power offset  $P_{\text{off\_ACK/NACK}}$  of an ACK/NACK response to two scheduled transport blocks relative to the CQI Power  $P_{\text{CQI}}$ .

The power  $P_{\text{ACK/NACK}}$  used during the HARQ-ACK slots is calculated as:

$$P_{\text{ACK/NACK}} = P_{\text{CQI}} + P_{\text{off\_ACK/NACK}}$$

The value range is -10 dB to 10 dB.

Remote command:

`[ :SOURCE<hw> ] :BB:W3GPP:MSTation<st>:DPCCh:HS:MIMO:POANack`  
on page 370

#### Power Offset NACK/ACK

Sets the power offset  $P_{\text{off\_NACK/ACK}}$  of an NACK/ACK response to two scheduled transport blocks relative to the CQI Power  $P_{\text{CQI}}$ .

The power  $P_{\text{NACK/ACK}}$  used during the HARQ-ACK slots is calculated as:

$$P_{\text{NACK/ACK}} = P_{\text{CQI}} + P_{\text{off\_NACK/ACK}}$$

The value range is -10 dB to 10 dB.

Remote command:

`[ :SOURCE<hw> ] :BB:W3GPP:MSTation<st>:DPCCh:HS:MIMO:PONack`  
on page 370

#### Power Offset NACK/NACK

Sets the power offset  $P_{\text{off\_NACK/NACK}}$  of an NACK/NACK response to two scheduled transport blocks relative to the CQI Power  $P_{\text{CQI}}$ .

The power  $P_{\text{NACK/NACK}}$  used during the HARQ-ACK slots is calculated as:

$$P_{\text{NACK/NACK}} = P_{\text{CQI}} + P_{\text{off\_NACK/NACK}}$$

The value range is -10 dB to 10 dB.

Remote command:

`[ :SOURCE<hw> ] :BB:W3GPP:MSTation<st>:DPCCh:HS:MIMO:PONNack`  
on page 371



**Power Offset CQI Type A**

Sets the power offset  $P_{\text{off\_CQI Type A}}$  of the PCI/CQI slots in case a CQI Type A report is sent relative to the CQI Power  $P_{\text{CQI}}$ .

The power  $P_{\text{CQI Type A}}$  used during the PCI/CQI slots is calculated as:

$$P_{\text{CQI Type A}} = P_{\text{CQI}} + P_{\text{off\_CQI Type A}}$$

Since the CQI Type B reports are used in a single stream transmission (see [Chapter 2.3.14.6, "CQI reports: type a and type b"](#), on page 35), the power  $P_{\text{CQI Type B}} = P_{\text{CQI}}$ .

The value range is -10 dB to 10 dB.

Remote command:

`[ :SOURCE<hw> ] :BB:W3GPP:MSTation<st>:DPCCh:HS:MIMO:POCA` on page 371

**Number of TTIs (Up to Release 7)**

Selects the number of configurable TTIs.

This parameter determines the number of the rows in the HS-DPCCH scheduling table. Each row represents one TTI. The parameters set in the table are read out cyclically.

Remote command:

`[ :SOURCE<hw> ] :BB:W3GPP:MSTation<st>:DPCCh:HS:MIMO:TTICount`  
on page 372

**MIMO Settings Table**

Comprises the parameters provided for active MIMO Mode.

**HARQ-ACK (Up to Release 7) ← MIMO Settings Table**

Selects the information transmitted during the HARQ-ACK slot of the corresponding TTI (see [Chapter 2.3.14.5, "MIMO uplink control channel support"](#), on page 33).

"DTX" Selects discontinuous transmission (DTX) for the corresponding TTI. During that TTI, no feedback information is sent, i.e. all other parameters in the feedback signaling table are disabled.

"Single TB: ACK/Single TB: NACK" Selects an ACK or NACK response to a single scheduled transport block.

"TB1:ACK,TB2:ACK / TB1:ACK,TB2:NACK / TB1:NACK,TB2:ACK / TB1:NACK,TB2:NACK" Selects the response to two scheduled transport blocks.

Remote command:

`[ :SOURCE<hw> ] :BB:W3GPP:MSTation<st>:DPCCh:HS:MIMO:TTI<ch0>:HACK`  
on page 372

**PCI (Up to Release 7) ← MIMO Settings Table**

Selects the PCI value transmitted during the PCI/CQI slots of the corresponding TTI (see [Chapter 2.3.14.7, "PCI reports"](#), on page 35).

Remote command:

`[ :SOURCE<hw> ] :BB:W3GPP:MSTation<st>:DPCCh:HS:MIMO:TTI<ch0>:PCI`  
on page 373

**CQI Type (Up to Release 7) ← MIMO Settings Table**

Selects the type of the CQI report (see [Chapter 2.3.14.6, "CQI reports: type a and type b"](#), on page 35).

"Type A Single TB"

Selects CQI Type A report with information that one transport block is preferred.

"Type A Double TB"

Selects CQI Type A report with information that two transport blocks are preferred.

"Type B"

Selects CQI Type B report.

Remote command:

`[ :SOURCE<hw> ] :BB:W3GPP:MSTation<st>:DPCCh:HS:MIMO:TTI<ch0>:CQIType` on page 373

**CQI/CQI<sub>s</sub>/CQI<sub>1</sub>/CQI<sub>2</sub> (Up to Release 7) ← MIMO Settings Table**

Selects the CQI report transmitted during the PCI/CQI slots of the corresponding TTI (see [Chapter 2.3.14.6, "CQI reports: type a and type b"](#), on page 35).

"CQI"

Sets the CQI value for CQI Type B report.

"CQI<sub>s</sub>"

Sets the CQI value in case a CQI Type A report when one transport block is preferred.

"CQI<sub>1</sub>"

Sets the CQI<sub>1</sub> value of CQI Type A report when two transport blocks are preferred.

"CQI<sub>2</sub>"

Sets the CQI<sub>2</sub> value of CQI Type A report when two transport blocks are preferred.

Remote command:

`[ :SOURCE<hw> ] :BB:W3GPP:MSTation<st>:DPCCh:HS:MIMO:TTI<ch0>:CQI<di>` on page 373

### 3.31 E-DPCCH settings - UE

Access:

1. Select "3GPP FDD > Link Direction > Uplink / Reverse > User Equipments > UE".
2. Select "Mode > DPCCH + DPDCH".

## 3. Select "E-DPCCH".

Happy Bit	Retrans Sequence Number	E-TFCI Information
1	2	7
State	0	Power
Retransmission Sequence Number	0	Channelization Code
E-TFCI Information	0	Happy Bit
HSUPA FRC ...		

The dialog displays the channel structure and the available parameters.

**State (E-DPCCH)**

Activates or deactivates the E-DPCCH channel.

If an FRC is set for the channel, this field is activated automatically.

Remote command:

`[ :SOURCE<hw> ] :BB:W3GPP:MSTation<st> [ :HSUPa ] :DPCCh:E:STATE`  
on page 420

**Power**

Sets the power of the E-DPCCH channel.

The value range is -80 dB to 0 dB.

Remote command:

`[ :SOURCE<hw> ] :BB:W3GPP:MSTation<st> [ :HSUPa ] :DPCCh:E:POWER`  
on page 419

**Retransmission Sequence Number**

Sets the retransmission sequence number.

The value range is 0 to 3.

Remote command:

`[ :SOURCE<hw> ] :BB:W3GPP:MSTation<st> [ :HSUPa ] :DPCCh:E:RSNumber`  
on page 420

**Channelization Code**

Displays the channelization code and the modulation branch (always I) of the E-DPCCH. The code channel is spread with the set channelization code (spreading code). The standard assigns a fixed channelization code to the E-DPCCH.

Remote command:

`[ :SOURCE<hw> ] :BB:W3GPP:MSTation<st> [ :HSUPa ] :DPCCh:E:CCODE?`  
on page 419

#### **E-TFCI Information**

Sets the value for the TFCI (Transport Format Combination Indicator) field.

The value range is 0 to 127.

Remote command:

`[ :SOURCE<hw> ] :BB:W3GPP:MSTation<st> [ :HSUPa ] :DPCCh:E:TFCI`  
on page 420

#### **Happy Bit**

Activating the happy bit. This bit is indicating whether the UE could use more resources (Not Happy/deactivated) or not (Happy/activated).

Remote command:

`[ :SOURCE<hw> ] :BB:W3GPP:MSTation<st> [ :HSUPa ] :DPCCh:E:HBIT`  
on page 419

#### **HSUPA FRC...**

For UE1, accesses the dialog for configuring the FRC (Fixed Reference Channel), see [Chapter 3.32, "HSUPA FRC settings - UE"](#), on page 196.

Remote command:

n.a.

## **3.32 HSUPA FRC settings - UE**

The "UE HSUPA FRC" dialog provides the parameters for configuring the fixed reference channel (FRC) and the settings for the HARQ simulation.

For more information, see also [Chapter 2.3.13.4, "16QAM fixed reference channel: FRC 8"](#), on page 30.

### **3.32.1 FRC general settings**

Access:

1. Select "3GPP FDD > Link Direction > Uplink / Reverse > User Equipments > UE"

## 2. Select "E-DPCCH &gt; HSUPA FRC..."

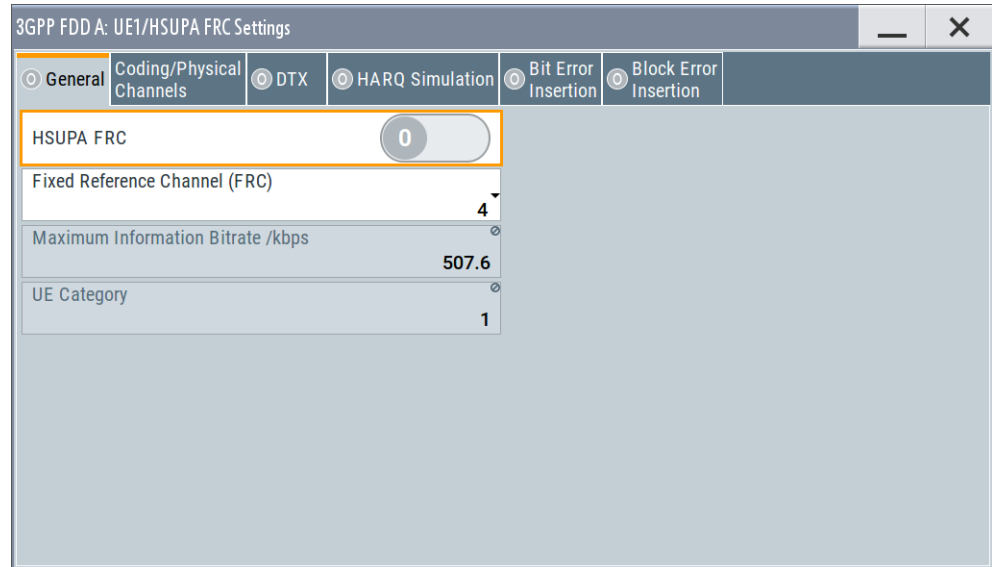

The dialog comprises the common settings for the fixed reference channel (FRC).

**State (HSUPA FRC)**

Activates or deactivates the FRC state for the E-DCH channels.

If FRC is activated, the channels E-DPCCH and E-DPDCH are automatically activated.

The following parameters of these channels are set automatically, depending on the configured FRC:

- For E-DPCCH:
  - "Retransmission Sequence Number" is set to 0  
"E-TFCI"
- For E-DPDCH:
  - **Overall Symbol Rate** is set according to the correspondent parameter of FRC. The "Modulation" is set according to the "Modulation" used for the selected FRC. The **E-DPDCH Data Source** is set according to the **Data Source (E-DCH)** used for the selected FRC.
- For E-DCH scheduling:
  - **E-DCH TTI** is set according to the **E-DCH TTI** of the selected FRC  
If the "HARQ Simulation" is disabled and the state in the DTX mode section is activated, the "E-DCH Scheduling Table" is configured according to the "**DTX Pattern**" specified.  
By enabled "HARQ Simulation", the settings in the "E-DCH Scheduling Table" are configured to ensure a continuous E-DCH transmission.

**Note:** HSUPA FRCs are disabled, if **UL-DTX... / User Scheduling State** or **Dynamic Power Control State** are activated.

Remote command:

```
[ :SOURce<hw> ] :BB:W3Gpp:MSTation<st> [ :HSUPa ] :DPCCh:E:FRC:STATe
```

on page 417

**Fixed Reference Channel (FRC)**

Selects the FRC according to TS 25.141, annex A.10.

Additionally, user defined FRC can be configured.

Option: R&S SMBVB-K83 for RFC8

Remote command:

`[ :SOURce<hw> ] :BB:W3GPP:MSTation<st> [ :HSUPa ] :DPCCh:E:FRC:CHANnel`  
on page 410

**Maximum Information Bitrate/kbps**

Displays the maximum information bit rate.

Remote command:

`[ :SOURce<hw> ] :BB:W3GPP:MSTation<st> [ :HSUPa ] :DPCCh:E:FRC:MIBRate?`  
on page 415

**UE Category**

Displays the UE category that is minimum required for the selected FRC (see also [Chapter 2.3.18.2, "UL 16QAM UE capabilities"](#), on page 41).

Remote command:

`[ :SOURce<hw> ] :BB:W3GPP:MSTation<st> [ :HSUPa ] :DPCCh:E:FRC:UECategory?`  
on page 419

**3.32.2 Coding and physical channels settings**

Access:

1. Select "3GPP FDD > Link Direction > Uplink / Reverse > User Equipments > UE"
2. Select "E-DPCCH > HSUPA FRC...> Coding/Physical Channels"

Parameter	Value
Data Source (E-DCH) Pattern	0...
Overall Symbol Rate	960 kbps
E-DCH TTI	10 ms
Number Of HARQ Processes	4
Binary Channel Bits / TTI (Nbin)	9 600
Transport Block Size Table	Table 1 (10ms)
Transport Block Size Index (E-TFCI)	41
Information Bit Payload (Ninf)	5 076
Coding Rate (Ninf/Nbin)	0.529

This dialog comprises the parameters required for configuring the physical channel settings and coding.

### Data Source (E-DCH)

Selects the data source for the E-DCH channels, i.e. this parameter affects the corresponding parameter of the E-DPDCH.

The following standard data sources are available:

- "All 0, All 1"  
An internally generated sequence containing 0 data or 1 data.
- "PNxx"  
An internally generated pseudo-random noise sequence.
- "Pattern"  
An internally generated sequence according to a bit pattern.  
Use the "Pattern" box to define the bit pattern.
- "Data List/Select DList"  
A binary data from a data list, internally or externally generated.  
Select "Select DList" to access the standard "Select List" dialog.
  - Select the "Select Data List > navigate to the list file \*.dm\_iqd > Select" to select an existing data list.
  - Use the "New" and "Edit" functions to create internally new data list or to edit an existing one.
  - Use the standard "File Manager" function to transfer external data lists to the instrument.

See also:

- Section "Modulation Data" in the R&S SMBV100B user manual.
- Section "File and Data Management" in the R&S SMBV100B user manual.
- Section "Data List Editor" in the R&S SMBV100B user manual

Remote command:

`[ :SOURCE<hw> ] :BB:W3GPp:MSTation<st> [ :HSUPa ] :DPCCh:E:FRC:DATA`  
on page 410

`[ :SOURCE<hw> ] :BB:W3GPp:MSTation<st> [ :HSUPa ] :DPCCh:E:FRC:DATA:`  
`PATtern` on page 411

`[ :SOURCE<hw> ] :BB:W3GPp:MSTation<st> [ :HSUPa ] :DPCCh:E:FRC:DATA:`  
`DSElect` on page 411

### Overall Symbol Rate

Sets the overall symbol rate for the E-DCH channels, i.e. this parameter affects the corresponding parameter of the E-DPDCH.

Remote command:

`[ :SOURCE<hw> ] :BB:W3GPp:MSTation<st> [ :HSUPa ] :DPCCh:E:FRC:ORATE`  
on page 416

### Modulation

Sets the modulation of the FRC, i.e. this parameter affects the corresponding parameter of the E-DPDCH.

There are two possible modulation schemes specified, BPSK and 4PAM (4 Pulse Amplitude Modulation). The latter one is available only for the following [Overall Symbol Rates](#):

- 2x960 ksps
- 2x1920 ksps
- 2x960 + 2x1920 ksps.

**Note:** Option: R&S SMBVB-K83 for 4PAM

Remote command:

```
[ :SOURce<hw> ] :BB:W3GPp:MSTation<st> [ :HSUPa ] :DPCCh:E:FRC:
MODulation on page 416
```

### E-DCH TTI

Sets the size of the TTI (Transmission Time Interval) for the E-DCH channels, i.e. this parameter affects the corresponding parameter of the E-DCH scheduling configuration.

Remote command:

```
[ :SOURce<hw> ] :BB:W3GPp:MSTation<st> [ :HSUPa ] :DPCCh:E:FRC:TTIEdch
on page 418
```

### Number Of HARQ Processes

Displays the number of HARQ (Hybrid-ARQ acknowledgement) processes. This value determines the distribution of the payload in the subframes.

Remote command:

```
[ :SOURce<hw> ] :BB:W3GPp:MSTation<st> [ :HSUPa ] :DPCCh:E:FRC:
HPRocesses? on page 415
```

### Binary Channel Bits / TTI (Nbin)

Displays the number of binary bits per TTI.

### Transport Block Size Table

Selects the transport block size table from 3GPP TS 25.321, annex B according to that the transport block size is configured.

The transport block size is determined also by the parameter "Transport Block Size Index".

The allowed values of this parameter depend on the selected "E-DCH TTI" and "Modulation" scheme.

E-DCH TTI	Modulation	Transport block size table	Transport block size index (E-TFCI)
2 ms	BPSK	Table 0	0 .. 127
		Table 1	0 .. 125
	4PAM	Table 2	0 .. 127
		Table 3	0 .. 124
10 ms	-	Table 0	0 .. 127
		Table 1	0 .. 120



Remote command:

```
[ :SOURCE<hw> ] :BB:W3GPP:MSTation<st> [ :HSUPa ] :DPCCh:E:FRC:TBS:TABLE on page 417
```

#### Transport Block Size Index (E-TFCI)

Selects the transport block size index (E-TFCI) for the corresponding table, as described in 3GPP TS 25.321, annex B.

The value range of this parameter depends on the selected "Transport Block Size Table".

Remote command:

```
[ :SOURCE<hw> ] :BB:W3GPP:MSTation<st> [ :HSUPa ] :DPCCh:E:FRC:TBS:INDEX on page 417
```

#### Information Bit Payload (Ninf)

Displays the payload of the information bit. This value determines the number of transport layer bits sent in each HARQ process.

Remote command:

```
[ :SOURCE<hw> ] :BB:W3GPP:MSTation<st> [ :HSUPa ] :DPCCh:E:FRC:PAYBits? on page 416
```

#### Coding Rate (Ninf/Nbin)

Displays the relation between the information bits to binary channel bits.

Remote command:

```
[ :SOURCE<hw> ] :BB:W3GPP:MSTation<st> [ :HSUPa ] :DPCCh:E:FRC:CRATE? on page 410
```

### 3.32.3 DTX mode settings

Access:

1. Select "3GPP FDD > Link Direction > Uplink / Reverse > User Equipments > UE"

## 2. Select "E-DPCCH &gt; HSUPA FRC... &gt; DTX"

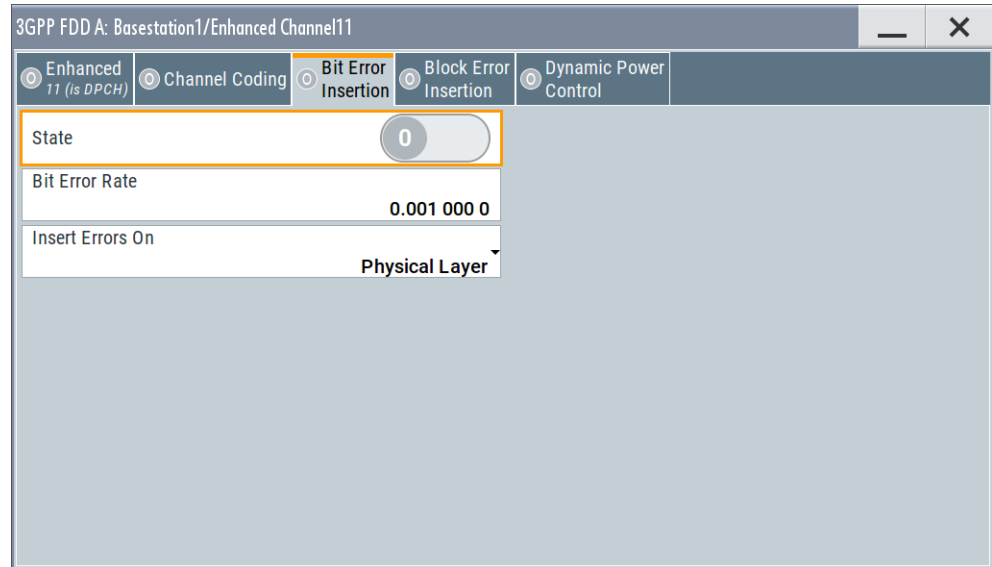

This dialog comprises the parameters required for enabling and defining user data.

**State (DTX)**

Activates or deactivates the DTX (discontinuous transmission) mode.

**Note:** If activated, the "E-DCH Scheduling Table" in the "E-DPCCH Settings" dialog is configured according to the "DTX Pattern" specified.

Remote command:

```
[ :SOURCE<hw> ] :BB:W3GPP:MSTation<st> [ :HSUPa ] :DPCCh:E:FRC:DTX:
STATE on page 413
```

**User Data (DTX Pattern)**

Sets the user-definable the bit pattern for the DTX. The maximum length is 64 bits.

The following values are allowed:

- 1: Data transmission
- -: DTX

**Note:** If activated, this setting overwrites the "E-DCH Scheduling Table" in the "E-DPCCH Settings" dialog.

**Example:**

"User Data (DTX Pattern) = 1-11-" sets the "E-DCH Scheduling" settings as follow:

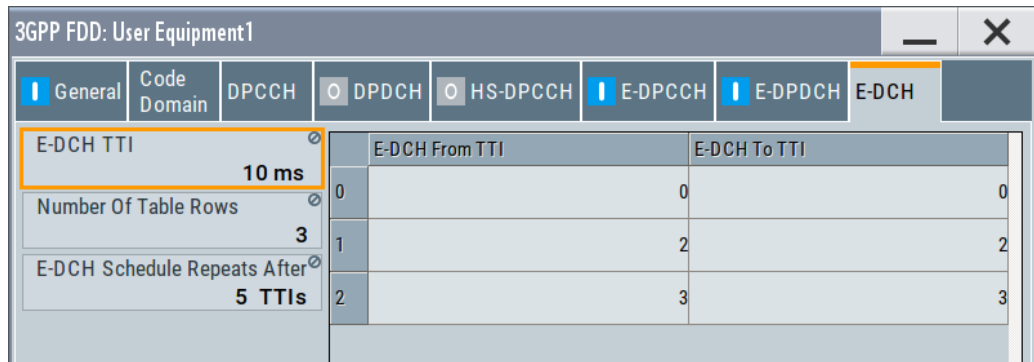

Remote command:

`[ :SOURCE<hw> ] :BB:W3GPP:MSTation<st> [ :HSUPA ] :DPCCh:E:FRC:DTX: PATTERN` on page 413

### 3.32.4 HARQ simulation settings

This section describes the HARQ settings. The provided settings depend on the selected "HARQ Simulation > Mode".

Access:

1. Select "3GPP FDD > Link Direction > Uplink / Reverse > User Equipments > UE".
2. Select "E-DPCCH > HSUPA FRC... > HARQ Simulation".
3. Select "Mode > Virtual HARQ".  
Select "HARQ Simulation > Virtual HARQ".

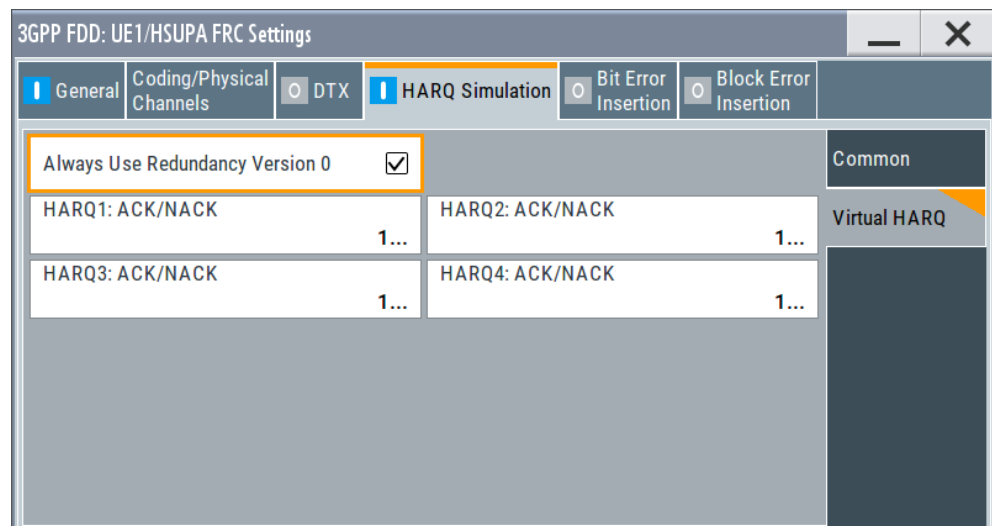

**State (HARQ)**

Activates or deactivates the HARQ simulation mode.

Remote command:

```
[ :SOURCE<hw> ] :BB:W3GPP:MSTation<st> [ :HSUPa ] :DPCCh:E:FRC:HARQ:
SIMulation[:STATe] on page 414
```

**Mode (HARQ)**

Selects the HARQ simulation mode.

"Virtual HARQ" This mode simulates base station feedback. For every HARQ process (either 4 or 8), a bit pattern can be defined to simulate ACKs and NACKs.

Remote command:

```
[ :SOURCE<hw> ] :BB:W3GPP:MSTation<st> [ :HSUPa ] :DPCCh:E:FRC:HARQ:
SIMulation:MODE on page 414
```

**Virtual HARQ Mode**

Simulates a base station feedback with the following settings:

**Always Use Redundancy Version 0 (HARQ) ← Virtual HARQ Mode**

If activated, the same redundancy version is sent, that is, the redundancy version is not adjusted for the next retransmission in case of a received NACK.

Remote command:

```
[ :SOURCE<hw> ] :BB:W3GPP:MSTation<st> [ :HSUPa ] :DPCCh:E:FRC:HARQ:
SIMulation:RVZero on page 414
```

**HARQ1..8: ACK/NACK ← Virtual HARQ Mode**

("HARQ Mode > Virtual HARQ")

Enters the pattern for the HARQ (Hybrid-ARQ acknowledgement).

The maximum length of the pattern is 32 bits.

""1" = ACK" New data is transmitted and the RSN (retransmission sequences number) is set to 0.

""0" = NACK" The data is retransmitted and the RSN is increased with 1. The maximum value of RSN is 3, i.e. even if more than three retransmissions are configured, the RSN remains 3.

Remote command:

```
[ :SOURCE<hw> ] :BB:W3GPP:MSTation<st> [ :HSUPa ] :DPCCh:E:FRC:HARQ [ :
SIMulation ] :PATtern<ch> on page 415
```

**3.32.5 Bit and block error insertion settings**

Access:

1. Select "3GPP FDD > Link Direction > Uplink / Reverse > User Equipments > UE"

2. Select "E-DPCCH > HSUPA FRC... > Bit/Block Error Insertion".

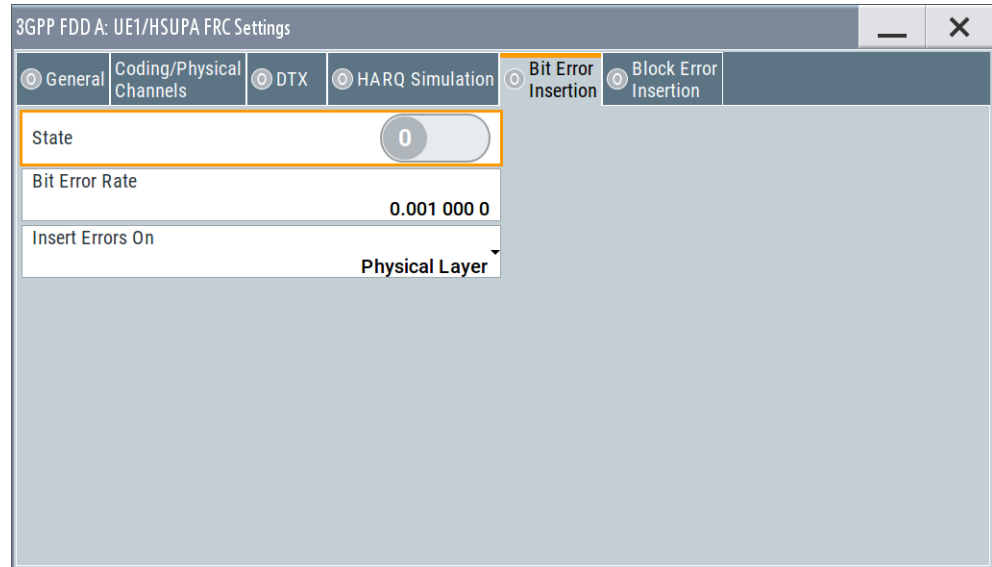

The dialogs provide the parameters for inserting errors into the data source and into the CRC checksum.

#### Bit Error State

Activates or deactivates bit error generation.

Bit errors are inserted into the data fields of the enhanced channels. It is possible to select the layer in which the errors are inserted (physical or transport layer).

When the data source is read out, bits are deliberately inverted at random points in the data bitstream at the specified error rate so that an invalid signal is simulated.

Remote command:

```
[ :SOURce<hw> ] :BB:W3GPp:MSTation<st> [ :HSUPa ] :DPCCh:E:FRC:DERRor:
BIT:STATE on page 412
```

#### Bit Error Rate

Sets the bit error rate. The value range is 10E-1 to 10E-7.

Remote command:

```
[ :SOURce<hw> ] :BB:W3GPp:MSTation<st> [ :HSUPa ] :DPCCh:E:FRC:DERRor:
BIT:RATE on page 412
```

#### Insert Errors On

Selects the layer in the coding process at which bit errors are inserted.

"Transport layer"

Bit errors are inserted in the transport layer.

"Physical layer"

Bit errors are inserted in the physical layer.

Remote command:

```
[ :SOURce<hw> ] :BB:W3GPp:MSTation<st> [ :HSUPa ] :DPCCh:E:FRC:DERRor:
BIT:LAYer on page 412
```

**Block Error State**

Activates or deactivates block error generation.

The CRC checksum is determined and then the last bit is inverted at the specified error probability in order to simulate an invalid signal.

Remote command:

`[ :SOURCE<hw> ] :BB:W3GPP:MSTation<st> [ :HSUPa ] :DPCCh:E:FRC:DERRor: BLOCk:STATE` on page 413

**Block Error Rate**

Sets block error rate.

Remote command:

`[ :SOURCE<hw> ] :BB:W3GPP:MSTation<st> [ :HSUPa ] :DPCCh:E:FRC:DERRor: BLOCk:RATE` on page 413

### 3.33 E-DPDCH settings - UE

Access:

1. Select "3GPP FDD > Link Direction > Uplink / Reverse > User Equipments > UE".
2. Select "Mode > DPCCH + DPDCH".
3. Select "E-DPDCH".

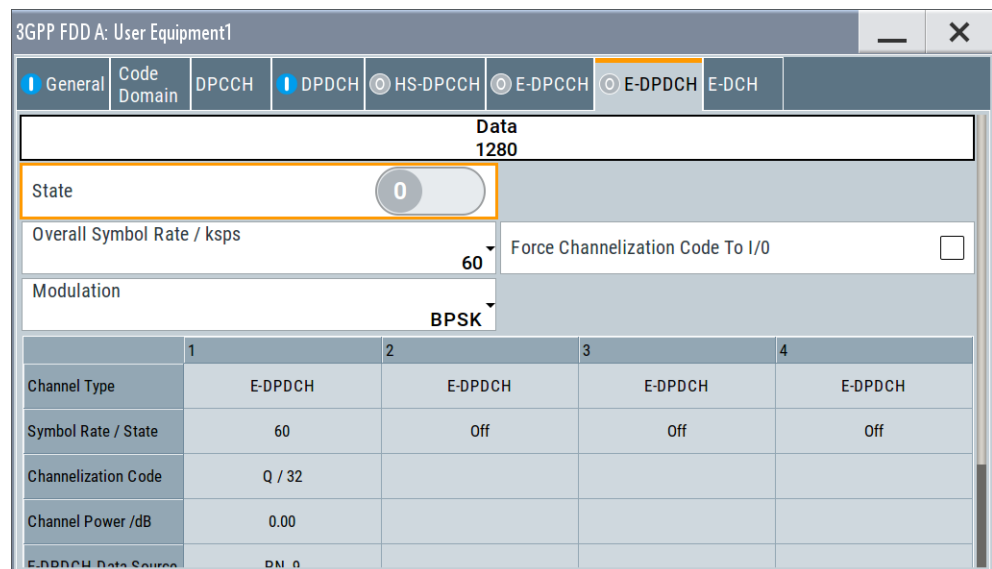

The dialog displays the channel structure and the available parameters.

### 3.33.1 E-DPDCH common settings

#### State (E-DPDCH)

Activates or deactivates all the E-DPDCH channels.

If an FRC is set for the channel, this field is activated automatically.

Remote command:

```
[ :SOURCE<hw> ] :BB:W3GPp:MSTation<st> [ :HSUPa ] :DPDCh:E:STATE
```

on page 422

#### Force Channelization Code To I/Q

Sets the channelization code to I/Q.

This mode can only be activated if the overall symbol rate is less than 2 x 960 kbps.

It is provided for test purposes. Using an oscilloscope, the data bits of the E-DPDCH are visible on the I/Q signal if:

- "Force Channelization Code to I/Q > On"
- "Scrambling Code Mode > Off"
- "DPDCH Power = - 80 dB"

Remote command:

```
[ :SOURCE<hw> ] :BB:W3GPp:MSTation<st> [ :HSUPa ] :DPDCh:E:FCIO
```

on page 421

#### Overall Symbol Rate

Sets the overall symbol rate of all the E-DPDCH channels.

The structure of the E-DPDCH channel table depends on this parameter. The overall symbol rate determines which E-DPDCHs are active, which symbol rate they have and which channelization codes they use.

E-DPDCHs that are not active by virtue of the overall rate are also disabled for operation.

If an FRC is set for the channel, this field is read-only.

**Note:** If the [Dynamic Power Control State](#) and/or the [UL-DTX... / User Scheduling State](#) is enabled, the E-DPDCH is generated in real time. Then only the overall symbol rates with one E-DPDCH channel or those that restrict the E-DPDCHs to the I or Q branch are enabled for configuration.

To send simultaneously multiple physical E-DPDCH, set the Overall Rate to one of the predefined two-channel configurations. For some special applications, it is necessary to split up the generation of these channels to two baseband blocks. The instrument provides also special non-standard overall symbol rates, that enable the instrument to generate only the E-DPDCH channels of the I branch or of the Q branch per baseband block.

Remote command:

```
[ :SOURCE<hw> ] :BB:W3GPp:MSTation<st> [ :HSUPa ] :DPDCh:E:ORATE
```

on page 421

#### Modulation

Sets the modulation of the E-DPDCH.

There are two possible modulation schemes specified for this channel, BPSK and 4PAM (4 Pulse-Amplitude Modulation). The latter one is available only for [Overall Symbol Rates](#) using two channels, e.g 2x960 ksps and/or 2x1920 ksps.

**Note:** Option: R&S SMBVB-K83 for 4PAM

Remote command:

`[ :SOURCE<hw> ] :BB:W3GPp:MSTation<st> [ :HSUPa ] :DPDCh:E:MODulation`  
on page 421

### 3.33.2 Channel table

The channel table allows you to configure the individual parameters for the E-DPDCH channels. The structure of the currently selected channel is displayed graphically in the table header.

The number of active channels depends on the selected overall symbol rate. You can select the data sources for the individual channels. The remaining parameters are only displayed and their values depend also on the overall symbol rate. See also [Table A-3](#) and [Table A-4](#).

#### Channel Number

Displays the channel number.

Remote command:

n.a.

(the channel is selected by the suffix at keyword `CHANnel<n>`)

#### Channel Type

Displays the channel type.

Remote command:

n.a.

#### Symbol Rate / State

Displays the symbol rate and the state of the E-DPDCH channel.

The symbol rate and the state of the channels depend on the overall symbol rate and cannot be modified.

Remote command:

`[ :SOURCE<hw> ] :BB:W3GPp:MSTation<st> [ :HSUPa ] :CHANnel<ch>:DPDCh:E:SRATE?` on page 409

#### Channelization Code

Displays the channelization code and the modulation branch (I or Q) of the DPDCH channel.

The channelization code depends on the overall symbol rate and cannot be modified.

Remote command:

`[ :SOURCE<hw> ] :BB:W3GPp:MSTation<st> [ :HSUPa ] :CHANnel<ch>:DPDCh:E:CCODE?` on page 407



**Channel Power / dB**

Sets the power of the selected E-DPDCH channel.

The power entered is relative to the powers of the other channels and does not initially relate to the "Level" power display. If [Adjust Total Power To 0 dB](#) is executed, all the power data is relative to "Level"

Remote command:

```
[ :SOURce<hw> ] :BB:W3GPP:MSTation<st> [ :HSUPa ] :CHANnel<ch> :DPDCh:E:
POWer on page 409
```

**E-DPDCH Data Source**

Selects the data source for the E-DPDCH channel.

The data source for the DPDCH is also entered here for the enhanced channels of UE1 without channel coding.

The following standard data sources are available:

- "All 0, All 1"  
An internally generated sequence containing 0 data or 1 data.
- "PNxx"  
An internally generated pseudo-random noise sequence.
- "Pattern"  
An internally generated sequence according to a bit pattern.  
Use the "Pattern" box to define the bit pattern.
- "Data List/Select DList"  
A binary data from a data list, internally or externally generated.  
Select "Select DList" to access the standard "Select List" dialog.
  - Select the "Select Data List > navigate to the list file \*.dm\_iqd > Select" to select an existing data list.
  - Use the "New" and "Edit" functions to create internally new data list or to edit an existing one.
  - Use the standard "File Manager" function to transfer external data lists to the instrument.

See also:

- Section "Modulation Data" in the R&S SMBV100B user manual.
- Section "File and Data Management" in the R&S SMBV100B user manual.
- Section "Data List Editor" in the R&S SMBV100B user manual

Remote command:

```
[ :SOURce<hw> ] :BB:W3GPP:MSTation<st> [ :HSUPa ] :CHANnel<ch> :DPDCh:E:
DATA on page 408
```

```
[ :SOURce<hw> ] :BB:W3GPP:MSTation<st> [ :HSUPa ] :CHANnel<ch> :DPDCh:E:
DATA: PATTern on page 409
```

```
[ :SOURce<hw> ] :BB:W3GPP:MSTation<st> [ :HSUPa ] :CHANnel<ch> :DPDCh:E:
DATA: DSElect on page 408
```

### 3.34 E-DCH scheduling - UE

Option: R&S SMBVB-K83

Access:

1. Select "3GPP FDD > User Equipment > link Direction > Uplink / Reverse > User Equipments > UE"
2. Select "E-DCH".

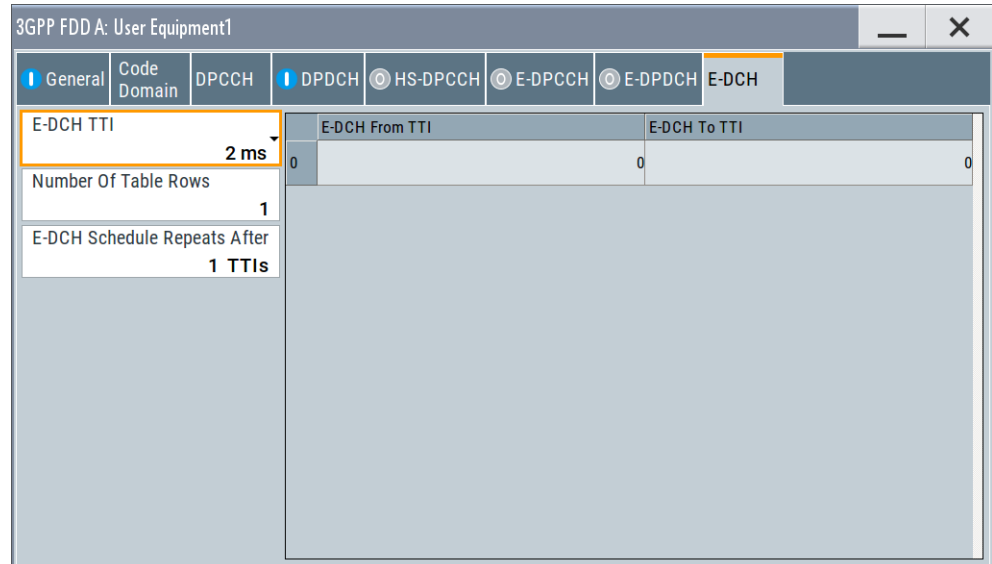

This dialog comprises the settings necessary to configure the common time schedule of the E-DPDCH and E-DPCCH. The settings enable you to configure single E-DCH packets or "bursts" of variable length consisting of several successive E-DCH packets and to decide upon the E-DCH packets distribution.

Use the [Scheduling list](#) to display and verify the configured uplink scheduling for every UE.



### Real time vs. ARB signal generation

The E-DCH channels are generated in real time or as an ARB signal.

- If the E-DCH channels are generated as ARB signal, the ARB sequence length has to be long enough and a multiple or equal the scheduling repetition.
- The instrument generates the channels in real time if [UL-DTX... / User Scheduling State](#) and/or [Dynamic Power Control State](#) is activated.
  - During generation of E-DCH channels in real-time, channel coding (i.e. activation of FRCs) is disabled. Use pre-channel-coded data list as "Data Source" if channel coded data on the E-DCH is required.
  - The E-DPDCH can be generated in realtime only for overall symbol rates with one E-DPDCH channel or those that restrict the E-DPDCHs to the I or Q branch.

### Example: E-DCH Scheduling

To configure an E-DCH transmission in TTIs 3-6, 128-156, 1003-1006, 1128-1156, etc. perform the settings listed in [Table 3-11](#).

**Table 3-11: E-DCH scheduling example**

Parameter	Value	Comment
Select "3GPP FDD > Filter/Clipping/ARB Settings" and adjust the <a href="#">Sequence Length ARB</a>	200 frames	If the E-DCH channels are generated as ARB signal, the ARB sequence length has to be long enough and a multiple or equal the scheduling repetition.
E-DCH TTI	2 ms	
<a href="#">Number of Table Rows</a>	2	two scheduled E-DCH bursts
<a href="#">E-DCH Schedule Repeats After</a>	1000 TTIs	each E-DCH burst is repeated every 1000 TTIs
Row#0		E-DCH burst (4 E-DCH packets)
"E-DCH TTI From"	3	
"E-DCH TTI To"	6	
Row#1		E-DCH burst (29 E-DCH packets)
"E-DCH TTI From"	128	
"E-DCH TTI To"	156	
<a href="#">E-DPCCH State</a>	On	Enables E-DPCCH
<a href="#">E-DPDCH State</a>	On	Enables E-DPDCH

Open the [Scheduling list](#) to display the E-DCH scheduling.

3GPP FDD: UE1/Scheduling List

Frame Start: 0      Number Of Frames: 10

|: The channel is inactive in the slot.  
X: The channel is active in the slot.  
\_\_: The channel restarts because of the ARB sequence length.

Frame Number:	Slot Number:	DPCCH Slots:	DPDCH Slots:	E-DCH TTI Number:	E-DPCCH Slots:	E-DPDCH Slots:
0	0	X	X	0		
	1	X	X			
	2	X	X			
	3	X	X	1		
	4	X	X			
	5	X	X			
	6	X	X	2		
	7	X	X			
	8	X	X			
	9	X	X	3	X	X
	10	X	X		X	X
	11	X	X		X	X
	12	X	X	4	X	X
	13	X	X		X	X
	14	X	X		X	X
1	0	X	X	5	X	X
	1	X	X		X	X
	2	X	X		X	X
	3	X	X	6	X	X
	4	X	X		X	X
	5	X	X		X	X
	6	X	X	7		
	7	X	X			
	8	X	X			
	9	X	X	8		
	10	X	X			
	11	X	X			
	12	X	X	9		
	13	X	X			
	14	X	X			

**E-DCH TTI**

Sets the size for the TTI (Transmission Time Interval).

If an [FRC](#) is set for the E-DPCCH or [UL-DTX...](#) / [User Scheduling State](#) is enabled, this field is read-only.

Remote command:

```
[ :SOURCE<hw> ] :BB:W3Gpp:MSTation<st>[:HSUPa]:EDCH:TTIEdch
on page 422
```

```
[ :SOURCE<hw> ] :BB:W3Gpp:MSTation<st>[:HSUPa]:DPDCh:E:TTIEdch
on page 422
```

**Number of Table Rows**

Sets the number of the rows in the scheduling table, i.e. determines the number of the E-DCH "bursts" enabled for configuration. An E-DCH "burst" is built of several successive E-DCH packets.

Remote command:

```
[ :SOURCE<hw> ] :BB:W3Gpp:MSTation<st>[:HSUPa]:EDCH:ROWCount
on page 423
```

**E-DCH Schedule Repeats After**

Determine the number of TTIs after that the E-DCH scheduling is repeated.

Remote command:

`[ :SOURCE<hw> ] :BB:W3GPP:MSTation<st> [ :HSUPa ] :EDCH:REPEAT`  
on page 422

#### **E-DCH Scheduling Table**

Enables flexible configuration of single E-DCH packets or E-DCH "bursts" of variable length consisting of several successive E-DCH packets

#### **E-DCH TTI From ← E-DCH Scheduling Table**

Determines the start TTI of the corresponding E-DCH burst.

Remote command:

`[ :SOURCE<hw> ] :BB:W3GPP:MSTation<st> [ :HSUPa ] :EDCH:ROW<ch0>:FROM`  
on page 423

#### **E-DCH TTI To ← E-DCH Scheduling Table**

Determines the end TTI of the corresponding E-DCH burst.

Remote command:

`[ :SOURCE<hw> ] :BB:W3GPP:MSTation<st> [ :HSUPa ] :EDCH:ROW<ch0>:TO`  
on page 423

### 3.35 Global enhanced channel settings - UE1



"Global Enhanced Channel" settings are only available for user equipment 1 (UE1).

Access:

1. Select "3GPP FDD > Link Direction > Uplink / Reverse > User Equipments > UE 1".
2. Select "DPDCH Settings > Global Enhanced Channels...".

### 3.35.1 Enhanced channels state

Access:

- ▶ Select "Enhanced".

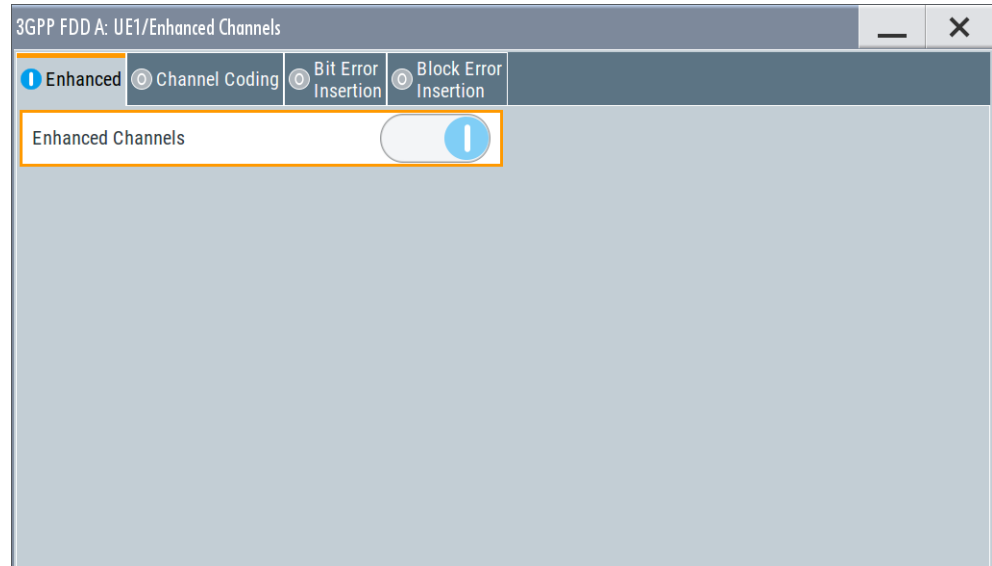

In this tab, you can activate the global enhanced settings.

#### Enhanced Channels State

Displays the enhanced state of the station. As at least the DPCCH of UE1 is always calculated in real time, the enhanced state is always on for UE1.

The DPCCH and one DPDCH of user equipment 1 are generated in real time. Depending on the actual configurations, other channels of user equipment 1 can also be generated in real time.

It is possible to activate channel coding and simulate bit and block errors. Data lists, for example with user data for the transport layer, can be used as the data source.

Remote command:

`[ :SOURCE<hw> ] :BB:W3GPp:MSTation:ENHanced:DPDCh:STATe` on page 437

### 3.35.2 Channel coding

Access:

1. Select "3GPP FDD > Link Direction > Uplink / Reverse > User Equipments > UE 1".
2. Select "DPDCH Settings > Global Enhanced Channels...".

## 3. Select "Channel Coding"

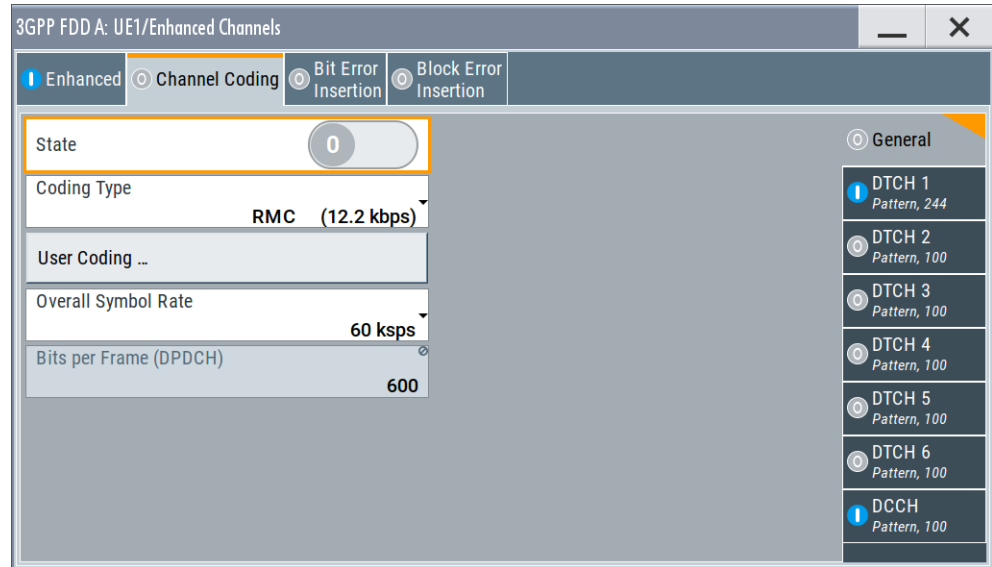

The "Channel Coding > General" tab comprises the settings for enabling and configuring the channel coding. The provided settings are divided into general settings and several subtabs, one per transport channel.

To access the channel coding settings of a transport channel, select the corresponding side tab, for example "DTCH1". Refer to [Chapter 3.35.3, "Transport channel"](#), on page 218 for description of the provided settings.

According to 3GPP TS 25.141, an uplink reference measurement channel is generated when the transport channels DTCH and DCCH are mapped to a DPDCH with a different data rate. The mapping is performed after channel coding and multiplexing. [Figure 3-22](#) illustrates the generation of a 12.2 kbps reference measurement channel from the DTCH and DCCH transport channels.

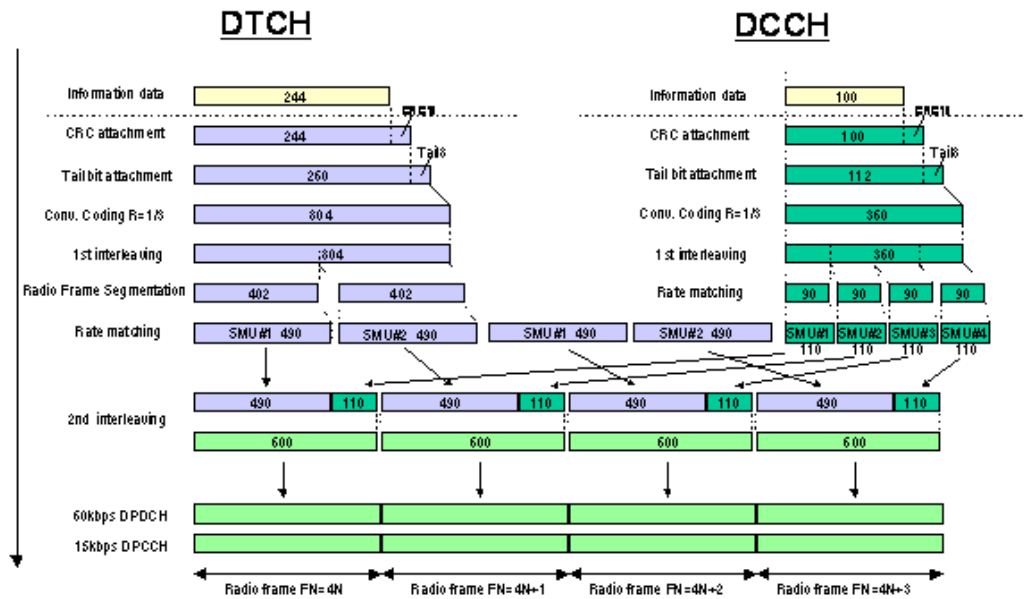

Figure 3-22: Channel coding of the 12.2 kbps reference measurement channels (uplink) [3GPP TS 25.141]

### Channel Coding State

Activates or deactivates channel coding.

**Note:** Annex A.1, 3GPP TS 25.141, lists the recommended DPCCH-settings.

Remote command:

`[ :SOURCE<hw> ] :BB:W3GPP:MSTation:ENHanced:DPDCh:CCODing:STAtE`

on page 432

### Coding Type

Selects channel coding.

The 3GPP specification defines 4 reference measurement channel coding types, which differ in the input data bit rate to be processed (12.2, 64, 144 and 384 kbps). The additional AMR CODER coding scheme generates the coding of a voice channel.

"User" coding can be defined as required in the detailed coding settings menu section revealed with button "Show Details". They can be stored and loaded in the "User Coding" submenu. Selection "User" is indicated as soon as a coding parameter is modified after selecting a predefined coding type.

The input data bits are taken from the data source specified for the "Transport Channels" for channel coding. The bits are available with a higher rate at the channel coding output. The allocations between the measurement input data bit rate and the output symbol rate are fixed, that is to say, the overall symbol rate is adjusted automatically.

The following are available for selection:

"RMC 12.2      12.2 kbps measurement channel  
kbps"

"RMC 64 kbps" 64 kbps measurement channel



"RMC 144        144 kbps measurement channel  
kbps"  
"RMC 384        384 kbps measurement channel  
kbps"  
"AMR 12.2       Channel coding for the AMR coder  
kbps"

Remote command:

`[ :SOURCE<hw> ] :BB:W3GPP:MSTation:ENHanced:DPDCh:CCODing:TYPE`  
on page 432

### User Coding ...

Accesses files with user codings and the standard "File Select" function.

User codings of UE1 are stored as files with the predefined file extension  
\*.3g\_ccod\_ul. The filename and the directory they are stored in are user-definable;  
the file extension is assigned automatically.

The complete channel coding settings are saved and recalled.

Remote command:

`[ :SOURCE<hw> ] :BB:W3GPP:MSTation:ENHanced:DPDCh:CCODing:USER:`  
`CATalog?` on page 433

`[ :SOURCE<hw> ] :BB:W3GPP:MSTation:ENHanced:DPDCh:CCODing:USER:`  
`DELeTe` on page 433

`[ :SOURCE<hw> ] :BB:W3GPP:MSTation:ENHanced:DPDCh:CCODing:USER:LOAD`  
on page 434

`[ :SOURCE<hw> ] :BB:W3GPP:MSTation:ENHanced:DPDCh:CCODing:USER:`  
`STORe` on page 434

### Overall Symbol Rate

Sets the overall symbol rate of the DPDCH.

The structure of the DPDCH channel table depends on this parameter. The overall  
symbol rate determines which DPDCHs are active, which symbol rate they have and  
which channelization codes they use.

DPDCHs that are not active by virtue of the overall rate, are also disabled for opera-  
tion.

**Note:** Up to an overall rate of 960 ksps, only DPDCH 1 is active. Its symbol rate is the  
same as the overall rate and the channelization code is the same as spreading factor/4  
(spreading factor = chip rate / symbol rate).

With an overall symbol rate greater than 960 ksps, all the active DPDCHs have the  
symbol rate 960 ksps.

Remote command:

`[ :SOURCE<hw> ] :BB:W3GPP:MSTation:ENHanced:DPDCh:ORATe` on page 437

### Bits per Frame (DPDCH)

Displays the data bits in the DPDCH component of the frame at physical level. The  
value depends on the overall symbol rate.

Remote command:

`[ :SOURCE<hw> ] :BB:W3GPP:MSTation:ENHanced:DPDCh:BPFrame?`

on page 431

### 3.35.3 Transport channel

Access:

1. Select "3GPP FDD > Link Direction > Uplink / Reverse > User Equipments > UE 1".
2. Select "DPDCH Settings > Global Enhanced Channels... > Channel Coding".
3. Select the corresponding side tab, for example "DTCH1".

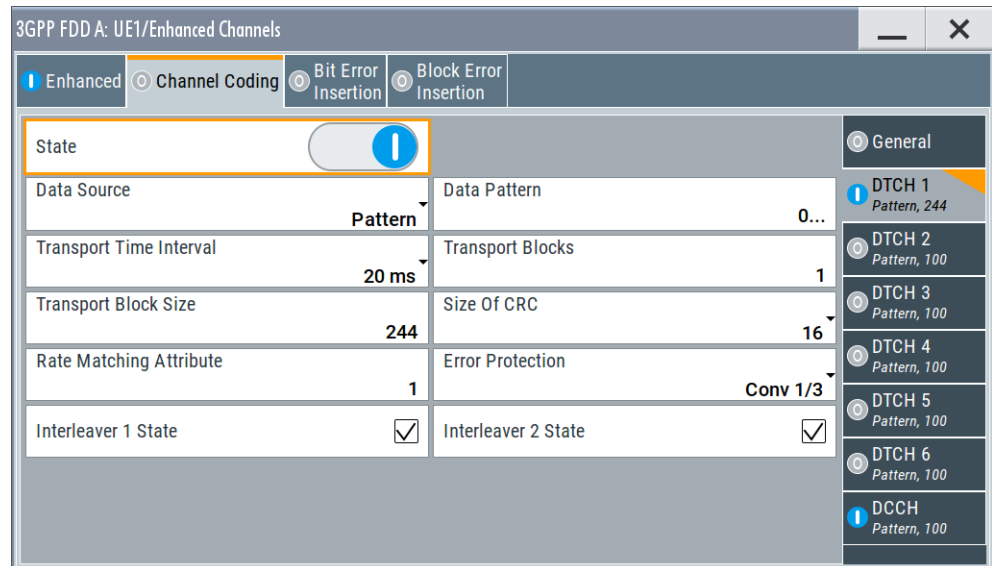

The dialog provides access to the settings of up to seven transport channels (TCHs), the DTCHs (DTCH1 to 6) and the DCCH.

#### Transport Channel State

Activates or deactivates the transport channel.

Remote command:

`[ :SOURCE<hw> ] :BB:W3GPP:MSTation:ENHanced:DPDCh:TChannel<di0>:STATE` on page 438

In case of remote control, DCCH corresponds to `:TChannel10`, DTCH1 to `:TChannel11`, etc.

#### Data Source

Selects the data source for the transport channel.

The data source for the DCCH and DTCH1 can also be selected in the main dialog in the channel table.

The following standard data sources are available:

- "All 0, All 1"  
An internally generated sequence containing 0 data or 1 data.
- "PNxx"  
An internally generated pseudo-random noise sequence.
- "Pattern"  
An internally generated sequence according to a bit pattern.  
Use the "Pattern" box to define the bit pattern.
- "Data List/Select DList"  
A binary data from a data list, internally or externally generated.  
Select "Select DList" to access the standard "Select List" dialog.
  - Select the "Select Data List > navigate to the list file \*.dm\_iqd > Select" to select an existing data list.
  - Use the "New" and "Edit" functions to create internally new data list or to edit an existing one.
  - Use the standard "File Manager" function to transfer external data lists to the instrument.

See also:

- Section "Modulation Data" in the R&S SMBV100B user manual.
- Section "File and Data Management" in the R&S SMBV100B user manual.
- Section "Data List Editor" in the R&S SMBV100B user manual

Remote command:

`[ :SOURce<hw> ] :BB:W3GPp:MSTation:ENHanced:DPDCh:TCHannel<di0>:DATA` on page 439

`[ :SOURce<hw> ] :BB:W3GPp:MSTation:ENHanced:DPDCh:TCHannel<di0>:DATA:PATtern` on page 440

`[ :SOURce<hw> ] :BB:W3GPp:MSTation:ENHanced:DPDCh:TCHannel<di0>:DATA:DSElect` on page 440

### Transport Time Interval

Sets the number of frames into which a TCH is divided. This setting also defines the interleaver depth.

Remote command:

`[ :SOURce<hw> ] :BB:W3GPp:MSTation:ENHanced:DPDCh:TCHannel<di0>:TTINterval` on page 439

### Number of Transport Blocks

Sets the number of transport blocks for the TCH.

Remote command:

`[ :SOURce<hw> ] :BB:W3GPp:MSTation:ENHanced:DPDCh:TCHannel<di0>:TBCount` on page 438

### Transport Block Size

Sets the size of the transport block at the channel coding input.

Remote command:

`[ :SOURce<hw> ] :BB:W3GPp:MSTation:ENHanced:DPDCh:TCHannel<di0>:TBSize` on page 438

**Size of CRC**

Defines the type (length) of the CRC. Checksum determination can also be deactivated (setting "None").

Remote command:

```
[ :SOURce<hw> ] :BB:W3GPP:MSTation:ENHanced:DPDCh:TCHannel<di0>:
CRCSize on page 439
```

**Rate Matching Attribute**

Sets data rate matching.

Remote command:

```
[ :SOURce<hw> ] :BB:W3GPP:MSTation:ENHanced:DPDCh:TCHannel<di0>:
RMAtribute on page 437
```

**Error Protection**

Selects error protection.

- |                  |  |
|------------------|--|
| "None"           | No error protection  |
| "Turbo 1/3"      | Turbo coder of rate 1/3 in accordance with the 3GPP specifications.              |
| "Conv 1/2   1/3" | Convolution coder of rate 1/2 or 1/3 with generator polynomials defined by 3GPP. |

Remote command:

```
[ :SOURce<hw> ] :BB:W3GPP:MSTation:ENHanced:DPDCh:TCHannel<di0>:
EProtection on page 441
```

**Interleaver 1 State**

Activates or deactivates channel coding interleaver state 1 of the transport channel. Interleaver state 1 can be set independently in each TCH. Activation does not change the symbol rate.

Remote command:

```
[ :SOURce<hw> ] :BB:W3GPP:MSTation:ENHanced:DPDCh:TCHannel<di0>:
INterleaver on page 441
```

**Interleaver 2 State**

Activates or deactivates channel coding interleaver state 2 of all the transport channels. Interleaver state 2 can only be set for all the TCHs together. Activation does not change the symbol rate.

Remote command:

```
[ :SOURce<hw> ] :BB:W3GPP:MSTation:ENHanced:DPDCh:INterleaver2
on page 436
```

### 3.35.4 Error insertion

Access:

1. Select "3GPP FDD > Link Direction > Uplink / Reverse > User Equipments > UE 1".
2. Select "DPDCH Settings > Global Enhanced Channels...".
3. Select "Bit Error Insertion / Block Error Insertion".

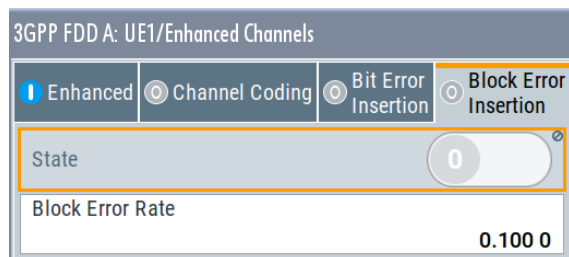
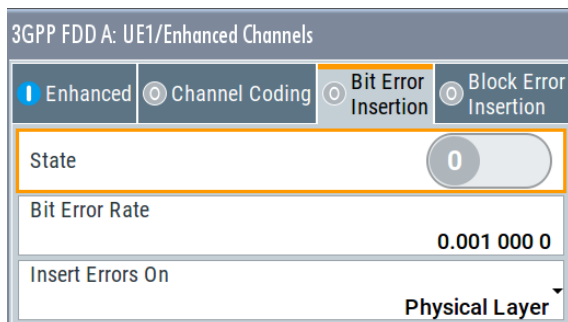

The dialogs provide the parameters for inserting errors into the data source and into the CRC checksum, for example, to check the bit and block error rate testers.

#### Bit Error State

Activates or deactivates bit error generation.

Bit errors are inserted into the data fields of the enhanced channels. When channel coding is active, it is possible to select the layer in which the errors are inserted (physical or transport layer).

When the data source is read out, individual bits are deliberately inverted at random points in the data bitstream at the specified error rate so that invalid signal is simulated.

Remote command:

`[ :SOURCE<hw> ] :BB:W3GPp:MSTation:ENHanced:DPDCh:DERRor:BIT:STATE`  
on page 435

#### Bit Error Rate TCH1

Sets the bit error rate.

Remote command:

`[ :SOURCE<hw> ] :BB:W3GPp:MSTation:ENHanced:DPDCh:DERRor:BIT:RATE`  
on page 435

#### Insert Errors On

Selects the layer at which bit errors are inserted.

"Transport layer"	Bit errors are inserted in the transport layer. This layer is only available when channel coding is active.
-------------------	--

"Physical layer" Bit errors are inserted in the physical layer.

Remote command:

`[ :SOURCE<hw> ] :BB:W3GPP:MSTation:ENHanced:DPDCh:DERRor:BIT:LAYer`  
on page 435

#### Block Error State

Activates or deactivates block error generation.

The CRC checksum is determined and then the last bit is inverted at the specified error probability in order to simulate an invalid signal.

Block error generation is only available when channel coding is active.

Remote command:

`[ :SOURCE<hw> ] :BB:W3GPP:MSTation:ENHanced:DPDCh:DERRor:BIT:STATE`  
on page 435

#### Block Error Rate

Sets the block error rate.

Remote command:

`[ :SOURCE<hw> ] :BB:W3GPP:MSTation:ENHanced:DPDCh:DERRor:BLOCK:RATE`  
on page 436

## 3.36 PRACH settings - UE

Access:

1. Select "3GPP FDD > Link Direction > Uplink / Reverse > User Equipments > UE 1".
2. Select "Mode > PRACH Standard/PRACH Preamble Only".

The PRACH settings are available in two modes:

- In "Standard" mode, the instrument generates a single physical random access channel (PRACH). This channel is used during the connection set up between the user equipment and the base station.

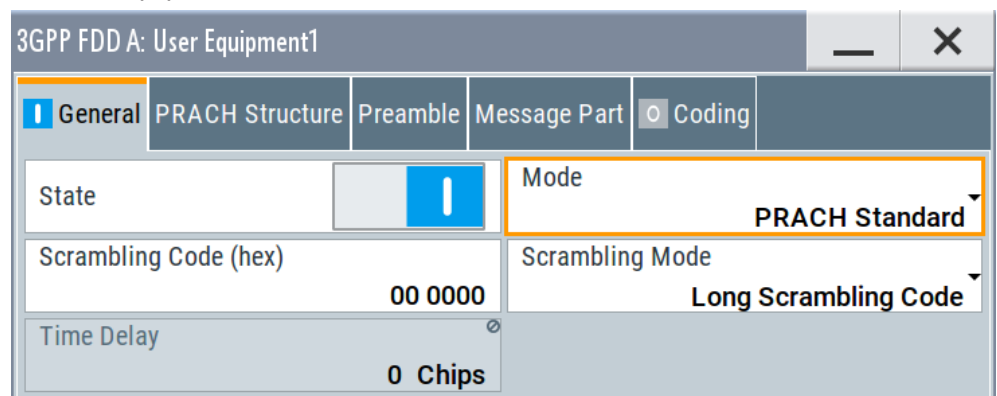

- In "Preamble only" mode, the instrument only generates the preamble of a physical random access channel (PRACH). This mode is required for test case 8.8, according to 3GPP TS 25.141.

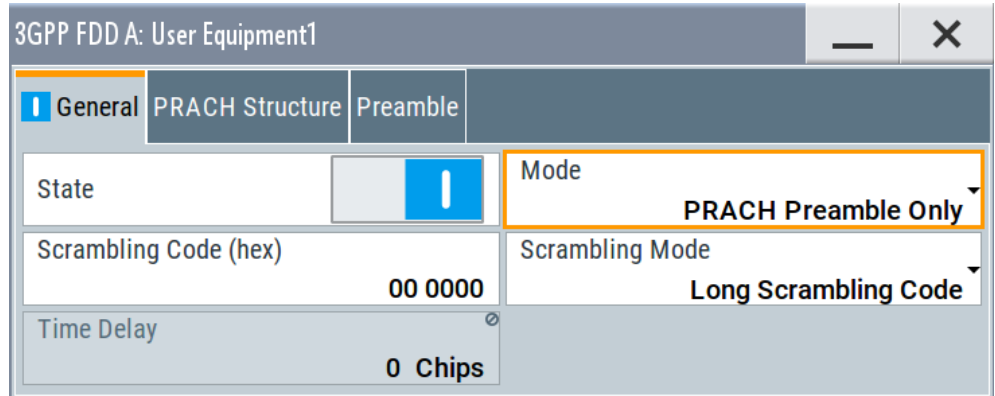

In this mode, only the preamble parameters are available.

3. Select "PRACH Structure".

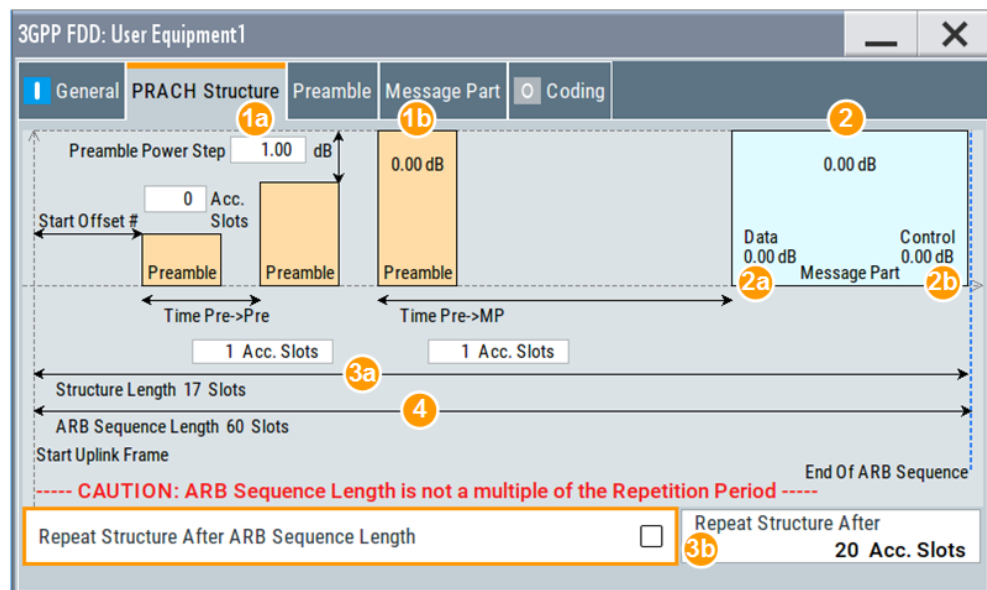

**Figure 3-23: Standard PRACH Structure: Understanding the displayed information**

- 1a = "Preamble Power Step"; subtract this value from 1b to calculate the power of the other preambles
- 1b = "Delta Power (Preamble)", i.e. correction value for the last preamble before the message part
- 2 = "Delta Power (Message Part)", i.e. correction value for the message part overall
- 2a, 2b = Correction values for the data and control part of the message part
- 3a = Current "Structure Length"
- 3b = User-defined repetition of the PRACH structure, i.e. the same structure is repeated three times within the current ARB sequence length
- 4 = Current ARB sequence length (in slots); set with the parameter [Sequence Length ARB](#)

The dialog comprises a graphical representation of the PRACH structure, including the timing parameters, the "Preamble Settings" and "Message Part" sections. The last sections comprise the preamble settings for the parameters of the data part of the channel. Some settings are made directly in the input fields of the graphical display.

In the "Channel Coding" section, channel coding can be activated.

### Power settings and power calculation

- Calculating the power of the preamble  
The correction value for the last preamble before the message part (indication in the preamble block) is indicated in the graphical display of the PRACH structure. The power of the other preambles is calculated by subtracting the selected "Preamble Power Step".
- Calculating the power of the message part  
The correction values for the message part overall and separately for data and control part (indications in the message part block) are also indicated. For one active UE and if the "Level Reference" is set to "RMS Power", the RF power of the message part is calculated as:  
"Message Part Power" = "RF Level" + "Delta Power Message Part"

#### Example: Calculating the power of the message part

- "3GPP > User Equipment > Level Reference > RMS Power"
- "Level = 5 dBm"
- "Delta Power Message Part = 5.79 dB"

The resulting "Message Part Power" = 5 + 5.79 = 10.79 dBm

## 3.36.1 Graphical display

The graphical display shows either the complete PRACH including the message part or only the preamble depending on the selected mode.

### PRACH standard

1. To access these settings, select "3GPP FDD > Link Direction > Uplink / Reverse > User Equipments > UE 1".
2. Select "Mode > PRACH Standard".
3. Select "PRACH Structure".  
See [Figure 3-23](#)

### PRACH Preamble Only

1. In the "General" tab, select "Mode > PRACH Preamble Only"



2. Select "PRACH Structure".

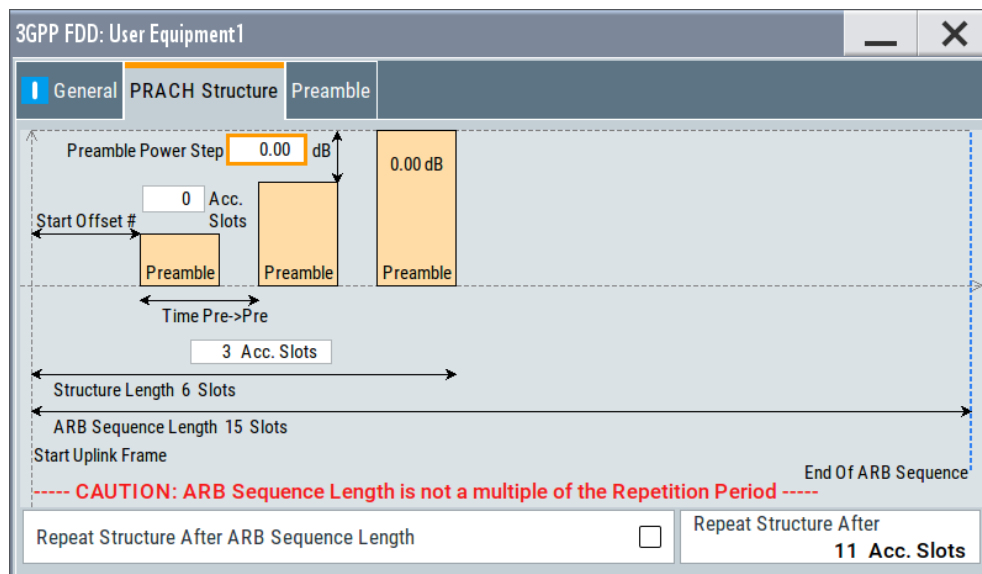

Figure 3-24: PRACH mode Preamble Only

Some of the parameter values can be input directly in the input fields of the graphical display. The indicated structure length and the power correction values match the real settings; the number of preambles, however, is shown as an example, to explain the parameter function.

Use the power correction values to calculate the correct settings for the desired RF level, see "[Power settings and power calculation](#)" on page 224.

#### Delta Power (Preamble)

Indicates the level correction value for the last preamble before the message part.

The level of the other preambles can be calculated by subtracting the set "Preamble Power Step".

Remote command:

```
[ :SOURCE<hw> ] :BB:W3Gpp:MSTation<st>:PRACH:TIMing:DPOWER:PREamble? on page 404
```

#### Delta Power (Message Part)

Indicates the level correction value for the message part, together with the power offsets of the data and control part.

The indication of the total value is important for measurements where just the envelope of the signal is of interest whereas the separate indication is useful for receiver tests.

See also "[Power settings and power calculation](#)" on page 224.

Remote command:

`[ :SOURce<hw> ] :BB:W3GPp:MSTation<st>:PRACH:TIMing:DPOWer:MPART?`  
on page 403

`[ :SOURce<hw> ] :BB:W3GPp:MSTation<st>:PRACH:TIMing:DPOWer:MPART:DATA?` on page 404

`[ :SOURce<hw> ] :BB:W3GPp:MSTation<st>:PRACH:TIMing:DPOWer:MPART:CONTrol?` on page 404

### Start Offset #

Enters the start offset of the PRACH in access slots or slots.

The starting time delay in timeslots is then equal to  $2 \times \text{Start Offset \#}$

Remote command:

`[ :SOURce<hw> ] :BB:W3GPp:MSTation<st>:PRACH:TIMing:SOFFset`  
on page 405

### Time Pre->Pre

Enters the time difference between two successive preambles in access slots.

Remote command:

`[ :SOURce<hw> ] :BB:W3GPp:MSTation<st>:PRACH:TIMing:TIME:PREPre`  
on page 406

### Time Pre->MP

Enters the time difference between the last preamble and the message part in access slots.

Two modes are defined in the standard. In mode 0, the preamble to message part difference is 3 access slots, in mode 1 it is 4 access slots.

Remote command:

`[ :SOURce<hw> ] :BB:W3GPp:MSTation<st>:PRACH:TIMing:TIME:PREMp`  
on page 405

### Structure Length

Indicates the structure length:

- In "PRACH only - Preamble" mode, the structure length is defined as:  
"Structure Length" = "Start Offset (Slots)" + "Preamble Repetition" \* "Time Pre->Pre"

#### Example: Calculating the structure length in PRACH preamble only mode

"Start Offset # = 1 Access Slots", i.e. two slots

"Preamble Repetition = 2"

"Time Pre->Pre = 2 Access Slots", i.e. four slots

"Structure Length" = 2 Slots + 2 x 4 Slots = 10 Slots

- In "PRACH only - Standard" mode, the structure length is defined as:  
"Structure Length" = "Start Offset (Slots)" + "Preamble Repetition" \* "Time Pre->Pre" + "Time Pre->MP" + 15 \* "Message Part Length (Frames)"

**Example: Calculating the structure length in PRACH Standard mode**

"Start Offset # = 2 Access Slots", i.e. four slots

"Preamble Repetition = 3"

"Time Pre->Pre = Time Pre->MP = 3 Access Slots", i.e. six slots

"Message Part Length = 2 Frames"

"Structure Length" = 4 Slots + 2 x 6 Slots + 6 Slots + 15 x 2 = 52 Slots

See also "[Repeat Structure After ARB Sequence Length](#)" on page 227.

Remote command:

`[ :SOURCE<hw> ] :BB:W3GPP:MSTation<st>:PRACH:TIMing:SPERiod?`  
on page 405

**ARB Sequence Length**

Indicates the ARB sequence length.

**Note:** A caution message is displayed, if the structure length is longer than the selected ARB sequence length.

To change the ARB sequence length, use the parameter [Sequence Length ARB](#).

Remote command:

`[ :SOURCE<hw> ] :BB:W3GPP:SLENgth` on page 262

**Repeat Structure After ARB Sequence Length**

Enables/disables repeating the selected PRACH structure during one ARB sequence.

"On"

Within one ARB sequence, the selected PRACH structure is repeated once.

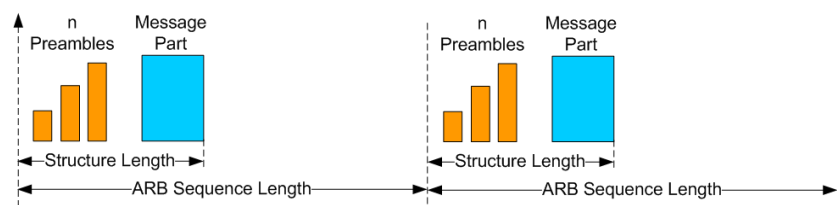

**Figure 3-25: "Repeat Structure after ARB sequence length = On"**

"Off"

The selected PRACH structure can be repeated several times, depending on the structure length and the [Repeat Structure After \(x Acc. Slots\)](#).

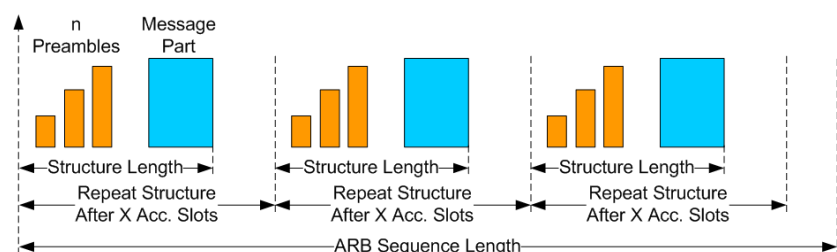

**Figure 3-26: "Repeat Structure after ARB sequence length = Off"**

Remote command:

`[ :SOURCE<hw> ] :BB:W3GPp:MSTation<st>:PRACH:RARb` on page 401

#### Repeat Structure After (x Acc. Slots)

If "Repeat Structure After ARB Sequence Length > Off", sets the number of access slots after that the selected PRACH structure is repeated, see [Figure 3-26](#).

Remote command:

`[ :SOURCE<hw> ] :BB:W3GPp:MSTation<st>:PRACH:RAFTer` on page 401

### 3.36.2 Preamble settings

1. To access these settings, select "3GPP FDD > Link Direction > Uplink / Reverse > User Equipments > UE 1".
2. Select "Mode > PRACH Standard/PRACH Preamble Only".
3. Select "Preamble".

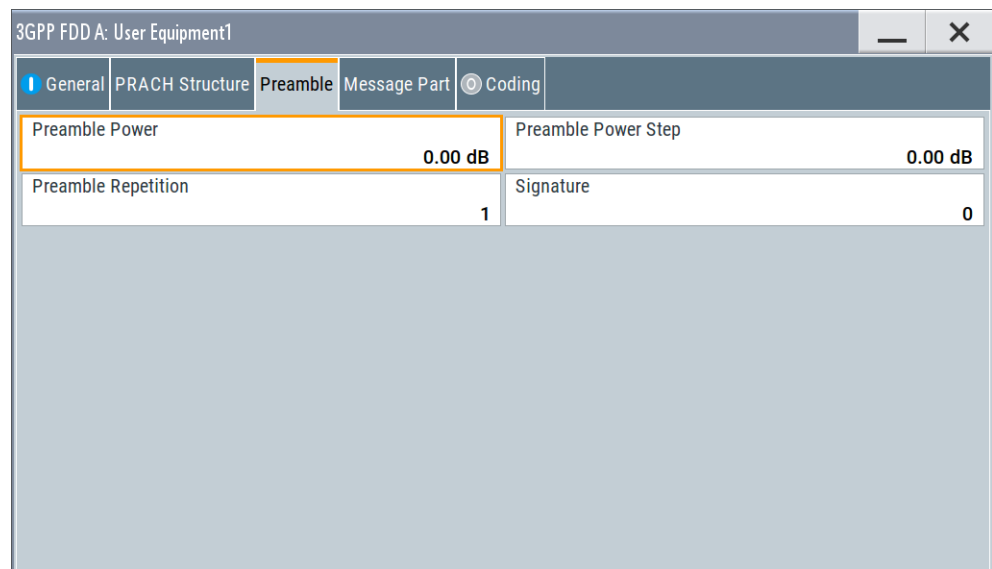

The dialog comprises the parameters for configuring the PRACH preamble.

#### Preamble Power

Sets the power of the preamble component of the PRACH channel.

Remote command:

`[ :SOURCE<hw> ] :BB:W3GPp:MSTation<st>:PRACH:PPower` on page 400

#### Preamble Power Step

Sets the power by which the preamble is increased from repetition to repetition. The power set with the parameter [Preamble Power](#) is the "target power", used during the last repetition of the preamble.

**Example:**

"Preamble Power = 0 dB"

"Preamble Repetition = 3"

"Preamble Power Step = 3 dB"

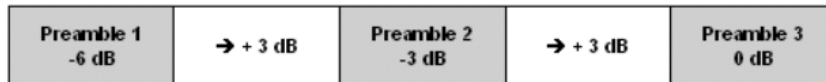

*Figure 3-27: Generated power sequence*

Remote command:

[\[:SOURCE<hw>\]:BB:W3GPP:MSTation<st>:PRACH:PPOWER:STEP](#) on page 400

**Preamble Repetition**

Sets the preamble count.

Remote command:

[\[:SOURCE<hw>\]:BB:W3GPP:MSTation<st>:PRACH:PREpetition](#) on page 401

**Signature**

Selects the signature to be used for the PRACH channel.

The signature defines the code domain for the channelization code being used. 16 fixed bit patterns are defined.

Remote command:

[\[:SOURCE<hw>\]:BB:W3GPP:MSTation<st>:PRACH:SIGNature](#) on page 402

**3.36.3 Message part settings**

Access:

1. Select "3GPP FDD > Link Direction > Uplink / Reverse > User Equipments > UE 1".
2. Select "Mode > PRACH Standard".

## 3. Select "Message Part".

3GPP FDD A: User Equipment1				
General	PRACH Structure	Preamble	Message Part	Coding
Data Power	0.00 dB	Control Power	0.00 dB	
Message Length	1 Frames	Slot Format #	1	
Symbol Rate	30 ksps	TFCI	0	
Data Source	Pattern	Data Pattern (bin)	0...	

The tab comprises the settings for the data part of the PRACH.

**Data Power**

Sets the power of the data component of the PRACH channel.

Remote command:

[\[:SOURCE<hw>\]:BB:W3GPp:MSTation<st>:PRACH:DPOWER](#) on page 399

**Control Power**

Sets the power of the control component of the PRACH channel.

Remote command:

[\[:SOURCE<hw>\]:BB:W3GPp:MSTation<st>:PRACH:CPOWER](#) on page 398

**Message Length**

Sets the length of the message component of the PRACH channel in frames.

Remote command:

[\[:SOURCE<hw>\]:BB:W3GPp:MSTation<st>:PRACH:MLENGTH](#) on page 400

**Slot Format**

Selects the slot format.

Slot formats 0 to 3 are available for the PRACH channel. The slot format defines the symbol rate of the message component.

Remote command:

[\[:SOURCE<hw>\]:BB:W3GPp:MSTation<st>:PRACH:SFORmat](#) on page 402

**Symbol Rate**

Sets the symbol rate of the PRACH channel.

The symbol rate is determined by the slot format set. A change in the symbol rate leads automatically to an adjustment of the slot format.

Remote command:

[\[:SOURCE<hw>\]:BB:W3GPP:MSTation<st>:PRACH:SRATE](#) on page 402

### TFCI

Enters the value of the TFCI field (transport format combination indicator) in the control component of the PRACH channel.

Remote command:

[\[:SOURCE<hw>\]:BB:W3GPP:MSTation<st>:PRACH:TFCI](#) on page 403

### Data Source

Selects the data source for the data component of the PRACH channel.

The following standard data sources are available:

- "All 0, All 1"  
An internally generated sequence containing 0 data or 1 data.
- "PNxx"  
An internally generated pseudo-random noise sequence.
- "Pattern"  
An internally generated sequence according to a bit pattern.  
Use the "Pattern" box to define the bit pattern.
- "Data List/Select DList"  
A binary data from a data list, internally or externally generated.  
Select "Select DList" to access the standard "Select List" dialog.
  - Select the "Select Data List > navigate to the list file \*.dm\_iqd > Select" to select an existing data list.
  - Use the "New" and "Edit" functions to create internally new data list or to edit an existing one.
  - Use the standard "File Manager" function to transfer external data lists to the instrument.

See also:

- Section "Modulation Data" in the R&S SMBV100B user manual.
- Section "File and Data Management" in the R&S SMBV100B user manual.
- Section "Data List Editor" in the R&S SMBV100B user manual

Remote command:

[\[:SOURCE<hw>\]:BB:W3GPP:MSTation<st>:PRACH:DATA](#) on page 398

[\[:SOURCE<hw>\]:BB:W3GPP:MSTation<st>:PRACH:DATA:PATtern](#) on page 399

[\[:SOURCE<hw>\]:BB:W3GPP:MSTation<st>:PRACH:DATA:DSElect](#) on page 399

## 3.36.4 Channel coding state

Channel coding of PRACH is possible for all UEs.

1. To access these settings, select "3GPP FDD > Link Direction > Uplink / Reverse > User Equipments > UE 1".
2. Select "Mode > PRACH Standard".

## 3. Select "Coding".

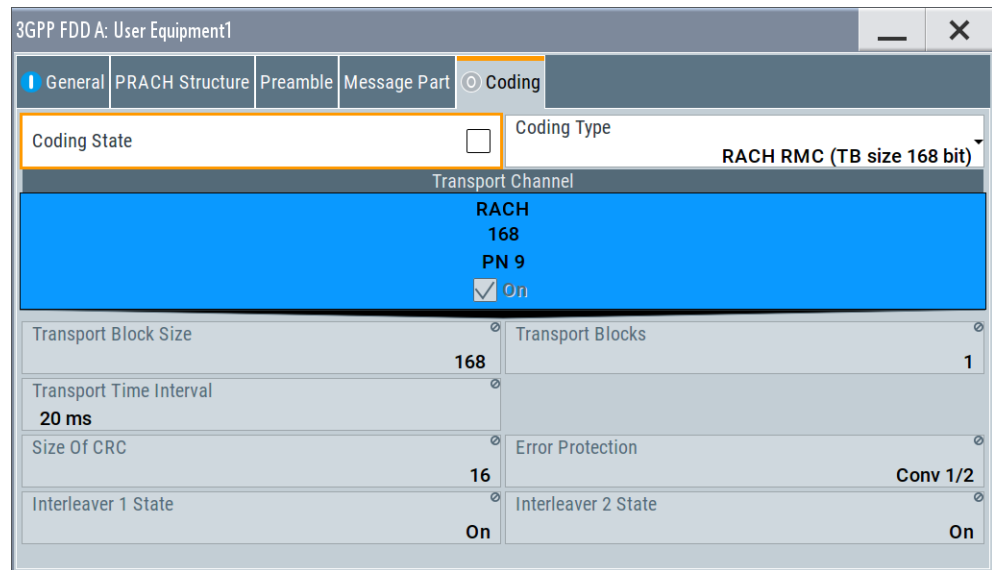

The tab comprises the parameters defining the coding type and activating the PRACH channel. The fixed settings for the channel coding parameters are displayed.

**Coding State**

Activates or deactivates channel coding for the PRACH channel.

If enabled, the "Message Part Length" automatically is set to 2. It cannot be changed.

Remote command:

`[ :SOURCE<hw> ] :BB:W3Gpp:MSTation<st>:ENHanced:PRACH:CCODing:STATE`  
on page 442

**Coding Type**

Selects the predefined reference measurement channel coding types for the PRACH channel.

"RACH RMC (TB size 168 bit)"

Reference Measurements Channel Coding with transport block size of 168 bit.

"RACH RMC (TB size 360 bit)"

Reference Measurements Channel Coding with transport block size of 360 bit.

Remote command:

`[ :SOURCE<hw> ] :BB:W3Gpp:MSTation<st>:ENHanced:PRACH:CCODing:TYPE`  
on page 442

**Show Coding**

Calls the menu for displaying the channel coding settings. The reference measurement channel parameters are set to fixed values.

The following parameters are displayed:



- "Data Source" The data source is displayed in the transport channel graphical display.
- "Transport Block Size" Size of the transport block at the channel coding input.
- "Transport Block" Transport block count.
- "Transport Time Interval" Number of frames into which a TCH is divided.
- "Size of CRC" CRC type (length).
- "Error Protection" Error protection.
- "Interleaver 1 / 2 State" Channel coding interleaver state
- Remote command:  
n.a.

### 3.37 PCPCH settings - UE

Access:

1. Select "3GPP FDD > Link Direction > Uplink / Reverse > User Equipments > UE 1".
2. Select "Mode > PCPCH Standard/PCPCH Preamble Only".

The PCPCH settings are available in two modes:

- In "PCPCH Standard" mode, the instrument generates a single physical common packet channel (PCPCH). This channel is used to transmit packet-oriented services (e.g. SMS).

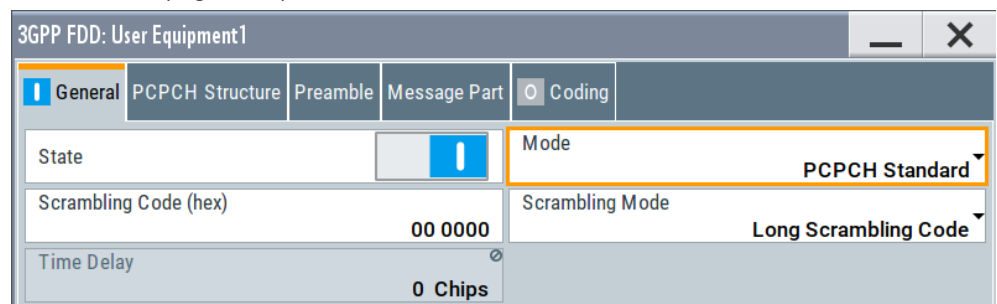

- In "PCPCH Preamble only" mode, the instrument only generates the preamble of a physical common packet channel (PCPCH). This mode is needed for test case 8.9, according to 3GPP TS 25.141.

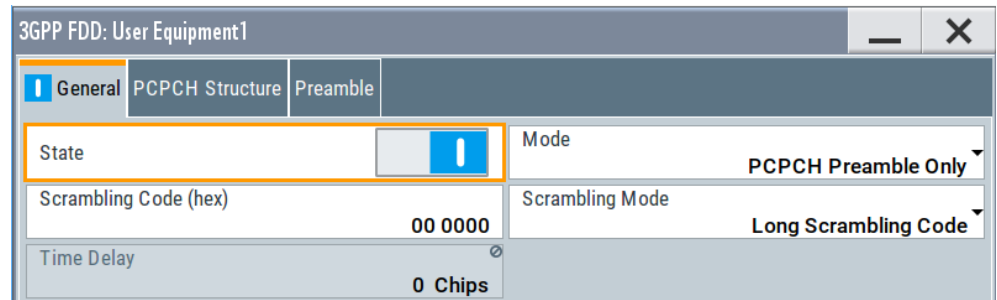

In this mode, only the preamble parameters are available.

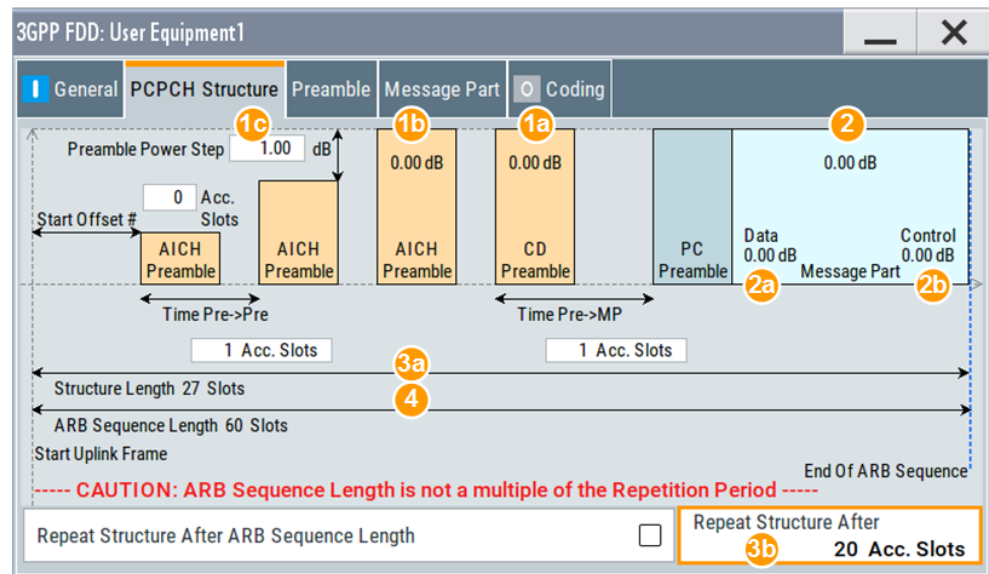

**Figure 3-28: Standard PCPCH Structure: Understanding the displayed information**

- 1a, 1b = "Delta Power (Preamble)", i.e. correction values for the last AICH preamble before the message part and the CD Preamble
- 1c = "Preamble Power Step"; subtract this value from 1b to calculate the power of the other preambles
- 2 = "Delta Power (Message Part)", i.e. correction value for the message part overall
- 2a, 2b = Correction values for the data and control part of the message part
- 3a = Current "Structure Length"
- 3b = User-defined repetition of the PCPCH structure, i.e. the same structure is repeated three times within the current ARB sequence length
- 4 = Current ARB sequence length (in slots); set with the parameter [Sequence Length ARB](#)

The dialog comprises a graphical display of the PCPCH structure including the timing parameters, the "Preamble Settings" and "Message Part" sections. The last sections comprise the preamble settings and the parameters for the data part of the channel. Some settings are made directly in the input fields of the graphical display.

The "Channel Coding" settings for activating channel coding are available for UE1.

### Power settings and power calculation

- Calculating the power of the preamble  
The graphical display of the PCPCH structure indicates:

- The correction value for the last AICH preamble before the message part
- The CD Preamble (indication in the AICH and CD Preamble block)

The power of the other preambles is calculated by subtracting the selected "Preamble Power Step".

- Calculating the power of the message part  
The power correction value of the message part is indicated in the message part settings.  
For one active UE, the RF power of the message part is calculated as:  
"Message Part Power" = "RF Level" + "Delta Power Message Part"  
For PCPCH, the parameter "Level Reference" is always "RMS Power".

**Example: Calculating the power of the message part**

- "Level = 5 dBm"
- "Delta Power Message Part = 5.58 dB"

The resulting "Message Part Power" = 5 + 5.58 = 10.58 dBm

### 3.37.1 Graphical display

The graphical display shows either the complete PCPCH including the message part or only the preamble depending on the selected mode.

**PCPCH Standard**

1. To access these settings, select "3GPP FDD > Link Direction > Uplink / Reverse > User Equipments > UE 1".
2. Select "Mode > PCPCH Standard"
3. Select "PCPCH Structure".  
See [Figure 3-28](#)

**PCPCH preamble-only**

1. In the "General" tab, select "Mode > PCPCH Preamble Only"

2. Select "PCPCH Structure".

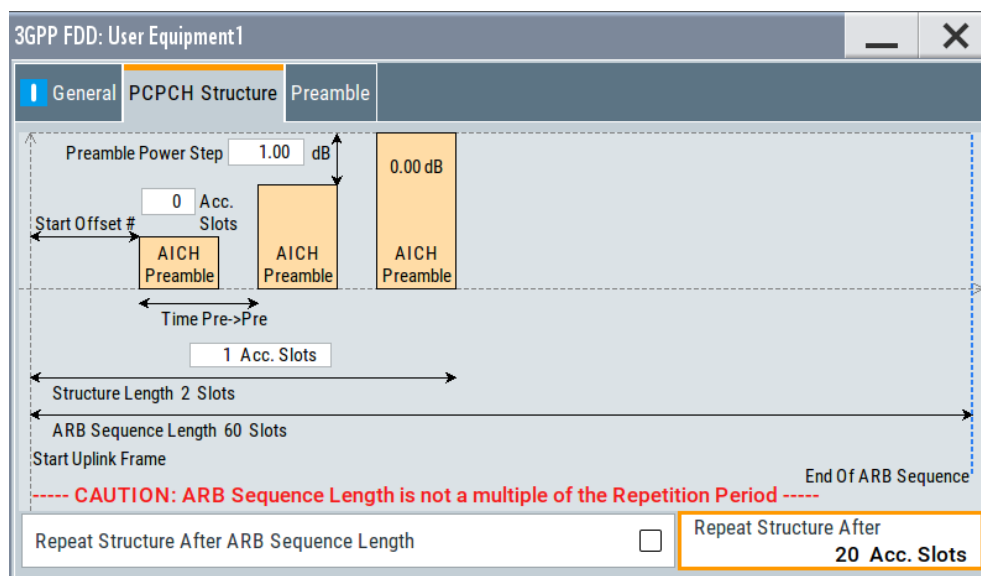

Figure 3-29: PCPCH Structure in "Mode > PCPCH preamble-only"

Some of the parameter values can be input directly in the input fields of the graphical display. The indicated structure length and the power correction values match the real settings; the number of preambles, however, is shown as an example, to explain the parameter function.

Use the power correction values to calculate the correct settings for the desired RF level (see "Power settings and power calculation" on page 234).

#### Delta Power (Preamble)

Indication of the level correction value for the last AICH preamble before the message part. This value is identical to the correction value for the CD preamble.

The level of the other preambles can be calculated by subtracting the set "Preamble Power Step".

Remote command:

`[ :SOURce<hw> ] :BB:W3GPp:MSTation<st>:PCPCh:TIMing:DPOWer:PREamble?` on page 393

#### Delta Power (Message Part)

Indicates the level correction value for the message part, together with the power offsets of the data and control part.

See also [Example"Calculating the power of the message part"](#) on page 235.

Remote command:

`[ :SOURce<hw> ] :BB:W3GPp:MSTation<st>:PCPCh:TIMing:DPOWer:MPART?` on page 393

#### Start Offset #

Enters the start offset of the PCPCH in access slots.

**Note:** The PCPCH only transmitted once, at the start of the sequence.

The starting time delay in timeslots is calculated according to TS 25 211, chapter 7.3 PCPCH/AICH timing relation and is  $2 \times \text{Start Offset \#}$ .

Remote command:

```
[ :SOURCE<hw> ] :BB:W3GPP:MSTation<st>:PCPCh:TIMing:SOFFset
```

on page 394

#### Transmission Timing (Preamble)

Enters the time difference between two successive preambles in access slots.

Remote command:

```
[ :SOURCE<hw> ] :BB:W3GPP:MSTation<st>:PCPCh:TIMing:TIME:PREPre
```

on page 395

#### Transmission Timing (Message Part)

Enters the time difference between the last preamble and the message part in access slots.

Two modes are defined in the standard. In mode AICH transmission timing 0, the preamble to message part difference is three access slots. In mode AICH transmission timing 1, it is four access slots.

Remote command:

```
[ :SOURCE<hw> ] :BB:W3GPP:MSTation<st>:PCPCh:TIMing:TIME:PREMp
```

on page 394

#### Structure Length

Indicates the structure length:

- In "PCPCH only - Preamble" mode, the structure length is defined as:  
"Structure Length" = "Start Offset (Slots)" + "Preamble Repetition" \* "Time Pre->Pre"

#### Example: Calculating the structure length in PCPCH preamble-only mode

"Start Offset # = 2 access slots", i.e. = 4 slots

"Preamble Repetition = 2"

"Time Pre->Pre = 2 access slots", i.e. = 4 slots

"Structure Length" = 4 slots + 2 x 4 slots = 12 slots

- In "PCPCH only - Standard" mode, the structure length is defined as:  
"Structure Length" = "Start Offset (Slots)" + "Preamble Repetition" \* "Time Pre->Pre" + "Time Pre->MP" + "Power Control Preamble Length" + 15 \* "Message Part Length (Frames)"  
In PCPCH mode, the CD preamble has to be accounted. Therefore, preamble repetition instead of (preamble repetition - 1) is used.

**Example: Calculating the structure length in PCPCH Standard mode**

"Start Offset = 2 access slots", i.e. four slots

"Preamble Repetition = 3"

"Time Pre - Pre = Time Pre - MP = 3 access slots", i.e. six slots

"Power Control Preamble Length = 8 slots"

"Message Part Length = 2 frames"

"Structure Length" = 4 slots + 3 x 6 slots + 6 slots + 8 + 15 x 2 = 66 slots

Remote command:

`[ :SOURCE<hw> ] :BB:W3GPP:MSTation<st>:PCPCh:TIMing:SPERiod?`  
on page 394

**ARB Sequence Length**

Indication of the ARB sequence length.

**Note:** A caution message is displayed, if the structure length is longer than the selected ARB sequence length.

To change the ARB sequence length, use the parameter [Sequence Length ARB](#).

Remote command:

`[ :SOURCE<hw> ] :BB:W3GPP:SLENgth` on page 262

**Repeat Structure After ARB Sequence Length**

Enables/disables repeating the selected PCPCH structure during one ARB sequence.

"On"                      Within one ARB sequence, the selected PCPCH structure is repeated once.  
See [Figure 3-25](#) for illustration of the principle.

"Off"                      The selected PCPCH structure can be repeated several times, depending on the structure length and the [Repeat Structure After \(x Acc. Slots\)](#).  
See [Figure 3-26](#) for illustration of the principle.

Remote command:

`[ :SOURCE<hw> ] :BB:W3GPP:MSTation<st>:PCPCh:RARB` on page 391

**Repeat Structure After (x Acc. Slots)**

If "Repeat Structure After ARB Sequence Length > Off", sets the number of access slots after that the selected PCPCH structure is repeated, see [Figure 3-26](#).

Remote command:

`[ :SOURCE<hw> ] :BB:W3GPP:MSTation<st>:PCPCh:RAFTer` on page 391

**3.37.2 Preamble settings**

1. To access these settings, select "3GPP FDD > Link Direction > Uplink / Reverse > User Equipments > UE 1".

2. Select "Mode > PCPCH Standard/PCPCH Preamble Only".

3GPP FDD A: User Equipment1				
General	PCPCH Structure	<b>Preamble</b>	Message Part	Coding
Preamble Power	0.00 dB		Preamble Power Step	0.00 dB
Preamble Repetition	1		Power Control Preamble Length	8 Slots
Signature	0			

The dialog comprises the parameters for configuring the PCPCH preamble.

#### Preamble Power

Sets the power of the preamble component of the PCPCH channel.

Remote command:

[\[:SOURCE<hw>\]:BB:W3GPp:MSTation<st>:PCPCh:PPower](#) on page 390

#### Preamble Repetition

Sets the preamble count.

Remote command:

[\[:SOURCE<hw>\]:BB:W3GPp:MSTation<st>:PCPCh:PREpetition](#) on page 391

#### Preamble Power Step

Sets the power by which the preamble is increased from repetition to repetition. The power set under Preamble Power is the "target power", used during the last repetition of the preamble.

#### Example:

"Preamble Power" = 0 dB

"Preamble Repetition" = 3

"Preamble Power Step" = 3 dB

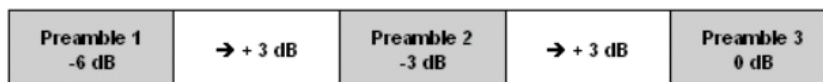

Figure 3-30: Generated power sequence

Remote command:

[\[:SOURCE<hw>\]:BB:W3GPp:MSTation<st>:PCPCh:PPower:STEP](#) on page 390

**Power Control Preamble Length**

Sets the length of the power control preamble in slots.

Remote command:

[\[:SOURCE<hw>\]:BB:W3GPP:MSTation<st>:PCPCh:PLENgtH](#) on page 390

**Signature**

Selects the signature to be used for the PCPCH channel. The signature defines the code domain for the channelization code being used.

Remote command:

[\[:SOURCE<hw>\]:BB:W3GPP:MSTation<st>:PCPCh:SIGNature](#) on page 392

**3.37.3 Message part settings**

Access:

1. Select "3GPP FDD > Link Direction > Uplink / Reverse > User Equipments > UE 1".
2. Select "Mode > PCPCH Standard".
3. Select "Message Part".

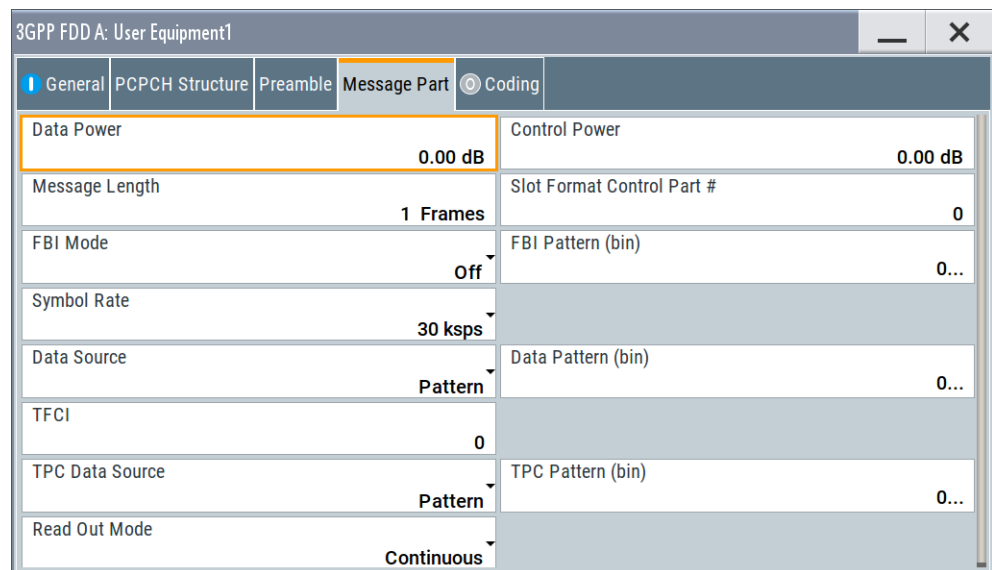

The tab comprises the settings for the data part of the PCPCH.

**Data Power**

Sets the power of the data component of the PCPCH channel.

Remote command:

[\[:SOURCE<hw>\]:BB:W3GPP:MSTation<st>:PCPCh:DPOWer](#) on page 388

**Control Power**

Sets the power of the control component of the PCPCH channel.



Remote command:

`[ :SOURCE<hw> ] :BB:W3GPP:MSTation<st>:PCPCh:CPOWer` on page 386

### Message Length

Sets the length of the message component of the PCPCH channel in frames.

Remote command:

`[ :SOURCE<hw> ] :BB:W3GPP:MSTation<st>:PCPCh:MLENgtH` on page 389

### Slot Format

Selects the slot format of the control component of the PCPCH channel.

Slot formats 0 to 2 are available for the PCPCH channel. The slot format defines the structure of the control component, the FBI mode.

When channel coding is active, the FBI mode and the slot format are prescribed.

"Slot format 0" No FBI field

"Slot format 1" 1 FBI field

"Slot format 2" 2 FBI fields

Remote command:

`[ :SOURCE<hw> ] :BB:W3GPP:MSTation<st>:PCPCh:CPSFormat` on page 387

### FBI Mode

Selects the FBI (feedback information) mode.

The FBI mode is determined by the slot format set. A change in the FBI mode leads automatically to an adjustment of the slot format.

"FBI Off" The FBI field is not in use.

"FBI On 1 Bit" The FBI field is used with a length of 1 bit.

"FBI On 2 Bits" The FBI field is used with a length of 2 bits.

Remote command:

`[ :SOURCE<hw> ] :BB:W3GPP:MSTation<st>:PCPCh:FBI:MODE` on page 389

### FBI Pattern

Enters the bit pattern for the FBI field in the control part (of the message part) of the PCPCH.

The FBI field is filled cyclically with a pattern of up to 32 bits in length.

Remote command:

`[ :SOURCE<hw> ] :BB:W3GPP:MSTation<st>:PCPCh:FBI:PATTern` on page 389

### Symbol Rate

Sets the symbol rate of the PCPCH channel.

The symbol rate is determined by the slot format set. A change in the symbol rate leads automatically to an adjustment of the slot format.

When channel coding is active, the symbol rate is prescribed.

Remote command:

`[ :SOURCE<hw> ] :BB:W3GPP:MSTation<st>:PCPCh:SRATe` on page 392

**Data Source**

Selects the data source for the data component of the PCPCH channel.

The following standard data sources are available:

- "All 0, All 1"  
An internally generated sequence containing 0 data or 1 data.
- "PNxx"  
An internally generated pseudo-random noise sequence.
- "Pattern"  
An internally generated sequence according to a bit pattern.  
Use the "Pattern" box to define the bit pattern.
- "Data List/Select DList"  
A binary data from a data list, internally or externally generated.  
Select "Select DList" to access the standard "Select List" dialog.
  - Select the "Select Data List > navigate to the list file \*.dm\_iqd > Select" to select an existing data list.
  - Use the "New" and "Edit" functions to create internally new data list or to edit an existing one.
  - Use the standard "File Manager" function to transfer external data lists to the instrument.

See also:

- Section "Modulation Data" in the R&S SMBV100B user manual.
- Section "File and Data Management" in the R&S SMBV100B user manual.
- Section "Data List Editor" in the R&S SMBV100B user manual

Remote command:

[\[:SOURCE<hw>\]:BB:W3GPP:MSTation<st>:PCPCh:DATA](#) on page 387

[\[:SOURCE<hw>\]:BB:W3GPP:MSTation<st>:PCPCh:DATA:PATtern](#) on page 388

[\[:SOURCE<hw>\]:BB:W3GPP:MSTation<st>:PCPCh:DATA:DSElect](#) on page 388

**TFCI**

Enters the value of the TFCI field (transport format combination indicator) in the control component of the PCPCH channel.

Remote command:

[\[:SOURCE<hw>\]:BB:W3GPP:MSTation<st>:PCPCh:TFCI](#) on page 393

**TPC Data Source**

Defines the data source for the TPC field of the PCPCH channel.

The following standard data sources are available:

- "All 0, All 1"  
An internally generated sequence containing 0 data or 1 data.
- "Pattern"  
An internally generated sequence according to a bit pattern.  
Use the "Pattern" box to define the bit pattern.
- "Data List/Select TPC Data List"  
A binary data from a data list, internally or externally generated.  
Select "Select DList" to access the standard "Select List" dialog.
  - Select the "Select Data List > navigate to the list file \*.dm\_iqd > Select" to select an existing data list.

- Use the "New" and "Edit" functions to create internally new data list or to edit an existing one.
- Use the standard "File Manager" function to transfer external data lists to the instrument.

See also:

- Section "Modulation Data" in the R&S SMBV100B user manual.
- Section "File and Data Management" in the R&S SMBV100B user manual.
- Section "Data List Editor" in the R&S SMBV100B user manual.

Remote command:

`[ :SOURce<hw> ] :BB:W3GPp:MSTation<st>:PCPCh:TPC:DATA` on page 395

`[ :SOURce<hw> ] :BB:W3GPp:MSTation<st>:PCPCh:TPC:DATA:DSElect`  
on page 395

`[ :SOURce<hw> ] :BB:W3GPp:MSTation<st>:PCPCh:TPC:DATA:PATtern`  
on page 396

### Read Out Mode

Defines TPC data usage.

The TPC bits are used to signal the increase or reduction in transmit power to the called station. For all read out modes, 1 bit is taken from the data stream for the TPC field for each slot. The bit is entered into the bitstream several times, depending on the symbol rate. The difference between the modes lies in the usage of the TPC bits.

The different modes can be used to set a specific output power and then let the power oscillate around this value. For example, if the power is the pattern 11111, the power can be varied with "Single + alt. 01" and "Single + alt. 10". Thus, power measurements can be carried out at quasi-constant power.

- "Continuous:"  
The TPC bits are used cyclically.
- "Single + All 0"  
The TPC bits are used once, and then the TPC sequence is continued with 0 bits.
- "Single + All 1"  
The TPC bits are used once, and then the TPC sequence is continued with 1 bit.
- "Single + alt. 01"  
The TPC bits are used once and then the TPC sequence is continued with 0 bits and 1 bit alternately. Bits as appended in multiples, depending on the symbol rate, for example, 00001111.
- "Single + alt. 10"  
The TPC bits are used once and then the TPC sequence is continued with 1 bit and 0 bits alternately. Bits as appended in multiples, depending on by the symbol rate, for example, 11110000.

Remote command:

`[ :SOURce<hw> ] :BB:W3GPp:MSTation<st>:PCPCh:TPC:READ` on page 396

### 3.37.4 Channel coding settings

Access:

1. Select "3GPP FDD > Link Direction > Uplink / Reverse > User Equipments > UE 1".
2. Select "Mode > PCPCH Standard".

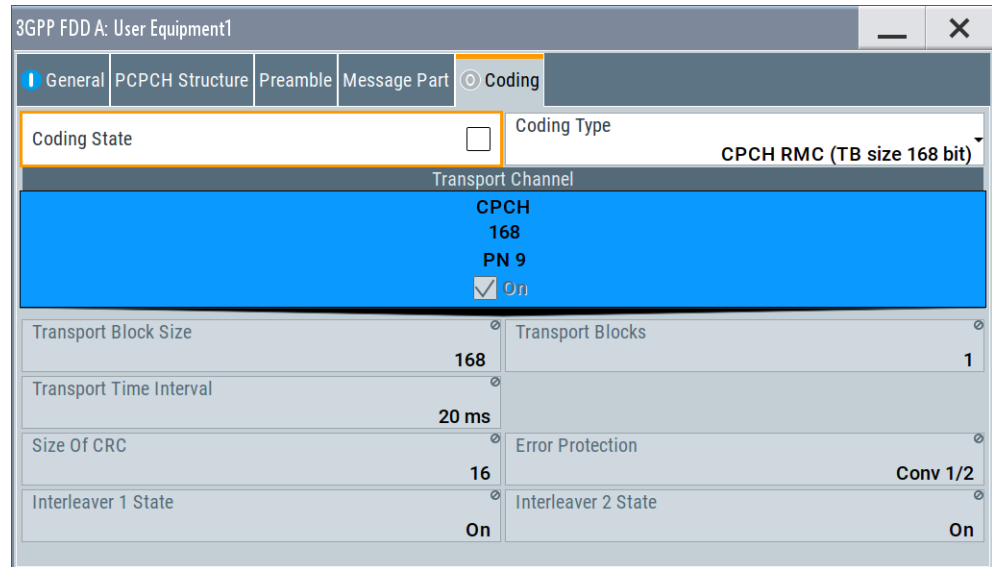

The tab comprises the parameters defining the coding type and activating the PCPCH channel. The fixed settings for the channel coding parameters are displayed.

#### Channel Coding State

Activates or deactivates channel coding for the PCPCH channel.

Remote command:

`[ :SOURCE<hw> ] :BB:W3GPP:MSTation:ENHanced:PCPCh:CCODing:STATE`  
on page 441

#### Channel Coding Type

Selects the predefined reference measurement channel coding types for the PCPCH channel.

"CPCH RMC (TB size 168 bit)"

Reference Measurements Channel Coding with transport block size of 168 bit.

"CPCH RMC (TB size 360 bit)"

Reference Measurements Channel Coding with transport block size of 360 bit.

Remote command:

`[ :SOURCE<hw> ] :BB:W3GPP:MSTation:ENHanced:PCPCh:CCODing:TYPE`  
on page 442

**Show Coding**

Calls the menu for displaying channel coding. The reference measurement channel parameters are set to fixed values.

The following parameters are displayed:

"Data Source" The data source is displayed in the transport channel graphical display.

"Transport Block Size"  
Size of the transport block at the channel coding input.

"Transport Block"  
Transport blocks count.

"Transport Time Interval"  
Number of frames into which a TCH is divided.

"Size of CRC" CRC type (length).

"Error Protection"  
Error protection.

"Interleaver 1 / 2 State"  
Channel coding interleaver state

Remote command:

n.a.

### 3.38 Filtering, clipping, ARB settings

Access:

- ▶ Select "3GPP FDD > General > Filter/Clipping/ARB Settings".

The dialog comprises the settings, necessary to configure the baseband filter, to enable clipping and adjust the sequence length of the arbitrary waveform component.

### 3.38.1 Filter settings

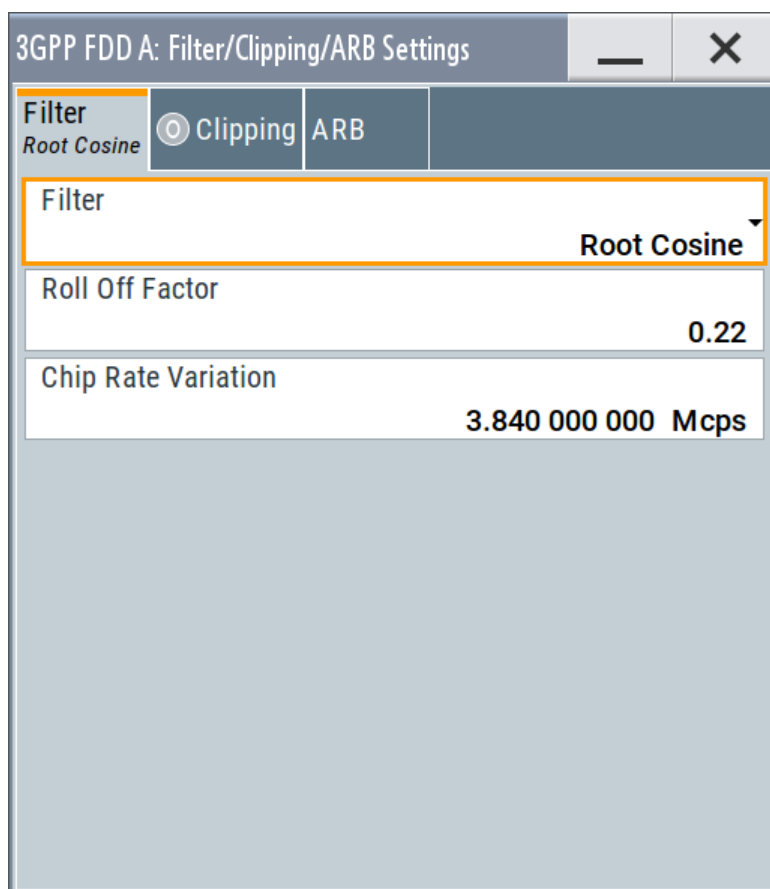

#### Settings:

##### Filter

Selects the baseband filter.

Remote command:

`[ :SOURce<hw> ] :BB:W3GPp:FILTer:TYPE` on page 270

##### Roll Off Factor or BxT

Sets the filter parameter.

The filter parameter offered ("Roll Off Factor" or "BxT") depends on the currently selected filter type. This parameter is preset to the default for each of the predefined filters.

Remote command:

`[ :SOURce<hw> ] :BB:W3GPp:FILTer:PARAMeter:APCO25` on page 268

`[ :SOURce<hw> ] :BB:W3GPp:FILTer:PARAMeter:COsine` on page 268

`[ :SOURce<hw> ] :BB:W3GPp:FILTer:PARAMeter:GAUSS` on page 268

`[ :SOURce<hw> ] :BB:W3GPp:FILTer:PARAMeter:RCOSine` on page 269

`[ :SOURce<hw> ] :BB:W3GPp:FILTer:PARAMeter:SPHase` on page 270

**Cut Off Frequency Factor**

Sets the value for the cut-off frequency factor. The cut-off frequency of the filter can be adjusted to reach spectrum mask requirements.

Remote command:

[\[:SOURce<hw>\]:BB:W3GPp:FILTer:PARAmeter:LPASs](#) on page 269

[\[:SOURce<hw>\]:BB:W3GPp:FILTer:PARAmeter:LPASSEVM](#) on page 269

**Chip Rate Variation**

Enters the chip rate. The default settings for the chip rate are 3.84 Mcps.

The chip rate entry changes the output clock and the modulation bandwidth, as well as the synchronization signals that are output. It does not affect the calculated chip sequence.

Remote command:

[\[:SOURce<hw>\]:BB:W3GPp:CRATe:VARiation](#) on page 268

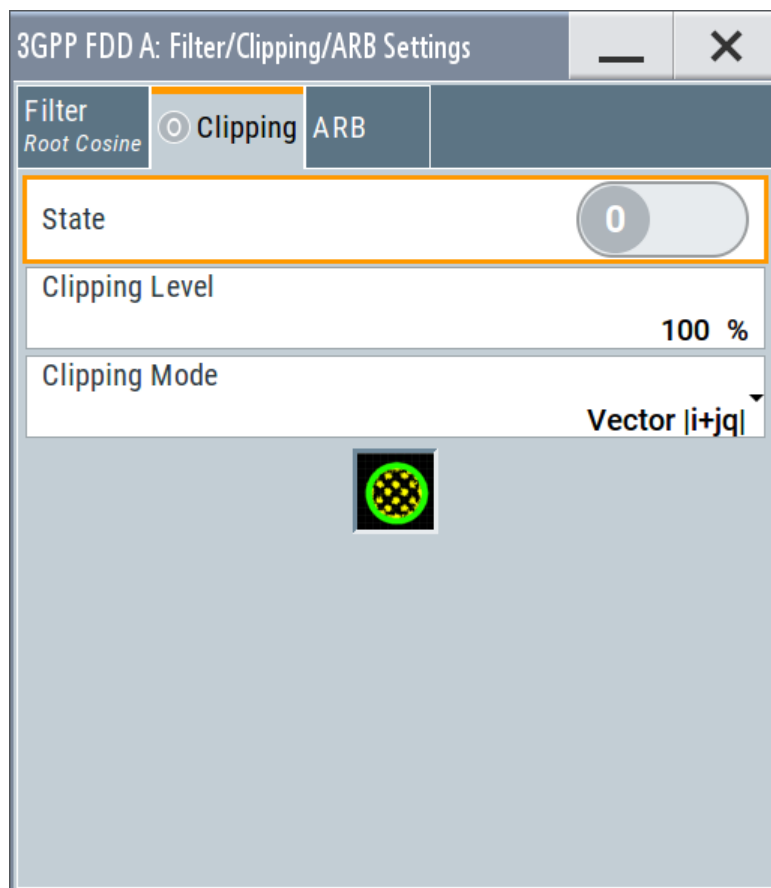
**3.38.2 Clipping settings**

Provided are the following settings:

**Clipping State**

Switches baseband clipping on and off.

Baseband clipping is a simple and effective way of reducing the crest factor of the WCDMA signal.

WCDMA signals can have high crest factors particularly with many channels and unfavorable timing offsets. High crest factors entail two basic problems:

- The nonlinearity of the power amplifier (compression) causes intermodulation which expands the spectrum (spectral regrowth).
- Since the level in the D/A converter is relative to the maximum value, the average value is converted with a relatively low resolution. This results in a high quantization noise.

Both effects increase the adjacent-channel power.

With baseband clipping, all the levels are limited to a settable value ("Clipping Level"). This level is specified as a percentage of the highest peak value. Since clipping is done before filtering, the procedure does not influence the spectrum. The EVM however increases.

Since clipping the signal not only changes the peak value but also the average value, the effect on the crest factor is unpredictable. The following example shows the effect of the "Clipping" on the crest factor for typical scenarios.

#### Example: Clipping effect on the crest factor

The [Table 3-12](#) shows changing the crest factor by clipping (vector mode  $|I+q|$ ) for signal configurations with different output crest factors.

100% clipping levels mean that clipping does not take place.

**Table 3-12: Crest factor values as function of the vector clipping**

Clipping level	Downlink: 10 DPCHs "Minimum Crest" 30 ksps	Downlink: 10 DPCHs "Worst Crest" 30 ksps	Downlink: 10 DPCHs "Average Crest" 30 ksps	Downlink: 128 DPCHs "Average Crest" 30 ksps
100%	9.89 dB	14.7 dB	10.9 dB	21.7 dB
80%	8.86 dB	12.9 dB	9.39 dB	20.2 dB
50%	7.50 dB	10.1 dB	8.29 dB	16.9 dB
20%	5.50 dB	6.47 dB	6.23 dB	12.5 dB
10%	5.34 dB	6.06 dB	5.80 dB	9.57 dB
5%	5.34 dB	6.06 dB	5.80 dB	8.17 dB

The pictures in the following table demonstrate the effect of clipping with vector mode ( $|I+q|$ ), using a signal configuration with 4 DPCH as an example.

The arrows and the circle in the upper illustration show how the levels are mapped during subsequent clipping in vector mode ( $|I+q|$ ).



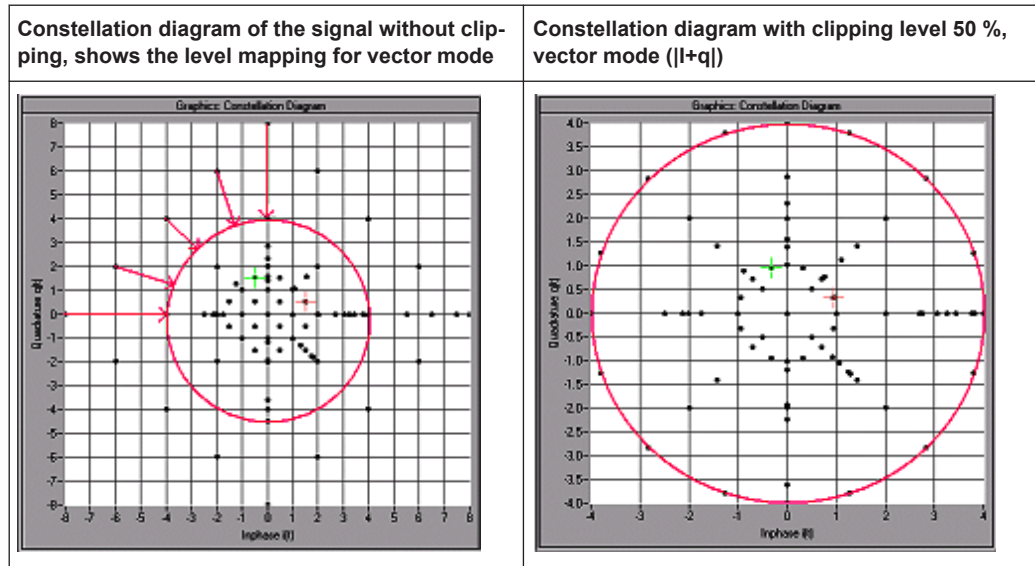

Remote command:

[\[:SOURCE<hw>\]:BB:W3GPp:CLIPping:STATE](#) on page 267

### Clipping Level

Sets the limit for clipping.

This value indicates at what point the signal is clipped. It is specified as a percentage, relative to the highest level. 100% indicates that clipping does not take place.

Remote command:

[\[:SOURCE<hw>\]:BB:W3GPp:CLIPping:LEVel](#) on page 266

### Clipping Mode

Selects the clipping method. The dialog displays a graphical illustration on how this two methods work.

- "Vector  $|i + jq|$ "  
The limit is related to the amplitude  $|i + jq|$ . The I and Q components are mapped together, the angle is retained.
- "Scalar  $|i|, |q|$ "  
The limit is related to the absolute maximum of all the I and Q values  $|i| + |q|$ . The I and Q components are mapped separately, the angle changes.

Remote command:

[\[:SOURCE<hw>\]:BB:W3GPp:CLIPping:MODE](#) on page 267

### 3.38.3 ARB settings

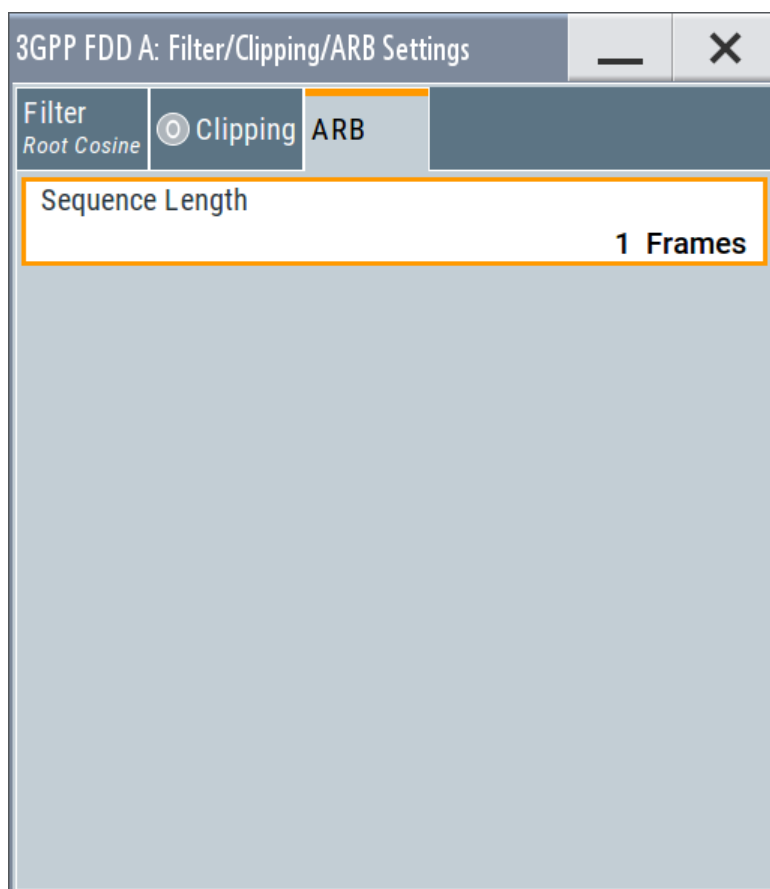

Provided are the following settings:

#### Sequence Length ARB

Changes the sequence length of the arbitrary waveform component of the signal. This component is calculated in advance and output in the arbitrary waveform generator. It is added to the realtime signal components.

The maximum number of frames is calculated as follows:

Max. No. of Frames = Arbitrary waveform memory size/(3.84 Mcps x 10 ms).

**Tip:** In pure amplifier tests with several channels and no enhanced channels, it is possible to improve the statistical properties of the signal by increasing the sequence length.

Remote command:

`[ :SOURce<hw> ] :BB:W3GPp:SENgth` on page 262

## 4 How to work with the 3GPP FDD option

The following step-by-step instructions demonstrate how to perform some signal generation tasks with the 3GPP FDD option.

### 4.1 Resolving domain conflicts

#### To resolve code domain conflicts

1. To recognize a downlink domain conflict, use one of the following methods:

a) Select "3GPP FDD > Base Station > Channel Table"

A conflict (warning) symbol in the tab name and in the channel table indicates a domain conflict.

The term domain conflict describes that channels overlap.

The screenshot shows the '3GPP FDD: Basestation1' window. The 'Channel Table' tab is active, indicated by a yellow warning icon. Below the tabs are buttons for 'Multi Channel Assistant ...', 'Reset All Channels', and 'Preset To HSDPA H-Set'. The main area displays a table with columns for Channel Type, Enh/HSDPA Settings, Slot Fmt, Sym Rate /ksps, Chan Code, Power /dB, Data, DList Patt, T Offs, DPCCH Settings, State, and Dom Conf. The table lists channels 7 through 14. Channel 9 (PDSCH) has a yellow warning icon in the Dom Conf column. Channel 10 (DL-DPCCH) has a yellow warning icon in the Dom Conf column. Channel 11 (DPCH) has a yellow warning icon in the Dom Conf column. Channel 12 (HS-SCCH) has a yellow warning icon in the Dom Conf column. Channel 13 (HS-PDS.QPSK) has a yellow warning icon in the Dom Conf column. Channel 14 (DPCH) has a yellow warning icon in the Dom Conf column. The Dom Conf column also shows 'On' for channels 9, 10, 11, 12, and 13, and 'Off' for channels 7 and 8.

AI Symbols										DTX Symbols		
16										4		
	Channel Type	Enh/HSDPA Settings	Slot Fmt	Sym Rate /ksps	Chan Code	Power /dB	Data	DList Patt	T Offs	DPCCH Settings	State	Dom Conf
7	AICH			15	0	0.00				Config...	Off	
8	AP-AICH			15	0	0.00				Config...	Off	
9	PDSCH		4	240	0	0.00	PN 9				On	!
10	DL-DPCCH		0	7.5	0	0.00				Config...	On	!
11	DPCH	Config...	15	480	0	0.00	PN 9		0	Config...	On	!
12	HS-SCCH	Config...		30	5	0.00	PN 9				On	!
13	HS-PDS.QPSK	Config...		240	2	0.00	PN 9				On	!
14	DPCH		8	30	48	0.00	PN 9		9	Config...	On	!

- b) Select "3GPP FDD > Base Station > Code Domain"  
A code domain conflict is indicated by overlapping bars.

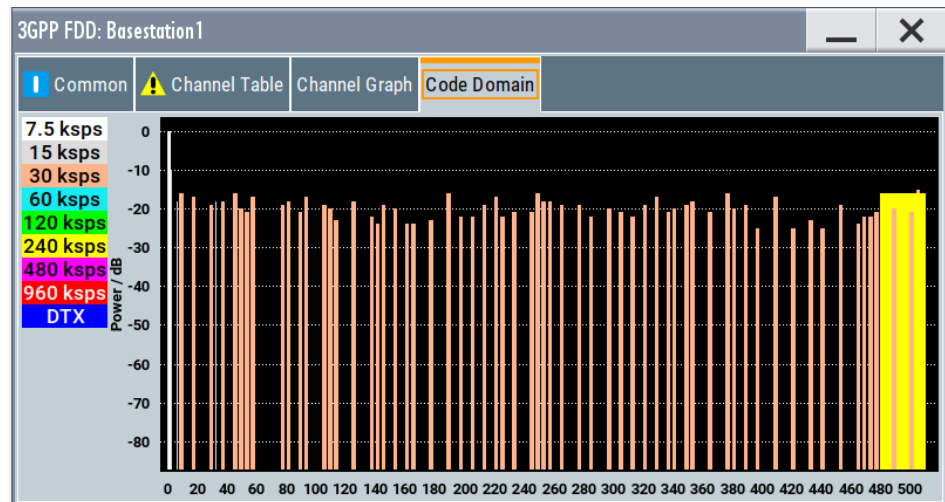

2. The instrument helps you to resolve code domain conflicts by automatically adapting the channelization code of the channels involved.  
To access the required function, in the "3GPP FDD > Base Station > Channel Table" select the conflict symbol and trigger "Resolve Domain Conflicts".

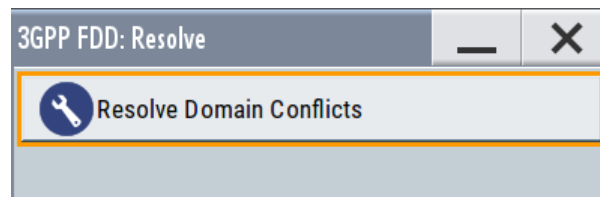

**Note:** The HSUPA control channels E-RGCH and E-HICH use the same channelization code as long as they use different signature sequence hopping index that identifies the user equipment. The F-DPCH channels also use the same channelization code as long as they use a different timing offset or slot format.

The code domain conflict is resolved by changing the channelization codes of the affected channels.

3GPP FDD: Basestation 1

Common Channel Table Channel Graph Code Domain

Multi Channel Assistant ... Reset All Channels Preset To HSDPA H-Set

Data 39

	Channel Type	Enh/HSDPA Settings	Slot Fmt	Sym Rate /ksp	Chan Code	Power /dB	Data	DList Patt	T Offs	DPCCH Settings	State	Dom Conf
7	AICH			15	0	0.00				Config...	Off	
8	AP-AICH			15	0	0.00				Config...	Off	
9	PDSCH		4	240	1	0.00	PN 9				On	
10	DL-DPCCH		0	7.5	8	0.00				Config...	On	
11	DPCH	Config...	15	480	1	0.00	PN 9		0	Config...	On	
12	HS-SCCH	Config...		30	3	0.00	PN 9				On	
13	HS-PDS.QPSK	Config...		240	4	0.00	PN 9				On	
14	DPCH		8	30	4	0.00	PN 9		9	Config...	On	

The graphs immediately display the change

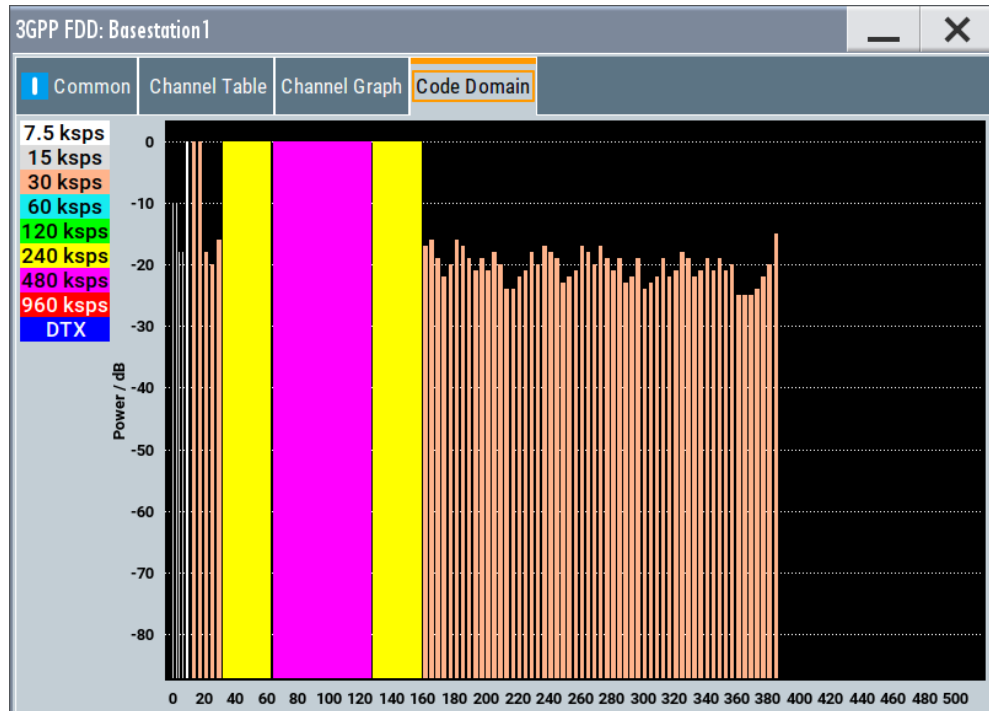

## 4.2 Using the DL-UL timing offset settings

To generate a continuous uplink signal composed of multiple separately generated uplink frames

1. Adjust the uplink settings as required and set "User Equipment > UE > DPCCH > DL-UL Timing Offset = 0 Chips".
2. Enable generation of the 3GPP FDD signal, i.e "3GPP FDD > State > On"
3. Use the [Generate Waveform](#) function to save the current signal as an ARB signal in a waveform file.
4. Reconfigure the uplink settings
5. Save the signal as an ARB file.
6. Use the "Baseband > ARB > Multi Segment" function to assemble a common signal from the several uplink signals.
7. If necessary, readjust the "Marker" settings.  
Use for example a sequence list to configure the order the waveforms are processed or to set how many times each of them is repeated.

## 4.3 Configuring UL-DTX transmission and visualizing the scheduling

To configure the instrument to generate an UL DPCCH DTX signal

1. Enable "Baseband > 3GPP FDD > Transmission Direction > Uplink".
2. Select "User Equipment > UE1 > UL-DTX".
3. Enable "Mode > UL-DTX". Configure the following settings:

**Table 4-1: UL-DTX Settings**

Parameter	Value
E-DCH TTI	2 ms
Offset	2 Subframes
Inactivity Threshold for Cycle 2	8 TTIs
Long Preamble Length	4 Slots
DTX Cycle 1 / DTX Cycle 2	4 Subframes and 8 Subframes respectively
DPCCH Burst Length 1 / DPCCH Burst Length 2	1 Subframe (3 Slots)
UL-DTX... / User Scheduling State	On

The figure below shows the generated UL DPCCH DTX bursts pattern.

- Use the [Scheduling list](#) to display the configured burst pattern.

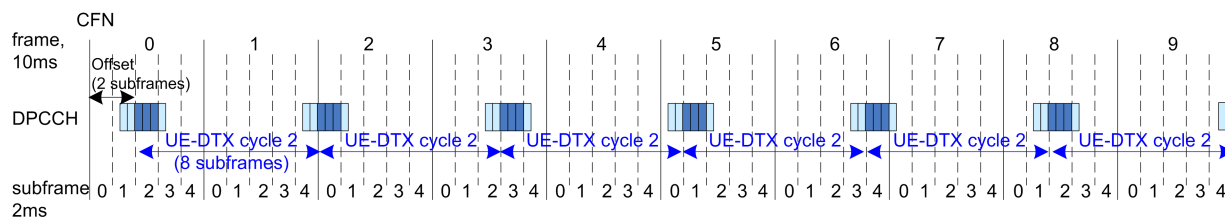

**Figure 4-1: Example for UL DPCCH DTX burst pattern as generated by the R&S SMBV100B (E-DCH TTI=2ms, beginning at CFN0, UE\_DTX\_DRX\_Offset=2, DTX Cycle 2=8 subframes)**

**Note:** In this implementation, the signal generation starts with UE-DTX cycle 2. The UL DPCCH DTX burst pattern is offset with two subframes. The burst is six slots long (2 slots Preamble + 3 slots DPCCH Burst Length 2 + 1 slot postamble). They are generated every eight subframes.

- Select "User Equipment > UE1 > E-DCH Scheduling Settings".
- Configure the settings as follows:

**Table 4-2: E-DCH scheduling settings**

Parameter	Value
Number of Table Rows	1
E-DCH Schedule Repeats After	24 TTIs
E-DCH TTI From	10
E-DCH TTI To	10

- Select "UE1 > E-DPDCH Settings > State > On" to enable the generation of E-DPDCH.

The "UE1 > Scheduling List" shows the updated UL DPCCH DTX bursts pattern (see also [Figure 4-2](#)).

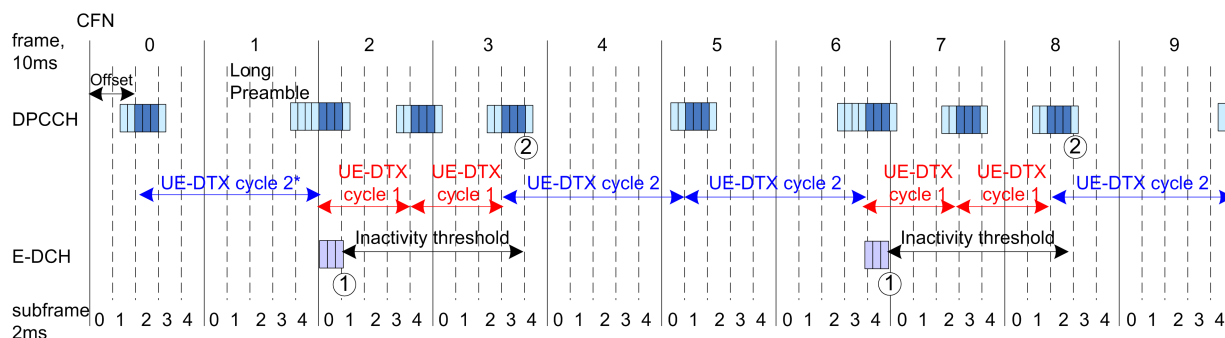

**Figure 4-2: Example for UL DPCCH DTX burst pattern in case of E-DCH transmission**

- 1 = Cycle 2 to Cycle 1 switch after E-DCH transmission
- 2 = Cycle 1 to Cycle 2 switch when the inactivity timer expires
- \*) = In the R&S SMBV100B, the signal generation starts with UE-DTX cycle 2.

8. Configure the "UE1 > HS-DPCCH Settings" as follows:

**Table 4-3: HS-DPCCH Settings**

Parameter	Value
Compatibility Mode (HS-DPCCH)	"Release 8 and Later RT"
Inter TTI Distance (Interval)	1 subframe
Number of Rows	1
HARQ-ACK Repeat After	40 intervals
HARQ-ACK From Interval/ HARQ-ACK To Interval	20 / 20
HS-DPCCH 1/2, HARQ-ACK 1/2/3/4	A
Number of Rows	1
PCI/CQI Repeat After	40 intervals
PCI-CQI From Interval/ PCI-CQI To Interval	2 / 2
HS-DPCCH 1/2, PCI/CQI 1/2/3/4 Type	CQI
CQI/CQI <sub>5</sub> /CQI <sub>1</sub> /CQI <sub>2</sub>	5

9. Select "UE1 > HS-DPCCH Settings > State > On" to enable the transmission of control signaling.

Figure 4-3 shows the generated UL DPCCH DTX bursts pattern.

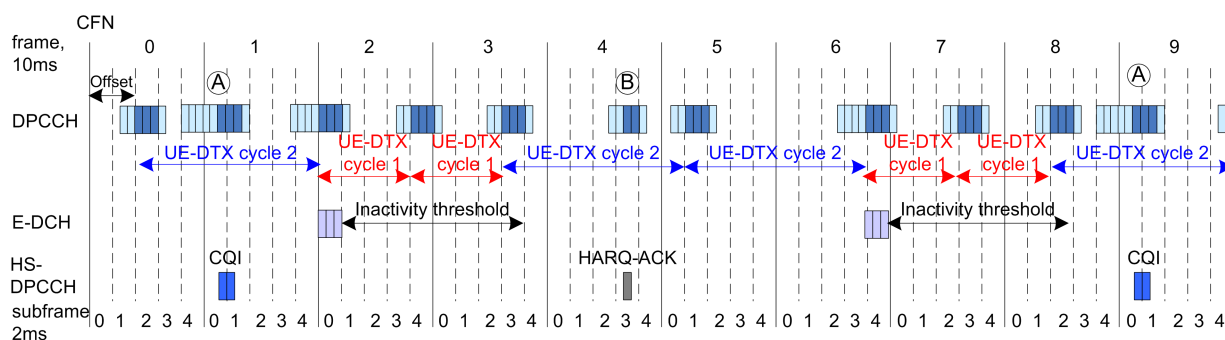

**Figure 4-3: Example for UL DPCCH DTX burst pattern in case of E-DCH and HS-DPCCH transmissions**

A = DPCCH burst caused by the transmission of a CQI report  
 B = DPCCH burst caused by the transmission of an HARQ-ACK message

Although there is an HS-DPCCH transmission, the UE does not switch from UE-DTX cycle 2 to UE-DTX cycle 1.

## 4.4 How to configure the HS-DPCCH settings for 4C-HSDPA tests

The following is an example on how to use the provided settings to configure the instrument to send ACK only messages. This transmission is required in the ACK mis-



detection test for 4C-HSDPA, according to 3GPP TS 25.141, section 8.11A.3 and 8.11A.4.

The example is based on the test configuration specified in 3GPP TS 25.141, annex A.9A.

**Table 4-4: Required test configurations (excerpt)**

Test Configuration	4/4/4	4/2/2	3/3/3	3/2/1	3/3/0
HS-DPCCH spreading factor	128	128	128	128	256
Secondary cell enabled	3	3	2	2	2
Secondary cell active	3	1	2	1	2
Number of MIMO carriers	4	2	3	1	0

#### To configure the 4C-HSDPA HS-DPCCH Reference Measurement Channel

The example lists only the related setting and is based on Test Configuration = 3/3/3, see [Table 4-4](#).

1. Enable "Baseband > 3GPP FDD > Link Direction > Uplink".
2. For "User Equipment > UE1", enable "HS-DPCCH > State > On".
3. Select "HS-DPCCH > MIMO Mode > On".
4. Select "HS-DPCCH > Secondary Cell Enabled > 2".
5. Select "HS-DPCCH > Secondary Cell Active > 2".
6. Use the default values "HS-DPCCH > HARQ-ACK Scheduling > Number of Rows > 1" and "HS-DPCCH > HARQ-ACK Scheduling > HARQ-ACK Repeat After > 1".
7. Select "HS-DPCCH > HARQ-ACK Scheduling > HS-DPCCH 1 HARQ-ACK 1 > AA/AA".

8. Select "HS-DPCCH > HARQ-ACK Scheduling > HS-DPCCH 1 HARQ-ACK 2 > AA/D".

3GPP FDD: User Equipment 1

General Code Domain DPCCH DPDCH **HS-DPCCH** E-DPCCH E-DPDCH E-DCH

Compatibility Mode: Release 8 and Later

Start Delay: 101 \*256 Chips

Inter TTI Distance (Interval): 5 Subframes

Channelization Code: Q / 32

Slot Format: 1 (30ksps)

MIMO Mode:

Secondary Cell Enabled: 2

Secondary Cell Active: 2

**HARQ - ACK**

Number of Rows: 1

HARQ-ACK Repeat After: 1 Intervals

	HARQ-ACK From Interval	HARQ-ACK To Interval	HS-DPCCH 1 HARQ-ACK 1	HS-DPCCH 1 HARQ-ACK 2	HS-DPCCH 2 HARQ-ACK 3	HS-DPCCH 2 HARQ-ACK 4	Pow Offs /dB
0	0	0	AA/AA	AA/D			0.0

## 5 Remote-control commands

The following commands are required to perform signal generation with the 3GPP FDD options in a remote environment. We assume that the R&S SMBV100B has already been set up for remote operation in a network as described in the R&S SMBV100B documentation. Knowledge about the remote control operation and the SCPI command syntax are assumed.



### Conventions used in SCPI command descriptions

For a description of the conventions used in the remote command descriptions, see section "Remote Control Commands" in the R&S SMBV100B user manual.

### Common suffixes

The following common suffixes are used in remote commands:

Suffix	Value range	Description
ENTity<ch>	1	Optional keyword, provided for compatibility with R&S®SMW200A  ENTity1:SOURce1 = SOURce1
SOURce<hw>	1	available baseband signals
OUTPut<ch>	1 to 3	available markers
BSTation<st>	1 to 4	Base station If the suffix is omitted, BS1 is selected.
CHANnel<ch>	0 to 138	channel If the suffix is omitted, Channel1 is selected.
MSTation<st>	1 to 4	user equipment. If the suffix is omitted, MS1 is selected.

The commands in the `SOURce:BB:W3GPP` subsystem are described in several sections, separated into general remote commands, commands for base station settings and commands for user equipment settings.

This subsystem contains commands for the primary and general settings of the 3GPP FDD standard. These settings concern activation of the standard, setting the transmission direction, filter, clock, trigger and clipping settings, defining the chip rate and the sequence length, as well as the preset and power adjust setting.

The commands for setting the base station and the user equipment, the enhanced channels of the base and user equipment, as well as the commands for selecting the test models and the test setups, are described in separate sections. The commands are divided up in this way to make the comprehensive `SOURce:BB:W3GPP` subsystem clearer.

The following commands specific to the 3GPP FDD options are described here:

• General commands.....	260
• Filter/clipping settings.....	266
• Trigger settings.....	271
• Marker settings.....	276
• Clock settings.....	277
• Test models and predefined settings.....	278
• Setting base stations.....	282
• Enhanced channels of base station 1.....	329
• User equipment settings.....	350
• Enhanced channels of the user equipment.....	431

## 5.1 General commands

<code>[:SOURce&lt;hw&gt;]:BB:W3GPp:PRESet</code> .....	260
<code>[:SOURce&lt;hw&gt;]:BB:W3GPp:SETTing:CATalog?</code> .....	260
<code>[:SOURce&lt;hw&gt;]:BB:W3GPp:SETTing:DELete</code> .....	261
<code>[:SOURce&lt;hw&gt;]:BB:W3GPp:SETTing:LOAD</code> .....	261
<code>[:SOURce&lt;hw&gt;]:BB:W3GPp:SETTing:STORE</code> .....	262
<code>[:SOURce&lt;hw&gt;]:BB:W3GPp:SLENgth</code> .....	262
<code>[:SOURce&lt;hw&gt;]:BB:W3GPp:STATe</code> .....	262
<code>[:SOURce&lt;hw&gt;]:BB:W3GPp:WAVeform:CREate</code> .....	263
<code>[:SOURce]:BB:W3GPp:GPP3:VERSion?</code> .....	263
<code>[:SOURce&lt;hw&gt;]:BB:W3GPp:BSTation:PRESet</code> .....	263
<code>[:SOURce&lt;hw&gt;]:BB:W3GPp:COPIY:COFFset</code> .....	263
<code>[:SOURce&lt;hw&gt;]:BB:W3GPp:COPIY:DESTination</code> .....	264
<code>[:SOURce&lt;hw&gt;]:BB:W3GPp:COPIY:EXECute</code> .....	264
<code>[:SOURce&lt;hw&gt;]:BB:W3GPp:COPIY:SOURce</code> .....	264
<code>[:SOURce&lt;hw&gt;]:BB:W3GPp:LINK</code> .....	265
<code>[:SOURce&lt;hw&gt;]:BB:W3GPp:POWer:ADJust</code> .....	265
<code>[:SOURce&lt;hw&gt;]:BB:W3GPp:POWer[:TOTal]?</code> .....	265

---

### `[:SOURce<hw>]:BB:W3GPp:PRESet`

Sets the parameters of the digital standard to their default values (\*RST values specified for the commands).

Not affected is the state set with the command `SOURce<hw>:BB:W3GPp:STATe`.

**Example:** `SOURce1:BB:W3GPp:PRESet`

**Usage:** Event

**Manual operation:** See "Set to default" on page 46

---

### `[:SOURce<hw>]:BB:W3GPp:SETTing:CATalog?`

This command reads out the files with 3GPP FDD settings in the default directory. The default directory is set using command `MMEM:CDIRectory`. Only files with the file extension \*.3g are listed.

**Return values:**

<Catalog> string

**Example:**

MMEM:CDIR '/var/user/temp/3gpp

Sets the default directory.

BB:W3GP:SETT:CAT?

Reads out all the files with 3GPP FDD settings in the default directory.

Response: UPLINK, DOWNLINK

The files UPLINK and DOWNLINK are available.

**Usage:**

Query only

**Manual operation:** See "Save/Recall" on page 46

**[[:SOURce<hw>]:BB:W3GPp:SETTING:DELeTe <Filename>**

This command deletes the selected file with 3GPP FDD settings. The directory is set using command `MMEM:CDIRectory`. A path can also be specified, in which case the files in the specified directory are read. The file extension can be omitted. Only files with the file extension `*.3g` are deleted.

**Setting parameters:**

<Filename> <file\_name>

**Example:**

BB:W3GP:SETT:DEL 'UPLINK'

Deletes file UPLINK.

**Usage:**

Setting only

**Manual operation:** See "Save/Recall" on page 46

**[[:SOURce<hw>]:BB:W3GPp:SETTING:LOAD <Filename>**

This command loads the selected file with 3GPP FDD settings. The directory is set using command `MMEM:CDIRectory`. A path can also be specified, in which case the files in the specified directory are read. The file extension can be omitted. Only files with the file extension `*.3g` are loaded.

**Setting parameters:**

<Filename> <file\_name>

**Example:**

BB:W3GP:SETT:LOAD 'UPLINK'

Loads file UPLINK.

**Usage:**

Setting only

**Manual operation:** See "Save/Recall" on page 46

**[:SOURce<hw>]:BB:W3GPp:SETTING:STORE <Filename>**

This command stores the current 3GPP FDD settings into the selected file. The directory is set using command `MMEM:CDIRectory`. A path can also be specified, in which case the files in the specified directory are read. Only enter the file name. 3GPP FDD settings are stored as files with the specific file extensions `*.3g`.

**Setting parameters:**

<Filename>            string

**Example:**            `BB:W3GP:SETT:STOR 'UPLINK'`  
Stores the current 3GPP FDD settings into file `UPLINK`.

**Usage:**                Setting only

**Manual operation:** See ["Save/Recall"](#) on page 46

**[:SOURce<hw>]:BB:W3GPp:SLENgth <SLength>**

Defines the sequence length of the arbitrary waveform component of the 3GPP signal in the number of frames. This component is calculated in advance and output in the arbitrary waveform generator. It is added to the realtime signal components (Enhanced Channels).

When working in Advanced Mode (`W3GP:BST1:CHAN:HSDP:HSET:AMOD ON`), it is recommended to adjust the current ARB sequence length to the suggested one.

**Parameters:**

<SLength>            integer  
Range:                1 to Max. No. of Frames = Arbitrary waveform  
                         memory size/(3.84 Mcps x 10 ms).  
\*RST:                 1

**Example:**            `BB:W3GP:SLEN 10`  
sets the sequence length to 10 frames.

**Manual operation:** See ["ARB Seq Length"](#) on page 94  
See ["ARB Sequence Length"](#) on page 227  
See ["ARB Sequence Length"](#) on page 238  
See ["Sequence Length ARB"](#) on page 250

**[:SOURce<hw>]:BB:W3GPp:STATe <State>**

Activates the standard and deactivates all the other digital standards and digital modulation modes in the same path.

**Parameters:**

<State>                1 | ON | 0 | OFF  
\*RST:                 0

**Example:**            `SOURce1:BB:W3GPp:STATe ON`

**Manual operation:** See ["State"](#) on page 45

---

**[ :SOURce<hw>]:BB:W3GPP:WAVEform:CREate <Filename>**

This command creates a waveform using the current settings of the 3GPP FDD menu. The file name is entered with the command. The file is stored with the predefined file extension \*.wv. The file name and the directory it is stored in are user-definable.

**Setting parameters:**

<Filename>            <file\_name>

**Example:**            MMEM:CDIR '/var/user/temp/waveform'  
sets the default directory to /var/user/temp/waveform.  
BB:W3GP:WAV:CRE 'gpp3\_bs'  
creates the waveform file gpp3\_bs.wv in the default directory.

**Usage:**              Setting only

**Manual operation:** See ["Generate Waveform"](#) on page 46

---

**[ :SOURce]:BB:W3GPP:GPP3:VERSion?**

The command queries the version of the 3GPP standard underlying the definitions.

**Return values:**

<Version>            string

**Example:**            BB:W3GP:GPP3:VERS?  
queries the 3GPP version.

**Usage:**              Query only

**Manual operation:** See ["3GPP Version"](#) on page 46

---

**[ :SOURce<hw>]:BB:W3GPP:BSTation:PRESet**

The command produces a standardized default for all the base stations. The settings correspond to the \*RST values specified for the commands.

All base station settings are preset.

**Example:**            BB:W3GP:BST:PRES  
resets all the base station settings to default values.

**Usage:**              Event

**Manual operation:** See ["Reset all Base Stations"](#) on page 57

---

**[ :SOURce<hw>]:BB:W3GPP:COPY:COFFset <COffset>**

Sets the offset for the channelization code in the destination base station.

**Parameters:**

<COffset>            integer  
Range:                0 to 511  
\*RST:                 0

**Example:** `BB:W3GP:COPY:COFF 10`  
the channelization code is shifted by 10 when the source base station is copied to the destination base station.

**Manual operation:** See ["Copy Basestation/Copy User Equipment..."](#) on page 58

#### **[:SOURce<hw>]:BB:W3GPp:COPY:DESTination <Destination>**

The command selects the station to which data is to be copied. Whether the data is copied to a base station or a user equipment depends on which transmission direction is selected (command `W3GPp:LINK UP | DOWN`).

**Parameters:**

<Destination> 1 | 2 | 3 | 4  
Range: 1 to 4  
\*RST: 2

**Example:** `BB:W3GP:LINK DOWN`  
selects the downlink transmit direction (base station to user equipment).  
`BB:W3GP:COPY:SOUR 1`  
selects base station 1 as the source.  
`BB:W3GP:COPY:DEST 4`  
selects base station 4 as the destination.  
`BB:W3GP:COPY:EXEC`  
starts copying the parameter set of base station 1 to base station 4.

**Manual operation:** See ["Copy Basestation/Copy User Equipment..."](#) on page 58

#### **[:SOURce<hw>]:BB:W3GPp:COPY:EXECute**

The command starts the copy process. The dataset of the source station is copied to the destination station. Whether the data is copied to a base station or a user equipment depends on which transmission direction is selected (command `W3GPp:LINK UP | DOWN`).

**Example:** `BB:W3GP:COPY:EXEC`  
starts copying the parameter set of the selected source station to the selected destination station.

**Usage:** Event

**Manual operation:** See ["Copy Basestation/Copy User Equipment..."](#) on page 58

#### **[:SOURce<hw>]:BB:W3GPp:COPY:SOURce <Source>**

The command selects the station that has data to be copied. Whether the station copied is a base or user equipment depends on which transmission direction is selected (command `W3GPp:LINK UP | DOWN`).



**Parameters:**

<Source>            1 | 2 | 3 | 4  
 Range:            1 to 4  
 \*RST:            1

**Example:**

BB:W3GP:LINK UP  
 selects the uplink transmit direction (user equipment to base station).  
 BB:W3GP:COPY:SOUR 1  
 selects user equipment 1 as the source.  
 BB:W3GP:COPY:DEST 4  
 selects user equipment 4 as the destination.  
 BB:W3GP:COPY:EXEC  
 starts copying the parameter set of user equipment 1 to user equipment 4.

**Manual operation:** See "[Copy Basestation/Copy User Equipment...](#)" on page 58

**[:SOURce<hw>]:BB:W3GPp:LINK <Link>**

The command defines the transmission direction. The signal either corresponds to that of a base station (FORWARD|DOWN) or that of a user equipment (REVERSE|UP).

**Parameters:**

<Link>            DOWN | UP | FORWARD | REVERSE  
 \*RST:            FORWARD|DOWN

**Example:**

BB:W3GP:LINK DOWN  
 the transmission direction selected is base station to user equipment. The signal corresponds to that of a base station.

**Manual operation:** See "[Link Direction](#)" on page 47

**[:SOURce<hw>]:BB:W3GPp:POWER:ADJUST**

The command sets the power of the active channels in such a way that the total power of the active channels is 0 dB. This does not change the power ratio among the individual channels.

**Example:**

BB:W3GP:POW:ADJ  
 The total power of the active channels is set to 0 dB, the power ratio among the individual channels is unchanged.

**Usage:**

Event

**Manual operation:** See "[Adjust Total Power To 0 dB](#)" on page 59

**[:SOURce<hw>]:BB:W3GPp:POWER[:TOTAL]?**

The command queries the total power of the active channels. After "Power Adjust", this power corresponds to 0 dB.

**Return values:**

<Total> float

**Example:**

BB:W3GP:POW?

queries the total power of the active channels.

Response: -22.5

the total power is -25 dB.

**Usage:**

Query only

**Manual operation:** See "[Total Power](#)" on page 59

## 5.2 Filter/clipping settings

<a href="#">[:SOURce&lt;hw&gt;]:BB:W3GPp:CLIPping:LEVel</a> .....	266
<a href="#">[:SOURce&lt;hw&gt;]:BB:W3GPp:CLIPping:MODE</a> .....	267
<a href="#">[:SOURce&lt;hw&gt;]:BB:W3GPp:CLIPping:STATe</a> .....	267
<a href="#">[:SOURce&lt;hw&gt;]:BB:W3GPp:CRATe?</a> .....	267
<a href="#">[:SOURce&lt;hw&gt;]:BB:W3GPp:CRATe:VARiation</a> .....	268
<a href="#">[:SOURce&lt;hw&gt;]:BB:W3GPp:FILTer:PARAmeter:APCO25</a> .....	268
<a href="#">[:SOURce&lt;hw&gt;]:BB:W3GPp:FILTer:PARAmeter:COSSine</a> .....	268
<a href="#">[:SOURce&lt;hw&gt;]:BB:W3GPp:FILTer:PARAmeter:GAUSSs</a> .....	268
<a href="#">[:SOURce&lt;hw&gt;]:BB:W3GPp:FILTer:PARAmeter:LPASs</a> .....	269
<a href="#">[:SOURce&lt;hw&gt;]:BB:W3GPp:FILTer:PARAmeter:LPASSEVM</a> .....	269
<a href="#">[:SOURce&lt;hw&gt;]:BB:W3GPp:FILTer:PARAmeter:RCOSSine</a> .....	269
<a href="#">[:SOURce&lt;hw&gt;]:BB:W3GPp:FILTer:PARAmeter:SPHase</a> .....	270
<a href="#">[:SOURce&lt;hw&gt;]:BB:W3GPp:FILTer:TYPE</a> .....	270

---

**`[:SOURce<hw>]:BB:W3GPp:CLIPping:LEVel <Level>`**

The command sets the limit for level clipping (Clipping). This value indicates at what point the signal is clipped. It is specified as a percentage, relative to the highest level. 100% indicates that clipping does not take place.

Level clipping is activated with the command `SOUR:BB:W3GP:CLIP:STAT ON`

**Parameters:**

<Level> integer  
Range: 1 to 100  
\*RST: 100

**Example:**

BB:W3GP:CLIP:LEV 80PCT

sets the limit for level clipping to 80% of the maximum level.

BB:W3GP:CLIP:STAT ON

activates level clipping.

**Manual operation:** See "[Clipping Level](#)" on page 249

---

**[[:SOURce<hw>]:BB:W3GPp:CLIPping:MODE <Mode>**

The command sets the method for level clipping (Clipping).

**Parameters:**

<Mode>                    VECTor | SCALar

**VECTor**

The reference level is the amplitude | i+jq |

**SCALar**

The reference level is the absolute maximum of the I and Q values.

\*RST:            VECTor

**Example:**

BB:W3GP:CLIP:MODE SCAL

selects the absolute maximum of all the I and Q values as the reference level.

BB:W3GP:CLIP:LEV 80PCT

sets the limit for level clipping to 80% of this maximum level.

BB:W3GP:CLIP:STAT ON

activates level clipping.

**Manual operation:** See "[Clipping Mode](#)" on page 249

---

**[[:SOURce<hw>]:BB:W3GPp:CLIPping:STATe <State>**

Activates level clipping.

**Parameters:**

<State>                    1 | ON | 0 | OFF

\*RST:            0

**Example:**

BB:W3GP:CLIP:STAT ON

activates level clipping.

**Manual operation:** See "[Clipping State](#)" on page 247

---

**[[:SOURce<hw>]:BB:W3GPp:CRATe?**

The command queries the set system chip rate. The output chip rate can be set with the command SOUR:BB:W3GP:CRAT:VAR.

**Return values:**

<CRate>                    R3M8

\*RST:            R3M8

**Example:**

BB:W3GP:CRAT?

queries the system chip rate.

Response: R3M8

the system chip rate is 3.8 Mcps.

**Usage:**

Query only

**Manual operation:** See "[Chip Rate](#)" on page 47

---

**[[:SOURce<hw>]:BB:W3GPp:CRATe:VARiation <Variation>**

Sets the output chip rate.

The chip rate entry changes the output clock and the modulation bandwidth, as well as the synchronization signals that are output. It does not affect the calculated chip sequence.

**Parameters:**

<Variation> float  
 Range: 400 to 5E6  
 Increment: 0.001  
 \*RST: 3.84 MCps

**Example:** BB:W3GP:CRAT:VAR 4086001  
 sets the chip rate to 4.08 Mcps.

**Manual operation:** See "[Chip Rate Variation](#)" on page 247

---

**[[:SOURce<hw>]:BB:W3GPp:FILTer:PARAmeter:APCO25 <Apco25>**

The command sets the roll-off factor for filter type APCO25.

**Parameters:**

<Apco25> float  
 Range: 0.05 to 0.99  
 Increment: 0.01  
 \*RST: 0.2

**Example:** BB:W3GP:FILT:PAR:APCO25 0.2  
 sets the roll-off factor to 0.2 for filter type APCO25.

**Manual operation:** See "[Roll Off Factor or BxT](#)" on page 246

---

**[[:SOURce<hw>]:BB:W3GPp:FILTer:PARAmeter:COSSine <Cosine>**

The command sets the roll-off factor for the Cosine filter type.

**Parameters:**

<Cosine> float  
 Range: 0 to 1  
 Increment: 0.01  
 \*RST: 0.35

**Example:** BB:W3GP:FILT:PAR:COS 0.35  
 sets the roll-off factor to 0.35 for filter type Cosine.

**Manual operation:** See "[Roll Off Factor or BxT](#)" on page 246

---

**[[:SOURce<hw>]:BB:W3GPp:FILTer:PARAmeter:GAUSSs <Gauss>**

The command sets the roll-off factor for the Gauss filter type.

**Parameters:**

<Gauss> float  
 Range: 0.15 to 2.5  
 Increment: 0.01  
 \*RST: 0.5

**Example:**

BB:W3GP:FILT:PAR:GAUS 0.5  
 sets B x T to 0.5 for the Gauss filter type.

**Manual operation:** See "[Roll Off Factor or BxT](#)" on page 246

**[:SOURCE<hw>]:BB:W3GPp:FILT:PAR:LPASs <LPass>**

Sets the cut off frequency factor for the Lowpass (ACP opt.) filter type. The minimum/maximum values depend on the current symbol rate:

**Parameters:**

<LPass> float  
 Range: 0.05 to 2  
 Increment: 0.01  
 \*RST: 0.5

**Example:**

BB:W3GP:FILT:PAR:LPAS 0.5  
 the cut of frequency factor is set to 0.5.

**Manual operation:** See "[Cut Off Frequency Factor](#)" on page 247

**[:SOURCE<hw>]:BB:W3GPp:FILT:PAR:LPASSEVM <LPassEvm>**

Sets the cut off frequency factor for the Lowpass (EVM opt.) filter type.

**Parameters:**

<LPassEvm> float  
 Range: 0.05 to 2  
 Increment: 0.01  
 \*RST: 0.5

**Example:**

BB:W3GP:FILT:PAR:LPASSEVM 0.5  
 the cut of frequency factor is set to 0.5.

**Manual operation:** See "[Cut Off Frequency Factor](#)" on page 247

**[:SOURCE<hw>]:BB:W3GPp:FILT:PAR:RCOSine <RCosine>**

The command sets the roll-off factor for the Root Cosine filter type.

**Parameters:**

<RCosine> float  
 Range: 0 to 1.0  
 Increment: 0.01  
 \*RST: 0.22

**Example:** `BB:W3GP:FILT:PAR:RCOS 0.22`  
sets the roll-off factor to 0.22 for filter type Root Cosine.

**Manual operation:** See "[Roll Off Factor or BxT](#)" on page 246

**[[:SOURce<hw>]:BB:W3GPp:FILTer:PARAMeter:SPHase <SPHase>**

The command sets B x T for the Split Phase filter type.

**Parameters:**

<SPHase> float  
Range: 0.15 to 2.5  
Increment: 0.01  
\*RST: 2

**Example:** `BB:W3GP:FILT:PAR:SPH 0.5`  
sets B x T to 0.5 for the Split Phase filter type.

**Manual operation:** See "[Roll Off Factor or BxT](#)" on page 246

**[[:SOURce<hw>]:BB:W3GPp:FILTer:TYPE <Type>**

Selects the filter type.

**Parameters:**

<Type> RCOSine | COSine | GAUSs | LGAuss | CONE | COF705 |  
COEQUALizer | COFEQUALizer | C2K3x | APCO25 | SPHase |  
RECTangle | LPASs | DIRac | ENPShape | EWPSHape |  
LPASSEVM | PGAuss  
COSine = "Cosine" = Raised Cosine  
RCOSine = "Root Cosine" = Root Raised Cosine (RRC)  
\*RST: RCOSine

**Example:** `SOURce1:BB:W3GPp:FILTer:TYPE RCOS`  
Select RRC filter.

**Manual operation:** See "[Filter](#)" on page 246

## 5.3 Trigger settings

### Example: Trigger configuration

```

SOURce1:BB:W3GPp:TRIGger:SOURce INTernal
SOURce1:BB:W3GPp:TRIGger:SEQuence ARETrigger
SOURce1:BB:W3GPp:STAT ON
SOURce1:BB:W3GPp:TRIGger:EXECute
SOURce1:BB:W3GPp:TRIGger:ARM:EXECute
SOURce1:BB:W3GPp:TRIGger:RMODE?
// stopped
SOURce1:BB:W3GPp:TRIGger:EXECute
SOURce1:BB:W3GPp:TRIGger:RMODE?
// run

// SOURce1:BB:W3GPp:TRIGger:SEQuence SING
// SOURce1:BB:W3GPp:TRIGger:SLUNit SEQuence
// SOURce1:BB:W3GPp:TRIGger:SLENGth 2

// SOURce1:BB:W3GPp:TRIGger:SEQuence ARET
// SOURce1:BB:W3GPp:TRIGger:SOURce EGT1
// SOURce1:BB:W3GPp:TRIGger:EXTernal:SYNChronize:OUTPut 1
// SOURce1:BB:W3GPp:TRIGger:EXTernal:INHibit 100
// SOURce1:BB:W3GPp:TRIGger:EXTernal:DELAy 10

```

<a href="#">[:SOURce&lt;hw&gt;]:BB:W3GPp[:TRIGger]:SEQuence.....</a>	271
<a href="#">[:SOURce&lt;hw&gt;]:BB:W3GPp:TRIGger:SOURce.....</a>	272
<a href="#">[:SOURce&lt;hw&gt;]:BB:W3GPp:TRIGger:ARM:EXECute.....</a>	272
<a href="#">[:SOURce&lt;hw&gt;]:BB:W3GPp:TRIGger:EXECute.....</a>	272
<a href="#">[:SOURce&lt;hw&gt;]:BB:W3GPp:TRIGger:EXTernal:SYNChronize:OUTPut.....</a>	273
<a href="#">[:SOURce&lt;hw&gt;]:BB:W3GPp:TRIGger:RMODE?.....</a>	273
<a href="#">[:SOURce&lt;hw&gt;]:BB:W3GPp:TRIGger:TIME:DATE.....</a>	273
<a href="#">[:SOURce&lt;hw&gt;]:BB:W3GPp:TRIGger:TIME:TIME.....</a>	274
<a href="#">[:SOURce&lt;hw&gt;]:BB:W3GPp:TRIGger:TIME[:STATe].....</a>	274
<a href="#">[:SOURce&lt;hw&gt;]:BB:W3GPp:TRIGger:SLENGth.....</a>	274
<a href="#">[:SOURce&lt;hw&gt;]:BB:W3GPp:TRIGger:SLUNit.....</a>	275
<a href="#">[:SOURce&lt;hw&gt;]:BB:W3GPp:TRIGger[:EXTernal]:DELAy.....</a>	275
<a href="#">[:SOURce&lt;hw&gt;]:BB:W3GPp:TRIGger[:EXTernal]:INHibit.....</a>	275

---

### **[:SOURce<hw>]:BB:W3GPp[:TRIGger]:SEQuence <Sequence>**

Selects the trigger mode:

- AUTO = auto
- RETRigger = retrigger
- AAUTO = armed auto
- ARETrigger = armed retrigger
- SINGle = single

**Parameters:**

<Sequence> AUTO | RETRigger | AAUTo | ARETrigger | SINGLE  
 \*RST: AUTO

**Example:** See [Example"Trigger configuration"](#) on page 271

**Manual operation:** See ["Mode"](#) on page 49

**[[:SOURce<hw>]:BB:W3GPp:TRIGger:SOURce <Source>**

Selects the trigger signal source and determines the way the triggering is executed. Provided are:

- Internal triggering by a command (INTernal)
- External trigger signal via one of the User x connectors  
EGT1: External global trigger
- In primary-secondary instrument mode, the external baseband synchronization signal (BBSY)
- EXTernal: Setting only  
Provided only for backward compatibility with other Rohde & Schwarz signal generators.  
The R&S SMBV100B accepts this value and maps it automatically as follows:  
EXTernal = EGT1

**Parameters:**

<Source> INTernal|EGT1|EXTernal|BBSY  
 \*RST: INTernal

**Example:** See [Example"Trigger configuration"](#) on page 271.

**Manual operation:** See ["Source"](#) on page 50

**[[:SOURce<hw>]:BB:W3GPp:TRIGger:ARM:EXECute**

Stops signal generation; a subsequent trigger event restarts signal generation.

**Example:** See [Example"Trigger configuration"](#) on page 271

**Usage:** Event

**Manual operation:** See ["Arm"](#) on page 50

**[[:SOURce<hw>]:BB:W3GPp:TRIGger:EXECute**

Executes a trigger.

**Example:** See [Example"Trigger configuration"](#) on page 271

**Usage:** Event

**Manual operation:** See ["Execute Trigger"](#) on page 50



---

**[ :SOURce<hw>]:BB:W3GPp:TRIGger:EXTeRnal:SYNChronize:OUTPut <Output>**

Enables signal output synchronous to the trigger event.

**Parameters:**

<Output>            1 | ON | 0 | OFF  
 \*RST:            1

**Example:**            See [Example "Trigger configuration"](#) on page 271

**Manual operation:** See ["Sync. Output to External Trigger/Sync. Output to Trigger"](#) on page 51

---

**[ :SOURce<hw>]:BB:W3GPp:TRIGger:RMODe?**

Queries the signal generation status.

**Return values:**

<RMode>            STOP | RUN  
 \*RST:            STOP

**Example:**            See [Example "Trigger configuration"](#) on page 271

**Usage:**            Query only

**Manual operation:** See ["Running/Stopped"](#) on page 49

---

**[ :SOURce<hw>]:BB:W3GPp:TRIGger:TIME:DATE <Year>, <Month>, <Day>**

Sets the date for a time-based trigger signal. For trigger modes single or armed auto, you can activate triggering at this date via the following command:

SOURce<hw>:BB:<DigStd>:TRIGger:TIME:STATE

<DigStd> is the mnemonic for the digital standard, for example, ARB. Time-based triggering behaves analogously for all digital standards that support this feature.

**Parameters:**

<Year>            integer  
                     Range:      1980 to 9999

<Month>           integer  
                     Range:      1 to 12

<Day>            integer  
                     Range:      1 to 31

**Example:**            See example "Configure a time-based trigger signal" in the sub-chapter "Trigger Commands" of the chapter "SOURce:BB:ARB subsystem" in the R&S SMBV100B user manual.

**Manual operation:** See ["Trigger Time"](#) on page 50

---

```
[ :SOURce<hw>]:BB:W3GPP:TRIGger:TIME:TIME <Hour>, <Minute>, <Second>
```

Sets the time for a time-based trigger signal. For trigger modes single or armed auto, you can activate triggering at this time via the following command:

```
SOURce<hw>:BB:<DigStd>:TRIGger:TIME:STATE
```

<DigStd> is the mnemonic for the digital standard, for example, ARB. Time-based triggering behaves analogously for all digital standards that support this feature.

**Parameters:**

<Hour>	integer	
	Range:	0 to 23
<Minute>	integer	
	Range:	0 to 59
<Second>	integer	
	Range:	0 to 59

**Example:** See example "Configure a time-based trigger signal" in the sub-chapter "Trigger Commands" of the chapter "SOURce:BB:ARB subsystem" in the R&S SMBV100B user manual.

**Manual operation:** See ["Trigger Time"](#) on page 50

---

```
[ :SOURce<hw>]:BB:W3GPP:TRIGger:TIME[:STATE] <State>
```

Activates time-based triggering with a fixed time reference. If activated, the R&S SMBV100B triggers signal generation when its operating system time matches a specified time.

Specify the trigger date and trigger time with the following commands:

```
SOURce<hw>:BB:<DigStd>:TRIGger:TIME:DATE
```

```
SOURce<hw>:BB:<DigStd>:TRIGger:TIME:TIME
```

<DigStd> is the mnemonic for the digital standard, for example, ARB. Time-based triggering behaves analogously for all digital standards that support this feature.

**Parameters:**

<State>	1   ON   0   OFF
*RST:	0

**Example:** See example "Configure a time-based trigger signal" in the sub-chapter "Trigger Commands" of the chapter "SOURce:BB:ARB subsystem" in the R&S SMBV100B user manual.

**Manual operation:** See ["Time Based Trigger"](#) on page 50

---

```
[ :SOURce<hw>]:BB:W3GPP:TRIGger:SLENgth <SLength>
```

Defines the length of the signal sequence that is output in the SINGLE trigger mode.

**Parameters:**

<SLength> integer  
 Range: 1 to 4293120000  
 \*RST: 1

**Example:** See [Example"Trigger configuration"](#) on page 271

**Manual operation:** See ["Signal Duration"](#) on page 49

**[[:SOURce<hw>]:BB:W3GPP:TRIGger:SLUNit <SLunit>**

Defines the unit for the entry of the signal sequence length.

**Parameters:**

<SLunit> CHIP | FRAMe | SLOt | SEQuence  
 \*RST: SEQuence

**Example:** See [Example"Trigger configuration"](#) on page 271

**Manual operation:** See ["Signal Duration Unit"](#) on page 49

**[[:SOURce<hw>]:BB:W3GPP:TRIGger[:EXTernal]:DELay <Delay>**

Sets the trigger delay.

**Parameters:**

<Delay> float  
 Range: 0 to 2147483647  
 Increment: 0.01  
 \*RST: 0  
 Default unit: samples

**Example:** See [Example"Trigger configuration"](#) on page 271.

**Manual operation:** See ["Trigger Delay"](#) on page 52

**[[:SOURce<hw>]:BB:W3GPP:TRIGger[:EXTernal]:INHibit <Inhibit>**

Specifies the duration by which a restart is inhibited.

**Parameters:**

<Inhibit> integer  
 Range: 0 to 21.47\*chipRate  
 \*RST: 0

**Example:** See [Example"Trigger configuration"](#) on page 271.

**Manual operation:** See ["External Inhibit/Trigger Inhibit"](#) on page 52

## 5.4 Marker settings

### Example: Marker configuration

```
SOURce1:BB:W3GPp:TRIGger:OUTPut1:MODE USER
SOURce1:BB:W3GPp:TRIGger:OUTPut1:PERiod 38400
```

```
SOURce1:BB:W3GPp:TRIGger:OUTPut1:MODE RAT
SOURce1:BB:W3GPp:TRIGger:OUTPut1:ONTime 1
SOURce1:BB:W3GPp:TRIGger:OUTPut1:OFFTime 1
// defines the on/off ratio
```

```
// Marker delay configuration
SOURce1:BB:W3GPp:TRIGger:OUTPut2:DELay 1600
```

<code>[:SOURce&lt;hw&gt;]:BB:W3GPp:TRIGger:OUTPut&lt;ch&gt;:MODE</code> .....	276
<code>[:SOURce&lt;hw&gt;]:BB:W3GPp:TRIGger:OUTPut&lt;ch&gt;:ONTime</code> .....	276
<code>[:SOURce&lt;hw&gt;]:BB:W3GPp:TRIGger:OUTPut&lt;ch&gt;:OFFTime</code> .....	276
<code>[:SOURce&lt;hw&gt;]:BB:W3GPp:TRIGger:OUTPut&lt;ch&gt;:PERiod</code> .....	277
<code>[:SOURce&lt;hw&gt;]:BB:W3GPp:TRIGger:OUTPut&lt;ch&gt;:DELay</code> .....	277

---

**`[:SOURce<hw>]:BB:W3GPp:TRIGger:OUTPut<ch>:MODE <Mode>`**

Defines the signal for the selected marker output.

#### Parameters:

<Mode>                   SLOT | RFRame | CSPeriod | SFNR | RATio | USER

SLOT = Slot

RFRame = Radio Frame

CSPeriod = Chip Sequence Period (ARB)

SFNR = System Frame Number (SFN) Restart

RATio = ON/OFF Ratio

USER = User

\*RST:           RFRame

**Example:**           SOURce1:BB:W3GPp:TRIGger:OUTPut2:MODE SLOT  
selects the slot marker for the corresponding marker signal.

**Manual operation:** See "[Marker Mode](#)" on page 53

---

**`[:SOURce<hw>]:BB:W3GPp:TRIGger:OUTPut<ch>:ONTime <OnTime>`**  
**`[:SOURce<hw>]:BB:W3GPp:TRIGger:OUTPut<ch>:OFFTime <OffTime>`**

Sets the number of chips during which the marker output is on or off.

#### Parameters:

<OffTime>               integer

Range:           1 to 16777215

\*RST:           1

Default unit: chip

**Example:** See [Example"Marker configuration"](#) on page 276

**Manual operation:** See ["Marker Mode"](#) on page 53

**[:SOURce<hw>]:BB:W3GPp:TRIGger:OUTPut<ch>:PERiod <Period>**

Sets the repetition rate for the signal at the marker outputs.

**Parameters:**

<Period> integer  
 Range: 1 to 2<sup>32</sup>-1 chips  
 \*RST: 38400

**Example:** See [Example"Marker configuration"](#) on page 276.

**Manual operation:** See ["Marker Mode"](#) on page 53

**[:SOURce<hw>]:BB:W3GPp:TRIGger:OUTPut<ch>:DELay <Delay>**

Defines the delay between the signal on the marker outputs and the start of the signals.

**Parameters:**

<Delay> float  
 Range: 0 to 16777215  
 Increment: 1  
 \*RST: 0

**Example:** See [Example"Marker configuration"](#) on page 276

**Manual operation:** See ["Marker x Delay"](#) on page 54

## 5.5 Clock settings

[\[:SOURce<hw>\]:BB:W3GPp:CLOCK:SOURce.....](#) 277

**[:SOURce<hw>]:BB:W3GPp:CLOCK:SOURce <Source>**

Selects the clock source:

- `INTernal`: Internal clock reference

**Parameters:**

<Source> INTernal  
 \*RST: INTernal

**Example:** `SOURce1:BB:W3GPp:CLOCK:SOURce INTernal`  
 selects an internal clock reference.

## 5.6 Test models and predefined settings

The provided commands give you the opportunity to generate standardized or predefined test settings:

- Test Models:
  - Selection of test models for the downlink in accordance with 3GPP standard 25.141.
  - Selection of non-standardized test models for the uplink.
- Predefined Settings:
 

Definition of Predefined Settings for base station 1 which enable the creation of highly complex scenarios for the downlink by presetting the channel table of base station 1. The settings take effect only after execution of command

```
BB:W3GPp:PPARameter:EXECute.
```

<code>[:SOURce&lt;hw&gt;]:BB:W3GPp:PPARameter:CRESt</code> .....	278
<code>[:SOURce&lt;hw&gt;]:BB:W3GPp:PPARameter:DPCH:COUNT</code> .....	279
<code>[:SOURce&lt;hw&gt;]:BB:W3GPp:PPARameter:DPCH:SRATe</code> .....	279
<code>[:SOURce&lt;hw&gt;]:BB:W3GPp:PPARameter:EXECute</code> .....	279
<code>[:SOURce&lt;hw&gt;]:BB:W3GPp:PPARameter:SCCPch:SRATe</code> .....	280
<code>[:SOURce&lt;hw&gt;]:BB:W3GPp:PPARameter:SCCPch:STATe</code> .....	280
<code>[:SOURce&lt;hw&gt;]:BB:W3GPp:PPARameter:SCHannels</code> .....	280
<code>[:SOURce&lt;hw&gt;]:BB:W3GPp:SETTing:TMODeI:BSTation</code> .....	281
<code>[:SOURce&lt;hw&gt;]:BB:W3GPp:SETTing:TMODeI:BSTation:CATalog?</code> .....	281
<code>[:SOURce&lt;hw&gt;]:BB:W3GPp:SETTing:TMODeI:MSStation</code> .....	281
<code>[:SOURce&lt;hw&gt;]:BB:W3GPp:SETTing:TMODeI:MSStation:CATalog?</code> .....	282

---

### `[:SOURce<hw>]:BB:W3GPp:PPARameter:CRESt <Crest>`

This command selects the desired range for the crest factor of the test scenario. The crest factor of the signal is kept in the desired range by automatically setting appropriate channelization codes and timing offsets.

The setting takes effect only after execution of command

```
BB:W3GPp:PPARameter:EXECute.
```

The settings of commands

- `BB:W3GP:BST<n>:CHAN<n>:CCODE` and
- `BB:W3GP:BST<n>:CHAN<n>:TOFFset`

Are adjusted according to the selection.

#### Parameters:

`<Crest>`                    MINimum | AVERage | WORSt

#### **MINimum**

The crest factor is minimized. The channelization codes are distributed uniformly over the code domain. The timing offsets are increased by 3 per channel.

**AVERAge**

An average crest factor is set. The channelization codes are distributed uniformly over the code domain. The timing offsets are all set to 0.

**WORSt**

The crest factor is set to an unfavorable value (i.e. maximum). The channelization codes are assigned in ascending order. The timing offsets are all set to 0.

\*RST: MINimum

**Example:**

BB:W3GP:PPAR:CRES WORS

Sets the crest factor to an unfavorable value.

**Manual operation:** See "[Crest Factor](#)" on page 66

**[:SOURce<hw>]:BB:W3GPp:PPARAmeter:DPCH:COUNT <Count>**

Sets the number of activated DPCHs. The maximum number is the ratio of the chip rate and the symbol rate (maximum 512 at the lowest symbol rate of 7.5 ksps).

**Parameters:**

<Count> integer  
 Range: 0 to 512 (Max depends on other settings)  
 \*RST: 10

**Example:**

BB:W3GP:PPAR:DPCH:COUN 21

the predefined signal contains 21 DPCHs.

BB:W3GPp:PPARAmeter:EXECute

**Manual operation:** See "[Number of DPCH](#)" on page 66

**[:SOURce<hw>]:BB:W3GPp:PPARAmeter:DPCH:SRATe <SRate>**

This command sets the symbol rate of DPCHs.

The setting takes effect only after execution of command

BB:W3GPp:PPARAmeter:EXECute.

**Parameters:**

<SRate> D7K5 | D15K | D30K | D60K | D120k | D240k | D480k | D960k  
 \*RST: D30K

**Example:**

BB:W3GP:PPAR:DPCH:SRAT D240K

sets the symbol rate of the DPCHs to 240ksps.

**Manual operation:** See "[Symbol Rate DPCH](#)" on page 66

**[:SOURce<hw>]:BB:W3GPp:PPARAmeter:EXECute**

This command presets the channel table of base station 1 with the parameters defined by the PPARAmeter commands.

**Example:** `BB:W3GP:PPAR:EXEC`  
configures the signal sequence as defined by the `:PPARameter` commands.

**Usage:** Event

**Manual operation:** See "[Accept](#)" on page 66

**[:SOURce<hw>]:BB:W3GPp:PPARameter:SCCPch:SRATe <SRate>**

The command sets the symbol rate of S-CCPCH.

The setting takes effect only after execution of command

`BB:W3GPp:PPARameter:EXECute.`

**Parameters:**

<SRate> D15K | D30K | D60K | D120k | D240k | D480k | D960k  
\*RST: D30K

**Example:** `BB:W3GP:PPAR:SCCP:SRAT D240K`  
'sets the SCCPCH to 240 kbps.

**Manual operation:** See "[Symbol Rate S-CCPCH](#)" on page 66

**[:SOURce<hw>]:BB:W3GPp:PPARameter:SCCPch:STATe <State>**

Activates/deactivates the S-CCPCH.

**Parameters:**

<State> 1 | ON | 0 | OFF  
\*RST: 0

**Example:** `BB:W3GP:PPAR:SCCP:STAT ON`  
S-CCPCH is activated.  
`BB:W3GPp:PPARameter:EXECute`

**Manual operation:** See "[Use S-CCPCH](#)" on page 65

**[:SOURce<hw>]:BB:W3GPp:PPARameter:SCHannels <SChannels>**

The command activates/deactivates the PCPICH, PSCH, SSCH and PCCPCH. These "special channels" are required by a user equipment for synchronization.

The setting takes effect only after execution of command

`BB:W3GPp:PPARameter:EXECute.`

**Parameters:**

<SChannels> 1 | ON | 0 | OFF  
\*RST: 0

**Manual operation:** See "[Use Channels](#)" on page 65



---

**[ :SOURce<hw>]:BB:W3GPP:SETTing:TMODeL:BSTation <BStation>**

Selects a standard test model for the downlink.

**Parameters:**

<BStation>                    string

**Example:**

SOURce1:BB:W3GPP:SETTing:TMODeL:BSTation:  
CATalog?

queries the list of available test models for the downlink transmission direction.

Response: Test\_Model\_1\_16channels, ...

SOURce1:BB:W3GPP:SETTing:TMODeL:BSTation:  
"Test\_Model\_1\_64channels"

selects the test model Measurement: Spectrum emission mask ACLR; 64 Channels.

**Manual operation:** See "[Test Models Downlink](#)" on page 62

---

**[ :SOURce<hw>]:BB:W3GPP:SETTing:TMODeL:BSTation:CATalog?**

Queries the list of test models defined by the standard for the downlink.

**Return values:**

<Catalog>                    string

**Example:**

see [\[:SOURce<hw>\]:BB:W3GPP:SETTing:TMODeL:BSTation](#) on page 281

**Usage:**                    Query only

**Manual operation:** See "[Test Models Downlink](#)" on page 62

---

**[ :SOURce<hw>]:BB:W3GPP:SETTing:TMODeL:MSTation <MStation>**

The command selects a test model that is not defined by the standard for the uplink.

**Parameters:**

<MStation>                    string

**DPCCH\_DPDCH\_60ksps**

Preset, Uplink, UE1 on, DPDCH + DPCCH, Overall symbol rate 60 ksps.

**DPCCH\_DPDCH960ksps**

Preset, Uplink, UE1 on, DPDCH + DPCCH, Overall symbol rate 960 ksps

**TS34121\_R6\_Table\_C\_10\_1\_4\_Subtest4**

Uplink test model according to 3GPP TS 34.121 Release 6, Table C.10.1.4.

**TS34121\_R8\_Table\_C\_10\_1\_4\_Subtest3**

Uplink test models for transmitter characteristics tests with HS-DPCCH according to 3GPP TS 34.121 Release 8, Table C.10.1.4.

**TS34121\_R8\_Table\_C\_11\_1\_3\_Subtest2**

Uplink test models for transmitter characteristics tests with HS-DPCCH and E-DCH according to 3GPP TS 34.121 Release 8, Table C.11.1.3.

**TS34121\_R8\_Table\_C\_11\_1\_4\_Subtest1**

Uplink test model for transmitter characteristics tests with HS-DPCCH and E-DCH with 16QAM according to 3GPP TS 34.121 Release 8, Table C.11.1.4.

**Example:** `BB:W3GP:SETT:TMOD:MST 'DPCCH_DPDCH960ksps'`  
selects the test model with a symbol rate of 960 ksps.

**Manual operation:** See "[Test Models Uplink](#)" on page 63

**[:SOURce<hw>]:BB:W3Gpp:SETTing:TMODeI:MSTation:CATalog?**

The command queries the list of non-standardized test models for the uplink.

**Return values:**

<Catalog> string

**Example:**

`BB:W3GP:SETT:TMOD:MST:CAT?`

queries the list of available test models

Response: `DPCCH_DPDCH960ksps,DPCCH_DPDCH_60ksps`

**Usage:**

Query only

**Manual operation:** See "[Test Models Uplink](#)" on page 63

## 5.7 Setting base stations

The `SOURce:BB:W3Gpp:BSTation` system contains commands for setting base stations. The commands of this system only take effect if the 3GPP FDD standard is activated, the `DOWN` transmission direction is selected and the particular base station is enabled:

`SOURce:BB:W3Gpp:STATE ON`

`SOURce:BB:W3Gpp:LINK DOWN`

`SOURce:BB:W3Gpp:BSTation2:STATE ON`

**BSTation<st>**

The numeric suffix to `BSTation` determines the base station. The value range is 1 .. 4. If the suffix is omitted, BS1 is selected.

**CHANnel<ch>**



In case of remote control, suffix counting for channels corresponds to the suffix counting with 3GPP FDD (channel 0 to channel 138). SCPI prescribes that suffix 1 is the default state and used when no specific suffix is specified. Therefore, channel 1 (and not channel 0) is selected when no suffix is specified.

The commands for setting the enhanced channels of base station 1 are described in [Chapter 5.8, "Enhanced channels of base station 1"](#), on page 329.

---

**[ :SOURce<hw>]:BB:W3GPp:BSTation:OCNS:STATE <State>**

Activates OCNS channels according to the scenario selected with the command [ :SOURce<hw>]:BB:W3GPp:BSTation:OCNS:MODE.

**Parameters:**

<State>                    1 | ON | 0 | OFF  
 \*RST:                    0

**Example:**                See [ :SOURce<hw>]:BB:W3GPp:BSTation:OCNS:MODE on page 283.

**Manual operation:**    See "OCNS On" on page 71

---

**[ :SOURce<hw>]:BB:W3GPp:BSTation:OCNS:MODE <Mode>**

Selects the scenario for setting the OCNS channels.

To activate the selected scenario, send the command [ :SOURce<hw>]:BB:W3GPp:BSTation:OCNS:STATE.

**Parameters:**

<Mode>                    STANdard | HSDPa | HSDP2 | M3I  
 Four different OCNS scenarios are defined in the standard; one standard scenario, two scenarios for testing HSDPA channels and one for enhanced performance type 3i tests.  
 \*RST:                    STANdard

**Example:**                BB:W3GP:BST:OCNS:MODE HSDP  
 Selects the scenario for testing the high-speed channels.  
 BB:W3GP:BST:OCNS:STAT ON  
 Activates the OCNS channels with the settings defined in the standard.

**Manual operation:**    See "OCNS Mode" on page 71

---

**[ :SOURce<hw>]:BB:W3GPp:BSTation:OCNS:SEED <Seed>**

In "3i" OCNS mode, sets the seed for both the random processes, the power control simulation process and the process controlling the switch over of the channelization codes.

**Parameters:**

<Seed> integer  
 Range: 0 to 65535  
 \*RST: dynamic

**Manual operation:** See "[OCNS Seed](#)" on page 72

**[[:SOURce<hw>]:BB:W3GPp:BSTation<st>:CHANnel:HSDPa:HSET:PRESet**

Sets the default settings of the channel table for the HSDPA H-Set mode. Channels 12 to 17 are preset for HSDPA H-Set 1.

**Example:**

```
SOURce1:BB:W3GPp:BSTation1:CHANnel12:HSDPa:MODE
HSET
```

selects H-Set mode.

```
SOURce1:BB:W3GPp:BSTation1:CHANnel12:HSDPa:
HSET:PRES
```

presets the H-Set.

```
SOURce1:BB:W3GPp:BSTation1:CHANnel12:TYPE?
```

Response: HSSC

```
SOURce1:BB:W3GPp:BSTation1:CHANnel12:HSDPa:
HSET:PREDefined?
```

Response: P1QPSK

**Usage:** Event

**Manual operation:** See "[Preset HSDPA H-Set](#)" on page 73

**[[:SOURce<hw>]:BB:W3GPp:BSTation<st>:CHANnel:PRESet**

The command calls the default settings of the channel table.

**Example:**

```
BB:W3GP:BST:CHAN:PRES
```

presets all channels of the base station.

**Usage:** Event

**Manual operation:** See "[Reset All Channels](#)" on page 73

**[[:SOURce<hw>]:BB:W3GPp:BSTation<st>:CHANnel<ch0>:AICH:ASLOt <ASlot>**

Selects the slot in which the burst is transmitted.

**Suffix:**

<ch0> 7..7

**Parameters:**

<ASlot> integer  
 Range: 0 to 15  
 \*RST: 0

**Example:**                   SOURce1:BB:W3GPp:BSTation1:CHANnel7:AICH:ASLOt  
5  
defines the slot to transmit the burst.

**Manual operation:** See ["Access Slot"](#) on page 131

**[:SOURce<hw>]:BB:W3GPp:BSTation<st>:CHANnel<ch0>:AICH:SAPattern  
<SaPattern>**

Enters the 16 bit pattern for the ACK/NACK field.

**Parameters:**

<SaPattern>                   <16 bit pattern>  
\*RST:                   +000000000000

**Example:**                   SOURce1:BB:W3GPp:BSTation1:CHANnel<ch0>:AICH:  
SAPattern "+000000000000"  
sets the bit pattern to "+000000000000" (ACK).

**Manual operation:** See ["Signature ACK/NACK Pattern"](#) on page 130

**[:SOURce<hw>]:BB:W3GPp:BSTation<st>:CHANnel<ch0>:APAIch:ASLOt  
<ASlot>**

Selects the slot in which the burst is transmitted.

**Suffix:**

<ch0>                   8..8

**Parameters:**

<ASlot>                   integer  
Range:                   0 to 15  
\*RST:                   0

**Example:**                   SOURce1:BB:W3GPp:BSTation1:CHANnel8:APAIch:  
ASLOt 5  
defines the slot to transmit the burst.

**Manual operation:** See ["Access Slot"](#) on page 131

**[:SOURce<hw>]:BB:W3GPp:BSTation<st>:CHANnel<ch0>:APAIch:SAPattern  
<SaPattern>**

Enters the 16-bit pattern for the ACK/NACK field.

This field is used by the base station to acknowledge, refuse or ignore requests of up to 16 user equipment.

**Parameters:**

<SaPattern>                   <16 bit pattern>  
\*RST:                   "+000000000000"

**Example:** SOUR:BB:W3GP:BST1:CHAN8:APAI:SAP  
"+000000000000"  
Sets the bit pattern to "+" (ACK).

**Manual operation:** See "[Signature ACK/NACK Pattern](#)" on page 130

**[ :SOURce<hw>]:BB:W3GPp:BSTation<st>:CHANnel<ch0>:CCODE <CCode>**

The command sets the channelization code (formerly the spreading code number). The range of values of the channelization code depends on the symbol rate of the channel. The standard assigns a fixed channelization code to some channels (P-CPICH, for example, always uses channelization code 0).

$[\text{chip-rate}(=3.84\text{Mcps}) / \text{symbol\_rate}] - 1$

The slot format determines the symbol rate (and thus the range of values for the channelization code), the TFCI state and the pilot length. If the value of any one of the four parameters is changed, all the other parameters are adapted as necessary.

In the case of enhanced channels with active channel coding, the selected channel coding also affects the slot format and thus the remaining parameters. If these parameters are changed, the channel coding type is set to user.

**Parameters:**

<CCode> integer  
Range: 0 to 511  
Increment: 1  
\*RST: depends on channel type

**Example:** BB:W3GP:BST1:CHAN15:CCOD 123  
Sets channelization code 123 for channel 15 of base station 1.

**Manual operation:** See "[Channelization Code](#)" on page 75

**[ :SOURce<hw>]:BB:W3GPp:BSTation<st>:CHANnel<ch0>:DATA <Data>**

The command determines the data source for the data fields of the specified channel.

For enhanced channels with channel coding, the data source is set with the command [\[:SOURce<hw>\]:BB:W3GPp:BSTation:ENHanced:CHANnel<ch0>:DPCH:TCHannel<di0>:DATA](#) on page 338.

**Parameters:**

<Data> PN9 | PN11 | PN15 | PN16 | PN20 | PN21 | PN23 | DLISt | ZERO | ONE | PATTErn

**PNxx**

The pseudo-random sequence generator is used as the data source. Different random sequence lengths can be selected.

**DLISt**

A data list is used. The data list is selected with the command `:BB:W3GPp:BST:CHANnel:DATA:DSElect.`

**ZERO | ONE**

Internal 0 and 1 data is used.

**PATtern**

Internal data is used. The bit pattern for the data is defined by the command `:BB:W3GPp:BST:CHANnel:DATA:PATtern`.

\*RST: PN9

**Example:**

```
BB:W3GP:BST2:CHAN13:DATA PATT
```

Selects as the data source for the data fields of channel 13 of base station 2, the bit pattern defined with the following command.

```
BB:W3GP:BST2:CHAN13:DATA:PATT #H3F,8
```

Defines the bit pattern.

**Manual operation:** See ["Data"](#) on page 76

```
[:SOURce<hw>]:BB:W3GPp:BSTation<st>:CHANnel<ch0>:DATA:DSElect
<DSelect>
```

The command selects the data list for the DLIS data source selection.

The lists are stored as files with the fixed file extensions `*.dm_iqd` in a directory of the user's choice. The directory applicable to the following commands is defined with the command `MMEMoRY:CDIR`. To access the files in this directory, you only have to give the file name, without the path and the file extension.

**Parameters:**

<DSelect> string

**Example:**

```
BB:W3GP:BST2:CHAN13:DATA DLIS
```

selects the Data Lists data source.

```
MMEMoRY:CDIR '/var/user/temp/IqData'
```

selects the directory for the data lists.

```
BB:W3GP:BST2:CHAN13:DATA:DSEL '3gpp_list1'
```

selects file '3gpp\_list1' as the data source. This file must be in the directory `/var/user/temp/IqData` and have the file extension `*.dm_iqd`.

**Manual operation:** See ["Data"](#) on page 76

```
[:SOURce<hw>]:BB:W3GPp:BSTation<st>:CHANnel<ch0>:DATA:PATtern
<Pattern>, <BitCount>
```

The command determines the bit pattern for the PATtern selection. The maximum length is 64 bits.

**Parameters:**

<Pattern> numeric

\*RST: #H0

<BitCount> integer  
 Range: 1 to 64  
 \*RST: 1

**Example:** BB:W3GP:BST2:CHAN13:DATA:PATT #H3F,8  
 defines the bit pattern.

**Manual operation:** See "Data" on page 76

**[[:SOURce<hw>]:BB:W3GPp:BSTation<st>:CHANnel<ch0>:DPCCh:MCODE  
 <MCode>**

The command activates multicode transmission for the selected channel (ON) or deactivates it (OFF). The multicode channels are destined for the same receiver, that is to say, are part of a radio link. The first channel of this group is used as the master channel. The common components (Pilot, TPC and TCFI) for all the channels are then spread using the spreading code of the master channel.

**Parameters:**

<MCode> 1 | ON | 0 | OFF  
 \*RST: 0

**Example:** BB:W3GP:BST2:CHAN12:DPCC:MCOD ON  
 activates the simulation in multicode mode for channel 12 of base station 2.  
 BB:W3GP:BST2:CHAN13:DPCC:MCOD ON  
 activates the simulation in multicode mode for channel 13 of base station 2. Channel 12 is the master channel.

**Manual operation:** See "Multicode State (DPCCH)" on page 133

**[[:SOURce<hw>]:BB:W3GPp:BSTation<st>:CHANnel<ch0>:DPCCh:PLENgtH  
 <PLength>**

Sets the length of the pilot fields.

The range of values for this parameter depends on the channel type and the symbol rate. The slot format determines the symbol rate (and thus the range of values for the channelization code), the TFCI state and the pilot length. If the value of any one of the four parameters is changed, all the other parameters are adapted as necessary.

In the case of enhanced channels with active channel coding, the selected channel coding also affects the slot format and thus the remaining parameters. If these parameters are changed, the channel coding type is set to user.

**Parameters:**

<PLength> BIT2 | BIT4 | BIT8 | BIT16 | BIT0  
 \*RST: BIT4, bei S-CCPCH 0

**Example:** SOURce1:W3GPp:BSTation1:CHANnel12:DPCC:PLENgtH  
 BIT8  
 Sets the length of the pilot fields for channel 12 of base station 1.



**Manual operation:** See "[Pilot Length](#)" on page 129

---

```
[ :SOURce<hw>]:BB:W3GPp:BSTation<st>:CHANnel<ch0>:DPCCh:POFFset:PILot
<Pilot>
```

Sets an offset to the set channel power for the pilot field.

**Parameters:**

```
<Pilot>          float
                  Range:   -10 to 10
                  Increment: 0.01
                  *RST:    0
```

**Example:** BB:W3GP:BST2:CHAN12:DPCC:POFF:PIL -2 dB  
in the pilot field, sets an offset of -2 dB relative to the channel power.

**Manual operation:** See "[Power Offset Pilot \(DPCCH\)](#)" on page 137

---

```
[ :SOURce<hw>]:BB:W3GPp:BSTation<st>:CHANnel<ch0>:DPCCh:POFFset:TFCI
<Tfci>
```

The command sets an offset to the set channel power for the TFCI field.

**Parameters:**

```
<Tfci>          float
                  Range:   -10 to 10
                  Increment: 0.01
                  *RST:    0
```

**Example:** BB:W3GP:BST2:CHAN12:DPCC:POFF:PIL -2 dB  
in the TFCI field, sets an offset of -2 dB relative to the channel power.

**Manual operation:** See "[Power Offset TFCI \(DPCCH\)](#)" on page 138

---

```
[ :SOURce<hw>]:BB:W3GPp:BSTation<st>:CHANnel<ch0>:DPCCh:POFFset:TPC
<Tpc>
```

The command sets an offset to the set channel power for the TPC field.

This setting is only valid for the DPCHs.

**Parameters:**

```
<Tpc>          float
                  Range:   -10 to 10
                  Increment: 0.01
                  *RST:    0
```

**Example:** BB:W3GP:BST2:CHAN12:DPCC:POFF:TPC -2 dB  
in the TPC field, sets an offset of -2 dB relative to the channel power.

**Manual operation:** See ["Power Offset TPC \(DPCCH\)"](#) on page 138

**[:SOURce<hw>]:BB:W3GPp:BSTation<st>:CHANnel<ch0>:DPCCh:TFCI <Tfci>**

The command enters the value of the TFCI field (Transport Format Combination Indicator) for the selected channel of the specified base station. The TFCI field is always filled with exactly 10 bits with leading zeros.

**Parameters:**

<Tfci> integer  
 Range: 0 to 1023  
 \*RST: 0

**Example:** BB:W3GP:BST2:CHAN12:DPCC:TFCI 22  
 sets the value 22 for the TFCI field of channel 12 of base station 2.

**Manual operation:** See ["TFCI Value"](#) on page 129

**[:SOURce<hw>]:BB:W3GPp:BSTation<st>:CHANnel<ch0>:DPCCh:TFCI:STATe <State>**

The command activates the TFCI field (Transport Format Combination Identifier) for the selected channel of the specified base station.

The slot format determines the symbol rate (and thus the range of values for the channelization code), the TFCI state and the pilot length. If the value of any one of the four parameters is changed, all the other parameters are adapted as necessary.

In the case of enhanced channels with active channel coding, the selected channel coding also affects the slot format and thus the remaining parameters. If these parameters are changed, the channel coding type is set to user.

**Parameters:**

<State> ON | OFF  
 \*RST: OFF

**Example:** BB:W3GP:BST2:CHAN12:DPCC:TFCI:STAT OFF  
 Sets that the TFCI field of channel 12 of base station 2 is not used.

**Manual operation:** See ["Use TFCI"](#) on page 129

**[:SOURce<hw>]:BB:W3GPp:BSTation<st>:CHANnel<ch0>:DPCCh:TPC:DATA <Data>**

Determines the data source for the TPC field of the channel.

**Parameters:**

<Data> ZERO | ONE | PATtern | DLISt

**DLISt**

A data list is used.

Use the command `[ :SOURce<hw> ] :BB:W3GPp:BSTation<st>:CHANnel<ch0>:DPCCh:TPC:DATA:DSElect` to define the data list file.

**ZERO | ONE**

Internal 0 and 1 data is used.

**PATtern**

Internal data is used. Use the command `[ :SOURce<hw> ] :BB:W3GPp:BSTation<st>:CHANnel<ch0>:DPCCh:TPC:DATA:PATtern` to define the bit pattern.

\*RST: ZERO

**Example:**

```
SOURce1:BB:W3GPp:BSTation2:CHANnel13:DPCCh:TPC:
DATA PATtern
```

Selects as the data source for the TPC field of channel 13 of base station 2

```
SOURce1:BB:W3GPp:BSTation2:CHANnel13:DPCCh:TPC:
DATA:PATtern #H3F,8
```

Defines the bit pattern.

**Example:**

```
SOURce1:BB:W3GPp:BSTation2:CHANnel13:DPCCh:TPC:
DATA DLIS
```

Selects the data source.

```
MMEM:CDIR '/var/user/IqData'
```

Selects the directory for the data lists.

```
SOURce1:BB:W3GPp:BSTation2:CHANnel13:DPCCh:TPC:
DATA:DSElect 'tpc_ch4'
```

Selects the file `tpc_ch4` as the data source.

**Manual operation:** See ["TPC Data Source \(DPCCH\)"](#) on page 134

**[ :SOURce<hw> ] :BB:W3GPp:BSTation<st>:CHANnel<ch0>:DPCCh:TPC:DATA:DSElect <DSelect>**

Selects the data list for the `DLISt` data source selection.

The lists are stored as files with the fixed file extensions `*.dm_iqd` in a directory of the user's choice. The directory is defined with the command `MMEMory:CDIR`. To access the files in this directory, you only have to give the file name, without the path and the file extension.

**Parameters:**

<DSelect>                      <data list name>

**Example:**

see `[ :SOURce<hw> ] :BB:W3GPp:BSTation<st>:CHANnel<ch0>:DPCCh:TPC:DATA` on page 290

**Manual operation:** See ["TPC Data Source \(DPCCH\)"](#) on page 134

---

```
[ :SOURce<hw>]:BB:W3GPP:BSTation<st>:CHANnel<ch0>:DPCCh:TPC:DATA:
  PATtern <Pattern>, <BitCount>
```

Determines the bit pattern.

**Parameters:**

<Pattern>	numeric
	*RST: #H0
<BitCount>	integer
	Range: 1 to 64
	*RST: 1

**Example:** see [\[:SOURce<hw>\]:BB:W3GPP:BSTation<st>:CHANnel<ch0>:DPCCh:TPC:DATA](#) on page 290

**Manual operation:** See ["TPC Data Source \(DPCCH\)"](#) on page 134

---

```
[ :SOURce<hw>]:BB:W3GPP:BSTation<st>:CHANnel<ch0>:DPCCh:TPC:MISuse
  <MisUse>
```

The command activates "mis-" use of the TPC field (Transmit Power Control) of the selected channel for controlling the channel powers of these channels of the specified base station.

The bit pattern (see commands [:W3GPP:BSTation<n>:CHANnel<n>:DPCCh:TPC...](#)) of the TPC field of each channel is used to control the channel power. A "1" leads to an increase of channel powers, a "0" to a reduction of channel powers. Channel power is limited to the range 0 dB to -60 dB. The step width of the change is defined with the command [\[:SOURce<hw>\]:BB:W3GPP:BSTation<st>:CHANnel<ch0>:DPCCh:TPC:PSTep](#).

**Parameters:**

<MisUse>	ON   OFF
	*RST: 0

**Manual operation:** See ["Misuse TPC for Output Power Control \(DPCCH\)"](#) on page 136

---

```
[ :SOURce<hw>]:BB:W3GPP:BSTation<st>:CHANnel<ch0>:DPCCh:TPC:PSTep
  <PowerStep>
```

The command defines the step width for the change of channel powers in the case of "mis-" use of the TPC field.

**Parameters:**

<PowerStep>	float
	Range: -10 to 10
	Increment: 0.01
	*RST: 0

**Example:** `BB:W3GP:BST2:CHAN13:DPCC:TPC:PST 1 dB`  
sets the step width for the change of channel powers for channel 13 of base station 2 to 1 dB.

**Manual operation:** See ["TPC Power Step \(DPCCH\)"](#) on page 136

**[:SOURce<hw>]:BB:W3GPP:BSTation<st>:CHANnel<ch0>:DPCCh:TPC:READ**  
<Read>

The command sets the read out mode for the bit pattern of the TPC field.

The bit pattern is defined with the commands `:BB:W3GPP:BST<i>:CHANnel<n>:DPCCh:TPC...`

**Parameters:**

<Read> CONTInuous | S0A | S1A | S01A | S10A

**CONTInuous**

The bit pattern is used cyclically.

**S0A**

The bit pattern is used once, then the TPC sequence continues with 0 bits.

**S1A**

The bit pattern is used once, then the TPC sequence continues with 1 bit.

**S01A**

The bit pattern is used once and then the TPC sequence is continued with 0 bits and 1 bit alternately (in multiples, depending on by the symbol rate, for example, 00001111).

**S10A**

The bit pattern is used once and then the TPC sequence is continued with 1 bit and 0 bits alternately (in multiples, depending on by the symbol rate, for example, 11110000).

\*RST: CONTInuous

**Example:** `BB:W3GP:BST2:CHAN13:DPCC:TPC:READ S0A`  
The bit pattern is used once, after which a 0 sequence is generated (applies to channel 13 of base station 2).

**Manual operation:** See ["TPC Read Out Mode \(DPCCH\)"](#) on page 135

**[:SOURce<hw>]:BB:W3GPP:BSTation<st>:CHANnel<ch0>:FDPCh:DPCCh:TPC:**  
**DATA** <Data>

The command determines the data source for the TPC field of the channel.

**Parameters:**

<Data> DLISt | ZERO | ONE | PATTErn

**DLISt**

A data list is used. The data list is selected with the command

```
[ :SOURce<hw> ] :BB:W3GPp:BSTation<st> :
CHANnel<ch0> :FDPCCh:DPCCCh:TPC:DATA:DSElect
```

**ZERO | ONE**

Internal 0 and 1 data is used.

**PATtern**

Internal data is used. The bit pattern for the data is defined by the command [ :SOURce<hw> ] :BB:W3GPp:BSTation<st> : CHANnel<ch0> :FDPCCh:DPCCCh:TPC:DATA:PATtern.

```
*RST:      PATtern
```

**Example:**

```
BB:W3GP:BST1:CHAN11:FDPC:DPCC:TPC:DATA PATT
selects as the data source for the TPC field of channel 11 of
base station 1, the bit pattern defined with the following com-
mand:
```

```
BB:W3GP:BST1:CHAN11:FDPC:DPCC:TPC:DATA: PATT
#H3F, 8
```

defines the bit pattern.

**Manual operation:** See "TPC Source" on page 143

```
[ :SOURce<hw> ] :BB:W3GPp:BSTation<st> :CHANnel<ch0> :FDPCCh:DPCCCh:TPC:
DATA:DSElect <DSelect>
```

The command selects the data list for the DLISt data source selection.

The lists are stored as files with the fixed file extensions \*.dm\_iqd in a directory of the user's choice. The directory applicable to the following commands is defined with the command MMEMoRY:CDIR. To access the files in this directory, you only have to give the file name, without the path and the file extension.

**Parameters:**

```
<DSelect>      <data list name>
```

**Example:**

```
BB:W3GP:BST1:CHAN11:FDPC:DPCC:TPC:DATA DLIS
selects the "Data Lists" data source.
```

```
MMEM:CDIR '/var/user/temp/IqData'
```

selects the directory for the data lists.

```
BB:W3GP:BST1:CHAN11:FDPC:DPCC:TPC:DATA:DSEL
'tpc_ch4'
```

selects the file 'tpc\_ch4' as the data source. This file must be in the directory /var/user/temp/IqData and have the file extension \*.dm\_iqd.

**Manual operation:** See "TPC Source" on page 143

---

```
[ :SOURce<hw>]:BB:W3GPp:BSTation<st>:CHANnel<ch0>:FDPCh:DPCCCh:TPC:
  DATA:PATtern <Pattern>, <BitCount>
```

The command determines the bit pattern for the PATtern selection. The maximum bit pattern length is 32 bits.

**Parameters:**

```
<Pattern>          numeric
                   *RST:      #H0

<BitCount>        integer
                   Range:     1 to 64
                   *RST:      1
```

**Example:**

```
BB:W3GP:BST1:CHAN11:FDPCh:DPCCCh:TPC:DATA:PATT
#H3F, 8
```

defines the bit pattern for the TPC field of channel 11 of base station 1.

**Manual operation:** See ["TPC Source"](#) on page 143

---

```
[ :SOURce<hw>]:BB:W3GPp:BSTation<st>:CHANnel<ch0>:FDPCh:DPCCCh:TPC:
  MISuse <Misuse>
```

The command activates "mis-" use of the TPC field (Transmit Power Control) of the selected channel for controlling the channel powers of these channels of the specified base station.

The bit pattern (see command [\[:SOURce<hw>\]:BB:W3GPp:BSTation<st>:CHANnel<ch0>:FDPCh:DPCCCh:TPC:DATA:PATtern](#)) of the TPC field of each channel is used to control the channel power. A "1" leads to an increase of channel powers, a "0" to a reduction of channel powers. Channel power is limited to the range 0 dB to -60 dB. The step width of the change is defined with the command [\[:SOURce<hw>\]:BB:W3GPp:BSTation<st>:CHANnel<ch0>:FDPCh:DPCCCh:TPC:PSTep](#).

**Parameters:**

```
<Misuse>          ON | OFF
                   *RST:      0
```

**Example:**

```
BB:W3GP:BST1:CHAN11:FDPCh:DPCCCh:TPC:MIS ON
```

activates regulation of channel power for channel 11 of base station 1 via the bit pattern of the associated TPC field.

```
BB:W3GP:BST1:CHAN11:FDPCh:DPCCCh:TPC:PST 1dB
```

sets the step width for the change of channel powers for channel 11 of base station 1 to 1 dB.

**Manual operation:** See ["TPC For Output Power Control \(Mis-\) Use"](#) on page 144

---

```
[ :SOURce<hw>]:BB:W3GPp:BSTation<st>:CHANnel<ch0>:FDPCCh:DPCCCh:TPC:
PSTep <PStep>
```

The command defines the step width for the change of channel powers in the case of "mis-" use of the TPC field.

**Suffix:**

<ch0> 11..138

**Parameters:**

<PStep> float  
 Range: -10.0 dB to 10.0 dB  
 Increment: 0.01 dB  
 \*RST: 0 dB

**Example:**

BB:W3GP:BST1:CHAN11:FDPC:DPCC:TPC:PST 1.5dB  
 sets the step width for the change of channel powers for channel 11 of base station 1 to 1.5 dB.

**Manual operation:** See ["TPC Power Step \(F-DPCH\)"](#) on page 145

---

```
[ :SOURce<hw>]:BB:W3GPp:BSTation<st>:CHANnel<ch0>:FDPCCh:DPCCCh:TPC:
READ <Read>
```

The command sets the read out mode for the bit pattern of the TPC field.

**Parameters:**

<Read> CONTInuous | S0A | S1A | S01A | S10A

**CONTInuous**

The bit pattern is used cyclically.

**S0A**

The bit pattern is used once, then the TPC sequence continues with 0 bits.

**S1A**

The bit pattern is used once, then the TPC sequence continues with 1 bit.

**S01A**

The bit pattern is used once and then the TPC sequence is continued with 0 bits and 1 bit alternately (in multiples, depending on by the symbol rate, for example, 00001111).

**S10A**

The bit pattern is used once and then the TPC sequence is continued with 1 bit and 0 bits alternately (in multiples, depending on by the symbol rate, for example, 11110000).

\*RST: CONTInuous

**Example:**

BB:W3GP:BST1:CHAN11:FDPC:DPCC:TPC:READ S0A  
 The bit pattern is used once, after which a 0 sequence is generated (applies to channel 11 of base station 1).

**Manual operation:** See ["TPC Read Out Mode \(F-DPCH\)"](#) on page 144



---

```
[ :SOURce<hw>]:BB:W3GPp:BSTation<st>:CHANnel<ch0>:HSDPa:BMODE[:
  STATE] <State>
```

The command activates/deactivates burst mode. The signal is bursted when on, otherwise dummy data are sent during transmission brakes.

**Parameters:**

```
<State>          ON | OFF
*RST:           1
```

**Example:**

```
BB:W3GP:BST1:CHAN12:HSDP:BMOD OFF
deactivates burst mode, dummy data are sent during the trans-
mission brakes.
```

**Manual operation:** See "[Burst Mode](#)" on page 89

---

```
[ :SOURce<hw>]:BB:W3GPp:BSTation<st>:CHANnel<ch0>:HSDPa:CVPB <Cvpb>
```

The command switches the order of the constellation points of the 16QAM and 64QAM mapping. The re-arrangement is done according to 3GPP TS25.212.

**Parameters:**

```
<Cvpb>          integer
Range:          0 to 3
*RST:           0
```

**Example:**

```
BB:W3GP:BST1:CHAN12:HSDP:CVPB 1
selects interchange of MSBs with LSBs.
```

**Manual operation:** See "[Constellation Version Parameter b - BS](#)" on page 90

---

```
[ :SOURce<hw>]:BB:W3GPp:BSTation<st>:CHANnel<ch0>:HSDPa:HSET:AMODE
  <AMode>
```

Activates/deactivates the advanced mode in which the H-Set is generated by the ARB.

The parameter can be configured only for H-Sets 1 - 5.

For H-Sets 6 to 12 and User, it is always enabled.

**Parameters:**

```
<AMode>         ON | OFF
*RST:           OFF (H-Sets 1..5); ON (H-Sets 6..12, User);
```

**Example:**

```
BB:W3GP:BST1:CHAN12:HSDP:MODE HSET
Selects H-Set mode.
BB:W3GP:BST1:CHAN12:HSDP:HSET:PREDEF P1QAM16
Selects H-Set 1 (16QAM).
BB:W3GP:BST1:CHAN12:HSDP:HSET:AMOD ON
Enables advanced mode for the selected H-Set.
```

**Manual operation:** See "[Advanced Mode \(requires ARB\)](#)" on page 94

---

**[ :SOURce<hw>]:BB:W3GPp:BSTation<st>:CHANnel<ch0>:HSDPa:HSET:  
ACLength <AcLength>**

Sets the alternative number of HS-PDSCH channelization codes (see [Chapter 3.13.9, "Randomly varying modulation and number of codes \(Type 3i\) settings"](#), on page 107).

**Parameters:**

<AcLength> integer  
 Range: 1 to 15 (max depends on other values)  
 \*RST: 5

**Example:** SOURce:BB:W3GP:BST1:CHANnel12:HSDPa:HSET:  
 CLEnGth 8  
 SOURce:BB:W3GP:BST1:CHANnel12:HSDPa:HSET:  
 AClengTh 8

**Manual operation:** See "[Alternative Number of HS-PDSCH Channelization Codes](#)" on page 109

---

**[ :SOURce<hw>]:BB:W3GPp:BSTation<st>:CHANnel<ch0>:HSDPa:HSET:  
ALTModulation <ALTModulation>**

Sets the alternative modulation (see [Chapter 3.13.9, "Randomly varying modulation and number of codes \(Type 3i\) settings"](#), on page 107).

**Parameters:**

<ALTModulation> QPSK | QAM16 | QAM64  
 \*RST: QAM16

**Example:** :SOURce:BB:W3GPp:BSTation1:CHANnel12:HSDPa:  
 HSET:ALTModulation QPSK

**Manual operation:** See "[Alternative HS-PDSCH Modulation](#)" on page 109

---

**[ :SOURce<hw>]:BB:W3GPp:BSTation<st>:CHANnel<ch0>:HSDPa:HSET:  
BCBTti<di>?**

Displays the binary channel bits per TTI and per stream.

The value displayed is calculated upon the values sets with the commands:

- `[ :SOURce<hw>]:BB:W3GPp:BSTation<st>:CHANnel<ch0>:HSDPa:HSET:MODulation<di>`,
- `[ :SOURce<hw>]:BB:W3GPp:BSTation<st>:CHANnel<ch0>:SRATe` and
- `[ :SOURce<hw>]:BB:W3GPp:BSTation<st>:CHANnel<ch0>:HSDPa:HSET:HSCCode`.

**Return values:**

<Bcbtti> float

**Example:** BB:W3GP:BST1:CHAN12:HSDP:MODE HSET  
selects H-Set mode.  
BB:W3GP:BST1:CHAN12:HSDP:HSET:TYPE MIMO  
sets the H-set type.  
BB:W3GP:BST1:CHAN12:HSDP:HSET:BCBT2?  
queries the binary channel bits per TTI for stream 2.  
Response: "4800"

**Usage:** Query only

**Manual operation:** See ["Binary Channel Bits per TTI \(Physical Layer\) Stream1/2"](#) on page 101

**[:SOURCE<hw>]:BB:W3GPp:BSTation<st>:CHANnel<ch0>:HSDPa:HSET:  
BPAYload<di>?**

The command queries the payload of the information bit. This value determines the number of transport layer bits sent in each subframe.

**Return values:**

<BPayload> float  
Range: 1 to 5000

**Example:** BB:W3GP:BST1:CHAN12:HSDP:MODE HSET  
selects H-Set mode.  
BB:W3GP:BST1:CHAN12:HSDP:HSET:BPAY2?  
queries the payload of the information bit.  
Response: "256"

**Usage:** Query only

**Manual operation:** See ["Information Bit Payload \(TB-Size\) Stream 1/2"](#) on page 102

**[:SOURCE<hw>]:BB:W3GPp:BSTation<st>:CHANnel<ch0>:HSDPa:HSET:  
CLENGTH <CLength>**

The command queries the number of physical HS-PDSCH data channels assigned to the HS-SCCH.

**Parameters:**

<CLength> integer  
Range: 1 to 15  
\*RST: 5

**Example:** BB:W3GP:BST1:CHAN12:HSDP:MODE HSET  
selects H-Set mode.  
BB:W3GP:BST1:CHAN12:HSDP:HSET:CLEN?  
queries the number of physical HS-PDSCH data channels assigned to the HS-SCCH.  
Response: "4"

**Manual operation:** See ["Number of HS-PDSCH Channelization Codes"](#) on page 99

---

```
[:SOURce<hw>]:BB:W3GPp:BSTation<st>:CHANnel<ch0>:HSDPa:HSET:
  CRATe<di>?
```

Queries the resulting coding rate per stream.

The coding rate is calculated as a relation between the "Information Bit Payload" and "Binary Channel Bits per TTI".

**Return values:**

<CRate> float

**Example:**

```
BB:W3GP:BST1:CHAN12:HSDP:MODE HSET
selects H-Set mode.
BB:W3GP:BST1:CHAN12:HSDP:HSET:CRAT2?
queries the coding rate of stream 2.
Response: "0.658"
```

**Usage:** Query only

**Manual operation:** See "[Coding Rate Stream 1/2](#)" on page 102

---

```
[:SOURce<hw>]:BB:W3GPp:BSTation<st>:CHANnel<ch0>:HSDPa:HSET:DATA
  <Data>
```

Selects the data source for the transport channel.

**Parameters:**

<Data> ZERO | ONE | PATtern | PN9 | PN11 | PN15 | PN16 | PN20 |  
PN21 | PN23 | DLISt

**ZERO | ONE**

Internal 0 and 1 data is used.

**PATtern**

Internal data is used. Use the command `[:SOURce<hw>]:BB:W3GPp:BSTation<st>:CHANnel<ch0>:HSDPa:HSET:DATA:PATtern` to set the pattern.

**DLISt**

A data list is used. Use the command `[:SOURce<hw>]:BB:W3GPp:BSTation<st>:CHANnel<ch0>:HSDPa:HSET:DATA:DSElect` to select the data list file.

```
*RST: PN9
```

**Example:**

```
BB:W3GP:BST1:CHAN11:HSDP:HSET:DATA PATT
selects as the data source for the transport channel
BB:W3GP:BST1:CHAN11:HSDP:HSET:DATA:PATT #H3F,8
defines the bit pattern.
```

**Manual operation:** See "[Data Source \(HS-DSCH\)](#)" on page 98

---

```
[:SOURce<hw>]:BB:W3GPp:BSTation<st>:CHANnel<ch0>:HSDPa:HSET:DATA:
  DSElect <DSelect>
```

The command selects the data list for the DLISt data source selection.

The lists are stored as files with the fixed file extensions `*.dm_iqd` in a directory of the user's choice. The directory applicable to the following commands is defined with the command `MMEMoRY:CDIR`. To access the files in this directory, you only have to give the file name, without the path and the file extension.

**Parameters:**

<DSelect>                    string

**Example:**

```
BB:W3GP:BST1:CHAN11:HSDP:HSET:DATA DLIS
selects the Data Lists data source.
MMEMoRY:CDIR '/var/user/temp/H-Sets'
selects the directory for the data lists.
BB:W3GP:BST1:CHAN11:HSDP:HSET:DATA:DSEL
'hset_ch11'
selects the file hset_ch11 as the data source. This file must be
in the directory /var/user/temp/H-Sets and have the file
extension *.dm_iqd.
```

**Manual operation:** See "[Data Source \(HS-DSCH\)](#)" on page 98

**[:SOURce<hw>]:BB:W3GPp:BSTation<st>:CHANnel<ch0>:HSDPa:HSET:DATA:  
PATtern <Pattern>, <BitCount>**

Determines the bit pattern for the `PATtern` selection.

**Parameters:**

<Pattern>                    numeric  
\*RST:                    #H0

<BitCount>                   integer  
Range:                    1 to 64  
\*RST:                    1

**Example:**

```
BB:W3GP:BST1:CHAN11:HSDP:HSET:DATA PATT
selects as the data source for the H-set
BB:W3GP:BST1:CHAN11:HSDP:HSET:DATA:PATT #H3F, 8
defines the bit pattern for the H-set.
```

**Manual operation:** See "[Data Source \(HS-DSCH\)](#)" on page 98

**[:SOURce<hw>]:BB:W3GPp:BSTation<st>:CHANnel<ch0>:HSDPa:HSET:HARQ:  
LENGth <Length>**

Sets the number of HARQ processes. This value determines the distribution of the payload in the subframes.

**Parameters:**

<Length>                    integer  
Range:                    1 to 6  
\*RST:                    0

**Example:**           SOURce1:BB:BB:W3GPP:BSTation1:CHANnel12:HSDPa:  
HSET:HARQ:MODE HSET  
selects H-Set mode.  
SOURce1:BB:BB:W3GPP:BSTation1:CHANnel12:HSDPa:  
HSET:HARQ:LENGth?  
queries the number of HARQ processes.  
Response: 2

**Manual operation:** See "[Number of HARQ Processes per Stream](#)" on page 104

**[[:SOURce<hw>]:BB:W3GPP:BSTation<st>:CHANnel<ch0>:HSDPa:HSET:HARQ:  
MODE <Mode>**

Sets the HARQ Simulation Mode.

**Parameters:**

<Mode>                   CACK | CNACK

**CACK**  
New data is used for each new TTI.

**CNACK**  
Enables NACK simulation, i.e. depending on the sequence selected for the parameter Redundancy Version Parameter Sequence packets are retransmitted.

\*RST:           CACK

**Example:**           BB:W3GP:BST1:CHAN12:HSDP:MODE HSET  
selects H-Set mode.  
BB:W3GP:BST1:CHAN12:HSDP:HSET:AMOD ON  
enables advanced mode.  
BB:W3GP:BST1:CHAN12:HSDP:HSET:HARQ:MODE CNAC  
sets Constant NACK HARQ Mode.

**Manual operation:** See "[Mode \(HARQ Simulation\)](#)" on page 105

**[[:SOURce<hw>]:BB:W3GPP:BSTation<st>:CHANnel<ch0>:HSDPa:HSET:  
HSCCode <HsCCode>**

Sets the channelization code of the HS-SCCH.

**Parameters:**

<HsCCode>               float  
Range:           0 to 127

**Example:**           BB:W3GP:BST1:CHAN12:HSDP:MODE HSET  
Selects H-Set mode.  
BB:W3GP:BST1:CHAN12:HSDP:HSET:HSCC 10  
Sets channelization code 10 for the HS-SCCH.

**Manual operation:** See "[Channelization Code HS-SCCH \(SF128\)](#)" on page 99

---

```
[ :SOURce<hw>]:BB:W3GPp:BSTation<st>:CHANnel<ch0>:HSDPa:HSET:
  MODulation<di> <Modulation>
```

Sets the modulation for stream 1 and stream 2 to QPSK, 16QAM or 64QAM.

For HS-SCCH Type 2, the available modulation scheme is QPSK only.

**Parameters:**

```
<Modulation>      QPSK | QAM16 | QAM64
                   *RST:      QPSK
```

**Example:**

```
BB:W3GP:BST1:CHAN12:HSDP:HSET:TYPE MIMO
BB:W3GP:BST1:CHAN12:HSDP:HSET:MOD1 QAM64
```

**Options:**

64QAM requires R&S SMBVB-K83

**Manual operation:** See "[HS-PDSCH Modulation Stream1/2](#)" on page 101

---

```
[ :SOURce<hw>]:BB:W3GPp:BSTation<st>:CHANnel<ch0>:HSDPa:HSET:
  NAIBitrate?
```

Queries the average data rate on the transport layer (Nominal Average Information Bitrate).

**Return values:**

```
<NaiBitrate>      float
                   Range:      1 to 5000
                   Increment:  0.1
                   *RST:      0
```

**Example:**

```
BB:W3GP:BST1:CHAN12:HSDP:MODE HSET
selects H-Set mode.
BB:W3GP:BST1:CHAN12:HSDP:HSET:NAIB?
queries the average data rate on the transport layer.
Response: "455"
```

**Usage:** Query only

**Manual operation:** See "[Nominal Average Information Bit Rate](#)" on page 95

---

```
[ :SOURce<hw>]:BB:W3GPp:BSTation<st>:CHANnel<ch0>:HSDPa:HSET:
  PREDefined <Predefined>
```

The command selects the H-Set and the modulation according to TS 25.101 Annex A.7.

**Parameters:**

```
<Predefined>      P1QPSK | P1QAM16 | P2QPSK | P2QAM16 | P3QPSK |
                   P3QAM16 | P4QPSK | P5QPSK | P6QPSK | P6QAM16 |
                   P7QPSK | P8QAM64 | P9QAM16QPSK | P10QPSK |
                   P10QAM16 | P11QAM64QAM16 | P12QPSK | USER
                   *RST:      P1QPSK
```

**Example:** BB:W3GP:BST1:CHAN12:HSDP:MODE HSET  
selects H-Set mode.  
BB:W3GP:BST1:CHAN12:HSDP:HSET:PREDEF P3QPSK  
selects H-Set 3 (QPSK).

**Manual operation:** See "Predefined H-Set" on page 93

**[:SOURCE<hw>]:BB:W3GP:BSTation<st>:CHANNEL<ch0>:HSDP:HSET:  
PWPATTERN <PwPattern>**

Sets the precoding weight parameter w2 for MIMO precoding.

The values of the weight parameters w1, w3 and w4 are calculated based on the value for w2 (see [Chapter 2.3.14, "MIMO in HSPA+"](#), on page 30).

**Parameters:**

<PwPattern> string  
\*RST: 0

**Example:** BB:W3GP:BST1:CHAN12:HSDP:HSET:PWP "0,1,3"  
selects the pattern.

**Manual operation:** See "Precoding Weight Pattern (w2)" on page 97

**[:SOURCE<hw>]:BB:W3GP:BSTation<st>:CHANNEL<ch0>:HSDP:HSET:  
RVPARAMETER<di> <RvParameter>**

The parameter is enabled for "HARQ Simulation Mode" set to Constant ACK.

The command sets the Redundancy Version Parameter. This value determines the processing of the Forward Error Correction and Constellation Arrangement (QAM16 and 64QAM modulation), see TS 25.212 4.6.2.

For HS-SCCH Type 2 (less operation), the Redundancy Version Parameter is always 0.

**Parameters:**

<RvParameter> integer  
Range: 0 to 7  
\*RST: 0

**Example:** BB:W3GP:BST1:CHAN12:HSDP:MODE HSET  
selects H-Set mode.  
BB:W3GP:BST1:CHAN12:HSDP:HSET:HARQ:MODE CACK  
sets Constant ACK HARQ Mode.  
BB:W3GP:BST1:CHAN12:HSDP:HSET:RVP 7  
sets the Redundancy Version Parameter to 7.  
BB:W3GP:BST1:TDIV ANT1  
enables transmit diversity  
BB:W3GP:BST1:CHAN12:HSDP:HSET:TYPE MIMO  
selects HS-SCCH Type 3 (MIMO).  
BB:W3GP:BST1:CHAN12:HSDP:HSET:RVP2 4  
sets the Redundancy Version Parameter of stream 2.



**Manual operation:** See "[Redundancy Version Stream1/2](#)" on page 105

---

**[:SOURCE<hw>]:BB:W3GPp:BSTation<st>:CHANnel<ch0>:HSDPa:HSET:RVPSequence<di> <RvpSequence>**

The parameter is enabled for "HARQ Simulation Mode" set to Constant NACK.

Enters a sequence of Redundancy Version Parameters per stream. The value of the RV parameter determines the processing of the Forward Error Correction and Constellation Arrangement (16/64QAM modulation), see TS 25.212 4.6.2.

The sequence has a length of maximum 30 values. The sequence length determines the maximum number of retransmissions. New data is used after reaching the end of the sequence.

For HS-SCCH Type 2 (less operation), the Redundancy Version Parameter Sequence is a read-only parameter.

**Parameters:**

<RvpSequence>      string

**Example:**

```
BB:W3GP:BST1:CHAN12:HSDP:MODE HSET
selects H-Set mode.
BB:W3GP:BST1:CHAN12:HSDP:HSET:AMOD ON
enables advanced mode.
BB:W3GP:BST1:CHAN12:HSDP:HSET:HARQ:MODE CNAC
sets Constant NACK HARQ Mode.
BB:W3GP:BST1:TDIV ANT1
enables transmit diversity
BB:W3GP:BST1:CHAN12:HSDP:HSET:TYPE MIMO
selects HS-SCCH Type 3 (MIMO).
BB:W3GP:BST1:CHAN12:HSDP:HSET:RVPS2
'0,1,3,2,0,1,2,3'
sets the Redundancy Version Parameter sequence of stream 2.
```

**Example:**

```
BB:W3GP:BST1:CHAN12:HSDP:HSET:TYPE LOP
selects HS-SCCH Type 2 (less operation).
BB:W3GP:BST1:CHAN12:HSDP:HSET:RVPS?
queries the Redundancy Version Parameter sequence.
Response: 0,3,4
```

**Manual operation:** See "[Redundancy Version Sequence Stream 1/2](#)" on page 106

---

**[:SOURCE<hw>]:BB:W3GPp:BSTation<st>:CHANnel<ch0>:HSDPa:HSET:RVState <RvState>**

Enables/disables the random variation of the modulation and number of codes (see [Chapter 3.13.9, "Randomly varying modulation and number of codes \(Type 3i\) settings"](#), on page 107).

**Parameters:**

<RvState>            1 | ON | 0 | OFF  
\*RST:                OFF

**Example:** `SOURce:BB:W3GPp:BST1:CHAN12:HSDPa:HSET:RVStAtE ON`

**Manual operation:** See ["Randomly Varying Modulation And Number Of Codes"](#) on page 109

**[:SOURce<hw>]:BB:W3GPp:BSTation<st>:CHANnel<ch0>:HSDPa:HSET:SEED <Seed>**

Sets the seed for the random process deciding between the four options (see [Chapter 3.13.9, "Randomly varying modulation and number of codes \(Type 3i\) settings"](#), on page 107).

**Parameters:**

<Seed> integer  
 Range: 0 to 65535  
 \*RST: 0 for path A, 1 for path B

**Example:** `SOURce:BB:W3GPp:BST1:CHANnel112:HSDPa:HSET:SEED 5`

**Manual operation:** See ["Random Seed"](#) on page 109

**[:SOURce<hw>]:BB:W3GPp:BSTation<st>:CHANnel<ch0>:HSDPa:HSET:S64Qam <S64qam>**

Enables/disables UE support of 64QAM.

This command is enabled only for HS-SCCH Type 1 (normal operation) and 16QAM modulation.

In case this parameter is disabled, i.e. the UE does not support 64QAM, the xccs,7 bit is used for channelization information.

**Parameters:**

<S64qam> ON | OFF  
 \*RST: OFF

**Example:** `BB:W3GP:BST1:CHAN12:HSDP:MODE HSET`  
 selects H-Set mode.  
`BB:W3GP:BST1:CHAN12:HSDP:HSET:TYPE NORM`  
 selects HS-SCCH Type 1 (normal operation).  
`BB:W3GP:BST1:CHAN12:HSDP:HSET:MOD QAM16`  
 sets 16QAM modulation.  
`BB:W3GP:BST1:CHAN12:HSDP:HSET:S64Q ON`  
 enables UE to support 64QAM

**Manual operation:** See ["UE Supports 64QAM"](#) on page 101

---

**[ :SOURce<hw>]:BB:W3GPp:BSTation<st>:CHANnel<ch0>:HSDPa:HSET:SCCode <SCcode>**

Sets the channelization code of the first HS-PDSCH channel in the H-Set. The channelization codes of the rest of the HS-PDSCHs in this H-Set are set automatically.

**Note:** To let the instrument generate a signal equal to the one generated by an instrument equipped with older firmware, set the same Channelization Codes as the codes used for your physical channels.

**Parameters:**

<SCcode>                    integer  
                                  Range:        1 to 15  
                                  \*RST:        8

**Example:**

BB:W3GP:BST1:CHAN12:HSDP:MODE HSET  
 Selects H-Set mode.  
 BB:W3GP:BST1:CHAN12:HSDP:HSET:SCC 10  
 Sets channelization code of the first HS-PDSCH.

**Manual operation:** See "[Start Channelization Code HS-PDSCH \(SF16\)](#)" on page 99

---

**[ :SOURce<hw>]:BB:W3GPp:BSTation<st>:CHANnel<ch0>:HSDPa:HSET: SLENgth?**

Queries the suggested ARB sequence length.

**Return values:**

<SLength>                    integer  
                                  Range:        1 to max

**Example:**

see [ :SOURce<hw>]:BB:W3GPp:BSTation<st>:  
[CHANnel<ch0>:HSDPa:HSET:SLENgth:ADJust](#)  
 on page 307

**Usage:**                      Query only

**Manual operation:** See "[Advanced Mode \(requires ARB\)](#)" on page 94  
 See "[ARB Seq Length](#)" on page 94

---

**[ :SOURce<hw>]:BB:W3GPp:BSTation<st>:CHANnel<ch0>:HSDPa:HSET: SLENgth:ADJust**

Sets the ARB sequence length to the suggested value.

**Example:**

```
BB:W3GP:BST1:CHAN12:HSDP:MODE HSET
selects H-Set mode.
BB:W3GP:BST1:CHAN12:HSDP:HSET:AMOD ON
enables advanced mode.
BB:W3GP:BST1:CHAN12:HSDP:HSET:SLEN?
queries the suggested ABR sequence length.
Response: 21
BB:W3GP:SLEN?
queries the current ABR sequence length.
Response: 12
BB:W3GP:BST1:CHAN12:HSDP:HSET:SLEN:ADJ
sets the ARB sequence length to the suggested value.
BB:W3GP:SLEN?
queries the current ABR sequence length.
Response: 21
```

**Usage:** Event

**Manual operation:** See ["Adjust"](#) on page 94

**[[:SOURce<hw>]:BB:W3GPp:BSTation<st>:CHANnel<ch0>:HSDPa:HSET:SPATtern<di>?**

Queries the distribution of packets over time. A "-" indicates no packet

**Return values:**

<SPattern> string

**Example:**

```
BB:W3GP:BST1:CHAN15:HSDP:TTID 3
sets the TTI
BB:W3GP:BST1:CHAN12:HSDP:HSET:HARQ:LENG 2
sets the number of HARQ processes
BB:W3GP:BST1:CHAN12:HSDP:HSET:SPAT1?
queries the signaling pattern for stream 1
Response: 0,-,-1,-,-
```

**Usage:** Query only

**Manual operation:** See ["Signaling Pattern Stream1/2"](#) on page 104

**[[:SOURce<hw>]:BB:W3GPp:BSTation<st>:CHANnel<ch0>:HSDPa:HSET:STAPattern <StaPattern>**

Enables/disables a temporal deactivation of Stream 2 per TTI in form of sending pattern.

The stream 2 sending pattern is a sequence of max 16 values of "1" (enables Stream 2 for that TTI) and "-" (disabled Stream 2 for that TTI).

**Parameters:**

<StaPattern> string  
\*RST: 1

**Example:** BB:W3GP:BST1:CHAN12:HSDP:HSET:STAP "11-"  
selects the pattern.

**Manual operation:** See "[Stream 2 Active Pattern](#)" on page 97

**[ :SOURce<hw>]:BB:W3GPp:BSTation<st>:CHANnel<ch0>:HSDPa:HSET:TPOWer  
<Tpower>**

Sets the total power of the HS-PDSCH channels in the H-Set.

The individual power levels of the HS-PDSCHs are calculated automatically and can be queried with the command `[ :SOURce<hw>]:BB:W3GPp:BSTation<st>:CHANnel<ch0>:POWer`.

**Parameters:**

<Tpower> float

The min/max values depend on the number of HS-PDSCH channelization codes (`[ :SOURce<hw>]:BB:W3GPp:BSTation<st>:CHANnel<ch0>:HSDPa:HSET:CLENgth`) and are calculated as follow:

min = -80 dB + 10\*log<sub>10</sub>(NumberOfHS-PDSCHChannelizationCodes)

max = 0 dB + 10\*log<sub>10</sub>(NumberOfHS-PDSCHChannelizationCodes)

Range: dynamic to dynamic

Increment: 0.01

\*RST: -13.01

**Example:**

```
:SOURce:BB:W3GPp:BST1:CHAN12:HSDPa:MODE HSET
:SOURce:BB:W3GPp:BST1:CHAN12:HSDPa:HSET:
CLENgth?
Response: 5
:SOURce:BB:W3GPp:BST1:CHAN13:POWer -10
:SOURce:BB:W3GPp:BST1:CHAN12:HSDPa:HSET:TPOWer?
Response: -3.01029995663981 dB
:SOURce:BB:W3GPp:BST1:CHAN12:HSDPa:HSET:TPOWer
-5
:SOURce:BB:W3GPp:BST1:CHAN13:POWer?
Response: -11.9897000433602 dB
```

**Manual operation:** See "[Total HS-PDSCH Power](#)" on page 99

**[ :SOURce<hw>]:BB:W3GPp:BSTation<st>:CHANnel<ch0>:HSDPa:HSET:TBS:  
INDEX<di> <Index>**

Selects the Index ki for the corresponding table and stream, as described in 3GPP TS 25.321.

**Parameters:**

<Index> integer

Range: 0 to 62

**Example:** BB:W3GP:BST1:CHAN12:HSDP:MODE HSET  
Selects H-Set mode.  
BB:W3GP:BST1:CHAN12:HSDP:HSET:TBS:TABL2 TAB0  
Selects Table 0 for stream 2.  
BB:W3GP:BST1:CHAN12:HSDP:HSET:TBS:IND2 25  
Sets the Index ki

**Manual operation:** See "[Transport Block Size Index Stream1/2](#)" on page 102

**[:SOURce<hw>]:BB:W3GPp:BSTation<st>:CHANnel<ch0>:HSDPa:HSET:TBS:REFerence <Reference>**

While working in less operation mode, this command is signaled instead of the command BB:W3GP:BST:CHAN:HSDP:HSET:TBS:IND.

**Parameters:**  
<Reference> integer  
Range: 0 to 3  
\*RST: 0

**Example:** BB:W3GP:BST1:CHAN12:HSDP:MODE HSET  
selects H-Set mode.  
BB:W3GP:BST1:CHAN12:HSDP:HSET:TYPE LOP  
selects less operation mode.  
BB:W3GP:BST1:CHAN12:HSDP:HSET:TBS:TABL2 TAB0  
selects Table 0 for stream 2.  
BB:W3GP:BST1:CHAN12:HSDP:HSET:TBS:REF 2  
sets the reference.

**Manual operation:** See "[Transport Block Size Reference Stream1/2](#)" on page 102

**[:SOURce<hw>]:BB:W3GPp:BSTation<st>:CHANnel<ch0>:HSDPa:HSET:TBS:TABLE<di> <Table>**

Selects Table 0 or Table 1 as described in 3GPP TS 25.321.

For HS-PDSCH Modulation set to 64QAM, only Table 1 is available.

**Parameters:**  
<Table> TAB0 | TAB1  
\*RST: TAB0

**Example:** BB:W3GP:BST1:CHAN12:HSDP:MODE HSET  
Selects H-Set mode.  
BB:W3GP:BST1:CHAN12:HSDP:HSET:TBS:TABL2 TAB0  
Selects Table 0 for stream 2.

**Manual operation:** See "[Transport Block Size Table Stream1/2](#)" on page 102

---

```
[:SOURce<hw>]:BB:W3GPp:BSTation<st>:CHANnel<ch0>:HSDPa:HSET:TYPE
<Type>
```

Sets the HS-SCCH type.

**Parameters:**

```
<Type>          NORMal | LOPeration | MIMO
```

**NORMal**  
Normal operation mode.

**LOPeration**  
HS-SCCH less operation mode.

**MIMO**  
HS-SCCH Type 3 mode is defined for MIMO operation. Enabling this operation mode, enables the MIMO parameters [ :SOURce<hw>]:BB:W3GPp:BSTation<st>:CHANnel<ch0>:HSDPa:MIMO:CVPB<di>, [ :SOURce<hw>]:BB:W3GPp:BSTation<st>:CHANnel<ch0>:HSDPa:MIMO:MODulation<di>, [ :SOURce<hw>]:BB:W3GPp:BSTation<st>:CHANnel<ch0>:HSDPa:MIMO:PWPattern and [ :SOURce<hw>]:BB:W3GPp:BSTation<st>:CHANnel<ch0>:HSDPa:MIMO:STAPattern and all Stream 2 parameters.

\*RST:          NORMal

**Example:**          BB:W3GP:BST1:TDIV ANT1  
enables transmit diversity and antenna 1.  
BB:W3GP:BST1:CHAN12:HSDP:HSET:TYPE MIMO  
sets MIMO operation mode.

**Manual operation:** See "[HS-SCCH Type](#)" on page 95

---

```
[:SOURce<hw>]:BB:W3GPp:BSTation<st>:CHANnel<ch0>:HSDPa:HSET:
UECategory?
```

Queries the UE category number.

**Return values:**

```
<UeCategory>    integer
Range:          0 to 5000
```

**Example:**          BB:W3GP:BST1:CHAN12:HSDP:MODE HSET  
selects H-Set mode.  
BB:W3GP:BST1:CHAN12:HSDP:HSET:PRED P3QPSK  
selects H-Set 3 (QPSK).  
BB:W3GP:BST1:CHAN12:HSDP:HSET:UEC?  
queries the UE Category.  
Response: 5

**Usage:**            Query only

**Manual operation:** See "[UE Category](#)" on page 95

---

```
[ :SOURce<hw>]:BB:W3GPp:BSTation<st>:CHANnel<ch0>:HSDPa:HSET:UEID
<Ueid>
```

The command sets the UE identity which is the HS-DSCH Radio Network Identifier (H-RNTI) defined in 3GPP TS 25.331: "Radio Resource Control (RRC); Protocol Specification".

**Parameters:**

```
<Ueid>                integer
                        Range:    0 to 65535
                        *RST:    0
```

**Example:**

```
BB:W3GP:BST1:CHAN12:HSDP:MODE HSET
selects H-Set mode.
BB:W3GP:BST1:CHAN12:HSDP:HSET:UEID 256
sets the UE identity.
```

**Manual operation:** See "[UEID \(H-RNTI\)](#)" on page 99

---

```
[ :SOURce<hw>]:BB:W3GPp:BSTation<st>:CHANnel<ch0>:HSDPa:HSET:
VIBSize<di> <VibSize>
```

Sets the size of the Virtual IR Buffer (Number of SMLs per HARQ-Process) per stream.

**Parameters:**

```
<VibSize>             integer
                        Range:    800 to 304000
                        Increment: 800
                        *RST:    9600
```

**Example:**

```
SOURce1:BB:W3GPp:BSTation1:TDIV ANT1
SOURce1:BB:W3GPp:BSTation1:CHANnel12:HSDPa:
HSET:TYPE MIMO
SOURce1:BB:W3GPp:BSTation1:CHANnel12:HSDPa:
HSET:VIBSize1?
Response: 9600
SOURce1:BB:W3GPp:BSTation1:CHANnel12:HSDPa:
HSET:VIBSize1 300000
SOURce1:BB:W3GPp:BSTation1:CHANnel12:HSDPa:
HSET:VIBSize2 300000
```

**Manual operation:** See "[Virtual IR Buffer Size \(per HARQ Process\) Stream1/2](#)" on page 102

---

```
[ :SOURce<hw>]:BB:W3GPp:BSTation<st>:CHANnel<ch0>:HSDPa:MIMO:
CVPB<di> <Cvpb>
```

The command switches the order of the constellation points of the 16QAM and 64QAM mapping.

The re-arrangement is done according to 3GPP TS25.212.



**Parameters:**

<Cvpb> 0 | 1 | 2 | 3  
 Range: 0 to 3  
 \*RST: 0

**Example:**

BB:W3GP:BST1:CHAN12:HSDP:MIMO:CVPB2 1  
 selects interchange of MSBs with LSBs for stream 2.

**Manual operation:**

See "[Constellation Version Parameter b Stream 1/2 - BS](#)" on page 92

**[:SOURCE<hw>]:BB:W3GPp:BSTation<st>:CHANnel<ch0>:HSDPa:MIMO:  
 MODulation<di> <Modulation>**

Sets the modulation for stream 1 and stream 2 to QPSK, 16QAM or 64QAM.

**Parameters:**

<Modulation> QPSK | QAM16 | QAM64  
 \*RST: HSQP

**Example:**

BB:W3GP:BST1:CHAN12:HSDP:MIMO:MOD1 HS64Q

**Options:**

64QAM requires R&S SMBVB-K83

**Manual operation:**

See "[Modulation Stream 1/2 \(HS-PDSCH MIMO\)](#)" on page 91

**[:SOURCE<hw>]:BB:W3GPp:BSTation<st>:CHANnel<ch0>:HSDPa:MIMO:  
 PWPattern <PwPattern>**

Sets the precoding weight parameter w2 for MIMO precoding.

The values of the weight parameters w1, w3 and w4 are calculated based on the value for w2 (see [Chapter 2.3.14, "MIMO in HSPA+"](#), on page 30).

**Parameters:**

<PwPattern> string  
 \*RST: 0

**Example:**

BB:W3GP:BST1:CHAN12:HSDP:MIMO:PWP "0,1,3"  
 selects the pattern.

**Manual operation:**

See "[Precoding Weight Pattern \(w2\)](#)" on page 91

**[:SOURCE<hw>]:BB:W3GPp:BSTation<st>:CHANnel<ch0>:HSDPa:MIMO:  
 STAPattern <StaPattern>**

Enables/disables a temporal deactivation of Stream 2 per TTI in form of sending pattern.

The stream 2 sending pattern is a sequence of max 16 values of "1" (enables Stream 2 for that TTI) and "-" (disabled Stream 2 for that TTI).

**Parameters:**

<StaPattern> string  
 \*RST: 1

**Example:**

BB:W3GP:BST1:CHAN12:HSDP:MIMO:STAP "11-"  
 selects the pattern.

**Manual operation:** See "[Stream 2 Active Pattern](#)" on page 91

**[[:SOURCE<hw>]:BB:W3GPp:BSTation<st>:CHANnel<ch0>:HSDPa:MODE <Mode>**

The command selects the HSDPA mode.

**Parameters:**

<Mode> CONTInuous | PSF0 | PSF1 | PSF2 | PSF3 | PSF4 | HSET

**CONTInuous**

The high speed channel is generated continuously. This mode is defined in test model 5.

**PSFx**

The high speed channel is generated in packet mode. The start of the channel is set by selecting the subframe in which the first packet is sent.

**HSET**

The high speed channels are preset according to TS 25.1401 Annex A.7, H-Set.

\*RST: CONTInuous

**Example:**

BB:W3GP:BST1:CHAN12:HSDP:MODE PSF1  
 selects packet mode for channel 12. The first packet is sent in packet subframe 1 (PSF1).

**Manual operation:** See "[HSDPA Mode](#)" on page 89

**[[:SOURCE<hw>]:BB:W3GPp:BSTation<st>:CHANnel<ch0>:HSDPa:TTIDistance <TtiDistance>**

The command selects the distance between two packets in HSDPA packet mode. The distance is set in number of sub-frames (3 slots = 2 ms). An "Inter TTI Distance" of 1 means continuous generation.

**Parameters:**

<TtiDistance> integer  
 Range: 1 to 16  
 \*RST: 5

**Example:**

BB:W3GP:BST1:CHAN12:HSDP:TTID 2  
 selects an Inter TTI Distance of 2 subframes.

**Manual operation:** See "[Inter TTI Distance \(H-Set\)](#)" on page 90

---

```
[:SOURce<hw>]:BB:W3GPp:BSTation<st>:CHANnel<ch0>:POWer <Power>
```

Sets the channel power relative to the powers of the other channels. This setting also determines the starting power of the channel for Misuse TPC, Dynamic Power Control and the power control sequence simulation of OCNS mode 3i channels.

With the command `SOURce:BB:W3GPp:POWer:ADJust`, the power of all the activated channels is adapted so that the total power corresponds to 0 dB. This does not change the power ratio among the individual channels.

**Parameters:**

```
<Power>          float
                  Range:    -80 to 0
                  Increment: 0.01
                  *RST:     depends on channel
```

**Example:**

```
BB:W3GP:BST2:CHAN12:POW -10dB
```

Sets the channel power of channel 12 of base station 2 dB to -10 dB relative to the power of the other channels.

**Manual operation:** See "[Power](#)" on page 75

---

```
[:SOURce<hw>]:BB:W3GPp:BSTation<st>:CHANnel<ch0>:SFORmat <SFormat>
```

The command sets the slot format of the selected channel. The value range depends on the selected channel.

The slot format determines the symbol rate (and thus the range of values for the channelization code), the TFCI state and the pilot length. If the value of any one of the four parameters is changed, all the other parameters are adapted as necessary.

In the case of enhanced channels with active channel coding, the selected channel coding also affects the slot format and thus the remaining parameters. If these parameters are changed, the channel coding type is set to user.

**Parameters:**

```
<SFormat>        integer
                  Range:    0 to dynamic
                  *RST:     0
```

**Example:**

```
BB:W3GP:BST2:CHAN12:SFOR 8
```

Selects slot format 8 for channel 12 of base station 2.

**Manual operation:** See "[Slot Format](#)" on page 75

---

```
[:SOURce<hw>]:BB:W3GPp:BSTation<st>:CHANnel<ch0>:SRATe <SRate>
```

The command sets the symbol rate of the selected channel. The value range depends on the selected channel and the selected slot format.

The slot format determines the symbol rate (and thus the range of values for the channelization code), the TFCI state and the pilot length. If the value of any one of the four parameters is changed, all the other parameters are adapted as necessary.

In the case of enhanced channels with active channel coding, the selected channel coding also affects the slot format and thus the remaining parameters. If these parameters are changed, the channel coding type is set to user.

**Parameters:**

<SRate> D7K5 | D15K | D30K | D60K | D120k | D240k | D480k | D960k  
 \*RST: DPCHs D30K; CHAN1..10 D15K; DL-DPCCH (CHAN11) D7K5;

**Example:**

BB:W3GP:BST2:CHAN12:SRAT D120K  
 Sets the symbol rate for channel 12 of base station 2 to 120 ksps.

**Manual operation:** See ["Symbol Rate"](#) on page 75

**[:SOURce<hw>]:BB:W3GPp:BSTation<st>:CHANnel<ch0>:STATe <State>**

The command activates the selected channel.

**Parameters:**

<State> ON | OFF  
 \*RST: 0

**Example:**

BB:W3GP:BST2:CHAN12:STAT OFF  
 deactivates channel 12 of base station 2.

**Manual operation:** See ["Channel State"](#) on page 77

**[:SOURce<hw>]:BB:W3GPp:BSTation<st>:CHANnel<ch0>:TOFFset <TOffset>**

Sets the timing offset.

**Parameters:**

<TOffset> integer  
 For F-DPCH channels, the value range is 0 to 9.  
 \*RST: 0

**Example:**

BB:W3GP:BST2:CHAN12:TOFF 20  
 defines a frame shift relative to the scrambling code sequence of 20\*256 chips.

**Manual operation:** See ["Timing Offset"](#) on page 76

**[:SOURce<hw>]:BB:W3GPp:BSTation<st>:CHANnel<ch0>:TYPE <Type>**

Sets the channel type.

**Parameters:**

&lt;Type&gt;

PCPich | SCPich | PSCH | SSCH | PCCPch | SCCPch | PICH |  
 APAich | AICH | PDSCch | DPCCh | DPCH | HSSCch | HSQPsk |  
 HSQam | HS64Qam | HSMimo | EAGCh | ERGCh | EHICH |  
 FDPCh | HS16Qam

The channels types of CHANnel10 to CHANnel18 are predefined.  
 For the remaining channels, you can select a channel type from  
 the relevant standard channels and the high-speed channels

**Example:**

```
SOURce1:BB:W3GPP:BSTation1:CHANnel12:TYPE
HSQPsk
selects channel type HS-PDS, QPSK for channel 12
```

**Manual operation:** See "[Channel Type](#)" on page 74

```
[:SOURce<hw>]:BB:W3GPP:BSTation<st>:CHANnel<ch0>[:HSUPa]:EAGCh:
IFCoding <IfCoding>
```

Enables/disables the information coding.

**Parameters:**

&lt;IfCoding&gt;

1 | ON | 0 | OFF

**0|OFF**

corresponds to a standard operation; no coding is performed  
 and the data is sent uncoded.

**1|ON**

you can configure the way the data is coded

\*RST: 0

**Example:**

```
SOURce1:BB:W3GPP:BSTation1:CHANnel9:HSUPa:
EAGCh:IFCoding 1
SOURce1:BB:W3GPP:BSTation1:CHANnel9:HSUPa:
EAGCh:TTIEdch 2
SOURce1:BB:W3GPP:BSTation1:CHANnel9:HSUPa:
EAGCh:TTICount 2
SOURce1:BB:W3GPP:BSTation1:CHANnel9:HSUPa:
EAGCh:TTI0:UEID 100
SOURce1:BB:W3GPP:BSTation1:CHANnel9:HSUPa:
EAGCh:TTI0:AGVIndex 20
SOURce1:BB:W3GPP:BSTation1:CHANnel9:HSUPa:
EAGCh:TTI0:AGSCope PER
SOURce1:BB:W3GPP:BSTation1:CHANnel9:HSUPa:
EAGCh:TTI1:UEID 10000
SOURce1:BB:W3GPP:BSTation1:CHANnel9:HSUPa:
EAGCh:TTI1:AGVIndex 1
SOURce1:BB:W3GPP:BSTation1:CHANnel9:HSUPa:
EAGCh:TTI1:AGSCope ALL
```

**Manual operation:** See "[E-AGCH Information Field Coding](#)" on page 139

---

**[ :SOURce<hw>]:BB:W3GPp:BSTation<st>:CHANnel<ch0>[:HSUPa]:EAGCh:  
TTI<di0>:AGScope <AGScope>**

Sets the scope of the selected grant. According to the TS 25.321, the impact of each grant on the UE depends on this parameter.

For E-DCH TTI = 10ms, the absolute grant scope is always ALL (All HARQ Processes).

**Parameters:**

<AGScope>            ALL | PER

**Example:**

see [ :SOURce<hw>]:BB:W3GPp:BSTation<st>:  
CHANnel<ch0>[:HSUPa]:EAGCh:IFCoding on page 317

**Manual operation:** See "Absolute Grant Scope" on page 139

---

**[ :SOURce<hw>]:BB:W3GPp:BSTation<st>:CHANnel<ch0>[:HSUPa]:EAGCh:  
TTI<di0>:AGVIndex <AgvIndex>**

Sets the Index for the selected TTI. According to the TS 25.212 (4.10.1A.1), there is a cross-reference between the grant's index and the grant value.

**Parameters:**

<AgvIndex>            integer  
Range:            0 to 31

**Example:**

see [ :SOURce<hw>]:BB:W3GPp:BSTation<st>:  
CHANnel<ch0>[:HSUPa]:EAGCh:IFCoding on page 317

**Manual operation:** See "Absolute Grant Value Index" on page 139

---

**[ :SOURce<hw>]:BB:W3GPp:BSTation<st>:CHANnel<ch0>[:HSUPa]:EAGCh:  
TTI<di0>:UEID <Ueid>**

Sets the UE Id for the selected TTI.

**Parameters:**

<Ueid>                integer  
Range:            0 to 65535

**Example:**

see [ :SOURce<hw>]:BB:W3GPp:BSTation<st>:  
CHANnel<ch0>[:HSUPa]:EAGCh:IFCoding on page 317

**Manual operation:** See "UEID (A-GCH)" on page 139

---

**[ :SOURce<hw>]:BB:W3GPp:BSTation<st>:CHANnel<ch0>[:HSUPa]:EAGCh:  
TTICount <TtiCount>**

Sets the number of configurable TTIs.

**Parameters:**

<TtiCount> integer  
Range: 1 to 10

**Example:**

```
SOURce1:BB:W3Gpp:BSTation1:CHANnel9:TYPE EAGCh
SOURce1:BB:W3Gpp:BSTation1:CHANnel9:HSUPa:
EAGCh:TTICount 5
```

**Manual operation:** See ["Number of Configurable TTIs"](#) on page 139

**[:SOURce<hw>]:BB:W3Gpp:BSTation<st>:CHANnel<ch0>[:HSUPa]:EAGCh:  
TTIEdch <Ttiedch>**

Sets the processing duration.

**Parameters:**

<Ttiedch> 2ms | 10ms  
\*RST: 2ms

**Example:**

see [\[:SOURce<hw>\]:BB:W3Gpp:BSTation<st>:  
CHANnel<ch0>\[:HSUPa\]:EAGCh:IFCoding](#) on page 317

**Manual operation:** See ["E-DCH TTI"](#) on page 139

**[:SOURce<hw>]:BB:W3Gpp:BSTation<st>:CHANnel<ch0>[:HSUPa]:EHICH:  
CTYPE <CType>**

Sets the cell type.

**Parameters:**

<CType> SERVing | NOSERVing  
\*RST: SERVing

**Example:**

```
SOURce1:BB:W3Gpp:BSTation1:CHANnel9:TYPE EHICH
SOURce1:BB:W3Gpp:BSTation1:CHANnel9:HSUPa:
EHICH:CTYPE SERVing
SOURce1:BB:W3Gpp:BSTation1:CHANnel9:HSUPa:
EHICH:TTIEdch 2ms
SOURce1:BB:W3Gpp:BSTation1:CHANnel9:HSUPa:
EHICH:SSINDEX 2
SOURce1:BB:W3Gpp:BSTation1:CHANnel9:HSUPa:
EHICH:DTAU 2
SOURce1:BB:W3Gpp:BSTation1:CHANnel9:HSUPa:
EHICH:ETAU?
Response: 5
SOURce1:BB:W3Gpp:BSTation1:CHANnel9:HSUPa:
EHICH:RGPattern "+-+-"
SOURce1:BB:W3Gpp:BSTation1:CHANnel9:HSUPa:
EHICH:CTYPE NOSERVing
SOURce1:BB:W3Gpp:BSTation1:CHANnel9:HSUPa:
EHICH:RGPattern "+0+0"
```

**Manual operation:** See ["Type of Cell"](#) on page 140

---

```
[ :SOURce<hw>]:BB:W3GPp:BSTation<st>:CHANnel<ch0>[:HSUPa]:EHICH:DTAU
<Dtau>
```

Sets the offset of the downlink dedicated offset channels.

**Suffix:**

<ch0> 9..138

**Parameters:**

<Dtau> integer  
 Range: 0 to 149  
 \*RST: 0

**Example:** see [\[:SOURce<hw>\]:BB:W3GPp:BSTation<st>:CHANnel<ch0>\[:HSUPa\]:EHICH:CTYPe](#) on page 319

**Manual operation:** See ["Tau DPCH"](#) on page 141

---

```
[ :SOURce<hw>]:BB:W3GPp:BSTation<st>:CHANnel<ch0>[:HSUPa]:EHICH:
ETAU?
```

Queries the offset of the P-CCPCH frame boundary.

**Return values:**

<Etau> integer  
 Range: 0 to 149

**Example:** see [\[:SOURce<hw>\]:BB:W3GPp:BSTation<st>:CHANnel<ch0>\[:HSUPa\]:EHICH:CTYPe](#) on page 319

**Usage:** Query only

**Manual operation:** See ["Tau E-RGCH/E-HICH"](#) on page 141

---

```
[ :SOURce<hw>]:BB:W3GPp:BSTation<st>:CHANnel<ch0>[:HSUPa]:EHICH:
RGPAtern <RgPattern>
```

Sets the bit pattern for the ACK/NACK field.

**Parameters:**

<RgPattern> <32-bit long pattern>  
**"+" (ACK) and "0" (no signal)**  
 For the non serving cell  
**"+" (ACK) and "-" (NACK)**  
 For the serving cell  
 \*RST: +

**Example:** see [\[:SOURce<hw>\]:BB:W3GPp:BSTation<st>:CHANnel<ch0>\[:HSUPa\]:EHICH:CTYPe](#) on page 319



**Manual operation:** See ["ACK/NACK Pattern"](#) on page 141

---

**[:SOURCE<hw>]:BB:W3GPp:BSTation<st>:CHANnel<ch0>[:HSUPa]:EHICH:  
SSINDEX <SsIndex>**

Sets the value that identifies the user equipment. The values are defined in TS 25.211.

**Suffix:**

<ch0> 9..138

**Parameters:**

<SsIndex> integer  
Range: 0 to 39  
\*RST: 0

**Example:** see [\[:SOURCE<hw>\]:BB:W3GPp:BSTation<st>:  
CHANnel<ch0>\[:HSUPa\]:EHICH:CTYPE](#) on page 319

**Manual operation:** See ["Signature Hopping Pattern Index – HSUPA BS"](#)  
on page 141

---

**[:SOURCE<hw>]:BB:W3GPp:BSTation<st>:CHANnel<ch0>[:HSUPa]:EHICH:  
TTIEDch <Ttiedch>**

Sets the processing duration.

**Parameters:**

<Ttiedch> 2ms | 10ms  
\*RST: 2ms

**Example:** see [\[:SOURCE<hw>\]:BB:W3GPp:BSTation<st>:  
CHANnel<ch0>\[:HSUPa\]:EHICH:CTYPE](#) on page 319

**Manual operation:** See ["E-DCH TTI"](#) on page 140

---

**[:SOURCE<hw>]:BB:W3GPp:BSTation<st>:CHANnel<ch0>[:HSUPa]:ERGCh:  
CTYPE <CType>**

Selects the cell type.

**Parameters:**

<CType> SERVing | NOSERVing  
\*RST: SERVing

**Example:** SOUR:BB:W3GP:BST1:CHAN9:HSUP:ERGC:CTYP SERV

**Manual operation:** See ["Type of Cell"](#) on page 140

---

**[:SOURCE<hw>]:BB:W3GPp:BSTation<st>:CHANnel<ch0>[:HSUPa]:ERGCh:  
DTAU <Dtau>**

Sets the offset of the downlink dedicated offset channels.

**Parameters:**

<Dtau> integer  
 Range: 0 to 149  
 \*RST: 0

**Example:** SOUR:BB:W3GP:BST1:CHAN12:HSUP:ERGC:DTAU 5

**Manual operation:** See "[Tau DPCH](#)" on page 141

**[:SOURce<hw>]:BB:W3GPp:BSTation<st>:CHANnel<ch0>[:HSUPa]:ERGCh:ETAU?**

Queries the offset of the P-CCPCH frame boundary.

**Return values:**

<Etau> integer  
 Range: 0 to 149

**Example:** SOUR:BB:W3GP:BST1:CHAN12:HSUP:ERGC:ETAU?

**Usage:** Query only

**Manual operation:** See "[Tau E-RGCH/E-HICH](#)" on page 141

**[:SOURce<hw>]:BB:W3GPp:BSTation<st>:CHANnel<ch0>[:HSUPa]:ERGCh:RGPattern <RgPattern>**

Sets the bit pattern for the relative grant pattern field.

**Parameters:**

<RgPattern> string

**Example:** SOUR:BB:W3GP:BST1:CHAN10:HSUP:ERGC:RGPA "-"  
 Sets the bit pattern to "-" (down).

**Manual operation:** See "[Relative Grant Pattern](#)" on page 141

**[:SOURce<hw>]:BB:W3GPp:BSTation<st>:CHANnel<ch0>[:HSUPa]:ERGCh:SSIndex <SsIndex>**

Sets the value that identifies the user equipment. The values are defined in TS 25.211.

**Parameters:**

<SsIndex> integer  
 Range: 0 to 39  
 \*RST: 0

**Example:** SOUR:BB:W3GP:BST1:CHAN9:HSUP:ERGC:SSIN 0  
 Sets the value to identify the user equipment.

**Manual operation:** See "[Signature Hopping Pattern Index – HSUPA BS](#)" on page 141

---

```
[ :SOURce<hw>]:BB:W3GPp:BSTation<st>:CHANnel<ch0>[:HSUPa]:ERGCh:
TTIEdch <Ttiedch>
```

Sets processing duration.

**Parameters:**

```
<Ttiedch>          2ms | 10ms
*RST:              2ms
```

**Example:** SOUR:BB:W3GP:BST1:CHAN10:HSUP:ERGC:TTIE 2ms

**Manual operation:** See "E-DCH TTI" on page 140

---

```
[ :SOURce<hw>]:BB:W3GPp:BSTation<st>:CMODE:DLFStructure <DlfStructure>
```

The command selects the frame structure. The frame structure determines the transmission of TPC and pilot field in the transmission gaps.

**Parameters:**

```
<DlfStructure>    A | B

A
Type A, the pilot field is sent in the last slot of each transmission
gap.

B
Type B, the pilot field is sent in the last slot of each transmission
gap. The first TPC field of the transmission gap is sent in addition.

*RST:              A
```

**Example:** BB:W3GP:BST2:CMOD:DLFS A  
selects frame structure of type A.

**Manual operation:** See "DL Frame Structure - BS" on page 84

---

```
[ :SOURce<hw>]:BB:W3GPp:BSTation<st>:CMODE:METHod <Method>
```

The command selects compressed mode method.

**Parameters:**

```
<Method>          PUNcturing | HLSCheduling | SF2
```

**PUNcturing**

The data is compressed by reducing error protection.

**HLSCheduling**

The data is compressed by stopping the transmission of the data stream during the transmission gap.

**SF2**

The data is compressed by halving the spreading factor.

```
*RST:              SF2
```

**Example:** BB:W3GP:BST2:CMOD:METH HLSC  
selects compressed mode method High Layer Scheduling.

**Manual operation:** See "[Compressed Mode Method - BS](#)" on page 84

---

**[:SOURce<hw>]:BB:W3GPp:BSTation<st>:CMODE:PATtern<ch>:TGD <Tgd>**

Sets the transmission gap distances.

**Parameters:**

<Tgd> integer  
 Range: 3 to 100  
 \*RST: 15

**Example:** BB:W3GP:BST2:CMOD:PATT2:TGD 7  
 sets transmission gap distance of pattern 2 to 7 slots.

**Manual operation:** See "[Distance](#)" on page 86

---

**[:SOURce<hw>]:BB:W3GPp:BSTation<st>:CMODE:PATtern<ch>:TGL<di> <Tgl>**

Sets the transmission gap lengths.

**Parameters:**

<Tgl> integer  
 Range: 3 to 14  
 \*RST: 3

**Example:** BB:W3GP:BST2:CMOD:PATT2:TGL1 4  
 sets transmission gap length of gap 1 of pattern 2 to 4 slots.

**Manual operation:** See "[Gap Len:](#)" on page 86

---

**[:SOURce<hw>]:BB:W3GPp:BSTation<st>:CMODE:PATtern<ch>:TGPL <Tgpl>**

The command sets the transmission gap pattern lengths. Setting 0 is available only for pattern 2.

The transmission gap pattern length of the user equipment with the same suffix as the selected base station is set to the same value.

**Parameters:**

<Tgpl> integer  
 Range: 0 to 100  
 \*RST: 2

**Example:** BB:W3GP:BST2:CMOD:PATT2:TGPL 7  
 sets transmission gap pattern length of pattern 2 to 7 frames.

**Manual operation:** See "[Pattern Len:](#)" on page 87

---

**[:SOURce<hw>]:BB:W3GPp:BSTation<st>:CMODE:PATtern<ch>:TGSN <Tgsn>**

Sets the transmission gap slot number of pattern 1.

**Parameters:**

<Tgsn> integer  
 Range: 0 to 14  
 \*RST: 7

**Example:**

BB:W3GP:BST2:CMOD:PATT:TGSN 4  
 sets slot number of pattern 1 to slot 4.

**Manual operation:** See "[At Slot](#):" on page 86

**[ :SOURCE<hw>]:BB:W3GPp:BSTation<st>|MSTation<st>:CMODE:POFFset**  
 <POffset>

The command sets the power offset for mode USER.

**Parameters:**

<POffset> float  
 Range: 0 dB to 10 dB  
 Increment: 0.01 dB  
 \*RST: 0 dB

**Example:**

BB:W3GP:BST2|UE2:CMOD:POFF 4  
 sets the power offset value to 4 dB.  
 BB:W3GP:BST2|UE2:CMOD:POM USER  
 selects power offset mode USER

**Manual operation:** See "[Power Offset](#)" on page 85

**[ :SOURCE<hw>]:BB:W3GPp:BSTation<st>|MSTation<st>:CMODE:POMode**  
 <PoMode>

The command selects the power offset mode.

**Parameters:**

<PoMode> AUTO | USER

**AUTO**

The power offset is obtained by pilot bit ratio as follows:  
 Number of pilots bits of non-compressed slots / Number of pilot bits by compressed slots.

**USER**

The power offset is defined by command `[ :SOURCE<hw>]:BB:W3GPp:BSTation<st>|MSTation<st>:CMODE:POFFset`.

\*RST: AUTO

**Example:**

BB:W3GP:BST2|UE2:CMOD:POFF 4  
 sets the power offset value to 4 dB.  
 BB:W3GP:BST2|UE2:CMOD:POM USER  
 selects power offset mode USER.

**Manual operation:** See "[Power Offset Mode](#)" on page 85

---

**[ :SOURce<hw>]:BB:W3GPp:BSTation<st>:CMODE:STATe <State>**

The command activates/deactivates the compressed mode.

**Parameters:**

<State>                    ON | OFF  
 \*RST:                    0

**Example:**                    BB:W3GP:BST2:CMOD:STAT ON  
 activates compressed mode for base station 2.

**Manual operation:**    See "[Compressed Mode State](#)" on page 83

---

**[ :SOURce<hw>]:BB:W3GPp:BSTation<st>:DCONflict:RESolve**

The command resolves existing domain conflicts by modifying the Channelization Codes of the affected channels.

**Example:**                    BB:W3GP:BST2:DCON:STAT?  
 queries whether a code domain conflict exists for base station 2.  
 Response: 1  
 there is a conflict.  
 BB:W3GP:BST2:DCON:RES  
 resolves the code domain error by modifying the Channelization codes of the affected channels.

**Usage:**                    Event

**Manual operation:**    See "[Domain Conflict, Resolving Domain Conflicts](#)" on page 78

---

**[ :SOURce<hw>]:BB:W3GPp:BSTation<st>:DCONflict[:STATe]?**

The command queries whether there is (response 1) or is not (response 0) a conflict (overlap) in the hierarchically-structured channelization codes. The cause of a possible domain conflict can be ascertained by manual operation in the "BS > Code Domain" dialog.

**Return values:**

<State>                    1 | ON | 0 | OFF  
 \*RST:                    0

**Example:**                    BB:W3GP:BST2:DCON:STAT?  
 queries whether a code domain conflict exists for base station 2.  
 Response: 0  
 there is no conflict.

**Usage:**                    Query only

**Manual operation:**    See "[Domain Conflict, Resolving Domain Conflicts](#)" on page 78

---

**[ :SOURce<hw>]:BB:W3GPp:BSTation<st>:OLTDiversity <OltDiversity>**

Activates/deactivates open loop transmit diversity.

The antenna whose signal is to be simulated is selected with the command `[ :SOURce<hw>]:BB:W3GPp:BSTation<st>:TDIVersity`.

**Parameters:**

<OltDiversity> ON | OFF  
\*RST: OFF

**Example:**

`BB:W3GP:BST2:TDIV ANT2`  
calculates and applies the output signal for antenna 2 of one two-antenna system.  
`BB:W3GP:BST2:OLTD ON`  
enables open loop transmit diversity.

**Manual operation:** See "[Open Loop Transmit Diversity](#)" on page 70

`[ :SOURce<hw>]:BB:W3GPp:BSTation<st>:PINDicator:COUNT <Count>`

The command sets the number of page indicators (PI) per frame in the page indicator channel (PICH).

**Parameters:**

<Count> D18 | D36 | D72 | D144  
\*RST: D18

**Example:**

`BB:W3GP:BST2:PIND:COUN D36`  
sets the number of page indicators (PI) per frame in the page indicator channel (PICH) to 36.

**Manual operation:** See "[Page Indicators/Frame](#)" on page 70

`[ :SOURce<hw>]:BB:W3GPp:BSTation<st>:SCODE <SCode>`

Sets the identification for the base station. This value is simultaneously the initial value of the scrambling code generator.

**Parameters:**

<SCode> integer  
Range: #H0 to #H5FFF  
\*RST: #H0

**Example:**

`BB:W3GP:BST2:SCOD #H1FFF`  
sets the scrambling code

**Manual operation:** See "[Scrambling Code \(hex\)](#)" on page 69

`[ :SOURce<hw>]:BB:W3GPp:BSTation<st>:SCODE:STATE <State>`

The command makes it possible to deactivate base station scrambling for test purposes.

**Parameters:**

<State> ON | OFF  
 \*RST: ON

**Example:**

BB:W3GP:BST2:SCOD:STAT OFF  
 deactivates scrambling for base station 2.

**Manual operation:** See "[Scrambling Code On](#)" on page 69

**[:SOURce<hw>]:BB:W3GPp:BSTation<st>:SCPich:PREFere[nce][:STATE] <State>**

The command activates or deactivates the use of S-CPICH as reference phase.

**Parameters:**

<State> ON | OFF  
 \*RST: 0

**Example:**

BB:W3GP:BST2:SCP:REF ON  
 activates the use of S-CPICH as reference phase for base station 2.

**Manual operation:** See "[S-CPICH As Phase Reference](#)" on page 70

**[:SOURce<hw>]:BB:W3GPp:BSTation<st>:SSCG?**

The command queries the secondary synchronization code group. This parameter is specified in the table defined by the 3GPP standard "Allocation of SSCs for secondary SCH". This table assigns a specific spreading code to the synchronization code symbol for every slot in the frame. The value is calculated from the scrambling code.

**Return values:**

<Scsg> integer  
 Range: 0 to 63

**Example:**

BB:W3GP:BST2:SSCG?  
 queries the 2nd search code group for base station 2.  
 Response: 24  
 the base station is part of second search group 24.

**Usage:** Query only

**Manual operation:** See "[2<sup>nd</sup> Search Code Group](#)" on page 69

**[:SOURce<hw>]:BB:W3GPp:BSTation<st>:STATE <State>**

Activates and deactivates the specified base station.

**Parameters:**

<State> 1 | ON | 0 | OFF  
 \*RST: 1 (BSTation1), 0 (all other)

**Example:**

BB:W3GP:BST2:STAT OFF  
 deactivates base station 2.



**Manual operation:** See ["Select Basestation/User Equipment"](#) on page 59  
See ["State"](#) on page 69

---

**[:SOURce<hw>]:BB:W3GPp:BSTation<st>:TDElay <Tdelay>**

Adds a time shift for the selected base station compared to base station 1.

**Parameters:**

<Tdelay> integer  
Range: 0 to 38400  
\*RST: 0  
Default unit: chip

**Example:** BB:W3GP:BST2:TDEL 256  
shifts base station 2 by 256 chips compared to base station 1.

**Manual operation:** See ["Time Delay"](#) on page 70

---

**[:SOURce<hw>]:BB:W3GPp:BSTation<st>:TDiversity <TDiversity>**

Selects the antenna and the antenna configuration to be simulated.

To simulate transmit diversity, a two-antenna system has to be selected and Open Loop Transmit Diversity has to be activated (command BB:W3GP:BST:OLTD ON).

**Parameters:**

<TDiversity> SANT | ANT1 | ANT2 | OFF  
SANT = single-antenna system  
\*RST: SANT

**Example:** BB:W3GP:BST2:TDIV ANT2  
the signal of antenna 2 of one two-antenna system is simulated.

**Manual operation:** See ["Diversity / MIMO"](#) on page 70  
See ["Open Loop Transmit Diversity"](#) on page 70

## 5.8 Enhanced channels of base station 1

The SOURce:BB:W3GPp:BSTation:ENHanced subsystem contains the commands for setting the enhanced channels of base station 1. The commands of this system only take effect when the 3GPP FDD standard is activated, the downlink transmission direction is selected, base station 1 is enabled and enhanced channels are activated:

SOURce:BB:W3GPp:STATe ON

SOURce:BB:W3GPp:LINK DOWN

SOURce:BB:W3GPp:BST1:STATe ON

SOURce:BB:W3GPp:BST:ENHanced:CHANnel<11...13>:DPCH:STATe ON

Or

SOURce:BB:W3GPp:BST:ENHanced:PCCPch:STATe ON

**BS**Tation<st>

The numeric suffix to **BS**Tation determines the base station. Enhanced channels are enabled for base station 1 only.

**CHAN**nel<ch0>

The value range is **CHAN**nel<11|12|13> for enhanced DPCHs and **CHAN**nel<4> for P-CCPCH.

**TCH**annel<di>

The transport channel designations for remote control are **TCH**annel0 for DCCH, **TCH**annel1 to **TCH**annel6 for DTCH1 to DTCH6.

### 5.8.1 General settings

[SOURce<hw>]:BB:W3GPp:BSTation:ENHanced:CHANnel<ch0>:DPCH:STATe..... 330  
 [SOURce<hw>]:BB:W3GPp:BSTation:ENHanced:PCCPch:STATe..... 330  
 [SOURce<hw>]:BB:W3GPp:BSTation<st>:ENHanced:PCPich:PATtern..... 330

---

[SOURce<hw>]:BB:W3GPp:BSTation:ENHanced:CHANnel<ch0>:DPCH:STATe  
 <State>

The command switches the selected channel to the enhanced state.

**Parameters:**

<State> ON | OFF  
 \*RST: 0

**Example:** BB:W3GP:BST:ENH:CHAN13:DPCH:STAT ON  
 switches DPCH 13 to Enhanced State.

**Manual operation:** See "Enhanced State" on page 114

---

[SOURce<hw>]:BB:W3GPp:BSTation:ENHanced:PCCPch:STATe <State>

The command activates or deactivates the enhanced state of the P-CCPCH (BCH).

**Parameters:**

<State> ON | OFF  
 \*RST: OFF

**Example:** BB:W3GP:BST:ENH:PCCP:STAT ON  
 switches the P-CCPCH to Enhanced State.

**Manual operation:** See "State (Enhanced P-CCPCH)" on page 111

---

[SOURce<hw>]:BB:W3GPp:BSTation<st>:ENHanced:PCPich:PATtern <Pattern>

Sets the P-CPICh pattern (channel 0).

**Parameters:**

<Pattern> ANT1 | ANT2  
 \*RST: ANT1

**Example:**

BB:W3GP:BST2:ENH:PCP:PATT ANT2  
 sets the P-CPICH Pattern to Antenna 2.

**Manual operation:** See "[P-CPICH Pattern](#)" on page 110

**5.8.2 Channel coding**

[SOURce<hw>]:BB:W3GPp:BSTation:ENHanced:CHANnel[<ch0>]:DPCH:CCODing: USER:DELeTe.....	332
[SOURce<hw>]:BB:W3GPp:BSTation:ENHanced:CHANnel<ch0>:DPCH:CCODing: BPFRame?.....	332
[SOURce<hw>]:BB:W3GPp:BSTation:ENHanced:CHANnel<ch0>:DPCH:CCODing: SFOrmat.....	333
[SOURce<hw>]:BB:W3GPp:BSTation:ENHanced:CHANnel<ch0>:DPCH:CCODing:SRATe?	333
[SOURce<hw>]:BB:W3GPp:BSTation:ENHanced:CHANnel<ch0>:DPCH:CCODing:STATe...	334
[SOURce<hw>]:BB:W3GPp:BSTation:ENHanced:CHANnel<ch0>:DPCH:CCODing:TYPE...	334
[SOURce<hw>]:BB:W3GPp:BSTation:ENHanced:CHANnel[<ch0>]:DPCH:CCODing: USER:CATalog?.....	335
[SOURce<hw>]:BB:W3GPp:BSTation:ENHanced:CHANnel<ch0>:DPCH:CCODing: USER:LOAD.....	336
[SOURce<hw>]:BB:W3GPp:BSTation:ENHanced:CHANnel<ch0>:DPCH:CCODing: USER:STORE.....	336
[SOURce<hw>]:BB:W3GPp:BSTation:ENHanced:CHANnel<ch0>:DPCH:INTerleaver2.....	337
[SOURce<hw>]:BB:W3GPp:BSTation:ENHanced:CHANnel<ch0>:DPCH: TCHannel<di0>:CRCSize.....	337
[SOURce<hw>]:BB:W3GPp:BSTation:ENHanced:CHANnel<ch0>:DPCH: TCHannel<di0>:DATA.....	338
[SOURce<hw>]:BB:W3GPp:BSTation:ENHanced:CHANnel<ch0>:DPCH: TCHannel<di0>:DATA:DSElect.....	338
[SOURce<hw>]:BB:W3GPp:BSTation:ENHanced:CHANnel<ch0>:DPCH: TCHannel<di0>:DATA:PATtern.....	339
[SOURce<hw>]:BB:W3GPp:BSTation:ENHanced:CHANnel<ch0>:DPCH: TCHannel<di0>:DTX.....	339
[SOURce<hw>]:BB:W3GPp:BSTation:ENHanced:CHANnel<ch0>:DPCH: TCHannel<di0>:EPRotection.....	340
[SOURce<hw>]:BB:W3GPp:BSTation:ENHanced:CHANnel<ch0>:DPCH: TCHannel<di0>:INTerleaver.....	340
[SOURce<hw>]:BB:W3GPp:BSTation:ENHanced:CHANnel<ch0>:DPCH: TCHannel<di0>:RMATtribute.....	340
[SOURce<hw>]:BB:W3GPp:BSTation:ENHanced:CHANnel<ch0>:DPCH: TCHannel<di0>:STATe.....	341
[SOURce<hw>]:BB:W3GPp:BSTation:ENHanced:CHANnel<ch0>:DPCH: TCHannel<di0>:TBCount.....	341
[SOURce<hw>]:BB:W3GPp:BSTation:ENHanced:CHANnel<ch0>:DPCH: TCHannel<di0>:TBSize.....	341

<code>[ :SOURce&lt;hw&gt;]:BB:W3GPp:BSTation:ENHanced:CHANnel&lt;ch0&gt;:DPCH: TCHannel&lt;di0&gt;:TTINterval.....</code>	342
<code>[ :SOURce&lt;hw&gt;]:BB:W3GPp:BSTation:ENHanced:PCCPch:CCODing:INTerleaver&lt;di&gt;.....</code>	342
<code>[ :SOURce&lt;hw&gt;]:BB:W3GPp:BSTation:ENHanced:PCCPch:CCODing:STAtE.....</code>	342
<code>[ :SOURce&lt;hw&gt;]:BB:W3GPp:BSTation:ENHanced:PCCPch:CCODing:TYPE?.....</code>	342

---

**`[ :SOURce<hw>]:BB:W3GPp:BSTation:ENHanced:CHANnel[<ch0>]:DPCH:  
CCODing:USER:DELete <Filename>`**

Deletes the specified files with stored user channel codings.

The files are stored with the fixed file extensions `*.3g_ccod_dl` in a directory of the user's choice. The directory applicable to the commands is defined with the command `MMEMory:CDIR`. To access the files in this directory, you only have to give the file name, without the path and the file extension.

**Setting parameters:**

<Filename>                    string

**Example:**                    `MMEM:CDIR '/var/user/temp/CcodDpchUser'`  
selects the directory for the user channel coding files.  
`BB:W3GP:BST:ENH:CHAN:DPCH:CCOD:USER:DEL`  
`'user_cc1'`  
deletes the specified file with user coding.

**Usage:**                      Setting only

---

**`[ :SOURce<hw>]:BB:W3GPp:BSTation:ENHanced:CHANnel<ch0>:DPCH:  
CCODing:BPFRame?`**

Queries the number of data bits in the DPDCH component of the frame at the physical layer.

**Return values:**

<BpFrame>                    integer  
Range:                        30 to 20000  
\*RST:                         510

**Example:**                    `BB:W3GP:BST:ENH:CHAN13:DPCH:CCOD:BPFR?`  
queries the number of data bits.  
Response: 1  
the number of data bits is 1.

**Usage:**                      Query only

**Manual operation:**        See "[Bits per Frame \(DPDCH\)](#)" on page 118

---

**[ :SOURce<hw>]:BB:W3GPp:BSTation:ENHanced:CHANnel<ch0>:DPCH:CCODing:SFORmat <SFormat>**

The command sets the slot format for the selected enhanced DPCH of base station 1. The slot format is fixed for channel-coded measurement channels conforming to the standard - "Reference Measurement Channel". Changing the slot format automatically activates User coding (W3GP:BST:ENH:CHAN<11...13>:DPCH:CCOD:TYPE USER). The slot format also fixes the symbol rate, bits per frame, pilot length and TFCI state parameters.

When a channel coding type conforming to the standard is selected ([ :SOURce<hw>]:BB:W3GPp:BSTation:ENHanced:CHANnel<ch0>:DPCH:CCODing:TYPE) and channel coding is activated, the slot format is ([ :SOURce<hw>]:BB:W3GPp:BSTation:ENHanced:CHANnel<ch0>:DPCH:CCODing:STATE) automatically set to the associated value.

Changing the slot format automatically activates User coding (W3GP:BST:ENH:CHAN<11...13>:DPCH:CCOD:TYPE USER).

The command sets the symbol rate (W3GP:BST:ENH:CHAN:DPCH:CCOD:SRAT), the bits per frame (W3GP:BST:ENH:CHAN:DPCH:CCOD:BPFR), the pilot length (W3GP:BST1:CHAN:DPCC:PLEN), and the TFCI state (W3GP:BST1:CHAN:DPCC:TFCI STAT) to the associated values.

**Parameters:**

<SFormat> integer  
 Range: 0 to dynamic  
 \*RST: 0

**Example:** BB:W3GP:BST:ENH:CHAN13:DPCH:CCOD:SFOR 4  
 sets slot format 4 for Enhanced DPCH13.

**Manual operation:** See "Slot Format (DPDCH)" on page 118

---

**[ :SOURce<hw>]:BB:W3GPp:BSTation:ENHanced:CHANnel<ch0>:DPCH:CCODing:SRATe?**

The command queries the symbol rate.

The symbol rate depends on the selected slot format ([ :SOURce<hw>]:BB:W3GPp:BSTation:ENHanced:CHANnel<ch0>:DPCH:CCODing:SFORmat), and if the slot format changes, this changes automatically as well.

**Return values:**

<SRate> D7K5 | D15K | D30K | D60K | D120k | D240k | D480k | D960k |  
 D1920k | D2880k | D3840k | D4800k | D5760k | D2X1920K |  
 D2X960K2X1920K  
 \*RST: D30K

**Example:** BB:W3GP:BST:ENH:CHAN13:DPCH:CCOD:SRAT?  
 queries the symbol rate.  
 Response: 'D30K'  
 the symbol rate of Enhanced DPCH 13 is 30 ksps.

**Usage:** Query only

**Manual operation:** See "[Symbol Rate \(DPDCH\)](#)" on page 118

---

**[:SOURCE<hw>]:BB:W3GPP:BSTation:ENHanced:CHANnel<ch0>:DPCH:CCODing:STATe <State>**

The command activates or deactivates channel coding for the selected enhanced DPCH.

When channel coding is activated and a channel coding type conforming to the standard is selected, (BB:W3GP:BST:ENH:CHAN:DPCH:CCOD:TYPE) the slot format, (BB:W3GP:BST:ENH:CHAN:DPCH:CCOD:SFOR) and thus the symbol rate, (BB:W3GP:BST:ENH:CHAN:DPCH:CCOD:SRAT) the bits per frame, (BB:W3GP:BST:ENH:CHAN:DPCH:CCOD:BPFR), the pilot length (BB:W3GP:BST1:CHAN:DPCC:PLEN) and the TFCI state (BB:W3GP:BST1:CHAN:DPCC:TFCI STAT) are set to the associated values.

**Parameters:**

<State> ON | OFF  
\*RST: OFF

**Example:** BB:W3GP:BST:ENH:CHAN13:DPCH:CCOD:TYPE M12K2  
selects channel coding type RMC 12.2 kbps for Enhanced DPCH 13.  
BB:W3GP:BST:ENH:CHAN13:DPCH:CCOD:STAT ON  
activates channel coding.

**Manual operation:** See "[Channel Coding State](#)" on page 116

---

**[:SOURCE<hw>]:BB:W3GPP:BSTation:ENHanced:CHANnel<ch0>:DPCH:CCODing:TYPE <Type>**

The command selects the channel coding scheme in accordance with the 3GPP specification.

The 3GPP specification defines 4 reference measurement channel coding types, which differ in the input data bit rate to be processed (12.2, 64, 144 and 384 kbps). The additional AMR CODER coding scheme generates the coding of a voice channel. The BTFD coding types with different data rates are also defined in the 3GPP specification (TS 34.121). They are used for the receiver quality test Blind Transport Format Detection.

When a channel coding type conforms to the standard and channel coding is activated, (`:BB:W3GP:BST:ENH:CHAN<n>:DPCH:CCOD:STAT`) the slot format (`:BB:W3GP:BST:ENH:CHAN<n>:DPCH:CCOD:SFOR`) and thus the symbol rate (`:BB:W3GP:BST:ENH:CHAN<n>:DPCH:CCOD:SRAT`), the bits per frame, (`:BB:W3GP:BST:ENH:CHAN<n>:DPCH:CCOD:BPFR`), the pilot length (`:BB:W3GP:BST1:CHAN<n>:DPCC:PLEN`) and the TFCI state (`:BB:W3GP:BST1:CHAN<n>:DPCC:TFCI:STAT`) are set to the associated values.

**Parameters:**

&lt;Type&gt;

M12K2 | M64K | M144k | M384k | AMR | BTFD1 | BTFD2 | BTFD3

**M12K2**

Measurement channel with an input data bit rate of 12.2 ksps.

**M64K**

Measurement channel with an input data bit rate of 64 ksps.

**M144k**

Measurement channel with an input data bit rate of 144 ksps.

**M384k**

Measurement channel with an input data bit rate of 384 ksps.

**AMR**

Channel coding for the AMR Coder (coding a voice channel).

**USER**

This parameter cannot be set. USER is returned whenever a user-defined channel coding is active, that is to say, after a channel coding parameter has been changed or a user coding file has been loaded. The file is loaded by the command `[ :SOURCE<hw> ] :BB:W3GPp:BSTation:ENHanced:CHANnel<ch0>:DPCH:CCODing:USER:LOAD`.

**BTFD1**

Blind Transport Format Detection Rate 1 (12.2 kbps).

**BTFD2**

Blind Transport Format Detection Rate 2 (7.95 kbps).

**BTFD3**

Blind Transport Format Detection Rate 3 (1.95 kbps).

\*RST: M12K2

**Example:**

```
BB:W3GP:BST:ENH:CHAN13:DPCH:CCOD:TYPE M144
selects channel coding scheme RMC 144 kbps.
```

**Manual operation:** See "Channel Coding Type" on page 117

---

```
[ :SOURCE<hw> ] :BB:W3GPp:BSTation:ENHanced:CHANnel[<ch0>]:DPCH:
CCODing:USER:CATalog?
```

Queries existing files with stored user channel codings.

The files are stored with the fixed file extensions \*.3g\_ccod\_d1 in a directory of the user's choice. The directory applicable to the commands is defined with the command `MMEMoRY:CDIR`.

**Return values:**

<Catalog> string

**Example:**

```
MMEM:CDIR '/var/user/temp/CcodDpchUser'
selects the directory for the user channel coding files.
BB:W3GP:BST:ENH:CHAN:DPCH:CCOD:USER:CAT?
queries the existing files with user coding.
Response: user_cc1
there is one file with user coding.
```

**Usage:** Query only

**Manual operation:** See "User Coding" on page 117

**[:SOURce<hw>]:BB:W3GPp:BSTation:ENHanced:CHANnel<ch0>:DPCH:  
CCODing:USER:LOAD <Filename>**

The command loads the specified files with stored user channel codings.

The files are stored with the fixed file extensions \*.3g\_ccod\_d1 in a directory of the user's choice. The directory applicable to the commands is defined with the command `MMEMoRY:CDIR`. To access the files in this directory, you only have to give the file name, without the path and the file extension.

**Setting parameters:**

<Filename> <user\_coding>

**Example:**

```
MMEM:CDIR '/var/user/temp/CcodDpchUser'
selects the directory for the user channel coding files.
BB:W3GP:BST:ENH:CHAN13:DPCH:CCOD:USER:LOAD
'user_cc1'
loads the specified file with user coding.
```

**Usage:** Setting only

**Manual operation:** See "User Coding" on page 117

**[:SOURce<hw>]:BB:W3GPp:BSTation:ENHanced:CHANnel<ch0>:DPCH:  
CCODing:USER:STORE <Filename>**

The command saves the current settings for channel coding as user channel coding in the specified file.

The files are stored with the fixed file extensions \*.3g\_ccod\_d1 in a directory of the user's choice. The directory in which the file is stored is defined with the command `MMEMoRY:CDIR`. To store the files in this directory, you only have to give the file name, without the path and the file extension.

**Setting parameters:**

<Filename> string



**Example:** `M MEM:CDIR '/var/user/temp/CcodDpchUser'`  
 selects the directory for the user channel coding files.  
`BB:W3GP:BST:ENH:CHAN13:DPCH:CCOD:USER:STOR`  
`'user_cc1'`  
 saves the current channel coding setting in file `user_cc1` in  
 directory `/var/user/temp/CcodDpchUser`.

**Usage:** Setting only

**Manual operation:** See ["User Coding"](#) on page 117

**[ :SOURce<hw>]:BB:W3GPp:BSTation:ENHanced:CHANnel<ch0>:DPCH:  
 INTerleaver2 <Interleaver2>**

The command activates or deactivates channel coding interleaver state 2 for the selected channel.

Interleaver state 2 is activated or deactivated for all the transport channels together. Interleaver state 1 can be activated and deactivated for each transport channel individually (command `[ :SOURce<hw>]:BB:W3GPp:BSTation:ENHanced:CHANnel<ch0>:DPCH:TCHannel<di0>:INTerleaver`).

**Note:** The interleaver states do not cause the symbol rate to change.

**Parameters:**

<Interleaver2> ON | OFF  
 \*RST: ON

**Example:** `BB:W3GP:BST:ENH:CHAN13:DPCH:INT OFF`  
 deactivates channel coding interleaver state 2 for all the TCHs of DPCH13.

**Manual operation:** See ["Interleaver 2 State"](#) on page 121

**[ :SOURce<hw>]:BB:W3GPp:BSTation:ENHanced:CHANnel<ch0>:DPCH:  
 TCHannel<di0>:CRCSize <CrcSize>**

The command defines the CRC length for the selected transport channel. It is also possible to deactivate checksum determination.

**Parameters:**

<CrcSize> NONE | 8 | 12 | 16 | 24  
 \*RST: 16

**Example:** `BB:W3GP:BST:ENH:CHAN13:DPCH:TCH0:CRCS NONE`  
 deactivates checksum determination for the DCCH of DPCH13.

**Manual operation:** See ["Size of CRC"](#) on page 120

---

```
[ :SOURce<hw>]:BB:W3GPp:BSTation:ENHanced:CHANnel<ch0>:DPCH:
TCHannel<di0>:DATA <Data>
```

The command determines the data source for the data fields of enhanced channels with channel coding. If channel coding is not active, the DPCH data source is used (:SOURce:BB:W3GPp:BST:CHANnel:DATA).

**Parameters:**

<Data> PN9 | PN11 | PN15 | PN16 | PN20 | PN21 | PN23 | DLISt | ZERO | ONE | PATTern |

**PNxx**

The pseudo-random sequence generator is used as the data source. Different random sequence lengths can be selected.

**DLISt**

A data list is used. The data list is selected with the command [:SOURce<hw>]:BB:W3GPp:BSTation:ENHanced:CHANnel<ch0>:DPCH:TCHannel<di0>:DATA:DSElect.

**ZERO | ONE**

Internal 0 and 1 data is used.

**PATTern**

Internal data is used. The bit pattern for the data is defined with the command [:SOURce<hw>]:BB:W3GPp:BSTation:ENHanced:CHANnel<ch0>:DPCH:TCHannel<di0>:DATA:PATTern.

\*RST: PN9

**Example:**

```
BB:W3GP:BST:ENH:CHAN13:DPCH:TCH1:DATA PATT
Selects the Pattern data source for the data fields of DTCH1 of
DPCH13. The bit pattern is defined with the following command.
BB:W3GP:BST:ENH:CHAN13:DPCH:TCH1:DATA:PATT
#H3F,8
Defines the bit pattern.
```

**Manual operation:** See "Data Source" on page 119

---

```
[ :SOURce<hw>]:BB:W3GPp:BSTation:ENHanced:CHANnel<ch0>:DPCH:
TCHannel<di0>:DATA:DSElect <DSelect>
```

The command selects the data list for enhanced channels for the DLISt selection.

The files are stored with the fixed file extensions \*.dm\_iqd in a directory of the user's choice. The directory applicable to the commands is defined with the command MME-Mory:CDIR. To access the files in this directory, you only have to give the file name, without the path and the file extension.

**Parameters:**

<DSelect> string

**Example:** BB:W3GP:BST:ENH:CHAN13:DPCH:TCH1:DATA DLIS  
selects the Data Lists data source for DTCH1 of DPCH13.  
MME:CDIR '/var/user/temp/IQData'  
selects the directory for the data lists.  
BB:W3GP:BST:ENH:CHAN13:DPCH:TCH1:DATA:DSEL  
'bts\_tch'  
selects the file bts\_tch as the data source.

**Manual operation:** See "[Data Source](#)" on page 119

**[[:SOURce<hw>]:BB:W3GPp:BSTation:ENHanced:CHANnel<ch0>:DPCH:  
TCHannel<di0>:DATA:PATTern <Pattern>, <BitCount>**

The command determines the bit pattern for the PATTern selection. The maximum length is 64 bits.

**Parameters:**

<Pattern> numeric  
\*RST: #H0

<BitCount> integer  
Range: 1 to 64  
\*RST: 1

**Example:** BB:W3GP:BST:ENH:CHAN13:DPCH:TCH1:DATA:PATT  
#H3F, 8  
defines the bit pattern.

**Manual operation:** See "[Data Source](#)" on page 119

**[[:SOURce<hw>]:BB:W3GPp:BSTation:ENHanced:CHANnel<ch0>:DPCH:  
TCHannel<di0>:DTX <Dtx>**

The command sets the number of DTX (Discontinuous Transmission) bits. These bits are entered in the data stream between rate matching and interleaver 1 and used for the BTFD reference measurement channels rate 2 and rate 3.

**Parameters:**

<Dtx> integer  
Range: 0 to 1024  
\*RST: 0

**Example:** BB:W3GP:BST:ENH:CHAN13:DPCH:TCH1:DTX 257  
257 bits are entered in the data stream between rate matching and interleaver 1.

**Manual operation:** See "[DTX Indication Bits](#)" on page 121

---

```
[:SOURCE<hw>]:BB:W3GPp:BSTation:ENHanced:CHANnel<ch0>:DPCH:
  TCHannel<di0>:EPRotectio n <EProtection>
```

Sets the error protection.

**Parameters:**

<EProtection> NONE | TURBo3 | CON2 | CON3

**NONE**

No error protection

**TURBo3**

Turbo Coder of rate 1/3 in accordance with the 3GPP specifications.

**CON2 | CON3**

Convolution Coder of rate 1/2 or 1/3 with generator polynomials defined by 3GPP.

\*RST: CON3

**Example:**

```
BB:W3GP:BST:ENH:CHAN13:DPCH:TCH1:EPR NONE
error protection for transport channel DTCH1 of DPCH13 is
deactivated.
```

**Manual operation:** See "[Error Protection](#)" on page 121

---

```
[:SOURCE<hw>]:BB:W3GPp:BSTation:ENHanced:CHANnel<ch0>:DPCH:
  TCHannel<di0>:INTerleaver <Interleaver>
```

The command activates or deactivates channel coding interleaver state 1 for the selected channel.

Interleaver state 1 can be activated and deactivated for each transport channel individually. The channel is selected via the suffix at TCHannel.

Interleaver state 2 can only be activated or deactivated for all the transport channels together (`[:SOURCE<hw>]:BB:W3GPp:BSTation:ENHanced:CHANnel<ch0>:DPCH:INTerleaver2`).

**Note:** The interleaver states do not cause the symbol rate to change.

**Parameters:**

<Interleaver> ON | OFF

\*RST: ON

**Manual operation:** See "[Interleaver 1 State](#)" on page 121

The transport channel designations for remote control are TCHannel0 for DCCH, TCHannel1 to TCHannel6 for DTCH1 to DTCH6.

---

```
[:SOURCE<hw>]:BB:W3GPp:BSTation:ENHanced:CHANnel<ch0>:DPCH:
  TCHannel<di0>:RMAtribute <RmAttribute>
```

Sets data rate matching.

**Parameters:**

<RmAttribute> integer  
 Range: 1 to 1024  
 \*RST: 256

**Example:**

BB:W3GP:BST:ENH:CHAN13:DPCH:TCH1:RMAT 1024  
 sets the rate matching attribute for DTCH1 of DPCH13 to 1024.

**Manual operation:** See "[Rate Matching Attribute](#)" on page 120

**[:SOURCE<hw>]:BB:W3GPp:BSTation:ENHanced:CHANnel<ch0>:DPCH:  
 TCHannel<di0>:STATe <State>**

The command activates/deactivates the selected transport channel.

**Parameters:**

<State> ON | OFF  
 \*RST: OFF

**Example:**

BB:W3GP:BST:ENH:CHAN13:DPCH:TCH1:STAT ON  
 activates DTCH1 of DPCH13.

**Manual operation:** See "[Transport Channel State](#)" on page 119

**[:SOURCE<hw>]:BB:W3GPp:BSTation:ENHanced:CHANnel<ch0>:DPCH:  
 TCHannel<di0>:TBCount <TbCount>**

Defines the number of blocks used for the selected transport channel.

**Parameters:**

<TbCount> integer  
 Range: 1 to 24  
 \*RST: 1

**Example:**

BB:W3GP:BST:ENH:CHAN13:DPCH:TCH:TBC 4  
 sets 4 transport blocks for DTCH1 of DPCH13.

**Manual operation:** See "[Transport Block](#)" on page 120

**[:SOURCE<hw>]:BB:W3GPp:BSTation:ENHanced:CHANnel<ch0>:DPCH:  
 TCHannel<di0>:TBSize <TbSize>**

Sets the size of the data blocks.

**Parameters:**

<TbSize> integer  
 Range: 0 to 4096

**Example:**

BB:W3GP:BST:ENH:CHAN13:DPCH:TCH:TBS 1024  
 sets the length of the transport blocks for DTCH1 of DPCH13 to 1024.

**Manual operation:** See "[Transport Block Size](#)" on page 120

---

**[ :SOURce<hw>]:BB:W3GPP:BSTation:ENHanced:CHANnel<ch0>:DPCH:  
TCHannel<di0>:TTINterval <TtInterval>**

Sets the number of frames into which a TCH is divided. This setting also defines the interleaver depth.

**Parameters:**

<TtInterval> 10MS | 20MS | 40MS

**Example:**

SOURce1:BB:W3GPP:BSTation:ENHanced:CHANnel13:  
DPCH:TCHannel1:TTINterval 20ms  
sets that DTCH1 of DPCH13 is divided into 2 frames.

**Manual operation:** See "[Transport Time Interval](#)" on page 120

---

**[ :SOURce<hw>]:BB:W3GPP:BSTation:ENHanced:PCCPch:CCODing:  
INTerleaver<di> <Interleaver>**

The command activates or deactivates channel coding interleaver state 1 or 2 for the P-CCPCH.

**Note:** The interleaver states do not cause the symbol rate to change.

**Parameters:**

<Interleaver> ON | OFF  
\*RST: ON

**Example:**

BB:W3GPP:BST:ENH:PCCP:CCOD:INT1 OFF  
deactivates channel coding interleaver state 1 for the P-CCPCH.

**Manual operation:** See "[Interleaver](#)" on page 113

---

**[ :SOURce<hw>]:BB:W3GPP:BSTation:ENHanced:PCCPch:CCODing:STATe  
<State>**

The command activates or deactivates channel coding for the enhanced P-CCPCH. The coding scheme of the P-CCPCH (BCH) is defined in the standard.

**Parameters:**

<State> ON | OFF  
\*RST: OFF

**Example:**

BB:W3GPP:BST:ENH:PCCP:CCOD:STAT ON  
activates channel coding for the enhanced P-CCPCH.

**Manual operation:** See "[Channel Coding State](#)" on page 113

---

**[ :SOURce<hw>]:BB:W3GPP:BSTation:ENHanced:PCCPch:CCODing:TYPE?**

The command queries the channel coding scheme in accordance with the 3GPP specification. The coding scheme of the P-CCPCH (BCH) is defined in the standard. The channel is generated automatically with the counting system frame number (SFN). The system information after the SFN field is completed from the selected data source.

**Return values:**

<Type> BCHSfn  
 \*RST: BCHSfn

**Example:**

BB:W3GP:BSTation:ENHanced:PCCP:CCOD:TYPE?  
 queries the channel coding scheme of the P-CCPCH.  
 Response: 'BCHS'  
 the channel coding scheme with SFN is used.

**Usage:**

Query only

**Manual operation:** See "Channel Coding Type" on page 113

### 5.8.3 Dynamic power control settings

#### Example: Configuring the Dynamic Power Control Settings

The following is a simple programming example with the purpose to show **all** commands for this task. In real application, some of the commands can be omitted.

```
SOURce:BB:W3GPp:BSTation:ENHanced:CHAN11:DPCH:DPControl:DIRection UP
// selects direction up, a high level of the control signals
// leads to an increase of the channel power
SOURce:BB:W3GPp:BSTation:ENHanced:CHAN11:DPCH:DPControl:STEP 1 dB
// selects a step width of 1 dB.
// A high level of the control signal leads to
// an increase of 1 dB of the channel power,
// a low level to a decrease of 1 dB.
SOURce:BB:W3GPp:BSTation:ENHanced:CHAN11:DPCH:DPControl:RANGe:DOWN 10 dB
// selects a dynamic range of 10 dB for ranging up the channel power
SOURce:BB:W3GPp:BSTation:ENHanced:CHAN11:DPCH:DPControl:RANGe:UP 50 dB
// selects a dynamic range of 50 dB for ranging up the channel power
// The overall increase and decrease of channel power,
// i.e. the dynamic range is limited to 60 dB
SOURce:BB:W3GPp:BSTation:ENHanced:CHAN11:DPCH:DPControl:MODE TPC
// selects the source of the power control signal
SOURce:BB:W3GPp:BSTation:ENHanced:CHAN11:DPCH:DPControl:STATe ON
// activates Dynamic Power Control for DPCH 11
SOURce:BB:W3GPp:BSTation:ENHanced:CHAN11:DPCH:DPControl:POWer?
// queries the deviation of the channel power of DPCH 11
```

```
[:SOURce<hw>]:BB:W3GPp:BSTation:ENHanced:CHANnel<ch0>:DPCH:DPControl:
  DIRection.....344
[:SOURce<hw>]:BB:W3GPp:BSTation:ENHanced:CHANnel<ch0>:DPCH:DPControl:MODE. 344
[:SOURce<hw>]:BB:W3GPp:BSTation<st>:ENHanced:CHANnel<ch0>:DPCH:
  DPControl:RANGe:UP.....344
[:SOURce<hw>]:BB:W3GPp:BSTation:ENHanced:CHANnel<ch0>:DPCH:DPControl:
  RANGe:DOWN.....344
[:SOURce<hw>]:BB:W3GPp:BSTation:ENHanced:CHANnel<ch0>:DPCH:DPControl:STATe. 345
```

<code>[:SOURce&lt;hw&gt;]:BB:W3GPp:BSTation:ENHanced:CHANnel&lt;ch0&gt;:DPCH:DPControl:STEP:MANual</code> .....	345
<code>[:SOURce&lt;hw&gt;]:BB:W3GPp:BSTation:ENHanced:CHANnel&lt;ch0&gt;:DPCH:DPControl:STEP[:EXTErnal]</code> .....	345
<code>[:SOURce&lt;hw&gt;]:BB:W3GPp:BSTation:ENHanced:CHANnel&lt;ch0&gt;:DPCH:DPControl[:POWER]?</code> .....	346

---

**`[:SOURce<hw>]:BB:W3GPp:BSTation:ENHanced:CHANnel<ch0>:DPCH:DPControl:DIRection <Direction>`**

The command selects the Dynamic Power Control direction. The selected mode determines if the channel power is increased (UP) or decreased (DOWN) by a control signal with high level.

**Parameters:**

<Direction>           UP | DOWN  
\*RST:                UP

**Example:**           see [Example"Configuring the Dynamic Power Control Settings"](#) on page 343

**Manual operation:** See "[Direction](#)" on page 126

---

**`[:SOURce<hw>]:BB:W3GPp:BSTation:ENHanced:CHANnel<ch0>:DPCH:DPControl:MODE <Mode>`**

Selects the control signal source for Dynamic Power Control.

**Parameters:**

<Mode>                TPC | MANual  
\*RST:                EXTErnal

**Example:**           See [Example"Configuring the Dynamic Power Control Settings"](#) on page 343.

**Manual operation:** See "[Mode](#)" on page 126

---

**`[:SOURce<hw>]:BB:W3GPp:BSTation<st>:ENHanced:CHANnel<ch0>:DPCH:DPControl:RANGe:UP <Up>`**

**`[:SOURce<hw>]:BB:W3GPp:BSTation:ENHanced:CHANnel<ch0>:DPCH:DPControl:RANGe:DOWN <Down>`**

The command selects the dynamic range for ranging down the channel power.

**Parameters:**

<Down>               float  
Range:                0 to 60  
Increment:           0.01  
\*RST:                10  
Default unit:        dB



**Example:** see [Example"Configuring the Dynamic Power Control Settings"](#) on page 343

**Manual operation:** See ["Up Range / Down Range"](#) on page 127

**[:SOURce<hw>]:BB:W3GPp:BSTation:ENHanced:CHANnel<ch0>:DPCH:  
DPCControl:STATe <State>**

The command activates/deactivates Dynamic Power Control.

**Parameters:**

<State> 1 | ON | 0 | OFF  
\*RST: 0

**Example:** see [Example"Configuring the Dynamic Power Control Settings"](#) on page 343

**Manual operation:** See ["Dynamic Power Control State"](#) on page 126

**[:SOURce<hw>]:BB:W3GPp:BSTation:ENHanced:CHANnel<ch0>:DPCH:  
DPCControl:STEP:MANual <Manual>**

Sets the control signal for manual mode of Dynamic Power Control.

**Setting parameters:**

<Manual> MAN0 | MAN1  
\*RST: MAN0

**Example:**  
BB:W3GP:BST:ENH:CHAN11:DPCH:DPC:MODE MAN  
BB:W3GP:BST:ENH:CHAN11:DPCH:DPC:STEP 0.5 dB  
BB:W3GP:BST:ENH:CHAN11:DPCH:DPC:STAT ON  
BB:W3GP:BST:ENH:CHAN11:DPCH:DPC:STEP:MAN MAN0

**Usage:** Setting only

**Manual operation:** See ["Mode"](#) on page 126

**[:SOURce<hw>]:BB:W3GPp:BSTation:ENHanced:CHANnel<ch0>:DPCH:  
DPCControl:STEP[:EXtErnal] <External>**

This command sets step width by which – with Dynamic Power Control being switched on - the channel power of the selected enhanced channel is increased or decreased.

**Parameters:**

<External> float  
Range: 0.5 to 6  
Increment: 0.01  
\*RST: 1  
Default unit: dB

**Example:** see [Example"Configuring the Dynamic Power Control Settings"](#) on page 343

**Manual operation:** See ["Power Step"](#) on page 127

---

**[[:SOURce<hw>]:BB:W3GPp:BSTation:ENHanced:CHANnel<ch0>:DPCH:DPControl[:POWER]?**

The command queries the deviation of the channel power (delta POW) from the set power start value of the corresponding enhanced channels.

**Return values:**

<Power> float  
 Range: -60 to 60  
 Increment: 0.01  
 \*RST: 0

**Example:** see [Example "Configuring the Dynamic Power Control Settings"](#) on page 343

**Usage:** Query only

**Manual operation:** See ["Power Control Graph"](#) on page 127

## 5.8.4 Error insertion

[[:SOURce<hw>]:BB:W3GPp:BSTation:ENHanced:CHANnel<ch0>:DPCH:DERRor:BIT:LAYer	346
[[:SOURce<hw>]:BB:W3GPp:BSTation:ENHanced:CHANnel<ch0>:DPCH:DERRor:BIT:RATE	347
[[:SOURce<hw>]:BB:W3GPp:BSTation:ENHanced:CHANnel<ch0>:DPCH:DERRor:BIT:STATE	347
[[:SOURce<hw>]:BB:W3GPp:BSTation:ENHanced:CHANnel<ch0>:DPCH:DERRor:BLOCK:RATE	348
[[:SOURce<hw>]:BB:W3GPp:BSTation:ENHanced:CHANnel<ch0>:DPCH:DERRor:BLOCK:STATE	348
[[:SOURce<hw>]:BB:W3GPp:BSTation[:ENHanced]:CHANnel<ch0>:HSDPa:DERRor:BIT:LAYer	348
[[:SOURce<hw>]:BB:W3GPp:BSTation[:ENHanced]:CHANnel<ch0>:HSDPa:DERRor:BIT:RATE	349
[[:SOURce<hw>]:BB:W3GPp:BSTation[:ENHanced]:CHANnel<ch0>:HSDPa:DERRor:BIT:STATE	349
[[:SOURce<hw>]:BB:W3GPp:BSTation[:ENHanced]:CHANnel<ch0>:HSDPa:DERRor:BLOCK:RATE	349
[[:SOURce<hw>]:BB:W3GPp:BSTation[:ENHanced]:CHANnel<ch0>:HSDPa:DERRor:BLOCK:STATE	350

---

**[[:SOURce<hw>]:BB:W3GPp:BSTation:ENHanced:CHANnel<ch0>:DPCH:DERRor:BIT:LAYer <Layer>**

The command selects the layer in the coding process in which bit errors are inserted.

**Parameters:**

<Layer> TRANsport | PHYSical

**TRANsport**

Transport Layer (Layer 2). This layer is only available when channel coding is active.

**PHYSical**

Physical layer (Layer 1).

\*RST: PHYSical

**Example:**

BB:W3GP:BST:ENH:CHAN13:DPCH:DERR:BIT:LAY PHYS  
selects layer 1 for entering bit errors.

**Manual operation:** See "[Insert Errors On](#)" on page 123

**[ :SOURce<hw>]:BB:W3GPp:BSTation:ENHanced:CHANnel<ch0>:DPCH:DERRor:  
BIT:RATE <Rate>**

The command sets the bit error rate.

**Parameters:**

<Rate> float  
Range: 1E-7 to 0.5  
Increment: 1E-7  
\*RST: 0.001

**Example:**

BB:W3GP:BST:ENH:CHAN13:DPCH:DERR:BIT:RATE 1E-4  
sets a bit error rate of 0.0001.

**Manual operation:** See "[Bit Error Rate](#)" on page 123

**[ :SOURce<hw>]:BB:W3GPp:BSTation:ENHanced:CHANnel<ch0>:DPCH:DERRor:  
BIT:STATE <State>**

The command activates bit error generation or deactivates it.

Bit errors are inserted into the data fields of the enhanced channels. When channel coding is active, it is possible to select the layer in which to insert the errors (the physical or the transport layer, [\[:SOURce<hw>\]:BB:W3GPp:BSTation:ENHanced:CHANnel<ch0>:DPCH:DERRor:BIT:LAYer](#)). When the data source is read out, individual bits are deliberately inverted at random points in the data bit stream at the specified error rate in order to simulate an invalid signal.

**Parameters:**

<State> ON | OFF  
\*RST: 0

**Example:**

BB:W3GP:BST:ENH:CHAN13:DPCH:DERR:BIT:STAT ON  
activates bit error generation.

**Manual operation:** See "[Bit Error State \(Enhanced DPCHs\)](#)" on page 122

---

```
[ :SOURce<hw>]:BB:W3GPp:BSTation:ENHanced:CHANnel<ch0>:DPCH:DERRor:
  BLOCk:RATE <Rate>
```

Sets the block error rate.

**Parameters:**

```
<Rate>          float
                Range:    1E-4 to 0.5
                Increment: 1E-4
                *RST:     0.1
```

**Example:**           BB:W3GP:BST:ENH:CHAN13:DPCH:DERR:BLOC:RATE 1E-2  
sets the block error rate to 0.01.

**Manual operation:** See ["Block Error Rate"](#) on page 123

---

```
[ :SOURce<hw>]:BB:W3GPp:BSTation:ENHanced:CHANnel<ch0>:DPCH:DERRor:
  BLOCk:STATe <State>
```

The command activates or deactivates block error generation. Block error generation is only possible when channel coding is activated.

During block error generation, the CRC checksum is determined and then the last bit is inverted at the specified error probability in order to simulate a defective signal.

**Parameters:**

```
<State>          ON | OFF
                *RST:    0
```

**Example:**           BB:W3GP:BST:ENH:CHAN13:DPCH:CCOD:STAT ON  
activates channel coding.  
BB:W3GP:BST:ENH:CHAN13:DPCH:DERR:BLOC:RATE 5E-1  
sets the block error rate to 0.1.  
BB:W3GP:BST:ENH:CHAN13:DPCH:DERR:BLOC:STAT ON  
activates block error generation.

**Manual operation:** See ["Block Error State"](#) on page 123

---

```
[ :SOURce<hw>]:BB:W3GPp:BSTation[:ENHanced]:CHANnel<ch0>:HSDPa:
  DERRor:BIT:LAYer <Layer>
```

The command selects the layer in the coding process in which bit errors are inserted.

**Parameters:**

```
<Layer>          TRANsport | PHYSical
                TRANsport
                Transport Layer (Layer 2)
                PHYSical
                Physical layer (Layer 1)
                *RST:    PHYSical
```

**Example:** `BB:W3GP:BST:ENH:CHAN12:HSDP:DERR:BIT:LAY PHYS`  
selects layer 1 for entering bit errors.

**Manual operation:** See ["Insert Errors On \(HSDPA H-Set\)"](#) on page 107

**[:SOURCE<hw>]:BB:W3GPp:BSTation[:ENHanced]:CHANnel<ch0>:HSDPa:  
DERRor:BIT:RATE <Rate>**

Sets the bit error rate.

**Parameters:**

<Rate> float  
\*RST: 1E-3

**Example:** `BB:W3GP:BST:ENH:CHAN12:HSDP:DERR:BIT:RATE 1E-4`  
sets a bit error rate of 0.0001.

**Manual operation:** See ["Bit Error Rate \(HSDPA H-Set\)"](#) on page 107

**[:SOURCE<hw>]:BB:W3GPp:BSTation[:ENHanced]:CHANnel<ch0>:HSDPa:  
DERRor:BIT:STATe <State>**

The command activates bit error generation or deactivates it.

Bit errors are inserted into the data stream of the coupled HS-PDSCHs. It is possible to select the layer in which the errors are inserted (physical or transport layer). When the data source is read out, individual bits are deliberately inverted at random points in the data bit stream at the specified error rate in order to simulate an invalid signal.

**Parameters:**

<State> ON | OFF  
\*RST: 0

**Example:** `BB:W3GP:BST:ENH:CHAN12:HSDP:DERR:BIT:STAT ON`  
activates bit error generation.

**Manual operation:** See ["Bit Error State \(HSDPA H-Set\)"](#) on page 107

**[:SOURCE<hw>]:BB:W3GPp:BSTation[:ENHanced]:CHANnel<ch0>:HSDPa:  
DERRor:BLOCK:RATE <Rate>**

The command sets the block error rate.

**Parameters:**

<Rate> float  
Range: 1E-4 to 5E-1  
\*RST: 5E-1

**Example:** `BB:W3GP:BST:ENH:CHAN12:HSDP:DERR:BLOC:RATE 1E-2`  
sets the block error rate to 0.01.

**Manual operation:** See ["Block Error Rate \(HSDPA H-Set\)"](#) on page 107

```
[:SOURce<hw>]:BB:W3GPP:BSTation[:ENHanced]:CHANnel<ch0>:HSDPa:
  DERRor:BLOCk:STATe <State>
```

The command activates or deactivates block error generation. During block error generation, the CRC checksum is determined and then the last bit is inverted at the specified error probability in order to simulate a defective signal.

**Parameters:**

```
<State>          ON | OFF
*RST:           0
```

**Example:**

```
BB:W3GP:BST:ENH:CHAN12:HSDP:DERR:BLOC:RATE 5E-1
sets the block error rate to 0.1.
BB:W3GP:BST:ENH:CHAN12:HSDP:DERR:BLOC:STAT ON
activates block error generation.
```

**Manual operation:** See "[Block Error State \(HSDPA H-Set\)](#)" on page 107

## 5.9 User equipment settings

The `SOURce:BB:W3GPP:MSTation` system contains commands for setting the user equipment. The commands of this system only take effect when the 3GPP FDD standard is activated, the UP transmission direction is selected and the particular user equipment is enabled:

```
SOURce:BB:W3GPP:STATe ON
SOURce:BB:W3GPP:LINK UP
SOURce:BB:W3GPP:MSTation2:STATe ON
```

**MSTation<st>**

The numeric suffix to `MSTation` determines the user equipment. The value range is 1 .. 4. If the suffix is omitted, MS1 is selected.

- [General settings](#)..... 351
- [Compressed mode settings](#)..... 356
- [DPCCH settings](#)..... 357
- [HS-DPCCH settings](#)..... 364
- [DPDCH settings](#)..... 382
- [PCPCH settings](#)..... 386
- [PRACH settings](#)..... 397
- [HSUPA settings](#)..... 406
- [UL-DTX and uplink scheduling settings](#)..... 423
- [Dynamic power control settings](#)..... 427

### 5.9.1 General settings

<code>[[:SOURce&lt;hw&gt;]:BB:W3GPp:MSTation:ADDITIONal:COUNT</code> .....	351
<code>[[:SOURce&lt;hw&gt;]:BB:W3GPp:MSTation:ADDITIONal:POWER:OFFSet</code> .....	351
<code>[[:SOURce&lt;hw&gt;]:BB:W3GPp:MSTation:ADDITIONal:SCODE:STEP</code> .....	352
<code>[[:SOURce&lt;hw&gt;]:BB:W3GPp:MSTation:ADDITIONal:STATe</code> .....	352
<code>[[:SOURce&lt;hw&gt;]:BB:W3GPp:MSTation:ADDITIONal:TDELay:STEP</code> .....	352
<code>[[:SOURce&lt;hw&gt;]:BB:W3GPp:MSTation:PRESet</code> .....	353
<code>[[:SOURce&lt;hw&gt;]:BB:W3GPp:MSTation&lt;st&gt;:MODE</code> .....	353
<code>[[:SOURce&lt;hw&gt;]:BB:W3GPp:MSTation&lt;st&gt;:SCODE</code> .....	354
<code>[[:SOURce&lt;hw&gt;]:BB:W3GPp:MSTation&lt;st&gt;:SCODE:MODE</code> .....	354
<code>[[:SOURce&lt;hw&gt;]:BB:W3GPp:MSTation&lt;st&gt;:STATe</code> .....	354
<code>[[:SOURce&lt;hw&gt;]:BB:W3GPp:MSTation&lt;st&gt;:TDELay</code> .....	355
<code>[[:SOURce&lt;hw&gt;]:BB:W3GPp:LREFerence</code> .....	355

---

#### `[[:SOURce<hw>]:BB:W3GPp:MSTation:ADDITIONal:COUNT <Count>`

The command sets the amount of additional user equipment.

Up to 128 additional user equipment can be simulated - corresponding to a receive signal for a base station with high capacity utilization. The fourth user equipment (UE4) serves as a template for all other stations. The only parameters of the additional user equipment to be modified are the scrambling code and the power.

#### Parameters:

`<Count>` integer  
 Range: 1 to 128  
 \*RST: 4

#### Example:

```
BB:W3GP:MST:ADD:COUN 20
Sets 20 additional user equipment.
BB:W3GP:MST:ADD:POW:OFFS -3.0
Sets the power offset to -3 dB.
BB:W3GP:MST:ADD:SCOD:STEP 1
Sets the step width for increasing the scrambling code to 1.
BB:W3GP:MST:ADD:STAT ON
Connects the 20 user equipment to the 3GPP FDD signal.
```

**Manual operation:** See "[Number of Additional UE](#)" on page 68

---

#### `[[:SOURce<hw>]:BB:W3GPp:MSTation:ADDITIONal:POWER:OFFSet <Offset>`

Sets the power offset of the active channels of the additional user equipment relative to the power of the active channels of the reference station UE4.

The offset applies to all the additional user equipment. The resultant overall power must fall within the range 0 ... - 80 dB. If the value is above or below this range, it is limited automatically.

**Parameters:**

<Offset> float  
 Range: -80 to 0  
 Increment: 0.01  
 \*RST: 0

**Example:** BB:W3GP:MST:ADD:POW:OFFS -3.0  
 sets the offset to -3 dB.

**Manual operation:** See ["Power Offset"](#) on page 68

**[SOURce<hw>]:BB:W3GPP:MSTation:ADDITIONal:SCODE:STEP <Step>**

Sets the step width for increasing the scrambling code of the additional user equipment. The start value is the scrambling code of UE4.

**Parameters:**

<Step> integer  
 Range: 0 to #FFFFFFF

**Example:** BB:W3GP:MST:ADD:SCOD:STEP #H55  
 sets the step width for increasing the scrambling code to #H55.

**Manual operation:** See ["Scrambling Code Step"](#) on page 68

**[SOURce<hw>]:BB:W3GPP:MSTation:ADDITIONal:STATE <State>**

Activates additional user equipment.

**Parameters:**

<State> 1 | ON | 0 | OFF  
 \*RST: 0

**Example:** SOURce1:BB:W3GPP:MSTation:ADDITIONal:STATE ON  
 connects the additional user equipment to the 3GPP FDD signal.

**Manual operation:** See ["State"](#) on page 67

**[SOURce<hw>]:BB:W3GPP:MSTation:ADDITIONal:TDELay:STEP <Step>**

Sets the step width for the time delay of the additional user equipment to one another. The start value is the time delay of UE4.

**Parameters:**

<Step> integer  
 Range: 0 to 38400 (1 frame)  
 \*RST: 0  
 Default unit: chip

**Example:** BB:W3GP:MST:ADD:TDEL:STEP 256  
 shifts each of the user equipment 256 chips apart, starting from the time delay of UE4.



**Manual operation:** See ["Time Delay Step"](#) on page 68

---

### **[:SOURce<hw>]:BB:W3GPp:MSTation:PRESet**

The command produces a standardized default for all the user equipment. The settings correspond to the \*RST values specified for the commands.

All user equipment settings are preset.

**Example:** BB:W3GP:MST:PRESet  
resets all the user equipment settings to default values.

**Usage:** Event

**Manual operation:** See ["Reset User Equipment"](#) on page 57

---

### **[:SOURce<hw>]:BB:W3GPp:MSTation<st>:MODE <Mode>**

The command selects the operating mode for the user equipment.

**Parameters:**

<Mode> PRACH | PCPCh | DPCDch | PPRach | PPCPch

**PRACH**

The user equipment only generates a signal with a physical random access channel (PRACH). This channel is used to set up the user equipment connection with the base station. The channel-specific parameters of the PRACH can be set with the commands :SOURce:BB:W3GPp:MSTation<n>:PRACH:....

**PPRach**

The user equipment only generates a signal with the preamble component of a physical random access channel (PRACH). The parameters of the PRACH preamble can be set with the commands :SOURce:BB:W3GPp:MSTation<n>:PRACH:....

**PCPCh**

The user equipment only generates a signal with a physical common packet channel (PCPCH). This channel is used to transmit packet-oriented services (e.g. SMS). The channel-specific parameters of the PCPCH can be set with the commands :SOURce:BB:W3GPp:MSTation<n>:PCPCh:....

**PPCPch**

The user equipment only generates a signal with the preamble component of a physical common packet channel (PCPCH). The parameters of the PCPCH preamble can be set with the commands :SOURce:BB:W3GPp:MSTation<n>:PCPCh:....

**DPCDch**

The user equipment generates a signal with a dedicated physical control channel (DPCCH), up to 6 dedicated physical data channels (DPDCH), up to one HS-DPCCH channel, up to one E-DPCCH channel and up to four E-DPDCH channels. This signal is used for voice and data transmission.

\*RST: DPCDch

**Example:** BB:W3GP:MST1:MODE DPCD  
switches the user equipment to standard mode - transmission of voice and data.

**Manual operation:** See "Mode" on page 151

**[ :SOURce<hw>]:BB:W3GPp:MSTation<st>:SCODE <SCode>**

The command sets the scrambling code. Long or short scrambling codes can be generated (command [ :SOURce<hw>]:BB:W3GPp:MSTation<st>:SCODE:MODE).

**Parameters:**

<SCode> integer  
Range: #H0 to #FFFFFFF  
\*RST: #H0

**Example:** BB:W3GP:MST2:SCOD #H12  
sets scrambling code #12.

**Manual operation:** See "Scrambling Code (hex)" on page 152

**[ :SOURce<hw>]:BB:W3GPp:MSTation<st>:SCODE:MODE <Mode>**

The command sets the type for the scrambling code. The scrambling code generator can also be deactivated for test purposes.

SHORT is only standardized for the selection :BB:W3GP:MST:MODE DPCDh and :BB:W3GP:MST:MODE PCPCh. But it can also be generated for the PCPCH for test purposes.

**Parameters:**

<Mode> LONG | SHORT | OFF  
\*RST: LONG

**Example:** BB:W3GP:MST2:SCOD:MODE OFF  
deactivates the scrambling code generator.

**Manual operation:** See "Scrambling Mode" on page 152

**[ :SOURce<hw>]:BB:W3GPp:MSTation<st>:STATE <State>**

The command activates and deactivates the specified user equipment.

**Parameters:**

<State> 1 | ON | 0 | OFF  
\*RST: ON

**Example:** BB:W3GP:MST2:STAT OFF  
deactivates user equipment 2.

**Manual operation:** See "Select Basestation/User Equipment" on page 59  
See "State" on page 151

---

**[[:SOURce<hw>]:BB:W3GPp:MSTation<st>:TDElay <TDelay>**

Adds a time shift for the selected user equipment compared to user equipment 1.

**Parameters:**

<TDelay>                    integer  
                                  Range:     0 to 38400  
                                  \*RST:     0  
                                  Default unit: chip

**Example:**

BB:W3GP:MST2:TDEL 256  
 shifts user equipment 2 by 256 chips compared to user equipment 1.

**Manual operation:** See ["Time Delay"](#) on page 153

---

**[[:SOURce<hw>]:BB:W3GPp:LREference <Reference>**

Determines the power reference for the calculation of the output signal power in uplink direction.

**Parameters:**

<Reference>                    RMS | DPCC | PMP | LPP | EDCH | HACK | PCQI

**RMS**  
 RMS Power

**DPCC**  
 First DPCC

**PMP**  
 PRACH Message Part

**LPP**  
 Last PRACH Preamble

**EDCH**  
 Requires R&S SMBVB-K83.  
 First E-DCH

**HACK**  
 Requires R&S SMBVB-K83.  
 First HARQ-ACK

**PCQI**  
 Requires R&S SMBVB-K83.  
 First PCI/CQI

\*RST:                    RMS

**Example:**

SOURce1:BB:W3GPp:LREference RMS

**Manual operation:** See ["Power Reference"](#) on page 60

## 5.9.2 Compressed mode settings

<code>[ :SOURce&lt;hw&gt;]:BB:W3GPp:MSTation&lt;st&gt;:CMODE:METHod</code> .....	356
<code>[ :SOURce&lt;hw&gt;]:BB:W3GPp:MSTation&lt;st&gt;:CMODE:PATtern&lt;ch&gt;:TGD</code> .....	356
<code>[ :SOURce&lt;hw&gt;]:BB:W3GPp:MSTation&lt;st&gt;:CMODE:PATtern&lt;ch&gt;:TGL&lt;di&gt;</code> .....	356
<code>[ :SOURce&lt;hw&gt;]:BB:W3GPp:MSTation&lt;st&gt;:CMODE:PATtern&lt;ch&gt;:TGPL</code> .....	357
<code>[ :SOURce&lt;hw&gt;]:BB:W3GPp:MSTation&lt;st&gt;:CMODE:PATtern&lt;ch&gt;:TGSN</code> .....	357
<code>[ :SOURce&lt;hw&gt;]:BB:W3GPp:MSTation&lt;st&gt;:CMODE:STATe</code> .....	357

---

**`[ :SOURce<hw>]:BB:W3GPp:MSTation<st>:CMODE:METHod <Method>`**

The command selects compressed mode method.

**Parameters:**

`<Method>` HLSCheduling | SF2

**SF2**

The data is compressed by halving the spreading factor.

**HLSCheduling**

The data is compressed by stopping the transmission of the data stream during the transmission gap.

\*RST: SF2

**Example:**

`BB:W3GP:MST2:CMOD:METH HLSC`

selects compressed mode method High Layer Scheduling.

**Manual operation:** See "[Compressed Mode Method - UE](#)" on page 84

---

**`[ :SOURce<hw>]:BB:W3GPp:MSTation<st>:CMODE:PATtern<ch>:TGD <Tgd>`**

Sets the transmission gap distances.

**Parameters:**

`<Tgd>` integer

Range: 3 to 100

\*RST: 15

**Example:**

`BB:W3GP:MST2:CMOD:PATT2:TGD 7`

sets transmission gap distance of pattern 2 to 7 slots.

**Manual operation:** See "[Distance](#)" on page 86

---

**`[ :SOURce<hw>]:BB:W3GPp:MSTation<st>:CMODE:PATtern<ch>:TGL<di> <Tgl>`**

Sets the transmission gap lengths.

**Parameters:**

`<Tgl>` integer

Range: 3 to 14

\*RST: 3

**Example:**

`BB:W3GP:MST2:CMOD:PATT2:TGL1 4`

sets transmission gap length of gap 1 of pattern 2 to 4 slots.

**Manual operation:** See ["Gap Len:"](#) on page 86

---

**[:SOURce<hw>]:BB:W3GPp:MSTation<st>:CMODE:PATtern<ch>:TGPL <Tgpl>**

The command sets the transmission gap pattern lengths. Setting 0 is available only for pattern 2.

The transmission gap pattern lengths of the base station with the same suffix as the selected user equipment is set to the same value.

**Parameters:**

<Tgpl> integer  
 Range: 0 to 100  
 \*RST: 2

**Example:** BB:W3GP:MST2:CMOD:PATT2:TGPL 7  
 sets transmission gap pattern length of pattern 2 to 7 frames.

**Manual operation:** See ["Pattern Len:"](#) on page 87

---

**[:SOURce<hw>]:BB:W3GPp:MSTation<st>:CMODE:PATtern<ch>:TGSN <Tgsn>**

Sets the transmission gap slot number of pattern 1.

**Parameters:**

<Tgsn> integer  
 Range: 0 to 14  
 \*RST: 7

**Example:** BB:W3GP:MST2:CMOD:PATT:TGSN 4  
 sets slot number of pattern 1 to slot 4.

**Manual operation:** See ["At Slot:"](#) on page 86

---

**[:SOURce<hw>]:BB:W3GPp:MSTation<st>:CMODE:STATe <State>**

The command activates/deactivates the compressed mode.

**Parameters:**

<State> ON | OFF  
 \*RST: 0

**Example:** BB:W3GP:MST2:CMOD:STAT ON  
 activates compressed mode for user equipment 2.

**Manual operation:** See ["Compressed Mode State"](#) on page 83

### 5.9.3 DPCCH settings

[:SOURce<hw>]:BB:W3GPp:MSTation<st>:DPCCh:CCODE?..... 358  
 [:SOURce<hw>]:BB:W3GPp:MSTation<st>:DPCCh:FBI:MODE..... 358  
 [:SOURce<hw>]:BB:W3GPp:MSTation<st>:DPCCh:FBI:PATtern..... 359

<code>[ :SOURce&lt;hw&gt;]:BB:W3GPp:MSTation&lt;st&gt;:DPCCh:POWer</code> .....	359
<code>[ :SOURce&lt;hw&gt;]:BB:W3GPp:MSTation&lt;st&gt;:DPCCh:SFORmat</code> .....	359
<code>[ :SOURce&lt;hw&gt;]:BB:W3GPp:MSTation&lt;st&gt;:DPCCh:TFCI</code> .....	360
<code>[ :SOURce&lt;hw&gt;]:BB:W3GPp:MSTation&lt;st&gt;:DPCCh:TFCI:STATe</code> .....	360
<code>[ :SOURce&lt;hw&gt;]:BB:W3GPp:MSTation&lt;st&gt;:DPCCh:TOFFset</code> .....	361
<code>[ :SOURce&lt;hw&gt;]:BB:W3GPp:MSTation&lt;st&gt;:DPCCh:TPC:DATA</code> .....	361
<code>[ :SOURce&lt;hw&gt;]:BB:W3GPp:MSTation&lt;st&gt;:DPCCh:TPC:DATA:DSElect</code> .....	361
<code>[ :SOURce&lt;hw&gt;]:BB:W3GPp:MSTation&lt;st&gt;:DPCCh:TPC:DATA:PATtern</code> .....	362
<code>[ :SOURce&lt;hw&gt;]:BB:W3GPp:MSTation&lt;st&gt;:DPCCh:TPC:MIUse</code> .....	362
<code>[ :SOURce&lt;hw&gt;]:BB:W3GPp:MSTation&lt;st&gt;:DPCCh:TPC:MODE</code> .....	363
<code>[ :SOURce&lt;hw&gt;]:BB:W3GPp:MSTation&lt;st&gt;:DPCCh:TPC:PSTep</code> .....	363
<code>[ :SOURce&lt;hw&gt;]:BB:W3GPp:MSTation&lt;st&gt;:DPCCh:TPC:READ</code> .....	364

---

### `[ :SOURce<hw>]:BB:W3GPp:MSTation<st>:DPCCh:CCODE?`

Queries the channelization code and the modulation branch of the specified channel. The value is fixed.

#### Return values:

<CCode>                    integer  
                               Range:        0 to max

#### Example:

`BB:W3GP:MST1:DPCC:CCOD?`  
 queries the channelization code for DPCC of user equipment 1.  
 Response: `Q, 64`

**Usage:**                    Query only

---

### `[ :SOURce<hw>]:BB:W3GPp:MSTation<st>:DPCCh:FBI:MODE <Mode>`

The command sets the number of bits for the FBI field. With OFF, the FBI field is not used.

**Note:** The former 2-bits long FBI Mode "D2B" according to 3GPP Release 4 specification TS 25.211 is not supported any more.

The command sets the slot format (`[ :SOURce<hw>]:BB:W3GPp:MSTation<st>:DPCCh:SFORmat`) in conjunction with the set TFCI status (`[ :SOURce<hw>]:BB:W3GPp:MSTation<st>:DPCCh:TFCI:STATe`) and the TPC Mode (`[ :SOURce<hw>]:BB:W3GPp:MSTation<st>:DPCCh:TPC:MODE`) to the associated values.

#### Parameters:

<Mode>                    OFF | D1B  
                               \*RST:        OFF

#### Example:

`BB:W3GP:MST1:DPCC:FBI:MODE OFF`  
 an FBI field is not used.

**Manual operation:**    See "[FBI Mode](#)" on page 166

---

```
[ :SOURce<hw>]:BB:W3GPP:MSTation<st>:DPCCh:FBI:PATtern <Pattern>,
<BitCount>
```

The command determines the bit pattern when the `PATtern` data source is selected for the FBI field.

**Parameters:**

`<Pattern>` numeric

The first parameter determines the bit pattern (choice of hexadecimal, octal or binary notation), the second specifies the number of bits to use.

\*RST: #H0

`<BitCount>` integer

Range: 1 to 32

\*RST: 1

**Example:**

`BB:W3GP:MST1:DPCC:FBI:PATT #H3F,8`  
defines the bit pattern of the data for the FBI field.

**Manual operation:** See "[FBI Pattern \(bin\)](#)" on page 166

---

```
[ :SOURce<hw>]:BB:W3GPP:MSTation<st>:DPCCh:POWer <Power>
```

The command defines the channel power for the DPCCH.

**Parameters:**

`<Power>` float

Range: -80 dB to 0 dB

Increment: 0.1 dB

\*RST: 0 dB

**Example:**

`BB:W3GP:MST1:DPCC:POW -10 dB`  
sets the channel power to -10 dB.

**Manual operation:** See "[Power](#)" on page 163

---

```
[ :SOURce<hw>]:BB:W3GPP:MSTation<st>:DPCCh:SFORmat <SFormat>
```

The command sets the slot format for the DPCCH. The slot format defines the structure of the DPCCH slots and the control fields.

Slot formats 0 to 4 are available for the DPCCH channel as defined in the 3GPP Release 7 specification TS 25.211.

**Note:**

The former slot formats 4 and 5 according to 3GPP Release 4 specification TS 25.211 are not supported any more.

The command sets the FBI mode (`[ :SOURCE<hw> ] :BB:W3GPp:MSTation<st> : DPCCh:FBI:MODE`), the TFCI status (`[ :SOURCE<hw> ] :BB:W3GPp:MSTation<st> : DPCCh:TFCI:STATe`) and the TPC Mode (`[ :SOURCE<hw> ] :BB:W3GPp:MSTation<st>:DPCCh:TPC:MODE`) to the associated values.

**Parameters:**

<SFormat> integer  
 Range: 0 to 4  
 \*RST: 0

**Example:**

BB:W3GP:MST2:DPCC:SFOR 3  
 selects slot format 3 for the DPCCH of user equipment 2.

**Manual operation:** See "Slot Format #" on page 164

**[ :SOURCE<hw> ] :BB:W3GPp:MSTation<st> :DPCCh:TFCI <Tfci>**

Sets the value of the TFCI (Transport Format Combination Indicator) field. This value selects a combination of 30 bits, which are divided into two groups of 15 successive slots.

**Parameters:**

<Tfci> integer  
 Range: 0 to 1023  
 \*RST: 0

**Example:**

BB:W3GP:MST1:DPCC:TFCI 21  
 sets the TFCI value to 21.

**Manual operation:** See "TFCI" on page 166

**[ :SOURCE<hw> ] :BB:W3GPp:MSTation<st> :DPCCh:TFCI:STATe <State>**

The command activates the TFCI (Transport Format Combination Indicator) field for the DPCCH.

The command sets the slot format (`[ :SOURCE<hw> ] :BB:W3GPp:MSTation<st> : DPCCh:SFORmat`) in conjunction with the set FBI mode (`[ :SOURCE<hw> ] :BB:W3GPp:MSTation<st>:DPCCh:FBI:MODE`) and the TPC Mode (`[ :SOURCE<hw> ] :BB:W3GPp:MSTation<st>:DPCCh:TPC:MODE`) to the associated values.

**Parameters:**

<State> ON | OFF  
 \*RST: 1

**Example:**

BB:W3GP:MST1:DPCC:TFCI:STAT ON  
 activates the TFCI field.

**Manual operation:** See "Use TFCI" on page 165



---

```
[ :SOURce<hw>]:BB:W3GPp:MSTation<st>:DPCCh:TOFFset <TOffset>
```

Sets the timing offset.

**Parameters:**

<TOffset>                    integer  
                                  Range:     0 to 1024  
                                  Increment: 1024

**Example:**                    BB:W3GP:MST1:DPCC:TOFF?  
 queries the timing offset.

**Manual operation:**    See "DL-UL Timing Offset" on page 164

---

```
[ :SOURce<hw>]:BB:W3GPp:MSTation<st>:DPCCh:TPC:DATA <Data>
```

The command determines the data source for the TPC field of the DPCCH.

**Parameters:**

<Data>                        DLISt | ZERO | ONE | PATTErn |

**DLISt**

A data list is used. The data list is selected with the command  
[\[ :SOURce<hw>\]:BB:W3GPp:MSTation<st>:DPCCh:TPC:DATA:DSElect](#).

**ZERO | ONE**

Internal 0 and 1 data is used.

**PATTErn**

Internal data is used. The bit pattern for the data is defined by  
 the command [\[ :SOURce<hw>\]:BB:W3GPp:MSTation<st>:DPCCh:TPC:DATA:PATTErn](#). The maximum length is 64 bits.

\*RST:                        ZERO

**Example:**                    BB:W3GP:MST2:DPCC:TPC:DATA PATT  
 selects as the data source for the TPC field of user equipment 2  
 the bit pattern defined with the following command.  
 BB:W3GP:MST2:DPCC:TPC:DATA: PATT #H48D0,16  
 defines the bit pattern.

**Manual operation:**    See "TPC Data Source" on page 166

---

```
[ :SOURce<hw>]:BB:W3GPp:MSTation<st>:DPCCh:TPC:DATA:DSElect <DSelect>
```

The command selects the data list when the DLISt data source is selected for the TPC field of the DPCCH.

The files are stored with the fixed file extensions \*.dm\_iqd in a directory of the user's choice. The directory applicable to the commands is defined with the command  
 MEMEMory:CDIR. To access the files in this directory, you only have to give the file name, without the path and the file extension.

**Parameters:****<DSelect>** string**Example:**

BB:W3GP:MST1:DPCC:TPC:DATA DLIS

selects the Data Lists data source.

MMEM:CDIR '/var/user/temp/IQData'

selects the directory for the data lists.

BB:W3GP:MST1:DPCC:TPC:DATA:DSEL 'dpcch\_tpc\_1'

selects the data list dpcch\_tpc1.

**Manual operation:** See "TPC Data Source" on page 166**[ :SOURce<hw>]:BB:W3GPp:MSTation<st>:DPCCh:TPC:DATA:PATtern <Pattern>, <BitCount>**

The command determines the bit pattern for the PATtern data source selection. The maximum length of the bit pattern is 64 bits.

**Parameters:****<Pattern>** numeric**\*RST:** #H0**<BitCount>** integer**Range:** 1 to 64**\*RST:** 1**Example:**

BB:W3GP:MST1:DPCC:TPC:DATA:PATT #B11110000,8

defines the bit pattern of the data for the TPC field.

**Manual operation:** See "TPC Data Source" on page 166**[ :SOURce<hw>]:BB:W3GPp:MSTation<st>:DPCCh:TPC:MISuse <MisUse>**

The command activates "mis-" use of the TPC field (Transmit Power Control) for controlling the channel power of the user equipment.

The bit pattern (see com-

mands :SOURce:BB:W3GPp:MSTation:DPCC:TPC:DATA... ) of the TPC field of the DPCCH is used to control the channel power. A "1" leads to an increase of channel powers, a "0" to a reduction of channel powers. Channel power is limited to the range 0 dB to -60 dB. The step width for the change is defined by the command [ :

SOURce<hw>]:BB:W3GPp:MSTation<st>:DPCCh:TPC:PSTep.

**Note:** "Mis-"using the TPC field is available for UE2, UE3,UE4 only.

**Parameters:****<MisUse>** ON | OFF**\*RST:** 0

**Example:** `BB:W3GP:MST2:DPCC:TPC:MIS ON`  
 activates regulation of the channel power via the bit pattern of the TPC field.

`BB:W3GP:MST2:DPCC:TPC:PST 1 dB`  
 sets the step width for the change of channel power to 1 dB.

**Manual operation:** See ["Misuse TPC for Output Power Control"](#) on page 167

**[ :SOURce<hw>]:BB:W3GPp:MSTation<st>:DPCCh:TPC:MODE <Mode>**

Selects the TPC (Transmit Power Control) mode.

The command sets the slot format (`[ :SOURce<hw>]:BB:W3GPp:MSTation<st>:DPCCh:SFORmat`) in conjunction with the set TFCI status (`[ :SOURce<hw>]:BB:W3GPp:MSTation<st>:DPCCh:TFCI:STATe`) and the FBI Mode (`[ :SOURce<hw>]:BB:W3GPp:MSTation<st>:DPCCh:FBI:MODE`) to the associated values.

**Parameters:**

<Mode> D2B | D4B

**D2B**

A TPC field with a length of 2 bits is used.

**D4B**

A TPC field with a length of 4 bits is used.

A 4 bits long TPC field can be selected, only for Slot Format 4 and disabled FBI and TFCI fields.

\*RST: D2B

**Example:** `BB:W3GP:MST1:DPCC:TPC:MODE D2B`  
 an TPC field with a length of 2 bits is used.

**Manual operation:** See ["TPC Mode"](#) on page 166

**[ :SOURce<hw>]:BB:W3GPp:MSTation<st>:DPCCh:TPC:PSTep <PStep>**

The command sets the level of the power step in dB for controlling the transmit power via the data of the TPC field.

**Parameters:**

<PStep> float

Range: -10 to 10

Increment: 0.01

\*RST: 0

**Example:** `BB:W3GP:MST:DPCC:TPC:MIS ON`  
 activates regulation of the channel power via the bit pattern of the TPC field.

`BB:W3GP:MST:DPCC:TPC:PST 1 dB`  
 sets the step width for the change of channel power to 1 dB.

**Manual operation:** See ["TPC Power Step"](#) on page 168

---

**[[:SOURce<hw>]:BB:W3GPp:MSTation<st>:DPCCh:TPC:READ <Read>**

The command sets the read out mode for the bit pattern of the TPC field of the DPCCH.

The bit pattern is selected with the command

SOUR:BB:W3GPp:MST:DPCC:TPC:DATA:PATT.

**Parameters:**

<Read>

CONTInuous | S0A | S1A | S01A | S10A

**CONTInuous**

The bit pattern is used cyclically.

**S0A**

The bit pattern is used once, then the TPC sequence continues with 0 bits.

**S1A**

The bit pattern is used once, then the TPC sequence continues with 1 bit.

**S01A**

The bit pattern is used once and then the TPC sequence is continued with 0 bits and 1 bit alternately (in multiples, depending on by the symbol rate, for example, 00001111).

**S10A**

The bit pattern is used once and then the TPC sequence is continued with 1 bit and 0 bits alternately (in multiples, depending on by the symbol rate, for example, 11110000).

\*RST: CONTInuous

**Example:**

BB:W3GP:MST2:DPCC:TPC:READ CONT

The selected bit pattern is repeated continuously for the TPC sequence.

**Manual operation:** See "TPC Read Out Mode" on page 167

## 5.9.4 HS-DPCCH settings

### 5.9.4.1 Common settings

[[:SOURce<hw>]:BB:W3GPp:MSTation<st>:DPCCh:HS:STATe.....	364
[[:SOURce<hw>]:BB:W3GPp:MSTation<st>:DPCCh:HS:POWer.....	365
[[:SOURce<hw>]:BB:W3GPp:MSTation<st>:DPCCh:HS:COMPatibility.....	365
[[:SOURce<hw>]:BB:W3GPp:MSTation<st>:DPCCh:HS:CCODE?.....	365
[[:SOURce<hw>]:BB:W3GPp:MSTation<st>:DPCCh:HS:SDELay.....	366
[[:SOURce<hw>]:BB:W3GPp:MSTation<st>:DPCCh:HS:TTIDistance.....	366

---

**[[:SOURce<hw>]:BB:W3GPp:MSTation<st>:DPCCh:HS:STATe <State>**

This command activates or deactivates the HS-DPCCH.

**Parameters:**

<State> 1 | ON | 0 | OFF  
 \*RST: 0

**Example:**

BB:W3GP:MST1:DPCC:HS:STAT ON  
 activates HS-DPCCH.

**Manual operation:** See ["State \(HS-DPCCH\)"](#) on page 176

**[ :SOURce<hw>]:BB:W3GPp:MSTation<st>:DPCCh:HS:POWER <Power>**

Sets the channel power in dB.

The power is set relative to the powers of the other channels. If "Adjust Total Power to 0 dB" is executed ([\[ :SOURce<hw>\]:BB:W3GPp:POWER:ADJUST](#)), the power is normalized to total power for all channels of 0 dB. The power ratio of the individual channels remains unchanged.

**Parameters:**

<Power> float  
 Range: -80 to 0  
 Increment: 0.01  
 \*RST: 0

**Example:**

BB:W3GP:MST1:DPCC:HS:POW -30  
 Sets the channel power to -30 dB.

**Manual operation:** See ["Power \(HS-DPCCH\)"](#) on page 177

**[ :SOURce<hw>]:BB:W3GPp:MSTation<st>:DPCCh:HS:COMPatibility  
 <Compatibility>**

The concept of the graphical user interface for the configuration of HS-DPCCH has been adapted to support simultaneous DC-HSDPA and MIMO operation, as required in 3GPP Release 9 onwards.

This command enables the configuration of the HS-DPCCH settings provided for backwards compatibility (REL7).

**Parameters:**

<Compatibility> REL7 | REL8 | REL8RT  
 \*RST: REL8

**Example:**

BB:W3GP:MST1:DPCC:HS:COMP REL8  
 Sets the compatibility mode to Release 8 and Later.

**Manual operation:** See ["Compatibility Mode \(HS-DPCCH\)"](#) on page 177

**[ :SOURce<hw>]:BB:W3GPp:MSTation<st>:DPCCh:HS:CCODE?**

Queries the channelization code and the modulation branch of the HS-DPCCH.

**Return values:**

<CCode> integer  
 Range: 1 to 64  
 \*RST: 64

**Example:**

BB:W3GP:MST1:DPCC:HS:CCOD?  
 queries the channelization code.  
 Response: Q, 32  
 the channelization code is 32 and the modulation branch is Q.

**Usage:**

Query only

**Manual operation:**

See "Channelization Code" on page 163  
 See "Channelization Code (HS-DPCCH)" on page 178

**[:SOURCE<hw>]:BB:W3GPp:MSTation<st>:DPCCh:HS:SDElay <SDelay>**

Sets the delay between the uplink HS-DPCCH and the frame of uplink DPCH.

**Parameters:**

<SDelay> integer  
 a multiple m of 256 chips according to TS 25.211 7.7  
 Range: 0 to 250  
 \*RST: 101  
 Default unit: \* 256 Chips

**Example:**

BB:W3GP:MST1:DPCC:HS:SDEL 101  
 sets a start delay of 101 x 256 chips.

**Manual operation:**

See "Start Delay" on page 177

**[:SOURCE<hw>]:BB:W3GPp:MSTation<st>:DPCCh:HS:TTIDistance <TtiDistance>**

Selects the distance between two packets in HSDPA packet mode.

**Parameters:**

<TtiDistance> integer  
 Range: 1 to 16  
 \*RST: 5

**Example:**

BB:W3GP:MST1:DPCC:HS:TTID 4  
 selects an Inter TTI Distance of 4 subframes.

**Manual operation:**

See "Inter TTI Distance (Interval)" on page 178

#### 5.9.4.2 Up to Release 7 settings

[:SOURCE<hw>]:BB:W3GPp:MSTation<st>:DPCCh:HS:POACK.....	367
[:SOURCE<hw>]:BB:W3GPp:MSTation<st>:DPCCh:HS:PONACK.....	367
[:SOURCE<hw>]:BB:W3GPp:MSTation<st>:DPCCh:HS:HAPattern.....	367
[:SOURCE<hw>]:BB:W3GPp:MSTation<st>:DPCCh:HS:CQI:PLENgt.....	368
[:SOURCE<hw>]:BB:W3GPp:MSTation<st>:DPCCh:HS:CQI<ch>[:VALues].....	368

<code>[:SOURce&lt;hw&gt;]:BB:W3GPp:MSTation&lt;st&gt;:DPCCh:HS:MIMO[:MODE]</code> .....	369
<code>[:SOURce&lt;hw&gt;]:BB:W3GPp:MSTation&lt;st&gt;:DPCCh:HS:MIMO:POAAck</code> .....	369
<code>[:SOURce&lt;hw&gt;]:BB:W3GPp:MSTation&lt;st&gt;:DPCCh:HS:MIMO:POANack</code> .....	370
<code>[:SOURce&lt;hw&gt;]:BB:W3GPp:MSTation&lt;st&gt;:DPCCh:HS:MIMO:PONack</code> .....	370
<code>[:SOURce&lt;hw&gt;]:BB:W3GPp:MSTation&lt;st&gt;:DPCCh:HS:MIMO:PONNack</code> .....	371
<code>[:SOURce&lt;hw&gt;]:BB:W3GPp:MSTation&lt;st&gt;:DPCCh:HS:MIMO:POCA</code> .....	371
<code>[:SOURce&lt;hw&gt;]:BB:W3GPp:MSTation&lt;st&gt;:DPCCh:HS:MIMO:TTICount</code> .....	372
<code>[:SOURce&lt;hw&gt;]:BB:W3GPp:MSTation&lt;st&gt;:DPCCh:HS:MIMO:TTI&lt;ch0&gt;:HACK</code> .....	372
<code>[:SOURce&lt;hw&gt;]:BB:W3GPp:MSTation&lt;st&gt;:DPCCh:HS:MIMO:TTI&lt;ch0&gt;:PCI</code> .....	373
<code>[:SOURce&lt;hw&gt;]:BB:W3GPp:MSTation&lt;st&gt;:DPCCh:HS:MIMO:TTI&lt;ch0&gt;:CQIType</code> .....	373
<code>[:SOURce&lt;hw&gt;]:BB:W3GPp:MSTation&lt;st&gt;:DPCCh:HS:MIMO:TTI&lt;ch0&gt;:CQI&lt;di&gt;</code> .....	373

---

**`[:SOURce<hw>]:BB:W3GPp:MSTation<st>:DPCCh:HS:POAck <Poack>`**

(Up to Release 7)

Sets the channel power part of the ACK in dB.

**Parameters:**

<code>&lt;Poack&gt;</code>	float
	Range: -10 to 10
	Increment: 0.1
	*RST: 0

**Example:** `BB:W3GP:MST1:DPCC:HS:POAC -2.5dB`  
Sets the channel power part of the ACK to 2.5 dB.

**Manual operation:** See ["Power Offset ACK"](#) on page 189

---

**`[:SOURce<hw>]:BB:W3GPp:MSTation<st>:DPCCh:HS:PONack <PoNack>`**

(Up to Release 7)

Sets the channel power part of the NACK in dB.

**Parameters:**

<code>&lt;PoNack&gt;</code>	float
	Range: -10 to 10
	Increment: 0.1
	*RST: 0

**Example:** `BB:W3GP:MST1:DPCC:HS:PONA -2.5dB`  
Sets the channel power part of the NACK to 2.5 dB.

**Manual operation:** See ["Power Offset NACK"](#) on page 189

---

**`[:SOURce<hw>]:BB:W3GPp:MSTation<st>:DPCCh:HS:HAPattern <HaPattern>`**

(Up to Release 7)

The command enters the pattern for the HARQ-ACK field (Hybrid-ARQ Acknowledgement). One bit is used per HS-DPCCH packet.

**Parameters:**

<HaPattern> string

The pattern is entered as string, the maximum number of entries is 32. Three different characters are permitted.

**1**

The HARQ ACK is sent (ACK). Transmission was successful and correct.

**0**

The NACK is sent (NACK). Transmission was not correct. With an NACK, the UE requests retransmission of the incorrect data.

**-**

Nothing is sent. Transmission is interrupted (Discontinuous Transmission, DTX).

\*RST: <empty>

**Example:**

```
BB:W3GP:MST1:DPCC:HS:COMP REL7
BB:W3GP:MST1:DPCC:HS:HAP "110--110-0"
enters the pattern for the HARQ-ACK field.
```

**Manual operation:** See "[ACK/NACK Pattern](#)" on page 190

**[ :SOURce<hw>]:BB:W3GPp:MSTation<st>:DPCC:HS:CQI:PLENgtH <PLength>**

Sets the length of the CQI sequence.

The values of the CQI sequence are defined with command `[ :SOURce<hw>]:BB:W3GPp:MSTation<st>:DPCC:HS:CQI<ch>[:VALues]`. The pattern is generated cyclically.

**Parameters:**

<PLength> integer

Range: 1 to 10

\*RST: 1

**Example:**

```
BB:W3GP:MST1:DPCC:HS:CQI:PLEN 2
the CQI sequence length is 2 values.
BB:W3GP:MST1:DPCC:HS:CQI1 -1
the first CQI value is -1.
BB:W3GP:MST1:DPCC:HS:CQI2 2
the second CQI value is 2.
```

**Manual operation:** See "[CQI Pattern Length](#)" on page 190

**[ :SOURce<hw>]:BB:W3GPp:MSTation<st>:DPCC:HS:CQI<ch>[:VALues]**  
<Values>

Sets the values of the CQI sequence.



The length of the CQI sequence is defined with command `[ :SOURce<hw> ] :BB:W3GPp:MSTation<st>:DPCC:HS:CQI:PLENgtH`. The pattern is generated cyclically.

**Parameters:**

<Values> integer  
 Value -1 means that no CQI is sent (DTX - Discontinuous Transmission).  
 Range: -1 to 30  
 \*RST: 1

**Example:**

BB:W3GP:MST1:DPCC:HS:CQI:PLEN 2  
 the CQI sequence length is 2 values.  
 BB:W3GP:MST1:DPCC:HS:CQI1 1  
 the first CQI value is -1.  
 BB:W3GP:MST1:DPCC:HS:CQI2 2  
 the second CQI value is 2.

**Manual operation:** See "CQI Values" on page 190

`[ :SOURce<hw> ] :BB:W3GPp:MSTation<st>:DPCC:HS:MIMO[:MODE] <Mode>`

Enables/disables working in MIMO mode for the selected UE.

**Parameters:**

<Mode> 1 | ON | 0 | OFF  
 \*RST: 0

**Example:**

BB:W3GP:MST1:DPCC:HS:MIMO:MODE ON  
 Enables MIMO mode for UE 1.

**Manual operation:** See "MIMO Mode (Up to Release 7)" on page 190

`[ :SOURce<hw> ] :BB:W3GPp:MSTation<st>:DPCC:HS:MIMO:POAAck <PoaAck>`

(up to Release 7)

Sets the power offset  $P_{\text{off\_ACK/ACK}}$  of an ACK/ACK response to two scheduled transport blocks relative to the CQI Power  $P_{\text{CQI}}$  (`[ :SOURce<hw> ] :BB:W3GPp:MSTation<st>:DPCC:HS:POWer`).

The power PACK/ACK used during the HARQ-ACK slots is calculated as:

$$P_{\text{ACK/ACK}} = P_{\text{CQI}} + P_{\text{off\_ACK/ACK}}$$

**Parameters:**

<PoaAck> float  
 Range: -10 to 10  
 Increment: 0.1  
 \*RST: 0

**Example:** BB:W3GP:MST1:DPCC:HS:MIMO:MODE ON  
 Enables MIMO mode for UE 1.  
 BB:W3GP:MST1:DPCC:HS:MIMO:TTI2:HACK AACK  
 Sets the HARQ-ACK to ACK/ACK.  
 BB:W3GP:MST1:DPCC:HS:MIMO:POAA -2.5dB  
 Sets the power offset to -2.5 dB.

**Manual operation:** See "[Power Offset ACK/ACK](#)" on page 192

**[[:SOURce<hw>]:BB:W3GPp:MSTation<st>:DPCCh:HS:MIMO:POANack  
 <PoaNack>**

(up to Release 7)

Sets the power offset  $P_{\text{off\_ACK/NACK}}$  of an ACK/NACK response to two scheduled transport blocks relative to the CQI Power  $P_{\text{CQI}}$  ([[:SOURce<hw>]:BB:W3GPp:MSTation<st>:DPCCh:HS:POWer).

The power  $P_{\text{ACK/NACK}}$  used during the HARQ-ACK slots is calculated as:

$$P_{\text{ACK/NACK}} = P_{\text{CQI}} + P_{\text{off\_ACK/NACK}}$$

**Parameters:**

<PoaNack> float  
 Range: -10 to 10  
 Increment: 0.1  
 \*RST: 0

**Example:** BB:W3GP:MST1:DPCC:HS:MIMO:MODE ON  
 Enables MIMO mode for UE 1.  
 BB:W3GP:MST1:DPCC:HS:MIMO:TTI2:HACK ANAC  
 Sets the HARQ-ACK to ACK/NACK.  
 BB:W3GP:MST1:DPCC:HS:MIMO:POAN -1.5dB  
 Sets the power offset to -1.5 dB.

**Manual operation:** See "[Power Offset ACK/NACK](#)" on page 192

**[[:SOURce<hw>]:BB:W3GPp:MSTation<st>:DPCCh:HS:MIMO:PONack <PoNack>**

(up to Release 7)

Sets the power offset  $P_{\text{off\_NACK/ACK}}$  of an NACK/ACK response to two scheduled transport blocks relative to the CQI Power  $P_{\text{CQI}}$  ([[:SOURce<hw>]:BB:W3GPp:MSTation<st>:DPCCh:HS:POWer).

The power  $P_{\text{NACK/ACK}}$  used during the HARQ-ACK slots is calculated as:

$$P_{\text{NACK/ACK}} = P_{\text{CQI}} + P_{\text{off\_NACK/ACK}}$$

**Parameters:**

<PoNack> float  
 Range: -10 to 10  
 Increment: 0.1  
 \*RST: 0

**Example:**

BB:W3GP:MST1:DPCC:HS:MIMO:MODE ON  
 Enables MIMO mode for UE 1.  
 BB:W3GP:MST1:DPCC:HS:MIMO:TTI2:HACK NACK  
 Sets the HARQ-ACK to NACK/ACK.  
 BB:W3GP:MST1:DPCC:HS:MIMO:PONA -1dB  
 Sets the power offset to -1dB.

**Manual operation:** See "Power Offset NACK/ACK" on page 192

**[[:SOURce<hw>]:BB:W3GPP:MSTation<st>:DPCC:HS:MIMO:PONNack**  
 <PonNack>

(up to Release 7)

Sets the power offset  $P_{\text{off\_NACK/NACK}}$  of a NACK/NACK response to two scheduled transport blocks relative to the CQI Power  $P_{\text{CQI}}$  ([[:SOURce<hw>]:BB:W3GPP:MSTation<st>:DPCC:HS:POWER]).

The power  $P_{\text{NACK/NACK}}$  used during the HARQ-ACK slots is calculated as:

$$P_{\text{NACK/NACK}} = P_{\text{CQI}} + P_{\text{off\_NACK/NACK}}$$

**Parameters:**

<PonNack> float  
 Range: -10 to 10  
 Increment: 0.1  
 \*RST: 0

**Example:**

BB:W3GP:MST1:DPCC:HS:MIMO:MODE ON  
 Enables MIMO mode for UE 1.  
 BB:W3GP:MST1:DPCC:HS:MIMO:TTI2:HACK NNAC  
 Sts the HARQ-ACK to NACK/NACK.  
 BB:W3GP:MST1:DPCC:HS:MIMO:PONN -3dB  
 Sets the power offset to -3dB.

**Manual operation:** See "Power Offset NACK/NACK" on page 192

**[[:SOURce<hw>]:BB:W3GPP:MSTation<st>:DPCC:HS:MIMO:POCA <Poca>**

(up to Release 7)

Sets the power offset  $P_{\text{off\_CQI Type A}}$  of the PCI/CQI slots in case a CQI Type A report is sent relative to the CQI Power  $P_{\text{CQI}}$  ([[:SOURce<hw>]:BB:W3GPP:MSTation<st>:DPCC:HS:POWER]).

The power  $P_{\text{CQI Type A}}$  used during the PCI/CQI slots is calculated as:

$$P_{\text{CQI Type A}} = P_{\text{CQI}} + P_{\text{off\_CQI Type A}}$$

Since the CQI Type B reports are used in a single stream transmission, the power  $P_{\text{CQI Type B}} = P_{\text{CQI}}$ .

**Parameters:**

<Poca> float  
 Range: -10 to 10  
 Increment: 0.1  
 \*RST: 0

**Example:**

```
BB:W3GP:MST1:DPCC:HS:MIMO:MODE ON
Enables MIMO mode for UE 1.
BB:W3GP:MST1:DPCC:HS:MIMO:MODE:TT2:CQIT TADT
Selects CQI Type A Dual TB report for TTI2.
BB:W3GP:MST1:DPCC:HS:MIMO:POCA -4dB
Sets the power offset to -4dB.
```

**Manual operation:** See "[Power Offset CQI Type A](#)" on page 193

**[:SOURCE<hw>]:BB:W3GPp:MSTation<st>:DPCCh:HS:MIMO:TTICount <TtiCount>**

Selects the number of configurable TTI's.

**Parameters:**

<TtiCount> integer  
 Range: 1 to 32  
 \*RST: 1

**Example:**

```
BB:W3GP:MST1:DPCC:HS:MIMO:MODE ON
Enables MIMO mode for UE 1.
BB:W3GP:MST1:DPCC:HS:MIMO:TTIC 4
Sets the number of configurable TTI's to 4.
```

**Manual operation:** See "[Number of TTIs \(Up to Release 7\)](#)" on page 193

**[:SOURCE<hw>]:BB:W3GPp:MSTation<st>:DPCCh:HS:MIMO:TTI<ch0>:HACK <Hack>**

Selects the information transmitted during the HARQ-ACK slot of the corresponding TTI.

**Suffix:**

<ch0> 0..Number of TTI -1

**Parameters:**

<Hack> DTX | SACK | SNACK | AACK | ANACK | NACK | NNACK  
 \*RST: AACK (for TTI 1)

**Example:**

```
BB:W3GP:MST1:DPCC:HS:MIMO:MODE ON
Enables MIMO mode for UE 1.
BB:W3GP:MST1:DPCC:HS:MIMO:TTI2:HACK SACK
Sets the HARQ-ACK to single ACK.
```

**Manual operation:** See ["HARQ-ACK \(Up to Release 7\)"](#) on page 193

---

**[:SOURCE<hw>]:BB:W3GPp:MSTation<st>:DPCC:HS:MIMO:TTI<ch0>:PCI <Pci>**

Selects the PCI value transmitted during the PCI/CQI slots of the corresponding TTI.

**Suffix:**

<ch0> 0..Number of TTI -1

**Parameters:**

<Pci> integer  
 Range: 0 to 3  
 \*RST: 0

**Example:**

BB:W3GP:MST1:DPCC:HS:MIMO:MODE ON

Enables MIMO mode for UE 1.

BB:W3GP:MST1:DPCC:HS:MIMO:TTI2:HACK SACK

Sets the HARQ-ACK to single ACK.

BB:W3GP:MST1:DPCC:HS:MIMO:TTI2:PCI 2

Sets the PCI.

**Manual operation:** See ["PCI \(Up to Release 7\)"](#) on page 193

---

**[:SOURCE<hw>]:BB:W3GPp:MSTation<st>:DPCC:HS:MIMO:TTI<ch0>:CQIType <CqiType>**

Selects the type of the CQI report.

**Suffix:**

<ch0> 0..Number of TTI -1

**Parameters:**

<CqiType> TAST | TADT | TB  
 \*RST: TADT

**Example:**

BB:W3GP:MST1:DPCC:HS:MIMO:MODE ON

Enables MIMO mode for UE 1.

BB:W3GP:MST1:DPCC:HS:MIMO:TTI2:HACK SACK

Ssets the HARQ-ACK to single ACK.

BB:W3GP:MST1:DPCC:HS:MIMO:TTI2:CQIT TADT

Selects CQI Type A dual TB report for TTI2.

**Manual operation:** See ["CQI Type \(Up to Release 7\)"](#) on page 194

---

**[:SOURCE<hw>]:BB:W3GPp:MSTation<st>:DPCC:HS:MIMO:TTI<ch0>:CQI<di> <Cqi>**

Selects the CQI report transmitted during the PCI/CQI slots of the corresponding TTI.

For single stream transmission (BB:W3GP:MST:DPCC:HS:MIMO:TTI:CQI1), this command set the CQI values of the following cases:

- The CQI (the value for CQI Type B report)

- The  $CQI_s$  (the CQI value in case a CQI Type A report when one transport block is preferred)

For dual stream transmission (BB:W3GP:MST:DPCC:HS:MIMO:TTI:CQI2), this command sets:

- The  $CQI_1$ , the first of the two CQI values of CQI Type A report when two transport blocks are preferred
- The  $CQI_2$ , the second of the two CQI values of CQI Type A report when two transport blocks are preferred. The CQI then is calculated as follows:  

$$CQI = 15 * CQI_1 + CQI_2 + 31$$

**Suffix:**

<ch0> 0..Number of TTI -1  
TTI

<di> 1|2  
The suffix  $CQI_{<1|2>}$  distinguishes between  $CQI/CQI_s/CQI_1$  and  $CQI_2$ .

**Parameters:**

<Cqi> integer  
Range: 0 to 30  
\*RST: 0

**Example:**

```
BB:W3GP:MST1:DPCC:HS:MIMO:MODE ON
Enables MIMO mode for UE 1.
BB:W3GP:MST1:DPCC:HS:MIMO:TTI2:HACK SACK
Sets the HARQ-ACK to single ACK.
BB:W3GP:MST1:DPCC:HS:MIMO:TTI2:CQIT TADT
Selects CQI Type A dual TB report for TTI2.
BB:W3GP:MST1:DPCC:HS:MIMO:TTI2:CQI1 1.5
Sets CQI1
BB:W3GP:MST1:DPCC:HS:MIMO:TTI2:CQI2 2
Sets CQI2
```

**Example:**

```
BB:W3GP:MST1:DPCC:HS:MIMO:TTI2:CQIT TAST
Selects CQI Type A single TB report for TTI2.
BB:W3GP:MST1:DPCC:HS:MIMO:TTI2:CQI1 3
Sets CQIS
```

**Example:**

```
BB:W3GP:MST1:DPCC:HS:MIMO:TTI2:CQIT TB
Selects CQI Type B
BB:W3GP:MST1:DPCC:HS:MIMO:TTI2:CQI1 0
Sets CQI
```

**Manual operation:** See "[CQI/CQI<sub>s</sub>/CQI<sub>1</sub>/CQI<sub>2</sub> \(Up to Release 7\)](#)" on page 194

### 5.9.4.3 Release 8 and later (RT) settings

#### Example: HS-DPCCH Scheduling

The following is a simple example intended to explain the principle. Configured is an HS-DPCCH scheduling in MIMO Mode and with "Secondary Cell Enabled = 1".

```
BB:W3GP:MST1:DPCC:HS:COMP REL8
BB:W3GP:MST1:DPCC:HS:TTID 5
BB:W3GP:MST1:DPCC:HS:MMOD ON
BB:W3GP:MST1:DPCC:HS:SC:ENABled 1
BB:W3GP:MST1:DPCC:HS:SC:ACT 0
BB:W3GP:MST1:DPCC:HS:HACK:ROWS 2
BB:W3GP:MST1:DPCC:HS:HACK:REPeat 4
BB:W3GP:MST1:DPCC:HS:ROW0:HACK:FROM 0
BB:W3GP:MST1:DPCC:HS:ROW0:HACK:TO 1
BB:W3GP:MST1:DPCC:HS:ROW0:HACK1 MS_AA_D
BB:W3GP:MST1:DPCC:HS:ROW1:HACK:FROM 3
BB:W3GP:MST1:DPCC:HS:ROW1:HACK:TO 3
BB:W3GP:MST1:DPCC:HS:ROW1:HACK1 MS_NN_NN
BB:W3GP:MST1:DPCC:HS:PCQI:ROWS 2
BB:W3GP:MST1:DPCC:HS:PCQI:REPeat 3
BB:W3GP:MST1:DPCC:HS:ROW0:PCQI:FROM 0
BB:W3GP:MST1:DPCC:HS:ROW0:PCQI:TO 0
BB:W3GP:MST1:DPCC:HS:ROW1:PCQI1:TYPE DTX
BB:W3GP:MST1:DPCC:HS:ROW1:PCQI:FROM 1
BB:W3GP:MST1:DPCC:HS:ROW1:PCQI:TO 1
BB:W3GP:MST1:DPCC:HS:ROW1:PCQI1:TYPE TADT
BB:W3GP:MST1:DPCC:HS:ROW1:PCQI1:CQI1 10
BB:W3GP:MST1:DPCC:HS:ROW1:PCQI1:CQI2 20
BB:W3GP:MST1:DPCC:HS:ROW1:PCQI1:PCI 2
BB:W3GP:MST1:DPCC:HS:STAT ON
```

[ :SOURce<hw>]:BB:W3GPp:MSTation<st>:DPCCCh:HS:SFOFormat?	376
[ :SOURce<hw>]:BB:W3GPp:MSTation<st>:DPCCCh:HS:MMODE	376
[ :SOURce<hw>]:BB:W3GPp:MSTation<st>:DPCCCh:HS:SC:ENABled	376
[ :SOURce<hw>]:BB:W3GPp:MSTation<st>:DPCCCh:HS:SC:ACTive	376
[ :SOURce<hw>]:BB:W3GPp:MSTation<st>:DPCCCh:HS:HACK:ROWS	377
[ :SOURce<hw>]:BB:W3GPp:MSTation<st>:DPCCCh:HS:PCQI:ROWS	377
[ :SOURce<hw>]:BB:W3GPp:MSTation<st>:DPCCCh:HS:ROW<ch0>:HACK:FROM	377
[ :SOURce<hw>]:BB:W3GPp:MSTation<st>:DPCCCh:HS:ROW<ch0>:HACK:TO	377
[ :SOURce<hw>]:BB:W3GPp:MSTation<st>:DPCCCh:HS:ROW<ch0>:HACK<di>	377
[ :SOURce<hw>]:BB:W3GPp:MSTation<st>:DPCCCh:HS:ROW<ch0>:POHAck	379
[ :SOURce<hw>]:BB:W3GPp:MSTation<st>:DPCCCh:HS:ROW<ch0>:PCQI:FROM	379
[ :SOURce<hw>]:BB:W3GPp:MSTation<st>:DPCCCh:HS:ROW<ch0>:PCQI:TO	379
[ :SOURce<hw>]:BB:W3GPp:MSTation<st>:DPCCCh:HS:ROW<ch0>:PCQI<di>:TYPE	379
[ :SOURce<hw>]:BB:W3GPp:MSTation<st>:DPCCCh:HS:ROW<ch0>:PCQI<di>:CQI<us>	380
[ :SOURce<hw>]:BB:W3GPp:MSTation<st>:DPCCCh:HS:ROW<ch0>:PCQI<di>:PCI	380
[ :SOURce<hw>]:BB:W3GPp:MSTation<st>:DPCCCh:HS:ROW<ch0>:POPCqi	380
[ :SOURce<hw>]:BB:W3GPp:MSTation<st>:DPCCCh:HS:HACK:REPeat	381

<a href="#">[:SOURce&lt;hw&gt;]:BB:W3GPp:MSTation&lt;st&gt;:DPCCh:HS:PCQI:REPeat.....</a>	381
<a href="#">[:SOURce&lt;hw&gt;]:BB:W3GPp:MSTation&lt;st&gt;:DPCCh:HS:SLENgth?.....</a>	381
<a href="#">[:SOURce&lt;hw&gt;]:BB:W3GPp:MSTation&lt;st&gt;:DPCCh:HS:SLENgth:ADJust.....</a>	382

---

#### **[:SOURce<hw>]:BB:W3GPp:MSTation<st>:DPCCh:HS:SFORmat?**

Queries the used slot format.

##### **Return values:**

<SlotFormat>            integer  
                           Range:        0 to 1  
                           \*RST:        0

**Usage:**                Query only

**Manual operation:**   See "[Slot Format](#)" on page 179

---

#### **[:SOURce<hw>]:BB:W3GPp:MSTation<st>:DPCCh:HS:MMODE <MMode>**

Enables/disables working in MIMO mode for the selected UE.

##### **Parameters:**

<MMode>                1 | ON | 0 | OFF  
                           \*RST:        0

**Example:**             see [Example"HS-DPCCH Scheduling"](#) on page 375

**Manual operation:**   See "[MIMO Mode](#)" on page 181

---

#### **[:SOURce<hw>]:BB:W3GPp:MSTation<st>:DPCCh:HS:SC:ENABLEd                           <SecCellEnabled>**

Enables the selected number of secondary cells for the selected UE.

##### **Parameters:**

<SecCellEnabled>     integer  
                           Range:        0 to 7  
                           \*RST:        0

**Example:**             see [Example"HS-DPCCH Scheduling"](#) on page 375

**Manual operation:**   See "[Secondary Cell Enabled](#)" on page 181

---

#### **[:SOURce<hw>]:BB:W3GPp:MSTation<st>:DPCCh:HS:SC:ACTive                           <SecCellActive>**

(Release 8 and Later)

Sets the number of active secondary cells for the selected UE.



**Parameters:**

<SecCellActive> integer  
 Range: 0 to 7  
 \*RST: 0

**Example:** see [Example"HS-DPCCH Scheduling"](#) on page 375

**Manual operation:** See ["Secondary Cell Active"](#) on page 182

**[:SOURCE<hw>]:BB:W3GPP:MSTation<st>:DPCCh:HS:HACK:ROWS <RowCount>**  
**[:SOURCE<hw>]:BB:W3GPP:MSTation<st>:DPCCh:HS:PCQI:ROWS <RowCount>**

Determines the number of the rows in the HARQ-ACK respectively in the PCI/CQI scheduling table.

**Parameters:**

<RowCount> integer  
 Range: 1 to 32  
 \*RST: 1

**Example:** See [Example"HS-DPCCH Scheduling"](#) on page 375

**Manual operation:** See ["Number of Rows"](#) on page 185

**[:SOURCE<hw>]:BB:W3GPP:MSTation<st>:DPCCh:HS:ROW<ch0>:HACK:FROM <HackFrom>**  
**[:SOURCE<hw>]:BB:W3GPP:MSTation<st>:DPCCh:HS:ROW<ch0>:HACK:TO <HackTo>**

(Release 8 and later)

Defines the beginning / end of the HARQ-ACK transmissions inside the HARQ-ACK cycle. R&S SMBVBThe range is specified in multiples of intervals (Inter-TTI distance).

**Suffix:**

<ch0> 0..<RowCount>

**Parameters:**

<HackTo> integer  
 Range: 0 to dynamic  
 \*RST: row index

**Example:** See [Example"HS-DPCCH Scheduling"](#) on page 375

**Manual operation:** See ["HARQ-ACK From Interval/ HARQ-ACK To Interval"](#) on page 182

**[:SOURCE<hw>]:BB:W3GPP:MSTation<st>:DPCCh:HS:ROW<ch0>:HACK<di> <HarqAck>**

(Release 8 and Later)

Sets the information transmitted during the HARQ-ACK slots of the TTIs during the corresponding specified HARQ-ACK From/To range.

For detailed description, see "[HS-DPCCH 1/2, HARQ-ACK 1/2/3/4](#)" on page 182. The [Table 5-1](#) provides the necessary cross-reference information.

**Table 5-1: Cross-reference between the used GUI terms and abbreviations in the SCPI command**

Value name	Parameter value
"DTX"	DTX   D_DTX
"PRE, POST"	PRE   POST
"A, N"	A   N
"AA, AN, NA, NN"	M_A   M_N   M_AA   M_AN   M_NA   M_NN
"A/D, N/A, ... " (different combinations possible)	S_A_D   S_N_A   ... (different combinations possible)
"A/D/D, N/D/D, ... " (different combinations possible)	S2_N_N_N   S2_N_N_A   ... (different combinations possible)
"AN/NN, D/AA, ... " (different combinations possible)	MS_AA_AA   MS_D_AA ... (different combinations possible)

**Suffix:**

<ch0>                      0..<RowCount>

**Parameters:**

<HarqAck>

DTX | PRE | POST | A | N | M\_A | M\_N | M\_AA | M\_AN | M\_NA |  
M\_NN | S\_A\_D | S\_N\_D | S\_D\_A | S\_D\_N | S\_A\_A | S\_A\_N |  
S\_N\_A | S\_N\_N | MS\_A\_D | MS\_N\_D | MS\_AA\_D | MS\_AN\_D |  
MS\_NA\_D | MS\_NN\_D | MS\_D\_A | MS\_D\_N | MS\_D\_AA |  
MS\_D\_AN | MS\_D\_NA | MS\_D\_NN | MS\_A\_A | MS\_A\_N |  
MS\_N\_A | MS\_N\_N | MS\_A\_AA | MS\_A\_AN | MS\_A\_NA |  
MS\_A\_NN | MS\_N\_AA | MS\_N\_AN | MS\_N\_NA | MS\_N\_NN |  
MS\_AA\_A | MS\_AA\_N | MS\_AN\_A | MS\_AN\_N | MS\_NA\_A |  
MS\_NA\_N | MS\_NN\_A | MS\_NN\_N | MS\_AA\_AA |  
MS\_AA\_AN | MS\_AA\_NA | MS\_AA\_NN | MS\_AN\_AA |  
MS\_AN\_AN | MS\_AN\_NA | MS\_AN\_NN | MS\_NA\_AA |  
MS\_NA\_AN | MS\_NA\_NA | MS\_NA\_NN | MS\_NN\_AA |  
MS\_NN\_AN | MS\_NN\_NA | MS\_NN\_NN | S2\_A\_D\_D |  
S2\_N\_D\_D | S2\_D\_A\_D | S2\_D\_N\_D | S2\_D\_D\_A |  
S2\_D\_D\_N | S2\_A\_A\_D | S2\_A\_N\_D | S2\_N\_A\_D |  
S2\_N\_N\_D | S2\_A\_D\_A | S2\_A\_D\_N | S2\_N\_D\_A |  
S2\_N\_D\_N | S2\_D\_A\_A | S2\_D\_A\_N | S2\_D\_N\_A |  
S2\_D\_N\_N | S2\_A\_A\_A | S2\_A\_A\_N | S2\_A\_N\_A |  
S2\_A\_N\_N | S2\_N\_A\_A | S2\_N\_A\_N | S2\_N\_N\_A |  
S2\_N\_N\_N | D\_DTX

**Example:**                      See [Example"HS-DPCCH Scheduling"](#) on page 375

**Manual operation:**        See "[HS-DPCCH 1/2, HARQ-ACK 1/2/3/4](#)" on page 182

---

**[ :SOURce<hw>]:BB:W3GPP:MSTation<st>:DPCCh:HS:ROW<ch0>:POHACK**  
 <PoHack>

(Release 8 and Later)

Sets the power offset of a HARQ-ACK response relative to the [ :SOURce<hw>]:BB:W3GPP:MSTation<st>:DPCCh:HS:POWer.

**Suffix:**

<ch0> 0..<RowCount>

**Parameters:**

<PoHack> float  
 Range: -10 to 10  
 Increment: 0.1  
 \*RST: 0

**Manual operation:** See "Power Offset HARQ-ACK" on page 184

---

**[ :SOURce<hw>]:BB:W3GPP:MSTation<st>:DPCCh:HS:ROW<ch0>:PCQI:FROM**  
 <PcqiFrom>

**[ :SOURce<hw>]:BB:W3GPP:MSTation<st>:DPCCh:HS:ROW<ch0>:PCQI:TO**  
 <PcqiTo>

(Release 8 and later)

Defines the beginning / end of the PCI/CQI transmissions inside the PCI/CQI cycle. The range is specified in multiples of intervals (Inter-TTI distance).

**Suffix:**

<ch0> 0..<RowCount>

**Parameters:**

<PcqiTo> integer  
 Range: 0 to dynamic  
 \*RST: row index

**Example:** See [Example"HS-DPCCH Scheduling"](#) on page 375

**Manual operation:** See "[PCI-CQI From Interval/ PCI-CQI To Interval](#)" on page 185

---

**[ :SOURce<hw>]:BB:W3GPP:MSTation<st>:DPCCh:HS:ROW<ch0>:PCQI<di>:**  
**TYPE <CqiType>**

Selects the type of the PCI/CQI report.

**Suffix:**

<ch0> 0..<RowCount>

**Parameters:**

<CqiType> DTX | CQI | TAST | TADT | TB | CCQI  
**TAST|TADT**  
 Type A Single TB, Type A Double TB

**TB**

Type B

**CCQI**

Composite CQI

**Example:** see [Example"HS-DPCCH Scheduling"](#) on page 375**Manual operation:** See ["HS-DPCCH 1/2, PCI/CQI 1/2/3/4 Type"](#) on page 185

```
[ :SOURce<hw>]:BB:W3GPp:MSTation<st>:DPCCh:HS:ROW<ch0>:PCQI<di>:
  CQI<us> <Cqi>
```

**Parameters:**

```
<Cqi>          integer
                Range:    0 to 30
                *RST:    0
```

**Example:** see [Example"HS-DPCCH Scheduling"](#) on page 375**Manual operation:** See ["CQI/CQI<sub>3</sub>/CQI<sub>1</sub>/CQI<sub>2</sub>"](#) on page 187

```
[ :SOURce<hw>]:BB:W3GPp:MSTation<st>:DPCCh:HS:ROW<ch0>:PCQI<di>:PCI
  <PCI>
```

**Suffix:**

```
<ch0>          0..<RowCount>
```

**Parameters:**

```
<PCI>          integer
                Range:    0 to 3
                *RST:    0
```

**Example:** see [Example"HS-DPCCH Scheduling"](#) on page 375**Manual operation:** See ["PCI"](#) on page 187

```
[ :SOURce<hw>]:BB:W3GPp:MSTation<st>:DPCCh:HS:ROW<ch0>:POPCqi
  <PoPcqi>
```

(Release 8 and Later)

Sets the power offset  $P_{\text{off\_PCI/CQI}}$  of all PCI/CQI slots during the corresponding specified PCI/CQI From/To range relative to the `[ :SOURce<hw>]:BB:W3GPp:MSTation<st>:DPCCh:HS:POWER`.

**Suffix:**

```
<ch0>          0..<RowCount>
```

**Parameters:**

<PoPcqi> float  
 Range: -10 to 10  
 Increment: 0.1  
 \*RST: 0

**Manual operation:** See "[Power Offset PCI/CQI](#)" on page 186

**[ :SOURce<hw>]:BB:W3GPp:MSTation<st>:DPCCh:HS:HACK:REPeat <HackRep>**

Defines the cycle length after that the information in the HS-DPCCH scheduling table is read out again from the beginning.

**Parameters:**

<HackRep> integer  
 Range: 1 to dynamic

**Example:** see [Example"HS-DPCCH Scheduling"](#) on page 375

**Manual operation:** See "[HARQ-ACK Repeat After](#)" on page 182

**[ :SOURce<hw>]:BB:W3GPp:MSTation<st>:DPCCh:HS:PCQI:REPeat <PcqiRep>**

(Release 8 and Later)

Defines the cycle length after that the information in the HS-DPCCH scheduling table is read out again from the beginning.

**Parameters:**

<PcqiRep> integer  
 Range: 1 to dynamic  
 \*RST: 1

**Example:** see [Example"HS-DPCCH Scheduling"](#) on page 375

**Manual operation:** See "[PCI/CQI Repeat After](#)" on page 185

**[ :SOURce<hw>]:BB:W3GPp:MSTation<st>:DPCCh:HS:SLENgth?**

(Release 8 and Later)

Queries the suggested and current ARB sequence length.

The current ARB sequence length is adjusted with the command [\[ :SOURce<hw>\]:BB:W3GPp:MSTation<st>:DPCCh:HS:SLENgth:ADJust](#) on page 382.

**Return values:**

<SLength> float

**Example:** BB:W3GP:MST1:DPCC:HS:SLEN?  
 Queries the ARB sequence length

**Usage:** Query only

**Manual operation:** See ["Suggested / Current ARB Seq. Length \(HS-DPCCH\)"](#) on page 187

---

**[:SOURce<hw>]:BB:W3GPp:MSTation<st>:DPCCh:HS:SLENgth:ADJust**

(Release 8 and Later)

Sets the current ARB sequence length to the suggested value.

**Example:** BB:W3GP:MST1:DPCC:HS:SLen:ADJ  
Adjusts the ARB sequence length

**Usage:** Event

**Manual operation:** See ["Adjust ARB Sequence Length \(HS-DPCCH\)"](#) on page 188

## 5.9.5 DPDCH settings

<a href="#">[:SOURce&lt;hw&gt;]:BB:W3GPp:MSTation&lt;st&gt;:CHANnel&lt;ch&gt;:DPDCh:CCODE?</a> .....	382
<a href="#">[:SOURce&lt;hw&gt;]:BB:W3GPp:MSTation&lt;st&gt;:CHANnel&lt;ch&gt;:DPDCh:DATA</a> .....	382
<a href="#">[:SOURce&lt;hw&gt;]:BB:W3GPp:MSTation&lt;st&gt;:CHANnel&lt;ch&gt;:DPDCh:DATA:DSElect</a> .....	383
<a href="#">[:SOURce&lt;hw&gt;]:BB:W3GPp:MSTation&lt;st&gt;:CHANnel&lt;ch&gt;:DPDCh:DATA:PATtern</a> .....	384
<a href="#">[:SOURce&lt;hw&gt;]:BB:W3GPp:MSTation&lt;st&gt;:CHANnel&lt;ch&gt;:DPDCh:SRATE?</a> .....	384
<a href="#">[:SOURce&lt;hw&gt;]:BB:W3GPp:MSTation&lt;st&gt;:DPDCh:FCIO</a> .....	384
<a href="#">[:SOURce&lt;hw&gt;]:BB:W3GPp:MSTation&lt;st&gt;:DPDCh:ORATE</a> .....	385
<a href="#">[:SOURce&lt;hw&gt;]:BB:W3GPp:MSTation&lt;st&gt;:DPDCh:POWER</a> .....	385
<a href="#">[:SOURce&lt;hw&gt;]:BB:W3GPp:MSTation&lt;st&gt;:DPDCh:STATE</a> .....	385

---

**[:SOURce<hw>]:BB:W3GPp:MSTation<st>:CHANnel<ch>:DPDCh:CCODE?**

The command queries the channelization code of the specified channel. The value is fixed and depends on the overall symbol rate of the user equipment.

**Return values:**

<CCode> float

**Example:** BB:W3GP:MST1:CHAN:DPDC:CCOD?  
queries the channelization code for DPDCH 1 of user equipment 1.

**Usage:** Query only

**Manual operation:** See ["Channelization Code"](#) on page 171

---

**[:SOURce<hw>]:BB:W3GPp:MSTation<st>:CHANnel<ch>:DPDCh:DATA <Data>**

The command determines the data source for the selected DPDCH.

For the enhanced channels of user equipment 1 (UE1), this entry is valid when channel coding is deactivated. When channel coding is active, data sources are selected for the transport channels with the com-

mands :BB:W3GPp:MST:CHANnel:DPDCh:DCCH:DATA

and :BB:W3GPp:MST:ENHanced:TCHannel:DATA.

**Parameters:**

<Data> PN9 | PN11 | PN15 | PN16 | PN20 | PN21 | PN23 | DLIS | ZERO | ONE | PATtern

**PNxx**

The pseudo-random sequence generator is used as the data source. Different random sequence lengths can be selected.

**DLIS**

A data list is used. The data list is selected with the command

`[ :SOURCE<hw> ] :BB:W3GPp:MSTation<st> : CHANnel<ch> :DPDCh:DATA:DSElect.`

**ZERO | ONE**

Internal 0 and 1 data is used.

**PATtern**

Internal data is used. The bit pattern for the data is defined by the command `[ :SOURCE<hw> ] :BB:W3GPp:MSTation<st> : CHANnel<ch> :DPDCh:DATA:PATtern.`

\*RST: PN9

**Example:**

BB:W3GP:MST1:CHAN:DPDC:DATA PN11

Selects internal PRBS data with period length  $2^{11}-1$  as the data source.

**Manual operation:** See "[DPDCH Data Source](#)" on page 172

---

`[ :SOURCE<hw> ] :BB:W3GPp:MSTation<st> : CHANnel<ch> :DPDCh:DATA:DSElect <DSelect>`

The command selects the data list for the DLIS data source selection.

The files are stored with the fixed file extensions `*.dm_iqd` in a directory of the user's choice. The directory applicable to the commands is defined with the command `MMEMory:CDIR`. To access the files in this directory, you only have to give the file name, without the path and the file extension.

**Parameters:**

<DSelect> <data list name>

**Example:**

BB:W3GP:MST1:CHAN1:DPDC:DATA DLIS  
selects the Data Lists data source.

MMEM:CDIR '/var/user/temp/IQData'  
selects the directory for the data lists.

BB:W3GP:MST1:CHAN1:DPDC:DATA:DSEL 'dpdch\_13'  
selects the file `dpdch_13` as the data source.

---

```
[ :SOURce<hw>]:BB:W3GPp:MSTation<st>:CHANnel<ch>:DPDCh:DATA:PATtern
<Pattern>, <BitCount>
```

The command enters the bit pattern for the PATtern data source selection. The first parameter determines the bit pattern (choice of hexadecimal, octal or binary notation), the second specifies the number of bits to use.

**Parameters:**

<Pattern>	numeric
	*RST: #H0
<BitCount>	integer
	Range: 1 to 64
	*RST: 1

**Example:**

```
BB:W3GP:MST1:CHAN1:DPDC:DATA PATT
selects the Pattern data source.
BB:W3GP:MST1:CHAN1:DPDC:DATA:PATT #H3F, 8
defines the bit pattern.
```

**Manual operation:** See "[DPDCH Data Source](#)" on page 172

---

```
[ :SOURce<hw>]:BB:W3GPp:MSTation<st>:CHANnel<ch>:DPDCh:SRATe?
```

The command queries the symbol rate of the DPDCH. The symbol rate depends on the overall symbol rate set and cannot be modified.

**Return values:**

<SRate>	D15K   D30K   D60K   D120k   D240k   D480k   D960k
---------	--

**Example:**

```
BB:W3GP:MST4:CHAN2:DPDC:SRAT?
queries the symbol rate of DPDCH 2 of user equipment 4.
Response: 960
the symbol rate is 960 ksps.
```

**Note:**

DPDCH 2 is only active once the overall symbol rate is 2 x 960 ksps or more. When overall symbol rates are less, the error message "???" is returned.

**Usage:** Query only

**Manual operation:** See "[Symbol Rate / State](#)" on page 171

---

```
[ :SOURce<hw>]:BB:W3GPp:MSTation<st>:DPDCh:FCIO <Fcio>
```

The command sets the channelization code to I/O. This mode can only be activated if the overall symbol rate is < 2 x 960 kbps.

**Parameters:**

<Fcio>	ON   OFF
	*RST: OFF



**Example:** `BB:W3GP:MST1:DPDC:FCIO ON`  
sets the channelization code to I/O.

**Manual operation:** See ["Force Channelization Code To I/O"](#) on page 170

**[ :SOURCE<hw>]:BB:W3GPP:MSTation<st>:DPDCh:ORATe <ORate>**

The command sets the overall symbol rate. The overall symbol rate determines the number of DPDCHs as well as their symbol rate and channelization codes.

**Parameters:**

<ORate> D15K | D30K | D60K | D120k | D240k | D480k | D960k |  
D1920k | D2880k | D3840k | D4800k | D5760k

**D15K ... D5760K**

15 ksps ... 6 x 960 ksps

\*RST: D60K

**Example:** `BB:W3GP:MST1:DPDC:ORAT D15K`  
sets the overall symbol rate to 15 ksps. Only DPDCH1 is active, the symbol rate is 15 ksps and the channelization code is 64.

**Manual operation:** See ["Overall Symbol Rate"](#) on page 170

**[ :SOURCE<hw>]:BB:W3GPP:MSTation<st>:DPDCh:POWER <Power>**

Sets the channel power of the DPDCHs. The power entered is relative to the powers of the other channels. If "Adjust Total Power to 0 dB" is executed (`[ :SOURCE<hw>]:BB:W3GPP:POWER:ADJUST`), the power is normalized to a total power for all channels of 0 dB. The power ratios of the individual channels remains unchanged.

**Note:** The uplink channels are not blanked in this mode (duty cycle 100%).

**Parameters:**

<Power> float  
Range: -80 to 0  
Increment: 0.01  
\*RST: 0

**Example:** `BB:W3GP:MST4:DPDC:POW -60dB`  
Sets the channel power for DPDCH 2 of user equipment 4 to -60 dB. The channel power relates to the power of the other channels.

`BB:W3GP:POW:ADJ`

The channel power relates to 0 dB.

**Manual operation:** See ["Channel Power"](#) on page 169

**[ :SOURCE<hw>]:BB:W3GPP:MSTation<st>:DPDCh:STATE <State>**

The command activates or deactivates DPDCHs. This always activates or deactivates all the channels. The number of channels (1...6) is determined by the overall symbol rate.

**Parameters:**

<State> ON | OFF  
 \*RST: OFF

**Example:**

BB:W3GP:MST1:DPDC:STAT ON  
 activates all the DPDCHs.

**Manual operation:** See "State (DPDCH)" on page 169

**5.9.6 PCPCH settings**

[ :SOURce<hw>]:BB:W3GPp:MSTation<st>:PCPCh:CPOWer.....	386
[ :SOURce<hw>]:BB:W3GPp:MSTation<st>:PCPCh:CPSFormat.....	387
[ :SOURce<hw>]:BB:W3GPp:MSTation<st>:PCPCh:DATA.....	387
[ :SOURce<hw>]:BB:W3GPp:MSTation<st>:PCPCh:DATA:DSElect.....	388
[ :SOURce<hw>]:BB:W3GPp:MSTation<st>:PCPCh:DATA:PATtern.....	388
[ :SOURce<hw>]:BB:W3GPp:MSTation<st>:PCPCh:DPOWer.....	388
[ :SOURce<hw>]:BB:W3GPp:MSTation<st>:PCPCh:FBI:MODE.....	389
[ :SOURce<hw>]:BB:W3GPp:MSTation<st>:PCPCh:FBI:PATtern.....	389
[ :SOURce<hw>]:BB:W3GPp:MSTation<st>:PCPCh:MLENgtH.....	389
[ :SOURce<hw>]:BB:W3GPp:MSTation<st>:PCPCh:PLENgtH.....	390
[ :SOURce<hw>]:BB:W3GPp:MSTation<st>:PCPCh:PPOWer.....	390
[ :SOURce<hw>]:BB:W3GPp:MSTation<st>:PCPCh:PPOWer:STEP.....	390
[ :SOURce<hw>]:BB:W3GPp:MSTation<st>:PCPCh:PREPetition.....	391
[ :SOURce<hw>]:BB:W3GPp:MSTation<st>:PCPCh:RAFter.....	391
[ :SOURce<hw>]:BB:W3GPp:MSTation<st>:PCPCh:RARB.....	391
[ :SOURce<hw>]:BB:W3GPp:MSTation<st>:PCPCh:SIGNature.....	392
[ :SOURce<hw>]:BB:W3GPp:MSTation<st>:PCPCh:SRATe.....	392
[ :SOURce<hw>]:BB:W3GPp:MSTation<st>:PCPCh:TFCI.....	393
[ :SOURce<hw>]:BB:W3GPp:MSTation<st>:PCPCh:TIMing:DPOWer:MPARt?.....	393
[ :SOURce<hw>]:BB:W3GPp:MSTation<st>:PCPCh:TIMing:DPOWer:PREAmble?.....	393
[ :SOURce<hw>]:BB:W3GPp:MSTation<st>:PCPCh:TIMing:SOFFset.....	394
[ :SOURce<hw>]:BB:W3GPp:MSTation<st>:PCPCh:TIMing:SPERiod?.....	394
[ :SOURce<hw>]:BB:W3GPp:MSTation<st>:PCPCh:TIMing:TIME:PREMp.....	394
[ :SOURce<hw>]:BB:W3GPp:MSTation<st>:PCPCh:TIMing:TIME:PREPre.....	395
[ :SOURce<hw>]:BB:W3GPp:MSTation<st>:PCPCh:TPC:DATA.....	395
[ :SOURce<hw>]:BB:W3GPp:MSTation<st>:PCPCh:TPC:DATA:DSElect.....	395
[ :SOURce<hw>]:BB:W3GPp:MSTation<st>:PCPCh:TPC:DATA:PATtern.....	396
[ :SOURce<hw>]:BB:W3GPp:MSTation<st>:PCPCh:TPC:READ.....	396

---

**[ :SOURce<hw>]:BB:W3GPp:MSTation<st>:PCPCh:CPOWer <CPower>**

Sets the power of the control component of the PCPCH.

**Parameters:**

<CPower> float  
 Range: -80 to 0  
 Increment: 0.01  
 \*RST: 0

**Example:** BB:W3GP:MST1:PCPC:CPOW -10 dB  
Sets the power to -10 dB.

**Manual operation:** See "[Control Power](#)" on page 240

**[ :SOURce<hw> ]:BB:W3GPp:MSTation<st>:PCPCh:CPSFormat <CpSFormat>**

The command defines the slot format of the control component of the PCPCH.

The slot format sets the associated FBI mode automatically:

- Slot format 0 = FBI OFF
- Slot format 1 = FBI 1 bit
- Slot format 2 = FBI 2 bits

**Parameters:**

<CpSFormat> integer  
Range: 0 to 2  
\*RST: 0

**Example:** BB:W3GP:MST1:PCPC:CPSF 2  
sets slot format 2.

**Manual operation:** See "[Slot Format](#)" on page 241

**[ :SOURce<hw> ]:BB:W3GPp:MSTation<st>:PCPCh:DATA <Data>**

The command determines the data source for the PCPCH.

**Parameters:**

<Data> ZERO | ONE | PATtern | PN9 | PN11 | PN15 | PN16 | PN20 |  
PN21 | PN23 | DLISt

**PNxx**

The pseudo-random sequence generator is used as the data source. Different random sequence lengths can be selected.

**DLISt**

A data list is used. The data list is selected with the command

SOURce:BB:W3GPp:MST:PCPCh:DATA:DSElect [ :  
[SOURce<hw> \]:BB:W3GPp:MSTation<st>:PCPCh:DATA:  
DSElect.](#)

**ZERO | ONE**

Internal 0 and 1 data is used.

**PATtern**

Internal data is used. The bit pattern for the data is defined by the command [ :[SOURce<hw> \]:BB:W3GPp:MSTation<st>:  
PCPCh:DATA:PATtern.](#)

\*RST: PN9

**Example:** BB:W3GP:MST1:PCPC:DATA PN11  
selects internal PRBS data with period length  $2^{11}-1$  as the data source.

**Manual operation:** See ["Data Source"](#) on page 242

---

**[:SOURCE<hw>]:BB:W3GPp:MSTation<st>:PCPCh:DATA:DSElect <DSelect>**

The command selects the data list for the DLIS data source.

The files are stored with the fixed file extensions \*.dm\_iqd in a directory of the user's choice. The directory applicable to the commands is defined with the command `MMEMory:CDIR`. To access the files in this directory, you only have to give the file name, without the path and the file extension.

**Parameters:**

<DSelect>                    string

**Example:**

```
BB:W3GP:MST1:PCPC:DATA DLIS
selects data lists as the data source.
MMEM:CDIR '/var/user/temp/IQData'
selects the directory for the data lists.
BB:W3GP:MST1:PCPC:DATA:DSEL 'pcpch_data'
selects the data list pcpch_data.
```

**Manual operation:** See ["Data Source"](#) on page 242

---

**[:SOURCE<hw>]:BB:W3GPp:MSTation<st>:PCPCh:DATA:PATtern <Pattern>, <BitCount>**

The command determines the bit pattern for the data component when the PATtern data source is selected. The first parameter determines the bit pattern (choice of hexadecimal, octal or binary notation), the second specifies the number of bits to use.

**Parameters:**

<Pattern>                    numeric  
                               \*RST:        #H0

<BitCount>                   integer  
                               Range:        1 to 64  
                               \*RST:        1

**Example:**

```
BB:W3GP:MST:PCPC:DATA:PATT #H3F,8
defines the bit pattern of the data for the DATA component.
```

**Manual operation:** See ["Data Source"](#) on page 242

---

**[:SOURCE<hw>]:BB:W3GPp:MSTation<st>:PCPCh:DPOWER <DPower>**

Sets the power of the data component of the PCPCH.

**Parameters:**

<DPower>                    float  
                               Range:        -80 to 0  
                               Increment:   0.01  
                               \*RST:        0

**Example:** `BB:W3GP:MST1:PCPC:DPOW -10 dB`  
Sets the power to -10 dB.

**Manual operation:** See ["Data Power"](#) on page 240

**[ :SOURce<hw> ]:BB:W3GPp:MSTation<st>:PCPCh:FBI:MODE <Mode>**

The command sets the number of bits (1 or 2) for the FBI field. With OFF, the field is not used.

The FBI pattern automatically sets the associated slot format:

- FBI OFF = Slot format 0
- FBI 1 bit = Slot format 1
- FBI 2 bits = Slot format 2

**Parameters:**

<Mode>                   OFF | D1B | D2B  
\*RST:               OFF

**Example:** `BB:W3GP:MST2:PCPC:FBI:MODE OFF`  
the FBI field is not used.

**Manual operation:** See ["FBI Mode"](#) on page 241

**[ :SOURce<hw> ]:BB:W3GPp:MSTation<st>:PCPCh:FBI:PATtern <Pattern>,  
<BitCount>**

The command determines the bit pattern for the FBI field when the PATtern data source is selected. The maximum length of the pattern is 32 bits. The first parameter determines the bit pattern (choice of hexadecimal, octal or binary notation), the second specifies the number of bits to use.

**Parameters:**

<Pattern>               numeric  
\*RST:               #H0

<BitCount>             integer  
Range:             1 to 32  
\*RST:             1

**Example:** `BB:W3GP:MST1:PCPC:FBI:PATT #H3F,8`  
defines the bit pattern of the data for the FBI field.

**Manual operation:** See ["FBI Pattern"](#) on page 241

**[ :SOURce<hw> ]:BB:W3GPp:MSTation<st>:PCPCh:MLENght <MLength>**

The command sets the length of the message component as a number of frames.

**Parameters:**

<MLength> 1 | 2 Frames  
 Range: 1 to 2  
 \*RST: 1 Frame

**Example:**

BB:W3GP:MST4:PCPC:MLEN 2  
 the length of the message component is 2 frames.

**Manual operation:** See "[Message Length](#)" on page 241

**[:SOURCE<hw>]:BB:W3GPp:MSTation<st>:PCPCh:PLENgtH <PLength>**

The command defines the length of the power control preamble of the PCPCH as a number of slots.

**Parameters:**

<PLength> S0 | S8  
 \*RST: S8

**Example:**

BB:W3GP:MST1:PCPC:PLEN S8  
 sets a length of 8 slots for the power control preamble.

**Manual operation:** See "[Power Control Preamble Length](#)" on page 240

**[:SOURCE<hw>]:BB:W3GPp:MSTation<st>:PCPCh:PPower <PPower>**

Sets the power of the preamble component of the PCPCH. If the preamble is repeated and the power increased with each repetition, this setting specifies the power achieved during the last repetition.

**Parameters:**

<PPower> float  
 Range: -80 to 0  
 Increment: 0.01  
 \*RST: 0

**Example:**

BB:W3GP:MST1:PCPC:PPOW -10 dB  
 Sets the power to -10 dB.  
 BB:W3GP:MST1:PCPC:PPOW:STEP 1 dB  
 Sets an increase in power of 1 dB per preamble repetition.  
 BB:W3GP:MST1:PCPC:PREP 2  
 Sets a sequence of 2 preambles. The power of the first preamble is -9 dB, the power of the second, -1 dB.

**Manual operation:** See "[Preamble Power](#)" on page 239

**[:SOURCE<hw>]:BB:W3GPp:MSTation<st>:PCPCh:PPower:STEP <Step>**

The command defines the step width of the power increase, by which the preamble component of the PCPCH is increased from repetition to repetition. The power during the last repetition corresponds to the power defined by the command [ :  
[SOURCE<hw>\]:BB:W3GPp:MSTation<st>:PCPCh:PPower.](#)

**Parameters:**

<Step> float  
 Range: 0 dB to 10 dB  
 Increment: 0.1 dB  
 \*RST: 0 dB

**Example:**

BB:W3GP:MST1:PCPC:PPOW:STEP 2dB  
 the power of the PCPCH preamble is increased by 2 dB with every repetition.

**Manual operation:** See "[Preamble Power Step](#)" on page 239

**[:SOURce<hw>]:BB:W3GPp:MSTation<st>:PCPCh:PREPetition <PRepetition>**

The command defines the number of PCPCH preamble components.

**Parameters:**

<PRepetition> integer  
 Range: 1 to 10  
 \*RST: 1

**Example:**

BB:W3GP:MST1:PCPC:PREP 3  
 sets three preamble components.

**Manual operation:** See "[Preamble Repetition](#)" on page 239

**[:SOURce<hw>]:BB:W3GPp:MSTation<st>:PCPCh:RAFTer <Repeatafter>**

Sets the number of access slots after that the PCPCH structure is repeated.

**Parameters:**

<Repeatafter> integer  
 Range: 1 to 1000  
 \*RST: 18

**Example:**

See [\[:SOURce<hw>\]:BB:W3GPp:MSTation<st>:PCPCh:RARB](#) on page 391

**Manual operation:** See "[Repeat Structure After \(x Acc. Slots\)](#)" on page 238

**[:SOURce<hw>]:BB:W3GPp:MSTation<st>:PCPCh:RARB <State>**

Enables/disables repeating the selected PCPCH structure during one ARB sequence.

**Parameters:**

<State> 1 | ON | 0 | OFF

**ON**

Within one ARB sequence, the selected PCPCH structure is repeated once.

**OFF**

The selected PCPCH structure can be repeated several time, depending on the structure length (`[ :SOURce<hw> ] :BB :W3GPP:MSTation<st>:PRCh:TIMing:SPERiod?`) and the `[ :SOURce<hw> ] :BB:W3GPP:MSTation<st>:PCPCh:RAFTer`.

\*RST: 1

**Example:**

```
SOURce1:BB:W3GPP:SLenGth 4
SOURce1:BB:W3GPP:MSTation3:PCPCh:TIMing:
SPERiod?
Response: 14
SOURce1:BB:W3GPP:MSTation1:PCPCh:RARb OFF
SOURce1:BB:W3GPP:MSTation1:PCPCh:RAFTer 20
```

**Manual operation:** See ["Repeat Structure After ARB Sequence Length"](#) on page 238

**[ :SOURce<hw> ] :BB:W3GPP:MSTation<st>:PCPCh:SIGNature <Signature>**

The command selects the signature of the PCPCH (see Table 3 in 3GPP TS 25.213 Version 3.4.0 Release 1999).

**Parameters:**

<Signature> integer  
 Range: 0 to 15  
 \*RST: 0

**Example:** `BB:W3GP:MST1:PCPC:SIGN 5`  
 selects signature 5.

**Manual operation:** See ["Signature"](#) on page 240

**[ :SOURce<hw> ] :BB:W3GPP:MSTation<st>:PCPCh:SRATe <SRate>**

The command sets the symbol rate of the PCPCH.

User Equipment 1: When channel coding is active, the symbol rate is limited to the range between 15 and 120 ksps. Values above this limit are automatically set to 120 ksps.

**Parameters:**

<SRate> D15K | D30K | D60K | D120k | D240k | D480k | D960k  
 \*RST: D30K

**Example:** `BB:W3GP:MST1:PCPC:SRAT D15K`  
 sets the symbol rate of the PCPCH of user equipment 1 to 15 ksps.

**Manual operation:** See ["Symbol Rate"](#) on page 241



---

**[[:SOURce<hw>]:BB:W3GPp:MSTation<st>:PCPCh:TFCI <Tfci>**

Sets the value of the TFCI (Transport Format Combination Indicator) field. This value selects a combination of 30 bits, which are divided into two groups of 15 successive slots.

**Parameters:**

<Tfci> integer  
 Range: 0 to 1023  
 \*RST: 0

**Example:** BB:W3GP:MST1:PCPC:TFCI 21  
 sets the TFCI value to 21.

**Manual operation:** See "[TFCI](#)" on page 242

---

**[[:SOURce<hw>]:BB:W3GPp:MSTation<st>:PCPCh:TIMing:DPOWer:MPARt?**

Queries the level correction value for the message part. In case of one UE active, the power of the message part can be calculated by adding the set RF level.

**Return values:**

<MPart> float  
 Range: -80 to 0  
 Increment: 0.01  
 \*RST: 0

**Example:** BB:W3GP:MST3:PCPC:TIM:DPOW:MPAR?  
 queries the level correction value for the message part.  
 Response: 1.2  
 the correction value is 1.2 dB.  
 POW?  
 queries the RF level.  
 Response: 2  
 the RF output level is 2 dBm. The message part power is 3.2 dBm

**Usage:** Query only

**Manual operation:** See "[Delta Power \(Message Part\)](#)" on page 236

---

**[[:SOURce<hw>]:BB:W3GPp:MSTation<st>:PCPCh:TIMing:DPOWer:PREAmble?**

Queries level correction value for the last AICH preamble before the message part. This value is identical to the correction value for the CD preamble. The level of the other preambles can be calculated by subtracting the set Preamble Power Step.

**Return values:**

<PREamble> float  
 Range: -80 to 0  
 Increment: 0.01  
 \*RST: 0

- Example:** `BB:W3GP:MST3:PCPC:TIM:DPOW:PRE?`  
queries the level correction value for the last AICH preamble before the message part.
- Usage:** Query only
- Manual operation:** See "[Delta Power \(Preamble\)](#)" on page 236

**[ :SOURce<hw>]:BB:W3GPp:MSTation<st>:PCPCh:TIMing:SOFFset <SOffset>**

This command defines the start offset of the PCPCH in access slots. The starting time delay in timeslots is calculated according to: 2 x Start Offset.

**Parameters:**

<SOffset> integer  
Range: 1 to 14  
\*RST: 0

- Example:** `BB:W3GP:MST3:PCPC:TIM:SOFF 1`  
the start offset of the PCPCH of UE 3 is 2 access slots.

**Manual operation:** See "[Start Offset #](#)" on page 236

**[ :SOURce<hw>]:BB:W3GPp:MSTation<st>:PCPCh:TIMing:SPERiod?**

Queries the structure length.

**Return values:**

<SPeriod> float

- Example:** See `[ :SOURce<hw>]:BB:W3GPp:MSTation<st>:PCPCh:RARB` on page 391

**Usage:** Query only

**Manual operation:** See "[Structure Length](#)" on page 237

**[ :SOURce<hw>]:BB:W3GPp:MSTation<st>:PCPCh:TIMing:TIME:PREMp <Premp>**

This command defines the AICH Transmission Timing. This parameter defines the time difference between the preamble and the message part. Two modes are defined in the standard. In mode 0, the preamble to message part difference is 3 access slots, in mode 1 it is 4 access slots.

**Parameters:**

<Premp> integer  
Range: 1 to 14  
\*RST: 3

- Example:** `BB:W3GP:MST3:PCPC:TIM:TIME:PREM 3`  
the difference between the preamble and the message part is 3 access slots.

**Manual operation:** See "[Transmission Timing \(Message Part\)](#)" on page 237

---

**[ :SOURce<hw> ] :BB:W3GPp:MSTation<st>:PCPCh:TIMing:TIME:PREPre <Prepre>**

This command defines the time difference between two successive preambles in access slots.

**Parameters:**

<Prepre>                    integer  
                               Range:        1 to 14  
                               \*RST:        3

**Example:**                BB:W3GP:MST3:PCPC:TIM:TIME:PREP 3  
 the time difference between two successive preambles is 3 access slots.

**Manual operation:**    See "[Transmission Timing \(Preamble\)](#)" on page 237

---

**[ :SOURce<hw> ] :BB:W3GPp:MSTation<st>:PCPCh:TPC:DATA <Data>**

The command determines the data source for the TPC field of the PCPCH.

**Parameters:**

<Data>                    ZERO | ONE | PATTErn | DLISt

**DLISt**

A data list is used. The data list is selected with the command  
[\[ :SOURce<hw> \] :BB:W3GPp:MSTation<st>:PCPCh:TPC:DATA:DSElect](#).

**ZERO | ONE**

Internal 0 and 1 data is used.

**PATTErn**

Internal data is used. The bit pattern for the data is defined by the command  
[\[ :SOURce<hw> \] :BB:W3GPp:MSTation<st>:PCPCh:TPC:DATA:PATTErn](#). The maximum length is 64 bits.

\*RST:                    PATTErn

**Example:**                BB:W3GP:MST2:PCPC:TPC:DATA PATT  
 selects as the data source for the TPC field of user equipment 2 the bit pattern defined with the following command.  
 BB:W3GP:MST2:PCPC:TPC:DATA:DATA:PATTErn #H48D0,16  
 defines the bit pattern.

**Manual operation:**    See "[TPC Data Source](#)" on page 242

---

**[ :SOURce<hw> ] :BB:W3GPp:MSTation<st>:PCPCh:TPC:DATA:DSElect <DSelect>**

The command selects the data list when the DLISt data source is selected for the TPC field of the PCPCH.

The files are stored with the fixed file extensions \*.dm\_iqd in a directory of the user's choice. The directory applicable to the commands is defined with the command  
 MMEMoRY:CDIR. To access the files in this directory, you only have to give the file name, without the path and the file extension.

**Parameters:****<DSelect>** string**Example:**

```
BB:W3GP:MST1:PCPC:TPC:DATA DLIS
selects data lists as the data source.
MMEM:CDIR '/var/user/temp/IQData'
selects the directory for the data lists.
BB:W3GP:MST1:PCPC:TPC:DATA:DSEL 'dpcch_tpc_1'
selects the data list dpcch_tpc1.
```

**Manual operation:** See "[TPC Data Source](#)" on page 242

**[ :SOURce<hw>]:BB:W3GPp:MSTation<st>:PCPCh:TPC:DATA:PATtern <Pattern>, <BitCount>**

The command determines the bit pattern for the `PATtern` data source selection. The maximum length of the bit pattern is 64 bits.

**Parameters:**

**<Pattern>** numeric  
**\*RST:** #H0

**<BitCount>** integer  
**Range:** 1 to 64  
**\*RST:** 1

**Example:**

```
BB:W3GP:MST1:PCPC:DATA:PATT #H3F,8
defines the bit pattern of the data for the FBI field.
```

**Manual operation:** See "[TPC Data Source](#)" on page 242

**[ :SOURce<hw>]:BB:W3GPp:MSTation<st>:PCPCh:TPC:READ <Read>**

The command sets the read out mode for the bit pattern of the TPC field of the PCPCH.

The bit pattern is selected with the command `[ :SOURce<hw>]:BB:W3GPp:MSTation<st>:PCPCh:TPC:DATA`.

**Parameters:****<Read>** CONTinuous | S0A | S1A | S01A | S10A**CONTinuous**

The bit pattern is used cyclically.

**S0A**

The bit pattern is used once, then the TPC sequence continues with 0 bits.

**S1A**

The bit pattern is used once, then the TPC sequence continues with 1 bits.

**S01A**

The bit pattern is used once and then the TPC sequence is continued with 0 and 1 bits alternately (in multiples, depending on by the symbol rate, for example, 00001111).

**S10A**

The bit pattern is used once and then the TPC sequence is continued with 1 and 0 bits alternately (in multiples, depending on by the symbol rate, for example, 11110000).

\*RST: CONTInuous

**Example:**

BB:W3GP:MST2:PCPC:TPC:READ CONT

the selected bit pattern is repeated continuously for the TPC sequence.

**Manual operation:** See "Read Out Mode" on page 243

## 5.9.7 PRACH settings

[ :SOURce<hw>]:BB:W3GPp:MSTation<st>:PRACH:ATTiming.....	397
[ :SOURce<hw>]:BB:W3GPp:MSTation<st>:PRACH:CPOWer.....	398
[ :SOURce<hw>]:BB:W3GPp:MSTation<st>:PRACH:DATA.....	398
[ :SOURce<hw>]:BB:W3GPp:MSTation<st>:PRACH:DATA:DSELEct.....	399
[ :SOURce<hw>]:BB:W3GPp:MSTation<st>:PRACH:DATA:PATTerN.....	399
[ :SOURce<hw>]:BB:W3GPp:MSTation<st>:PRACH:DPOWer.....	399
[ :SOURce<hw>]:BB:W3GPp:MSTation<st>:PRACH:MLENgtH.....	400
[ :SOURce<hw>]:BB:W3GPp:MSTation<st>:PRACH:PPOWer.....	400
[ :SOURce<hw>]:BB:W3GPp:MSTation<st>:PRACH:PPOWer:STEP.....	400
[ :SOURce<hw>]:BB:W3GPp:MSTation<st>:PRACH:PREPetition.....	401
[ :SOURce<hw>]:BB:W3GPp:MSTation<st>:PRACH:RAFTer.....	401
[ :SOURce<hw>]:BB:W3GPp:MSTation<st>:PRACH:RARB.....	401
[ :SOURce<hw>]:BB:W3GPp:MSTation<st>:PRACH:SFOrmat.....	402
[ :SOURce<hw>]:BB:W3GPp:MSTation<st>:PRACH:SIGNature.....	402
[ :SOURce<hw>]:BB:W3GPp:MSTation<st>:PRACH:SRATe.....	402
[ :SOURce<hw>]:BB:W3GPp:MSTation<st>:PRACH:TFCI.....	403
[ :SOURce<hw>]:BB:W3GPp:MSTation<st>:PRACH:TIMing:DPOWer:MPARt?.....	403
[ :SOURce<hw>]:BB:W3GPp:MSTation<st>:PRACH:TIMing:DPOWer:MPARt:CONTRol?.....	404
[ :SOURce<hw>]:BB:W3GPp:MSTation<st>:PRACH:TIMing:DPOWer:MPARt:DATA?.....	404
[ :SOURce<hw>]:BB:W3GPp:MSTation<st>:PRACH:TIMing:DPOWer:PREAmble?.....	404
[ :SOURce<hw>]:BB:W3GPp:MSTation<st>:PRACH:TIMing:SOFFset.....	405
[ :SOURce<hw>]:BB:W3GPp:MSTation<st>:PRACH:TIMing:SPERiod?.....	405
[ :SOURce<hw>]:BB:W3GPp:MSTation<st>:PRACH:TIMing:TIME:PREMp.....	405
[ :SOURce<hw>]:BB:W3GPp:MSTation<st>:PRACH:TIMing:TIME:PREPre.....	406

---

### [ :SOURce<hw>]:BB:W3GPp:MSTation<st>:PRACH:ATTiming <AtTiming>

This command defines which AICH Transmission Timing, time difference between the preamble and the message part or the time difference between two successive preambles in access slots, is defined.

**Parameters:**

<AtTiming>           ATT0 | ATT1  
 \*RST:                ATT0

**Example:**

BB:W3GP:MST3:PRAC:ATT ATT1  
 Selects the AICH Transmission Timing as the difference between the preamble and the message part.

**[ :SOURce<hw>]:BB:W3GPp:MSTation<st>:PRACH:CPOWER <CPower>**

The command defines the power of the control component of the PRACH.

**Parameters:**

<CPower>             float  
 Range:               -80 dB to 0 dB  
 Increment:           0.1 dB  
 \*RST:                0 dB

**Example:**

BB:W3GP:MST1:PRAC:CPOW -10 dB  
 sets the power to -10 dB.

**Manual operation:** See "[Control Power](#)" on page 230

**[ :SOURce<hw>]:BB:W3GPp:MSTation<st>:PRACH:DATA <Data>**

The command determines the data source for the PRACH.

**Parameters:**

<Data>               ZERO | ONE | PATtern | PN9 | PN11 | PN15 | PN16 | PN20 |  
 PN21 | PN23 | DLISt

**PNxx**

The pseudo-random sequence generator is used as the data source. Different random sequence lengths can be selected.

**DLISt**

A data list is used. The data list is selected with the command [\[:SOURce<hw>\]:BB:W3GPp:MSTation<st>:PRACH:DATA:DSElect](#).

**ZERO | ONE**

Internal 0 and 1 data is used.

**PATtern**

Internal data is used. The bit pattern for the data is defined by the command [\[:SOURce<hw>\]:BB:W3GPp:MSTation<st>:PRACH:DATA:PATtern](#).

\*RST:                PN9

**Example:**

BB:W3GP:MST1:PRAC:DATA PN11  
 selects internal PRBS data with period length  $2^{11}-1$  as the data source.

**Manual operation:** See "[Data Source](#)" on page 231

---

**[:SOURce<hw>]:BB:W3GPp:MSTation<st>:PRACH:DATA:DSElect <DSelect>**

The command selects the data list for the DLIS data source.

The files are stored with the fixed file extensions \*.dm\_iqd in a directory of the user's choice. The directory applicable to the commands is defined with the command `MMEMory:CDIR`. To access the files in this directory, you only have to give the file name, without the path and the file extension.

**Parameters:**

<DSelect>                    string

**Example:**

```
BB:W3GP:MST1:PRAC:DATA DLIS
selects data lists as the data source.
MMEM:CDIR '/var/user/temp/IQData'
selects the directory for the data lists.
BB:W3GP:MST1:PRAC:DATA:DSEL 'pcpch_data'
selects the data list pcpch_data.
```

**Manual operation:** See "[Data Source](#)" on page 231

---

**[:SOURce<hw>]:BB:W3GPp:MSTation<st>:PRACH:DATA:PATtern <Pattern>, <BitCount>**

The command determines the bit pattern for the data component when the PATtern data source is selected. The first parameter determines the bit pattern (choice of hexadecimal, octal or binary notation), the second specifies the number of bits to use.

**Parameters:**

<Pattern>                    numeric  
                               \*RST:        #H0

<BitCount>                   integer  
                               Range:        1 to 64  
                               \*RST:        1

**Example:**

```
BB:W3GP:MST1:PRAC:DATA:PATT #H3F,8
defines the bit pattern of the data for the DATA component.
```

**Manual operation:** See "[Data Source](#)" on page 231

---

**[:SOURce<hw>]:BB:W3GPp:MSTation<st>:PRACH:DPOWER <DPower>**

The command defines the power of the data component of the PRACH.

**Parameters:**

<DPower>                    float  
                               Range:        -80 dB to 0 dB  
                               Increment:   0.1 dB  
                               \*RST:        0 dB

**Example:**

```
BB:W3GP:MST1:PRAC:DPOW -10 dB
sets the power to -10 dB.
```

**Manual operation:** See ["Data Power"](#) on page 230

**[ :SOURce<hw>]:BB:W3GPp:MSTation<st>:PRACH:MLENgtH <MLength>**

The command sets the length of the message component as a number of frames.

**Parameters:**

<MLength> 1 | 2 Frames  
\*RST: 1

**Example:** BB:W3GP:MST4:PRAC:MLEN 2  
the length of the message component is 2 frames.

**Manual operation:** See ["Message Length"](#) on page 230

**[ :SOURce<hw>]:BB:W3GPp:MSTation<st>:PRACH:PPower <PPower>**

The command defines the power of the preamble component of the PRACH. If the preamble is repeated and the power increased with each repetition, this setting specifies the power achieved during the last repetition.

**Parameters:**

<PPower> float  
Range: -80 dB to 0 dB  
Increment: 0.1 dB  
\*RST: 0 dB

**Example:** BB:W3GP:MST1:PRAC:PPOW -10 dB  
sets the power to -10 dB.  
BB:W3GP:MST1:PRAC:PPOW:STEP 1 dB  
sets an increase in power of 1 dB per preamble repetition.  
BB:W3GP:MST1:PRAC:PREP 2  
sets a sequence of 2 preambles. The power of the first preamble is -9 dB, the power of the second, -1 dB.

**Manual operation:** See ["Preamble Power"](#) on page 228

**[ :SOURce<hw>]:BB:W3GPp:MSTation<st>:PRACH:PPower:STEP <Step>**

The command defines the step width of the power increase, by which the preamble component of the PRACH is increased from repetition to repetition. The power defined during the last repetition corresponds to the power defined by the command [ :SOURce<hw>]:BB:W3GPp:MSTation<st>:PRACH:PPower.

**Parameters:**

<Step> float  
Range: 0 dB to 10 dB  
Increment: 0.1 dB  
\*RST: 0 dB



**Example:** BB:W3GP:MST1:PRAC:PPOW:STEP 2 dB  
the power of the PRACH preamble is increased by 2 dB with every repetition.

**Manual operation:** See "[Preamble Power Step](#)" on page 228

**[ :SOURce<hw>]:BB:W3GPp:MSTation<st>:PRACH:PREPetition <PRepetition>**

The command defines the number of PRACH preamble components.

**Parameters:**

<PRepetition> integer  
Range: 1 to 10  
\*RST: 1

**Example:** BB:W3GP:MST1:PRAC:PREP 3  
sets three preamble components.

**Manual operation:** See "[Preamble Repetition](#)" on page 229

**[ :SOURce<hw>]:BB:W3GPp:MSTation<st>:PRACH:RAFTer <Repeatafter>**

Sets the number of access slots after that the PRACH structure is repeated.

**Parameters:**

<Repeatafter> integer  
Range: 1 to 1000  
\*RST: 11

**Example:** See [\[:SOURce<hw>\]:BB:W3GPp:MSTation<st>:PRACH:RARB](#) on page 401

**Manual operation:** See "[Repeat Structure After \(x Acc. Slots\)](#)" on page 228

**[ :SOURce<hw>]:BB:W3GPp:MSTation<st>:PRACH:RARB <State>**

Enables/disables repeating the selected PRACH structure during one ARB sequence.

**Parameters:**

<State> 1 | ON | 0 | OFF

**ON**

Within one ARB sequence, the selected PRACH structure is repeated once.

**OFF**

The selected PRACH structure can be repeated several time, depending on the structure length ([\[:SOURce<hw>\]:BB:W3GPp:MSTation<st>:PRACH:TIMing:SPERiod?](#)) and the [\[:SOURce<hw>\]:BB:W3GPp:MSTation<st>:PRACH:RAFTer](#).

\*RST: 1

**Example:**           SOURce1:BB:W3GPp:SLENgth 4  
                   SOURce1:BB:W3GPp:MSTation3:PRACH:TIMing:  
                   SPERiod?  
                   Response: 14  
                   SOURce1:BB:W3GPp:MSTation1:PRACH:RARb OFF  
                   SOURce1:BB:W3GPp:MSTation1:PRACH:RAFTer 20

**Manual operation:** See ["Repeat Structure After ARB Sequence Length"](#) on page 227

**[:SOURce<hw>]:BB:W3GPp:MSTation<st>:PRACH:SFORmat <SFormat>**

Defines the slot format of the PRACH.

A change of slot format leads to an automatic change of symbol rate [ :

[SOURce<hw>\]:BB:W3GPp:MSTation<st>:PRACH:SRATe](#)

When channel coding is active, the slot format is predetermined. So in this case, the command has no effect.

**Parameters:**

<SFormat>           0 | 1 | 2 | 3  
                   \*RST:       1

**Example:**           BB:W3GP:MST:PRAC:SFOR 2  
                   sets slot format 2.

**Manual operation:** See ["Slot Format"](#) on page 230

**[:SOURce<hw>]:BB:W3GPp:MSTation<st>:PRACH:SIGNature <Signature>**

The command selects the signature of the PRACH (see Table 3 in 3GPP TS 25.213 Version 3.4.0 Release 1999).

**Parameters:**

<Signature>       integer  
                   Range:       0 to 15  
                   \*RST:       0

**Example:**           BB:W3GP:MST1:PRAC:SIGN 5  
                   selects signature 5.

**Manual operation:** See ["Signature"](#) on page 229

**[:SOURce<hw>]:BB:W3GPp:MSTation<st>:PRACH:SRATe <SRate>**

The command sets the symbol rate of the PRACH.

A change of symbol rate leads to an automatic change of slot format [ :

[SOURce<hw>\]:BB:W3GPp:MSTation<st>:PRACH:SFORmat.](#)

**Parameters:**

<SRate> D15K | D30K | D60K | D120k  
 \*RST: D30K

**Example:**

BB:W3GP:MST1:PRAC:SRAT D15K  
 sets the symbol rate of the PRACH of user equipment 1 to 15 ksp.

**Manual operation:** See "[Symbol Rate](#)" on page 230

**[:SOURCE<hw>]:BB:W3GPp:MSTation<st>:PRACH:TFCI <Tfci>**

Sets the value of the TFCI (Transport Format Combination Indicator) field. This value selects a combination of 30 bits, which are divided into two groups of 15 successive slots.

**Parameters:**

<Tfci> integer  
 Range: 0 to 1023  
 \*RST: 0

**Example:**

BB:W3GP:MST1:PRAC:TFCI 21  
 sets the TFCI value to 21.

**Manual operation:** See "[TFCI](#)" on page 231

**[:SOURCE<hw>]:BB:W3GPp:MSTation<st>:PRACH:TIMing:DPOWER:MPARt?**

Queries the level correction value for the message part. In case of one UE active and "Level Reference" set to "RMS Power", the power of the message part can be calculated by adding the set RF level.

**Return values:**

<MPart> float  
 Range: -80 to 0  
 Increment: 0.01  
 \*RST: 0

**Example:**

BB:W3GP:MST3:PRAC:TIM:DPOW:MPAR?  
 queries the level correction value for the message part.  
 Response: 1.2  
 the correction value is 1.2 dB.  
 POW?  
 queries the RF level.  
 Response: 2  
 the RF output level is 2 dBm. The message part power is 3.2 dBm.

**Usage:** Query only

**Manual operation:** See "[Delta Power \(Message Part\)](#)" on page 225

---

**[ :SOURce<hw>]:BB:W3GPp:MSTation<st>:PRACH:TIMing:DPOWer:MPARt:CONTROL?**

Queries the level correction value for the message control part.

**Return values:**

<Control> float  
 Range: -80 to 0  
 Increment: 0.01  
 \*RST: 0

**Example:**

BB:W3GP:MST3:PRAC:TIM:DPOW:MPAR:CONT?  
 queries the level correction value for the message control part.  
 Response: -3.24  
 the correction value is -3.24 dB.

**Usage:** Query only

**Manual operation:** See "[Delta Power \(Message Part\)](#)" on page 225

---

**[ :SOURce<hw>]:BB:W3GPp:MSTation<st>:PRACH:TIMing:DPOWer:MPARt:DATA?**

Queries the level correction value for the message data part.

**Return values:**

<Data> float  
 Range: -80 to 0  
 Increment: 0.01  
 \*RST: 0

**Example:**

BB:W3GP:MST3:PRAC:TIM:DPOW:MPAR:DATA?  
 queries the level correction value for the message data part.  
 Response: -3.24  
 the correction value is -3.24 dB.

**Usage:** Query only

**Manual operation:** See "[Delta Power \(Message Part\)](#)" on page 225

---

**[ :SOURce<hw>]:BB:W3GPp:MSTation<st>:PRACH:TIMing:DPOWer:PREAmble?**

Queries level correction value for the preamble before the message part.

**Return values:**

<Preamble> float  
 Range: -80 to 0  
 Increment: 0.01  
 \*RST: 0

**Example:**

BB:W3GP:MST3:PRAC:TIM:DPOW:PRE?  
 queries the level correction value for the last preamble before the message part.

**Usage:** Query only

**Manual operation:** See "[Delta Power \(Preamble\)](#)" on page 225

**[ :SOURce<hw>]:BB:W3GPp:MSTation<st>:PRACH:TIMing:SOFFset <SOffset>**

This command defines the start offset of the PRACH in access slots. The starting time delay in timeslots is calculated according to: 2 x Start Offset.

**Parameters:**

<SOffset> integer  
 Range: 1 to 50  
 \*RST: 0

**Example:** BB:W3GP:MST3:PRAC:TIM:SOFF 1  
 the start offset of the PRACH of UE 3 is 2 access slots.

**Manual operation:** See "[Start Offset #](#)" on page 226

**[ :SOURce<hw>]:BB:W3GPp:MSTation<st>:PRACH:TIMing:SPERiod?**

Queries the structure length.

**Return values:**

<SPeriod> float

**Example:** see [ :SOURce<hw>]:BB:W3GPp:MSTation<st>:PRACH:  
[RARB](#) on page 401

**Usage:** Query only

**Manual operation:** See "[Structure Length](#)" on page 226

**[ :SOURce<hw>]:BB:W3GPp:MSTation<st>:PRACH:TIMing:TIME:PREMp <Premp>**

This command defines the AICH Transmission Timing. This parameter defines the time difference between the preamble and the message part. Two modes are defined in the standard. In mode 0, the preamble to message part difference is 3 access slots, in mode 1 it is 4 access slots.

**Parameters:**

<Premp> integer  
 Range: 1 to 14  
 \*RST: 3

**Example:** BB:W3GP:MST3:PRAC:TIM.TIME:PREM 3  
 the difference between the preamble and the message part is 3 access slots.

**Manual operation:** See "[Time Pre->MP](#)" on page 226

**[:SOURce<hw>]:BB:W3GPp:MSTation<st>:PRACh:TIMing:TIME:PREPre <Prepre>**

This command defines the time difference between two successive preambles in access slots.

**Parameters:**

<Prepre>                    integer  
                                  Range:        1 to 14  
                                  \*RST:        3

**Example:**

BB:W3GP:MST3:PRAC:TIM.TIME:PREP 3  
 the time difference between two successive preambles is 3 access slots.

**Manual operation:** See "Time Pre->Pre" on page 226

## 5.9.8 HSUPA settings

[:SOURce<hw>]:BB:W3GPp:MSTation<st>[:HSUPa]:CHANnel<ch>:DPDCh:E:CCODE?.....	407
[:SOURce<hw>]:BB:W3GPp:MSTation<st>[:HSUPa]:CHANnel<ch>:DPDCh:E:DATA.....	408
[:SOURce<hw>]:BB:W3GPp:MSTation<st>[:HSUPa]:CHANnel<ch>:DPDCh:E:DATA: DSElect.....	408
[:SOURce<hw>]:BB:W3GPp:MSTation<st>[:HSUPa]:CHANnel<ch>:DPDCh:E:DATA: PATtern.....	409
[:SOURce<hw>]:BB:W3GPp:MSTation<st>[:HSUPa]:CHANnel<ch>:DPDCh:E:POWER.....	409
[:SOURce<hw>]:BB:W3GPp:MSTation<st>[:HSUPa]:CHANnel<ch>:DPDCh:E:SRATE?.....	409
[:SOURce<hw>]:BB:W3GPp:MSTation<st>[:HSUPa]:DPCCh:E:FRC:CHANnel.....	410
[:SOURce<hw>]:BB:W3GPp:MSTation<st>[:HSUPa]:DPCCh:E:FRC:CRATE?.....	410
[:SOURce<hw>]:BB:W3GPp:MSTation<st>[:HSUPa]:DPCCh:E:FRC:DATA.....	410
[:SOURce<hw>]:BB:W3GPp:MSTation<st>[:HSUPa]:DPCCh:E:FRC:DATA:DSElect.....	411
[:SOURce<hw>]:BB:W3GPp:MSTation<st>[:HSUPa]:DPCCh:E:FRC:DATA:PATtern.....	411
[:SOURce<hw>]:BB:W3GPp:MSTation<st>[:HSUPa]:DPCCh:E:FRC:DERRor:BIT:LAYer.....	412
[:SOURce<hw>]:BB:W3GPp:MSTation<st>[:HSUPa]:DPCCh:E:FRC:DERRor:BIT:RATE.....	412
[:SOURce<hw>]:BB:W3GPp:MSTation<st>[:HSUPa]:DPCCh:E:FRC:DERRor:BIT:STATE.....	412
[:SOURce<hw>]:BB:W3GPp:MSTation<st>[:HSUPa]:DPCCh:E:FRC:DERRor:BLOCK:RATE.....	413
[:SOURce<hw>]:BB:W3GPp:MSTation<st>[:HSUPa]:DPCCh:E:FRC:DERRor:BLOCK:STATE.....	413
[:SOURce<hw>]:BB:W3GPp:MSTation<st>[:HSUPa]:DPCCh:E:FRC:DTX:PATtern.....	413
[:SOURce<hw>]:BB:W3GPp:MSTation<st>[:HSUPa]:DPCCh:E:FRC:DTX:STATE.....	413
[:SOURce<hw>]:BB:W3GPp:MSTation<st>[:HSUPa]:DPCCh:E:FRC:HARQ:SIMulation: MODE.....	414
[:SOURce<hw>]:BB:W3GPp:MSTation<st>[:HSUPa]:DPCCh:E:FRC:HARQ:SIMulation: RVZero.....	414
[:SOURce<hw>]:BB:W3GPp:MSTation<st>[:HSUPa]:DPCCh:E:FRC:HARQ:SIMulation[: STATE].....	414
[:SOURce<hw>]:BB:W3GPp:MSTation<st>[:HSUPa]:DPCCh:E:FRC:HARQ: SIMulation]:PATtern<ch>.....	415
[:SOURce<hw>]:BB:W3GPp:MSTation<st>[:HSUPa]:DPCCh:E:FRC:HPRocesses?.....	415
[:SOURce<hw>]:BB:W3GPp:MSTation<st>[:HSUPa]:DPCCh:E:FRC:MIBRate?.....	415
[:SOURce<hw>]:BB:W3GPp:MSTation<st>[:HSUPa]:DPCCh:E:FRC:MODulation.....	416
[:SOURce<hw>]:BB:W3GPp:MSTation<st>[:HSUPa]:DPCCh:E:FRC:ORATE.....	416

[ :SOURce<hw>]:BB:W3GPp:MSTation<st>[:HSUPa]:DPCCh:E:FRC:PAYBits?.....	416
[ :SOURce<hw>]:BB:W3GPp:MSTation<st>[:HSUPa]:DPCCh:E:FRC:STATE.....	417
[ :SOURce<hw>]:BB:W3GPp:MSTation<st>[:HSUPa]:DPCCh:E:FRC:TBS:INDEX.....	417
[ :SOURce<hw>]:BB:W3GPp:MSTation<st>[:HSUPa]:DPCCh:E:FRC:TBS:TABLE.....	417
[ :SOURce<hw>]:BB:W3GPp:MSTation<st>[:HSUPa]:DPCCh:E:FRC:TTIBits?.....	418
[ :SOURce<hw>]:BB:W3GPp:MSTation<st>[:HSUPa]:DPCCh:E:FRC:TTIEdch.....	418
[ :SOURce<hw>]:BB:W3GPp:MSTation<st>[:HSUPa]:DPCCh:E:FRC:UECategory?.....	419
[ :SOURce<hw>]:BB:W3GPp:MSTation<st>[:HSUPa]:DPCCh:E:CCODE?.....	419
[ :SOURce<hw>]:BB:W3GPp:MSTation<st>[:HSUPa]:DPCCh:E:HBIT.....	419
[ :SOURce<hw>]:BB:W3GPp:MSTation<st>[:HSUPa]:DPCCh:E:POWER.....	419
[ :SOURce<hw>]:BB:W3GPp:MSTation<st>[:HSUPa]:DPCCh:E:RSNumber.....	420
[ :SOURce<hw>]:BB:W3GPp:MSTation<st>[:HSUPa]:DPCCh:E:STATE.....	420
[ :SOURce<hw>]:BB:W3GPp:MSTation<st>[:HSUPa]:DPCCh:E:TFCI.....	420
[ :SOURce<hw>]:BB:W3GPp:MSTation<st>[:HSUPa]:DPDCh:E:FCIO.....	421
[ :SOURce<hw>]:BB:W3GPp:MSTation<st>[:HSUPa]:DPDCh:E:MODulation.....	421
[ :SOURce<hw>]:BB:W3GPp:MSTation<st>[:HSUPa]:DPDCh:E:ORATE.....	421
[ :SOURce<hw>]:BB:W3GPp:MSTation<st>[:HSUPa]:DPDCh:E:STATE.....	422
[ :SOURce<hw>]:BB:W3GPp:MSTation<st>[:HSUPa]:DPDCh:E:TTIEdch.....	422
[ :SOURce<hw>]:BB:W3GPp:MSTation<st>[:HSUPa]:EDCH:TTIEdch.....	422
[ :SOURce<hw>]:BB:W3GPp:MSTation<st>[:HSUPa]:EDCH:REPeat.....	422
[ :SOURce<hw>]:BB:W3GPp:MSTation<st>[:HSUPa]:EDCH:ROW<ch0>:FROM.....	423
[ :SOURce<hw>]:BB:W3GPp:MSTation<st>[:HSUPa]:EDCH:ROW<ch0>:TO.....	423
[ :SOURce<hw>]:BB:W3GPp:MSTation<st>[:HSUPa]:EDCH:ROWCount.....	423

---

**[ :SOURce<hw>]:BB:W3GPp:MSTation<st>[:HSUPa]:CHANnel<ch>:DPDCh:E:CCODE?**

Queries the channelization code and the modulation branch (I or Q) of the E-DPDCH channel.

The channelization code is dependent on the overall symbol rate set and cannot be modified.

**Return values:**

<ChannelCode>      integer

**Example:**

BB:W3GP:MST4:HSUP:CHAN1:DPDC:E:CCOD?

queries the channelization code and the modulation branch (I or Q) of E-DPDCH 1 of user equipment 4.

Response: Q, 32

**Usage:**            Query only

**Manual operation:** See "Channelization Code" on page 208

---

```
[:SOURce<hw>]:BB:W3GPp:MSTation<st>[:HSUPa]:CHANnel<ch>:DPDCh:E:
  DATA <Data>
```

The command selects the data source for the E-DPDCH channel.

**Parameters:**

<Data>

ZERO | ONE | PATTErn | PN9 | PN11 | PN15 | PN16 | PN20 |  
PN21 | PN23 | DLISt

**PNxx**

The pseudo-random sequence generator is used as the data source. Different random sequence lengths can be selected.

**DLISt**

A data list is used. The data list is selected with the command  
SOURce: [:SOURce<hw>]:BB:W3GPp:MSTation<st>[:  
HSUPa]:CHANnel<ch>:DPDCh:E:DATA:DSElect.

**ZERO | ONE**

Internal 0 and 1 data is used.

**PATTErn**

Internal data is used. The bit pattern for the data is defined by  
the command [:SOURce<hw>]:BB:W3GPp:MSTation<st>[:  
HSUPa]:CHANnel<ch>:DPDCh:E:DATA:PATTErn.

\*RST: PN9

**Example:**

SOUR:BB:W3GP:MST1:HSUP:CHAN1:DPDC:E:DATA PN11  
selects internal PRBS data with period length  $2^{11}-1$  as the data source.

**Manual operation:** See "[E-DPDCH Data Source](#)" on page 209

---

```
[:SOURce<hw>]:BB:W3GPp:MSTation<st>[:HSUPa]:CHANnel<ch>:DPDCh:E:
  DATA:DSElect <DSelect>
```

The command selects the data list for the DLISt data source.

The files are stored with the fixed file extensions \*.dm\_iqd in a directory of the user's choice. The directory applicable to the commands is defined with the command MMEMoRY:CDIR. To access the files in this directory, you only have to give the file name, without the path and the file extension.

**Parameters:**

<DSelect>

string

**Example:**

SOUR:BB:W3GP:MST1:CHAN1:DPDC:E:DATA DLIS  
selects data lists as the data source.  
MMEMoRY:CDIR '/var/user/temp/IQData'  
selects the directory for the data lists.  
BB:W3GP:MST1:CHAN1:DPDC:E:DATA:DSEL 'dp1'  
selects the data list dp1.

**Manual operation:** See "[DPDCH Data Source](#)" on page 172  
See "[E-DPDCH Data Source](#)" on page 209



---

```
[ :SOURce<hw>]:BB:W3GPp:MSTation<st>[:HSUPa]:CHANnel<ch>:DPDCh:E:
  DATA:PATtern <Pattern>, <BitCount>
```

The command determines the bit pattern for the data component when the PATtern data source is selected. The first parameter determines the bit pattern (choice of hexadecimal, octal or binary notation), the second specifies the number of bits to use.

**Parameters:**

<Pattern>	numeric
	*RST: #H0
<BitCount>	integer
	Range: 1 to 64
	*RST: 1

**Example:** SOUR:BB:W3GP:MST1:HSUP:CHAN1:DPDC:E:PATT #H3F,8  
defines the bit pattern of the data for the DATA component.

**Manual operation:** See "[E-DPDCH Data Source](#)" on page 209

---

```
[ :SOURce<hw>]:BB:W3GPp:MSTation<st>[:HSUPa]:CHANnel<ch>:DPDCh:E:
  POWer <Power>
```

The command sets the power of the selected E-DPDCH channel.

**Parameters:**

<Power>	float
	Range: -80 dB to 0 dB
	Increment: 0.01
	*RST: 0 dB

**Example:** BB:W3GP:MST1:HSUP:CHAN1:DPDC:E:POW -2.5dB  
sets the power of E-DPDCH channel 1 to 2.5 dB.

**Manual operation:** See "[Channel Power / dB](#)" on page 209

---

```
[ :SOURce<hw>]:BB:W3GPp:MSTation<st>[:HSUPa]:CHANnel<ch>:DPDCh:E:
  SRATe?
```

The command queries the symbol rate and the state of the E-DPDCH channel.

The symbol rate and the state of the channels are dependent on the overall symbol rate set and cannot be modified.

**Return values:**

<SRate>	D15K   D30K   D60K   D120k   D240k   D480k   D960k   D1920k   D2X1920K   D2X960K2X1920K
---------	--

**Example:** BB:W3GP:MST4:HSUP:CHAN1:DPDC:E:SRAT?  
queries the symbol rate of E-DPDCH 1 of user equipment 4.  
Response: 960  
the symbol rate is 960 ksps.

**Usage:** Query only

**Manual operation:** See "[Symbol Rate / State](#)" on page 208

---

**[ :SOURce<hw>]:BB:W3GPp:MSTation<st>[:HSUPa]:DPCCh:E:FRC:CHANnel**  
<Channel>

The command sets the FRC according to TS 25.141 Annex A.10.

**Parameters:**

<Channel> USER | 1 | 2 | 3 | 4 | 5 | 6 | 7 | 8  
\*RST: 4

**Example:** SOUR:BB:W3GP:MST1:HSUP:DPCC:E:FRC:CHAN 4  
sets the FRC to channel 4.

**Manual operation:** See "[Fixed Reference Channel \(FRC\)](#)" on page 198

---

**[ :SOURce<hw>]:BB:W3GPp:MSTation<st>[:HSUPa]:DPCCh:E:FRC:CRATE?**

The command queries the relation between the information bits to binary channel bits.

**Return values:**

<CRate> float

**Example:** SOUR1:BB:W3GP:MST1:HSUP:DPCC:E:FRC:CRAT?  
queries the coding rate.  
Response: 0.705  
the coding rate is 0.705.

**Usage:** Query only

**Manual operation:** See "[Coding Rate \(Ninf/Nbin\)](#)" on page 201

---

**[ :SOURce<hw>]:BB:W3GPp:MSTation<st>[:HSUPa]:DPCCh:E:FRC:DATA <Data>**

Selects the data source for the E-DCH channels, i.e. this parameter affects the corresponding parameter of the E-DPDCH.

**Parameters:**

<Data> PN9 | PN11 | PN15 | PN16 | PN20 | PN21 | PN23 | DLISt |  
ZERO | ONE | PATtern

**PNxx**

The pseudo-random sequence generator is used as the data source. Different random sequence lengths can be selected.

**DLISt**

A data list is used. The data list is selected with the command  
`[ :SOURce<hw>]:BB:W3GPp:MSTation<st>[:HSUPa]:  
DPCCh:E:FRC:DATA:DSElect.`

**ZERO | ONE**

Internal 0 and 1 data is used.

**PATtern**

Internal data is used. The bit pattern for the data is defined by the command `[ :SOURce<hw> ] :BB:W3GPp:MSTation<st> [ :HSUPa ] :DPCCh:E:FRC:DATA:PATtern`. The maximum length is 64 bits.

\*RST: PN9

**Example:**

BB:W3GP:MST:HSUP:DPCC:E:FRC:DATA PATT

Selects as the data source

BB:W3GP:MST:HSUP:DPCC:E:FRC:DATA:PATT #H48D0,16

Defines the bit pattern.

**Manual operation:** See "[Data Source \(E-DCH\)](#)" on page 199

**[ :SOURce<hw> ] :BB:W3GPp:MSTation<st> [ :HSUPa ] :DPCCh:E:FRC:DATA: DSElect <DSelect>**

The command selects the data list when the DLIS data source is selected for E-DCH channels.

The files are stored with the fixed file extensions `*.dm_iqd` in a directory of the user's choice. The directory applicable to the commands is defined with the command `MMEMory:CDIR`. To access the files in this directory, you only have to give the file name, without the path and the file extension.

**Parameters:**

<DSelect> string

**Example:**

BB:W3GP:MST:HSUP:DPCC:E:FRC:DATA DLIS

selects the Data Lists data source.

MMEM:CDIR '/var/user/temp/IQData'

selects the directory for the data lists.

BB:W3GP:MST:HSUP:DPCC:E:FRC:DATA:DSEL 'frc\_1'

selects the data list `frc_1`.

**Manual operation:** See "[Data Source \(E-DCH\)](#)" on page 199

**[ :SOURce<hw> ] :BB:W3GPp:MSTation<st> [ :HSUPa ] :DPCCh:E:FRC:DATA: PATtern <Pattern>, <BitCount>**

The command determines the bit pattern for the PATtern data source selection. The maximum length of the bit pattern is 64 bits.

**Parameters:**

<Pattern> numeric

\*RST: #H0

<BitCount> integer

Range: 1 to 64

\*RST: 1

**Example:** BB:W3GP:MST:HSUP:DPCC:E:FRC:DATA:PATT  
#B11110000,8  
defines the bit pattern of the data for the E-DCH channels.

**Manual operation:** See ["Data Source \(E-DCH\)"](#) on page 199

**[:SOURce<hw>]:BB:W3GPp:MSTation<st>[:HSUPa]:DPCCh:E:FRC:DERRor:BIT:  
LAYer <Layer>**

The command sets the layer in the coding process at which bit errors are inserted.

**Parameters:**

<Layer> TRANsport | PHYSical  
\*RST: PHYSical

**Example:** SOUR:BB:W3GP:MST1:HSUP:DPCC:E:FRC:DERR:BIT:LAY  
TRAN  
sets the bit error insertion to the transport layer.

**Manual operation:** See ["Insert Errors On"](#) on page 205

**[:SOURce<hw>]:BB:W3GPp:MSTation<st>[:HSUPa]:DPCCh:E:FRC:DERRor:BIT:  
RATE <Rate>**

Sets the bit error rate.

**Parameters:**

<Rate> float  
Range: 1E-7 to 0.5  
Increment: 1E-7  
\*RST: 0.001

**Example:** SOUR:BB:W3GP:MST1:HSUP:DPCC:E:FRC:DERR:BIT:RATE  
1e-3  
sets the bit error rate to 1E-3.

**Manual operation:** See ["Bit Error Rate"](#) on page 205

**[:SOURce<hw>]:BB:W3GPp:MSTation<st>[:HSUPa]:DPCCh:E:FRC:DERRor:BIT:  
STATe <State>**

The command activates or deactivates bit error generation.

**Parameters:**

<State> ON | OFF  
\*RST: 0

**Example:** SOUR:BB:W3GP:MST1:HSUP:DPCC:E:FRC:DERR:BIT:STAT  
ON  
activates the bit error state.

**Manual operation:** See ["Bit Error State"](#) on page 205

---

```
[ :SOURce<hw>]:BB:W3GPp:MSTation<st>[:HSUPa]:DPCC:h:E:FRC:DERRor:
BLOCK:RATE <Rate>
```

Sets the block error rate.

**Parameters:**

```
<Rate>          float
                Range:    1E-4 to 0.5
                Increment: 1E-4
                *RST:     0.1
```

**Example:**            SOUR:BB:W3GP:MST1:HSUP:DPCC:E:FRC:DERR:BLOC:  
RATE 1E-3  
sets the block error rate.

**Manual operation:** See "[Block Error Rate](#)" on page 206

---

```
[ :SOURce<hw>]:BB:W3GPp:MSTation<st>[:HSUPa]:DPCC:h:E:FRC:DERRor:
BLOCK:STATe <State>
```

The command activates or deactivates block error generation.

**Parameters:**

```
<State>         ON | OFF
                *RST:     0
```

**Example:**            SOUR:BB:W3GP:MST1:HSUP:DPCC:E:FRC:DERR:BLOC:  
STAT ON  
activates the block error generation.

**Manual operation:** See "[Block Error State](#)" on page 206

---

```
[ :SOURce<hw>]:BB:W3GPp:MSTation<st>[:HSUPa]:DPCC:h:E:FRC:DTX:PATTern
<Pattern>
```

The command sets the user-definable bit pattern for the DTX.

**Parameters:**

```
<Pattern>       string
                *RST:     "1"
```

**Example:**            SOUR:BB:W3GP:MST1:HSUP:DPCC:E:FRC:DTX:PATT  
"11-1-"  
sets the bit pattern for the DTX.

**Manual operation:** See "[User Data \(DTX Pattern\)](#)" on page 202

---

```
[ :SOURce<hw>]:BB:W3GPp:MSTation<st>[:HSUPa]:DPCC:h:E:FRC:DTX:STATe
<State>
```

The command activates or deactivates the DTX (Discontinuous Transmission) mode.

**Parameters:**

<State> ON | OFF  
 \*RST: 0

**Example:**

SOUR:BB:W3GP:MST1:HSUP:DPCC:E:FRC:DTX:STAT ON  
 activates the DTX.

**Manual operation:** See "[State \(DTX\)](#)" on page 202

**[:SOURce<hw>]:BB:W3GPp:MSTation<st>[:HSUPa]:DPCCh:E:FRC:HARQ:  
 SIMulation:MODE <Mode>**

Selects the HARQ simulation mode.

**Parameters:**

<Mode> VHARq  
**VHARq**  
 Simulates basestation feedback.  
 \*RST: HFE

**Example:**

SOUR1:BB:W3GP:MST1:HSUP:DPCC:E:FRC:HARQ:SIM:  
 MODE VHAR  
 Sets simulation mode virtual HARQ.

**Manual operation:** See "[Mode \(HARQ\)](#)" on page 204

**[:SOURce<hw>]:BB:W3GPp:MSTation<st>[:HSUPa]:DPCCh:E:FRC:HARQ:  
 SIMulation:RVZero <RvZero>**

If activated, the same redundancy version is sent, that is, the redundancy version is not adjusted for the next retransmission in case of a received NACK.

**Parameters:**

<RvZero> ON | OFF  
 \*RST: 1

**Example:**

SOUR1:BB:W3GP:MST1:HSUP:DPCC:E:FRC:HARQ:SIM:RVZ  
 ON  
 the same redundancy version is sent for the next retransmission.

**Manual operation:** See "[Always Use Redundancy Version 0 \(HARQ\)](#)" on page 204

**[:SOURce<hw>]:BB:W3GPp:MSTation<st>[:HSUPa]:DPCCh:E:FRC:HARQ:  
 SIMulation[:STATE] <State>**

Activates or deactivates the HARQ simulation mode.

**Parameters:**

<State> ON | OFF  
 \*RST: 0

**Example:** SOUR1:BB:W3GP:MST1:HSUP:DPCC:E:FRC:HARQ:SIM:  
STAT ON  
activates the HARQ simulation mode.

**Manual operation:** See "[State \(HARQ\)](#)" on page 204

**[:SOURce<hw>]:BB:W3GPp:MSTation<st>[:HSUPa]:DPCCh:E:FRC:HARQ[:  
SIMulation]:PATTern<ch> <Pattern>**

Sets the HARQ Pattern. The maximum length of the pattern is 32 bits.

**Parameters:**

<Pattern> string

**Example:** SOUR1:BB:W3GP:MST1:HSUP:DPCC:E:FRC:HARQ:SIM:  
HARQ:PATT 1010  
sets the HARQ simulation pattern.

**Manual operation:** See "[HARQ1..8: ACK/NACK](#)" on page 204

**[:SOURce<hw>]:BB:W3GPp:MSTation<st>[:HSUPa]:DPCCh:E:FRC:  
HPROcesses?**

The command queries the number of HARQ (Hybrid-ARQ Acknowledgement) process.

**Return values:**

<HProcesses> integer  
Range: 1 to 8

**Example:** SOUR:BB:W3GP:MST1:HSUP:DPCC:E:FRC:HPRO?  
queries the number of HARQ processes.  
Response: 5

**Usage:** Query only

**Manual operation:** See "[Number Of HARQ Processes](#)" on page 200

**[:SOURce<hw>]:BB:W3GPp:MSTation<st>[:HSUPa]:DPCCh:E:FRC:MIBRate?**

Queries the maximum information bit rate.

**Return values:**

<MiBRate> float  
Increment: 0.1

**Example:** SOUR:BB:W3GP:MST1:HSUP:DPCC:E:FRC:HPRO?  
Queries the maximum information bit rate.  
Response: 1353.0

**Usage:** Query only

**Manual operation:** See "[Maximum Information Bitrate/kbps](#)" on page 198

---

**[[:SOURce<hw>]:BB:W3GPp:MSTation<st>[:HSUPa]:DPCC:h:E:FRC:MODulation  
<Modulation>**

Sets the modulation used for the selected FRC.

Two modulation schemes are defined: BPSK for FRC 1 - 7 and 4PAM (4 Pulse-Amplitude Modulation) for FRC 8.

**Parameters:**

<Modulation>            BPSK | PAM4  
\*RST:                    BPSK

**Example:**

BB:W3GP:MST1:HSUP:DPCC:E:FRC:CHAN 8  
sets the FRC to channel 8.  
BB:W3GP:MST1:HSUP:DPCC:E:FRC:MOD 4PAM  
sets the modulation.

**Manual operation:** See "[Modulation](#)" on page 199

---

**[[:SOURce<hw>]:BB:W3GPp:MSTation<st>[:HSUPa]:DPCC:h:E:FRC:ORATe  
<ORate>**

Sets the overall symbol rate for the E-DCH channels, i.e. this parameter affects the corresponding parameter of the E-DPDCH.

**Parameters:**

<ORate>                    D15K | D30K | D60K | D120k | D240k | D480k | D960k |  
D1920k | D2X1920K | D2X960K2X1920K  
\*RST:                    D960k

**Example:**

BB:W3GP:MST1:HSUP:DPCC:E:FRC:ORAT D2X1920K

**Manual operation:** See "[Overall Symbol Rate](#)" on page 199

---

**[[:SOURce<hw>]:BB:W3GPp:MSTation<st>[:HSUPa]:DPCC:h:E:FRC:PAYBits?**

The command queries the payload of the information bit. This value determines the number of transport layer bits sent in each HARQ process.

**Return values:**

<PayBits>                    integer

**Example:**

SOUR:BB:W3GP:MST1:HSUP:DPCC:E:FRC:PAYB?  
Queries the payload of the information bit.  
Response: 2706

**Usage:**                    Query only

**Manual operation:** See "[Information Bit Payload \(Ninf\)](#)" on page 201



---

**[ :SOURce<hw>]:BB:W3GPp:MSTation<st>[:HSUPa]:DPCCh:E:FRC:STATe**  
 <State>

The command activates or deactivates the FRC state for the E-DPCCH channels.

**Parameters:**

<State>                    ON | OFF  
 \*RST:                    0

**Example:**                SOUR:BB:W3GP:MST1:HSUP:DPCC:E:FRC:STAT ON  
 activates the FRC state for the E-DPCCH channels.

**Manual operation:**    See "[State \(HSUPA FRC\)](#)" on page 197

---

**[ :SOURce<hw>]:BB:W3GPp:MSTation<st>[:HSUPa]:DPCCh:E:FRC:TBS:INDex**  
 <Index>

Selects the Transport Block Size Index (E-TFCI) for the corresponding table, as described in 3GPP TS 25.321, Annex B.

The value range of this parameter depends on the selected Transport Block Size Table ([\[:SOURce<hw>\]:BB:W3GPp:MSTation<st>\[:HSUPa\]:DPCCh:E:FRC:TBS:TABLE](#)).

**Parameters:**

<Index>                    integer  
 Range:                    0 to max  
 \*RST:                    41

**Example:**                BB:W3GP:MST:HSUP:DPCC:E:FRC:TBS:TABLE TAB0TTI10  
 sets the transport block size table  
 BB:W3GP:MST:HSUP:DPCC:E:FRC:TBS:INX 127  
 sets the transport block size index.

**Manual operation:**    See "[Transport Block Size Index \(E-TFCI\)](#)" on page 201

---

**[ :SOURce<hw>]:BB:W3GPp:MSTation<st>[:HSUPa]:DPCCh:E:FRC:TBS:TABLE**  
 <Table>

Selects the Transport Block Size Table from 3GPP TS 25.321, Annex B according to that the transport block size is configured.

The transport block size is determined also by the Transport Block Size Index ([\[:SOURce<hw>\]:BB:W3GPp:MSTation<st>\[:HSUPa\]:DPCCh:E:FRC:TBS:INDex](#)).

The allowed values for this command depend on the selected E-DCH TTI ([\[:SOURce<hw>\]:BB:W3GPp:MSTation<st>\[:HSUPa\]:DPCCh:E:FRC:TTIEdch](#)) and modulation scheme ([\[:SOURce<hw>\]:BB:W3GPp:MSTation<st>\[:HSUPa\]:DPCCh:E:FRC:MODulation](#)).

E-DCH TTI	Modulation	Transport Block Size Table	SCPI Parameter	Transport Block Size Index (E-TFCI)
2ms	BPSK	Table 0	TAB0TTI2	0 .. 127
		Table 1	TAB1TTI2	0 .. 125
	4PAM	Table 2	TAB2TTI2	0 .. 127
		Table 3	TAB3TTI2	0 .. 124
10ms	-	Table 0	TAB0TTI10	0 .. 127
		Table 1	TAB1TTI10	0 .. 120

**Parameters:**

<Table> TAB0TTI2 | TAB1TTI2 | TAB2TTI2 | TAB3TTI2 | TAB0TTI10 | TAB1TTI10  
 \*RST: TAB0TTI10

**Example:**

```
BB:W3GP:MST:HSUP:DPCC:E:FRC:ORAT D1920
sets the overall symbol rate
BB:W3GP:MST:HSUP:DPCC:E:FRC:MOD BPSK
sets the modulation
BB:W3GP:MST:HSUP:DPCC:E:FRC:TTIE 2
sets the E-DCH TTI
BB:W3GP:MST:HSUP:DPCC:E:FRC:TBS:TABL TAB0TTI2
sets the transport block size table
BB:W3GP:MST:HSUP:DPCC:E:FRC:TBS:IND 25
sets the transport block size index
```

**Manual operation:** See "[Transport Block Size Table](#)" on page 200

**[[:SOURce<hw>]:BB:W3GPp:MSTation<st>[:HSUPa]:DPCC:h:E:FRC:TTIBits?**

The command queries the number of physical bits sent in each HARQ process.

**Return values:**

<TtiBits> float

**Example:**

```
BB:W3GP:MST1:HSUP:DPCC:E:FRC:TTIB?
queries the number of physical bits sent in each HARQ process.
```

**Usage:**

Query only

**[[:SOURce<hw>]:BB:W3GPp:MSTation<st>[:HSUPa]:DPCC:h:E:FRC:TTIEdch  
 <Ttiedch>**

Sets the TTI size (Transmission Time Interval).

**Parameters:**

<Ttiedch> 2ms | 10ms  
 \*RST: 2ms

**Example:** `BB:W3GP:MST1:HSUP:DPCC:E:FRC:TIE 2ms`  
sets the TTI.

**Manual operation:** See "[E-DCH TTI](#)" on page 200

**[:SOURCE<hw>]:BB:W3GP:MSTation<st>[:HSUPa]:DPCC:E:FRC:UECategory?**

Queries the UE category that is minimum required for the selected FRC.

**Return values:**

<UeCategory> integer

**Example:** `BB:W3GP:MST1:HSUP:DPCC:E:FRC:UEC?`  
queries the UE category.

**Usage:** Query only

**Manual operation:** See "[UE Category](#)" on page 198

**[:SOURCE<hw>]:BB:W3GP:MSTation<st>[:HSUPa]:DPCC:E:CCODE?**

Queries the channelization code.

**Return values:**

<CCode> integer  
Range: 1 to max  
\*RST: 1

**Usage:** Query only

**Manual operation:** See "[Channelization Code](#)" on page 195

**[:SOURCE<hw>]:BB:W3GP:MSTation<st>[:HSUPa]:DPCC:E:HBIT <Hbit>**

The command activates the happy bit.

**Parameters:**

<Hbit> ON | OFF  
\*RST: ON

**Example:** `BB:W3GP:MST1:HSUP:DPCC:E:HBIT ON`  
sets the happy bit.

**Manual operation:** See "[Happy Bit](#)" on page 196

**[:SOURCE<hw>]:BB:W3GP:MSTation<st>[:HSUPa]:DPCC:E:POWER <Power>**

The command sets the power of the E-DPCCH channel.

**Parameters:**

<Power> float  
 Range: -80 dB to 0 dB  
 Increment: 0.01  
 \*RST: 0 dB

**Example:**

BB:W3GP:MST1:HSUP:DPCC:E:POW -2.5dB  
 sets the power of the E-DPCCH channel.

**Manual operation:** See ["Power"](#) on page 195

**[:SOURce<hw>]:BB:W3GPp:MSTation<st>[:HSUPa]:DPCC:h:E:RSNumber**  
 <RsNumber>

The command sets the retransmission sequence number.

**Parameters:**

<RsNumber> integer  
 Range: 0 to 3  
 \*RST: 0

**Example:**

BB:W3GP:MST1:HSUP:DPCC:E:RSN 0  
 sets the retransmission sequence number.

**Manual operation:** See ["Retransmission Sequence Number"](#) on page 195

**[:SOURce<hw>]:BB:W3GPp:MSTation<st>[:HSUPa]:DPCC:h:E:STATe** <State>

The command activates/deactivates the E-DPCCH.

**Parameters:**

<State> ON | OFF  
 \*RST: OFF

**Example:**

BB:W3GP:MST1:HSUP:DPCC:E:STAT ON  
 activates the E-DPCCH.

**Manual operation:** See ["State \(E-DPCCH\)"](#) on page 195

**[:SOURce<hw>]:BB:W3GPp:MSTation<st>[:HSUPa]:DPCC:h:E:TFCI** <Tfci>

The command sets the value for the TFCI (Transport Format Combination Indicator) field.

**Parameters:**

<Tfci> integer  
 Range: 0 to 127  
 \*RST: 0

**Example:**

BB:W3GP:MST1:HSUP:DPCC:E:TFCI 0  
 sets the value for the TFCI.

**Manual operation:** See ["E-TFCI Information"](#) on page 196

---

```
[ :SOURce<hw>]:BB:W3GPp:MSTation<st>[:HSUPa]:DPDCh:E:FCIO <Fcio>
```

The command sets the channelization code to I/O.

**Parameters:**

```
<Fcio>          ON | OFF
                *RST:      OFF
```

**Example:** `BB:W3GP:MST1:HSUP:DPDC:E:FCIO ON`  
sets the channelization code to I/O.

**Manual operation:** See "[Force Channelization Code To I/O](#)" on page 207

---

```
[ :SOURce<hw>]:BB:W3GPp:MSTation<st>[:HSUPa]:DPDCh:E:MODulation
<Modulation>
```

Sets the modulation of the E-DPDCH.

There are two possible modulation schemes specified for this channel, BPSK and 4PAM (4 Pulse-Amplitude Modulation). The latter one is available only for the following Overall Symbol Rates (`[ :SOURce<hw>]:BB:W3GPp:MSTation<st>[:HSUPa]:DPDCh:E:ORATe`):

- 2x960 ksps
- 2x1920 ksps
- 2x960 + 2x1920 ksps
- 2x960 ksps, I or Q only
- 2x1920 ksps, I or Q only
- 2x960 + 2x1920 ksps, I or Q only

**Parameters:**

```
<Modulation>   BPSK | PAM4
                *RST:      BPSK
```

**Example:** `BB:W3GP:MST1:HSUP:DPDC:E:ORAT D2x960K2x1920K`  
sets the overall symbol rate  
`BB:W3GP:MST1:HSUP:DPDC:E:MOD 4PAM`  
sets the modulation to 4PAM

**Manual operation:** See "[Modulation](#)" on page 207

---

```
[ :SOURce<hw>]:BB:W3GPp:MSTation<st>[:HSUPa]:DPDCh:E:ORATe <ORate>
```

Sets the overall symbol rate of all the E-DPDCH channels.

**Parameters:**

```
<ORate>         D15K | D30K | D60K | D120k | D240k | D480k | D960k |
                D1920k | D2X1920K | D2X960K2X1920K | D2880k | D3840k |
                D4800k | D5760k
                *RST:      D60K
```

**Example:** `BB:W3GP:MST1:HSUP:DPDC:E:ORAT D60K`

**Manual operation:** See "Overall Symbol Rate" on page 207

---

**[ :SOURce<hw>]:BB:W3GPp:MSTation<st>[:HSUPa]:DPDCh:E:STATe <State>**

The command activates or deactivates the E-DPDCHs. This always activates or deactivates all the channels.

**Parameters:**

<State> ON | OFF  
\*RST: 0

**Example:** BB:W3GP:MST1:HSUP:DPDC:E:STAT ON  
activates all the E-DPDCHs.

**Manual operation:** See "State (E-DPDCH)" on page 207

---

**[ :SOURce<hw>]:BB:W3GPp:MSTation<st>[:HSUPa]:DPDCh:E:TTIEdch <Ttiedch>**

The command sets the value for the TTI (Transmission Time Interval).

**Parameters:**

<Ttiedch> 2ms | 10ms  
\*RST: 2ms

**Example:** BB:W3GP:MST1:HSUP:DPDC:E:TTIE 2ms  
sets the value for the TTI to 2 ms.

**Manual operation:** See "E-DCH TTI" on page 212

---

**[ :SOURce<hw>]:BB:W3GPp:MSTation<st>[:HSUPa]:EDCH:TTIEdch <Ttiedch>**

Sets the value for the TTI size (Transmission Time Interval).

This command is a query only, if an UL-DTX is enabled ([ :SOURce<hw>]:BB:W3GPp:MSTation:UDTX:STATe ON) or an FRC is activated ([ :SOURce<hw>]:BB:W3GPp:MSTation<st>[:HSUPa]:DPCCh:E:FRC:STATe ON).

**Parameters:**

<Ttiedch> 2ms | 10ms  
\*RST: 2ms

**Example:** BB:W3GP:MST[:HSUPa]:EDCH:TTIE 10ms  
BB:W3GP:MST:UDTX:TTIE 2ms  
BB:W3GP:MST:UDTX:STAT ON  
BB:W3GP:MST[:HSUPa]:EDCH:TTIE?  
Response: 2ms

**Manual operation:** See "E-DCH TTI" on page 212

---

**[ :SOURce<hw>]:BB:W3GPp:MSTation<st>[:HSUPa]:EDCH:REPeat <Repeat>**

Determine the number of TTIs after that the E-DCH scheduling is repeated.

**Parameters:**

<Repeat> integer  
 Range: 1 to dynamic  
 \*RST: 1

**Example:**

```
[ :SOURce<hw>]:BB:W3GPp:MSTation<st>[:HSUPa]:
EDCH:ROWCount on page 423
```

**Manual operation:** See "E-DCH Schedule Repeats After" on page 212

```
[ :SOURce<hw>]:BB:W3GPp:MSTation<st>[:HSUPa]:EDCH:ROW<ch0>:FROM
<TtiFrom>
```

```
[ :SOURce<hw>]:BB:W3GPp:MSTation<st>[:HSUPa]:EDCH:ROW<ch0>:TO <TtiTo>
```

Determines the start/end TTI of the corresponding E-DCH burst.

**Parameters:**

<TtiTo> integer  
 Range: 0 to dynamic  
 \*RST: row index

**Example:**

```
[ :SOURce<hw>]:BB:W3GPp:MSTation<st>[:HSUPa]:
EDCH:ROWCount on page 423
```

**Manual operation:** See "E-DCH TTI To" on page 213

```
[ :SOURce<hw>]:BB:W3GPp:MSTation<st>[:HSUPa]:EDCH:ROWCount
<RowCount>
```

Sets the number of the rows in the scheduling table.

**Parameters:**

<RowCount> integer  
 Range: 1 to 32  
 \*RST: 1

**Example:**

```
E-DCH scheduling example
BB:W3GP:MST[:HSUPa]:EDCH:TTIE 2ms
BB:W3GP:MST[:HSUPa]:EDCH:ROWC 2
BB:W3GP:MST[:HSUPa]:EDCH:REP 1000
BB:W3GP:MST[:HSUPa]:EDCH:ROW0:FROM 3
BB:W3GP:MST[:HSUPa]:EDCH:ROW0:TO 6
BB:W3GP:MST[:HSUPa]:EDCH:ROW1:FROM 128
BB:W3GP:MST[:HSUPa]:EDCH:ROW0:TO 156
```

**Manual operation:** See "Number of Table Rows" on page 212

### 5.9.9 UL-DTX and uplink scheduling settings

The following are simple programming examples with the purpose to show **all** commands for this task. In real application, some of the commands can be omitted.

**Example: Configuring the UL-DTX settings**

```
*****
```

```
SOURce:BB:W3GPp:LINK UP
SOURce:BB:W3GPp:MSTation:UDTX:MODE UDTX
SOURce:BB:W3GPp:MSTation:UDTX:TTIEdch 2
SOURce:BB:W3GPp:MSTation:UDTX:OFFSet 2
SOURce:BB:W3GPp:MSTation:UDTX:ITHReshold 8
SOURce:BB:W3GPp:MSTation:UDTX:LPLength 4
SOURce:BB:W3GPp:MSTation:UDTX:CYCLe1 4
SOURce:BB:W3GPp:MSTation:UDTX:CYCLe2 8
SOURce:BB:W3GPp:MSTation:UDTX:BURSt1 1
SOURce:BB:W3GPp:MSTation:UDTX:BURSt2 1
// SOURce:BB:W3GPp:MSTation:UDTX:PREamble2?
// SOURce:BB:W3GPp:MSTation:UDTX:POSTamble1?
SOURce:BB:W3GPp:MSTation:UDTX:STATe ON
```

```
[:SOURce<hw>]:BB:W3GPp:MSTation:UDTX:MODE.....424
[:SOURce<hw>]:BB:W3GPp:MSTation:UDTX:STATe.....424
[:SOURce<hw>]:BB:W3GPp:MSTation:UDTX:TTIEdch.....425
[:SOURce<hw>]:BB:W3GPp:MSTation:UDTX:OFFSet.....425
[:SOURce<hw>]:BB:W3GPp:MSTation:UDTX:ITHReshold.....425
[:SOURce<hw>]:BB:W3GPp:MSTation:UDTX:LPLength.....425
[:SOURce<hw>]:BB:W3GPp:MSTation:UDTX:CYCLe<ch>.....426
[:SOURce<hw>]:BB:W3GPp:MSTation:UDTX:BURSt<ch>.....426
[:SOURce<hw>]:BB:W3GPp:MSTation:UDTX:PREamble<ch>?.....426
[:SOURce<hw>]:BB:W3GPp:MSTation:UDTX:POSTamble<ch>?.....427
```

---

```
[:SOURce<hw>]:BB:W3GPp:MSTation:UDTX:MODE <UldtxMode>
```

The mode is fixed to UL-DTX.

**Parameters:**

```
<UldtxMode>      UDTX
                  *RST:      UDTX
```

**Example:** See ["Example: Configuring the UL-DTX settings"](#) on page 424.

**Options:** R&S SMBVB-K83

**Manual operation:** See ["Mode"](#) on page 155

---

```
[:SOURce<hw>]:BB:W3GPp:MSTation:UDTX:STATe <State>
```

Enables/disables UL-DTX.

Enabling the UL-DTX deactivates the DPDCH and the HSUPA FRC.

**Parameters:**

```
<State>          1 | ON | 0 | OFF
                  *RST:      0
```

**Example:** See ["Example: Configuring the UL-DTX settings"](#) on page 424.



**Manual operation:** See ["UL-DTX... / User Scheduling State"](#) on page 155

---

**[:SOURCE<hw>]:BB:W3GPP:MSTation:UDTX:TTIEdch <EdchTti>**

Sets the duration of a E-DCH TTI.

**Parameters:**

<EdchTti>                    2ms | 10ms  
 Range:                    2ms to 10ms  
 \*RST:                    2ms

**Example:** see ["Example: Configuring the UL-DTX settings"](#) on page 424

**Manual operation:** See ["E-DCH TTI"](#) on page 155

---

**[:SOURCE<hw>]:BB:W3GPP:MSTation:UDTX:OFFSet <Offset>**

Sets the parameter UE\_DTX\_DRX\_Offset and determines the start offset in subframes of the first uplink DPCCH burst (after the preamble). The offset is applied only for bursts belonging to the DPCCH burst pattern; HS-DPCCH or E-DCH transmissions are not affected.

**Parameters:**

<Offset>                    integer  
 Range:                    0 to 159  
 Increment:                depends on E-DCH TTI parameter  
 \*RST:                    0

**Example:** See ["Example: Configuring the UL-DTX settings"](#) on page 424

**Manual operation:** See ["Offset"](#) on page 155

---

**[:SOURCE<hw>]:BB:W3GPP:MSTation:UDTX:ITHReshold <Threshold>**

Defines the number of consecutive E-DCH TTIs without an E-DCH transmission, after which the UE shall immediately move from UE-DTX cycle 1 to using UE-DTX cycle 2.

**Parameters:**

<Threshold>                1 | 4 | 8 | 16 | 32 | 64 | 128 | 256  
 \*RST:                    16

**Example:** see ["Example: Configuring the UL-DTX settings"](#) on page 424

**Manual operation:** See ["Inactivity Threshold for Cycle 2"](#) on page 156

---

**[:SOURCE<hw>]:BB:W3GPP:MSTation:UDTX:LPLength <LongPreamble>**

Determines the length in slots of the preamble associated with the UE-DTX cycle 2.

**Parameters:**

<LongPreamble>            2 | 4 | 15  
 \*RST:                    2

**Example:** see ["Example: Configuring the UL-DTX settings"](#) on page 424

**Manual operation:** See ["Long Preamble Length"](#) on page 156

**[ :SOURce<hw>]:BB:W3GPP:MSTation:UDTX:CYCLE<ch>** <DtxCycle>

Sets the offset in subframe between two consecutive DPCCH bursts within the corresponding UE-DTX cycle, i.e. determines how often the DPCCH bursts are transmitted.

The UE-DTX cycle 2 is an integer multiple of the UE-DTX cycle 1, i.e. has less frequent DPCCH transmission instants.

**Note:** The allowed values depend on the selected E-DCH TTI.

**Suffix:**

<ch> 1|2  
UL-DTX cycle 1 or 2

**Parameters:**

<DtxCycle> 1 | 4 | 5 | 8 | 10 | 16 | 20 | 32 | 40 | 64 | 80 | 128 | 160  
\*RST: 5

**Example:** see ["Example: Configuring the UL-DTX settings"](#) on page 424

**Manual operation:** See ["DTX Cycle 1 / DTX Cycle 2"](#) on page 156

**[ :SOURce<hw>]:BB:W3GPP:MSTation:UDTX:BURSt<ch>** <BurstLength>

Determines the uplink DPCCH burst length in subframes without the preamble and postamble, when the corresponding UE-DTX cycle is applied.

**Suffix:**

<ch> 1|2  
UL-DTX cycle 1 or 2

**Parameters:**

<BurstLength> 1 | 2 | 5  
\*RST: 1

**Example:** See ["Example: Configuring the UL-DTX settings"](#) on page 424

**Manual operation:** See ["DPCCH Burst Length 1 / DPCCH Burst Length 2"](#) on page 157

**[ :SOURce<hw>]:BB:W3GPP:MSTation:UDTX:PREAmble<ch>?**

Queries the preamble length in slots, when the corresponding UE-DTX cycle is applied.

The preamble length is fixed to 2 slots.

**Suffix:**

<ch> 1|2  
UL-DTX cycle 1 or 2

**Return values:**

<Preamble> integer  
 Range: 2 to 2  
 \*RST: 2

**Example:** see ["Example: Configuring the UL-DTX settings"](#) on page 424

**Usage:** Query only

**Manual operation:** See ["Preamble Length 1 / Preamble Length 2"](#) on page 157

**[:SOURce<hw>]:BB:W3GPP:MSTation:UDTX:POSTamble<ch>?**

Queries the postamble length in slots, when the corresponding UE-DTX cycle is applied.

The postamble length is fixed to 1 slot.

**Suffix:**

<ch> 1|2  
 UL-DTX cycle 1 or 2

**Return values:**

<PostAmble> integer  
 Range: 1 to 1

**Example:** see ["Example: Configuring the UL-DTX settings"](#) on page 424

**Usage:** Query only

**Manual operation:** See ["Postamble Length 1 / Postamble Length 2"](#) on page 157

## 5.9.10 Dynamic power control settings

### Example: Configuring the Dynamic Power Control Settings

The following is a simple programming example with the purpose to show **all** commands for this task. In real application, some of the commands can be omitted.

```
SOURce:BB:W3GPP:MSTation:ENHanced:DPDCh:DPControl:DIRection UP
// selects direction up, a high level of the control signals
// leads to an increase of the channel power
SOURce:BB:W3GPP:MSTation:ENHanced:DPDCh:DPControl:STEP 1 dB
// selects a step width of 1 dB.
// A high level of the control signal leads to
// an increase of 1 dB of the channel power,
// a low level to a decrease of 1 dB.
SOURce:BB:W3GPP:MSTation:ENHanced:DPDCh:DPControl:RANGE:DOWN 10 dB
// selects a dynamic range of 10 dB for ranging up the channel power
SOURce:BB:W3GPP:MSTation:ENHanced:DPDCh:DPControl:RANGE:UP 50 dB
// selects a dynamic range of 50 dB for ranging up the channel power
// The overall increase and decrease of channel power,
```

```
// i.e. the dynamic range is limited to 60 dB
SOURCE:BB:W3GPP:MSTation:ENHanced:DPDCh:DPControl:MODE TPC
// selects the source of the power control signal
SOURCE:BB:W3GPP:MSTation:ENHanced:DPDCh:DPControl:STATE ON
// activates Dynamic Power Control for the enhanced channels of UE1
SOURCE:BB:W3GPP:MSTation:ENHanced:DPDCh:DPControl:POWer?
// queries the deviation of the channel power (delta POW)
// from the set power start value of the DPDCH
SOURCE:BB:W3GPP:MSTation:ENHanced:DPDCh:DPControl:AOUE ON

[:SOURCE<hw>]:BB:W3GPP:MSTation[:ENHanced:DPDCh]:DPControl:ASSignment..... 428
[:SOURCE<hw>]:BB:W3GPP:MSTation[:ENHanced:DPDCh]:DPControl:DIRection..... 428
[:SOURCE<hw>]:BB:W3GPP:MSTation[:ENHanced:DPDCh]:DPControl:MODE..... 429
[:SOURCE<hw>]:BB:W3GPP:MSTation[:ENHanced:DPDCh]:DPControl[:POWer]?..... 429
[:SOURCE<hw>]:BB:W3GPP:MSTation[:ENHanced:DPDCh]:DPControl:RANGE:DOWN..... 429
[:SOURCE<hw>]:BB:W3GPP:MSTation[:ENHanced:DPDCh]:DPControl:RANGE:UP..... 429
[:SOURCE<hw>]:BB:W3GPP:MSTation[:ENHanced:DPDCh]:DPControl:STATE..... 430
[:SOURCE<hw>]:BB:W3GPP:MSTation[:ENHanced:DPDCh]:DPControl:STEP:MANual..... 430
[:SOURCE<hw>]:BB:W3GPP:MSTation[:ENHanced:DPDCh]:DPControl:STEP[:EXternal]..... 430
```

---

**[:SOURCE<hw>]:BB:W3GPP:MSTation[:ENHanced:DPDCh]:DPControl:  
ASSignment <ASSignment>**

Enabled for UL-DTX mode only ([:SOURCE<hw>]:BB:W3GPP:MSTation:UDTX:STATE ON).

The power control recognizes the UL-DPCCH gaps according to 3GPP TS 25.214. Some of the TPC commands sent to the instrument over the external line or by the TPC pattern are ignored, whereas others are summed up and applied later. The processing of the TPC commands depends only on whether the BS sends the TPC bits on the F-DPCH with slot format 0/ slot format 9 or not.

**Parameters:**

<ASSignment>      NORMAl | FDPCh  
\*RST:              NORMAl

**Example:**

```
BB:W3GP:MST1:UDTX:STAT ON
BB:W3GP:MST:DPC:ASS FDPCh
```

**Manual operation:** See "[Assignment Mode for UL-DTX](#)" on page 159

---

**[:SOURCE<hw>]:BB:W3GPP:MSTation[:ENHanced:DPDCh]:DPControl:DIRection  
<Direction>**

The command selects the Dynamic Power Control direction. The selected direction determines if the channel power is increased (UP) or decreased (DOWN) by control signal with high level.

**Parameters:**

<Direction>        UP | DOWN  
\*RST:              UP

**Example:** see [Example"Configuring the Dynamic Power Control Settings"](#) on page 427

**Manual operation:** See ["Direction"](#) on page 158

**[ :SOURce<hw>]:BB:W3GPP:MSTation[:ENHanced:DPDCh]:DPControl:MODE**  
 <Mode>

Determines the source of the control signal.

**Parameters:**

<Mode> TPC | MANual  
 \*RST: EXTernal

**Example:** See [Example"Configuring the Dynamic Power Control Settings"](#) on page 427.

**Manual operation:** See ["Mode"](#) on page 158

**[ :SOURce<hw>]:BB:W3GPP:MSTation[:ENHanced:DPDCh]:DPControl[:POWER]?**

The command queries the deviation of the channel power (delta POW) from the set power start value of the DPDCH.

**Return values:**

<Power> float  
 Range: -60 to 60  
 Increment: 0.01  
 \*RST: 0

**Example:** see [Example"Configuring the Dynamic Power Control Settings"](#) on page 427

**Usage:** Query only

**Manual operation:** See ["Power Control Graph"](#) on page 159

**[ :SOURce<hw>]:BB:W3GPP:MSTation[:ENHanced:DPDCh]:DPControl:RANGE:**  
 DOWN <Down>

**[ :SOURce<hw>]:BB:W3GPP:MSTation[:ENHanced:DPDCh]:DPControl:RANGE:**  
 UP <Up>

The command selects the dynamic range for ranging up the channel power.

**Parameters:**

<Up> float  
 Range: 0 to 60  
 Increment: 0.01  
 \*RST: 10  
 Default unit: dB

**Example:** `BB:W3GP:MST:ENH:DPDC:DPC:RANG:UP 20dB`  
selects a dynamic range of 20 dB for ranging up the channel power.

**Manual operation:** See ["Up Range / Down Range"](#) on page 159

**[:SOURce<hw>]:BB:W3GPp:MSTation[:ENHanced:DPDCh]:DPControl:STATe**  
**<State>**

Activates/deactivates Dynamic Power Control.

**Parameters:**

<State> 1 | ON | 0 | OFF  
\*RST: 0

**Example:** See [Example"Configuring the Dynamic Power Control Settings"](#) on page 427.

**Manual operation:** See ["Dynamic Power Control State"](#) on page 158

**[:SOURce<hw>]:BB:W3GPp:MSTation[:ENHanced:DPDCh]:DPControl:STEP:**  
**MANual <Manual>**

Sets the control signal for manual mode of Dynamic Power Control.

**Parameters:**

<Manual> MAN0 | MAN1  
\*RST: MAN0

**Example:** `BB:W3GP:MST:ENH:DPDC:DPC:STAT ON`  
`BB:W3GP:MST:ENH:DPDC:DPC:MODE MAN`  
`BB:W3GP:MST:ENH:DPDC:DPC:STEP:MAN MAN0`

**Manual operation:** See ["Mode"](#) on page 158

**[:SOURce<hw>]:BB:W3GPp:MSTation[:ENHanced:DPDCh]:DPControl:STEP[:**  
**EXTernal] <External>**

This command sets step width by which – with Dynamic Power Control being switched on - the channel power of the enhanced channels is increased or decreased.

**Parameters:**

<External> float  
Range: 0.5 to 6  
Increment: 0.01  
\*RST: 1  
Default unit: dB

**Example:** see [Example"Configuring the Dynamic Power Control Settings"](#) on page 427

**Manual operation:** See ["Power Step"](#) on page 158

## 5.10 Enhanced channels of the user equipment

The `SOURce:BB:W3GPp:MSStation:ENHanced` subsystem contains the commands for setting the enhanced channels of user equipment 1 (UE1).

The commands of this system only take effect when the 3GPP FDD standard is activated, the uplink transmission direction is selected and user equipment 1 is enabled:

- `SOURce:BB:W3GPp:STATe ON`
- `SOURce:BB:W3GPp:LINK UP`
- `SOURce:BB:W3GPp:MSStation1:STATe ON`

### **TCHannel**<di>

The transport channel designations for remote control are `TCHannel0` for DCCH, `TCHannel1` to `TCHannel6` for DTCH1 to DTCH6.

<code>[SOURce&lt;hw&gt;]:BB:W3GPp:MSStation:ENHanced:DPDCh:BPFRame?</code> .....	431
<code>[SOURce&lt;hw&gt;]:BB:W3GPp:MSStation:ENHanced:DPDCh:CCODing:STATe</code> .....	432
<code>[SOURce&lt;hw&gt;]:BB:W3GPp:MSStation:ENHanced:DPDCh:CCODing:TYPE</code> .....	432
<code>[SOURce&lt;hw&gt;]:BB:W3GPp:MSStation:ENHanced:DPDCh:CCODing:USER:CATalog?</code> .....	433
<code>[SOURce&lt;hw&gt;]:BB:W3GPp:MSStation:ENHanced:DPDCh:CCODing:USER:DELete</code> .....	433
<code>[SOURce&lt;hw&gt;]:BB:W3GPp:MSStation:ENHanced:DPDCh:CCODing:USER:LOAD</code> .....	434
<code>[SOURce&lt;hw&gt;]:BB:W3GPp:MSStation:ENHanced:DPDCh:CCODing:USER:STORe</code> .....	434
<code>[SOURce&lt;hw&gt;]:BB:W3GPp:MSStation:ENHanced:DPDCh:DERRor:BIT:LAYer</code> .....	435
<code>[SOURce&lt;hw&gt;]:BB:W3GPp:MSStation:ENHanced:DPDCh:DERRor:BIT:RATE</code> .....	435
<code>[SOURce&lt;hw&gt;]:BB:W3GPp:MSStation:ENHanced:DPDCh:DERRor:BIT:STATe</code> .....	435
<code>[SOURce&lt;hw&gt;]:BB:W3GPp:MSStation:ENHanced:DPDCh:DERRor:BLOCK:RATE</code> .....	436
<code>[SOURce&lt;hw&gt;]:BB:W3GPp:MSStation:ENHanced:DPDCh:DERRor[BLOCK]:STATe</code> .....	436
<code>[SOURce&lt;hw&gt;]:BB:W3GPp:MSStation:ENHanced:DPDCh:INTerleaver2</code> .....	436
<code>[SOURce&lt;hw&gt;]:BB:W3GPp:MSStation:ENHanced:DPDCh:ORATe</code> .....	437
<code>[SOURce&lt;hw&gt;]:BB:W3GPp:MSStation:ENHanced:DPDCh:STATe</code> .....	437
<code>[SOURce&lt;hw&gt;]:BB:W3GPp:MSStation:ENHanced:DPDCh:TCHannel&lt;di0&gt;:RMATtribute</code> .....	437
<code>[SOURce&lt;hw&gt;]:BB:W3GPp:MSStation:ENHanced:DPDCh:TCHannel&lt;di0&gt;:STATe</code> .....	438
<code>[SOURce&lt;hw&gt;]:BB:W3GPp:MSStation:ENHanced:DPDCh:TCHannel&lt;di0&gt;:TBCount</code> .....	438
<code>[SOURce&lt;hw&gt;]:BB:W3GPp:MSStation:ENHanced:DPDCh:TCHannel&lt;di0&gt;:TBSize</code> .....	438
<code>[SOURce&lt;hw&gt;]:BB:W3GPp:MSStation:ENHanced:DPDCh:TCHannel&lt;di0&gt;:TTINterval</code> .....	439
<code>[SOURce&lt;hw&gt;]:BB:W3GPp:MSStation:ENHanced:DPDCh:TCHannel&lt;di0&gt;:CRCSize</code> .....	439
<code>[SOURce&lt;hw&gt;]:BB:W3GPp:MSStation:ENHanced:DPDCh:TCHannel&lt;di0&gt;:DATA</code> .....	439
<code>[SOURce&lt;hw&gt;]:BB:W3GPp:MSStation:ENHanced:DPDCh:TCHannel&lt;di0&gt;:DATA:DSElect</code> ..	440
<code>[SOURce&lt;hw&gt;]:BB:W3GPp:MSStation:ENHanced:DPDCh:TCHannel&lt;di0&gt;:DATA:PATTern</code> ..	440
<code>[SOURce&lt;hw&gt;]:BB:W3GPp:MSStation:ENHanced:DPDCh:TCHannel&lt;di0&gt;:EPRotectio</code> .....	441
<code>[SOURce&lt;hw&gt;]:BB:W3GPp:MSStation:ENHanced:DPDCh:TCHannel&lt;di0&gt;:INTerleaver</code> .....	441
<code>[SOURce&lt;hw&gt;]:BB:W3GPp:MSStation:ENHanced:PCPCh:CCODing:STATe</code> .....	441
<code>[SOURce&lt;hw&gt;]:BB:W3GPp:MSStation:ENHanced:PCPCh:CCODing:TYPE</code> .....	442
<code>[SOURce&lt;hw&gt;]:BB:W3GPp:MSStation&lt;st&gt;:ENHanced:PRACH:CCODing:STATe</code> .....	442
<code>[SOURce&lt;hw&gt;]:BB:W3GPp:MSStation&lt;st&gt;:ENHanced:PRACH:CCODing:TYPE</code> .....	442

### **[SOURce<hw>]:BB:W3GPp:MSStation:ENHanced:DPDCh:BPFRame?**

The command queries the number of data bits in the DPDCH component of the frame at the physical layer. The number of data bits depends on the overall symbol rate.

**Return values:**

<BpFrame> integer  
Range: 150 to 9600

**Example:**

BB:W3GP:MST:ENH:DPDC:BPFR?  
queries the number of data bits.  
Response: 300  
the number of data bits is 300.

**Usage:**

Query only

**Manual operation:** See "[Bits per Frame \(DPDCH\)](#)" on page 217

**[ :SOURce<hw>]:BB:W3GPp:MSTation:ENHanced:DPDCh:CCODing:STATE**  
<State>

The command activates or deactivates channel coding for the enhanced channels.

When channel coding is activated, the overall symbol rate ([\[:SOURce<hw>\]:BB:W3GPp:MSTation:ENHanced:DPDCh:ORATe](#)) is set to the value predetermined by the selected channel coding type ([\[:SOURce<hw>\]:BB:W3GPp:MSTation:ENHanced:DPDCh:CCODing:TYPE](#)).

**Parameters:**

<State> 1 | ON | 0 | OFF  
\*RST: 0

**Example:**

BB:W3GP:MST:ENH:DPDC:CCOD:TYPE M12K2  
selects channel coding type RMC 12.2 kbps.  
BB:W3GP:MST:ENH:DPDC:CCOD:STAT ON  
activates channel coding.

**Manual operation:** See "[Channel Coding State](#)" on page 216

**[ :SOURce<hw>]:BB:W3GPp:MSTation:ENHanced:DPDCh:CCODing:TYPE** <Type>

The command selects the channel coding scheme in accordance with the 3GPP specification. The channel coding scheme selected predetermines the overall symbol rate.

When channel coding is activated ([\[:SOURce<hw>\]:BB:W3GPp:MSTation:ENHanced:DPDCh:CCODing:STATE](#)) the overall symbol rate ([\[:SOURce<hw>\]:BB:W3GPp:MSTation:ENHanced:DPDCh:ORATe](#)) is set to the value predetermined by the selected channel coding type.

**Parameters:**

<Type> M12K2 | M64K | M144k | M384k | AMR

**M12K2**

Measurement channel with an input data bit rate of 12.2 ksps.

**M64K**

Measurement channel with an input data bit rate of 64 ksps.

**M144K**

Measurement channel with an input data bit rate of 144 ksps.



**M384K**

Measurement channel with an input data bit rate of 384 kbps.

**AMR**

Channel coding for the AMR Coder (coding a voice channel).

**USER**

This parameter cannot be set. USER is returned whenever a user-defined channel coding is active, that is to say, after a channel coding parameter has been changed or a user coding file has been loaded. The file is loaded by the command `[ :SOURce<hw> ] :BB:W3GPp:MSTation:ENHanced:DPDCh:CCODing:USER:LOAD`.

\*RST: M12K2

**Example:**

`BB:W3GP:MST:ENH:DPDC:CCOD:TYPE M144K`  
selects channel coding scheme RMC 144 kbps.

**Manual operation:** See "[Coding Type](#)" on page 216

**[ :SOURce<hw> ] :BB:W3GPp:MSTation:ENHanced:DPDCh:CCODing:USER:CATalog?**

The command queries existing files with stored user channel codings.

The files are stored with the fixed file extensions `*.3g_ccod_ul` in a directory of the user's choice. The directory applicable to the commands is defined with the command `MMEMoRY:CDIR`.

**Return values:**

<Catalog> string

**Example:**

`MME:CDIR '/var/user/temp/CcodDpchUser'`  
selects the directory for the user channel coding files.  
`BB:W3GP:MST:ENH:DPDC:CCOD:USER:CAT?`  
queries the existing files with user coding.  
Response: 'user\_cc1'  
there is one file with user coding.

**Usage:** Query only

**Manual operation:** See "[User Coding ...](#)" on page 217

**[ :SOURce<hw> ] :BB:W3GPp:MSTation:ENHanced:DPDCh:CCODing:USER:DElete <Filename>**

The command deletes the specified files with stored user channel codings.

The files are stored with the fixed file extensions `*.3g_ccod_ul` in a directory of the user's choice. The directory applicable to the commands is defined with the command `MMEMoRY:CDIR`. To access the files in this directory, you only have to give the file name, without the path and the file extension.

The command triggers an event and therefore has no query form and no \*RST value.

**Setting parameters:****<Filename>** string**Example:**

MMEM:CDIR '/var/user/temp/CcodDpchUser'  
 selects the directory for the user channel coding files.  
 BB:W3GP:MST:ENH:DPDC:CCOD:USER:DEL 'user\_cc1'  
 deletes the specified file with user coding.

**Usage:**

Setting only

**Manual operation:** See "User Coding ..." on page 217

**[:SOURCE<hw>]:BB:W3GPP:MSTation:ENHanced:DPDCh:CCODing:USER:LOAD**  
**<Filename>**

The command loads the specified files with stored user channel codings.

The files are stored with the fixed file extensions \*.3g\_ccod\_u1 in a directory of the user's choice. The directory applicable to the commands is defined with the command MMEMory:CDIR. To access the files in this directory, you only have to give the file name, without the path and the file extension.

**Setting parameters:****<Filename>** string**Example:**

MMEM:CDIR '/var/user/temp/CcodDpchUser'  
 selects the directory for the user channel coding files.  
 BB:W3GP:MST:ENH:DPDC:CCOD:USER:LOAD 'user\_cc1'  
 loads the specified file with user coding.

**Usage:**

Setting only

**Manual operation:** See "User Coding ..." on page 217

**[:SOURCE<hw>]:BB:W3GPP:MSTation:ENHanced:DPDCh:CCODing:USER:**  
**STORE <Filename>**

The command saves the current settings for channel coding as user channel coding in the specified file.

The files are stored with the fixed file extensions \*.3g\_ccod\_u1 in a directory of the user's choice. The directory in which the file is stored is defined with the command MMEMory:CDIR. To store the files in this directory, you only have to give the file name, without the path and the file extension.

**Setting parameters:****<Filename>** string**Example:**

MMEM:CDIR '/var/user/temp/CcodDpchUser'  
 selects the directory for the user channel coding files.  
 BB:W3GP:MST:ENH:DPDC:CCOD:USER:STOR 'user\_cc1'  
 saves the current channel coding setting in file user\_cc1 in  
 directory /var/user/temp/CcodDpchUser.

**Usage:**

Setting only

**Manual operation:** See ["User Coding ..."](#) on page 217

---

**[:SOURce<hw>]:BB:W3GPp:MSTation:ENHanced:DPDCh:DERRor:BIT:LAYer**  
<Layer>

The command selects the layer at which bit errors are inserted.

**Parameters:**

<Layer>

TRANsport | PHYSical

**TRANsport**

Transport Layer (Layer 2). This layer is only available when channel coding is active.

**PHYSical**

Physical layer (Layer 1)

\*RST: PHYSical

**Example:**

BB:W3GP:MST:ENH:DPDC:DERR:BIT:LAY PHYS  
selects layer 1 for entering bit errors.

**Manual operation:** See ["Insert Errors On"](#) on page 221

---

**[:SOURce<hw>]:BB:W3GPp:MSTation:ENHanced:DPDCh:DERRor:BIT:RATE**  
<Rate>

Sets the bit error rate.

**Parameters:**

<Rate>

float

Range: 1E-7 to 0.5

Increment: 1E-7

\*RST: 0.001

**Example:**

BB:W3GP:MST:ENH:DPDC:DERR:BIT:RATE 1E-2  
sets a bit error rate of 0.01.

**Manual operation:** See ["Bit Error Rate TCH1"](#) on page 221

---

**[:SOURce<hw>]:BB:W3GPp:MSTation:ENHanced:DPDCh:DERRor:BIT:STATE**  
<State>

The command activates or deactivates bit error generation.

Bit errors are inserted into the data fields of the enhanced channels. When channel coding is active, it is possible to select the layer in which the errors are inserted (physical or transport layer). When the data source is read out, individual bits are deliberately inverted at random points in the data bit stream at the specified error rate in order to simulate an invalid signal.

**Parameters:**

<State>

1 | ON | 0 | OFF

\*RST: 0

**Example:** `BB:W3GP:MST:ENH:DPDC:DERR:BIT:RATE 1E-2`  
sets a bit error rate of 0.01.  
`BB:W3GP:MST:ENH:DPDC:DERR:BIT:LAY PHYS`  
selects layer 1 for entering bit errors.  
`BB:W3GP:MST:ENH:DPDC:DERR:BIT:STAT ON`  
activates bit error generation.

**Manual operation:** See ["Bit Error State"](#) on page 221  
See ["Block Error State"](#) on page 222

**[[:SOURce<hw>]:BB:W3GPp:MSTation:ENHanced:DPDCh:DERRor:BLOCK:RATE**  
**<Rate>**

Sets the block error rate.

**Parameters:**

**<Rate>** float  
Range: 1E-4 to 0.5  
Increment: 1E-4  
\*RST: 0.1

**Example:** `BB:W3GP:MST:ENH:DPDC:DERR:BLOC:RATE 1E-2`  
sets the block error rate to 0.01.

**Manual operation:** See ["Block Error Rate"](#) on page 222

**[[:SOURce<hw>]:BB:W3GPp:MSTation:ENHanced:DPDCh:DERRor[:BLOCK]:**  
**STATE <State>**

The command activates or deactivates block error generation. Block error generation is only possible when channel coding is activated.

During block error generation, the CRC checksum is determined and then the last bit is inverted at the specified error probability in order to simulate a defective signal.

**Parameters:**

**<State>** ON | OFF  
\*RST: OFF

**Example:** `BB:W3GP:MST:ENH:DPDC:CCOD:STAT ON`  
activates channel coding.  
`BB:W3GP:MST:ENH:DPDC:DERR:BLOC:RATE 10E-2`  
sets the block error rate to 0.1.  
`BB:W3GP:MST:ENH:DPDC:DERR:BLOC:STAT ON`  
activates block error generation.

**[[:SOURce<hw>]:BB:W3GPp:MSTation:ENHanced:DPDCh:INTerleaver2**  
**<Interleaver2>**

The command activates or deactivates channel coding interleaver state 2 for all the transport channels.

Interleaver state 1 can be activated and deactivated for each channel individually (`[ :SOURce<hw>]:BB:W3GPp:MSTation:ENHanced:DPDCh:TCHannel<di0>:INTerleaver`).

**Note:** The interleaver states do not cause the symbol rate to change

**Parameters:**

<Interleaver2> 1 | ON | 0 | OFF  
\*RST: 1

**Example:**

BB:W3GP:MST:ENH:DPDC:INT2 OFF  
deactivates channel coding interleaver state 2 for all the transport channels.

**Manual operation:** See "[Interleaver 2 State](#)" on page 220

`[ :SOURce<hw>]:BB:W3GPp:MSTation:ENHanced:DPDCh:ORATe <ORate>`

The command queries the overall symbol rate (Overall Symbol Rate) of the enhanced channels. The value is set with the command `[ :SOURce<hw>]:BB:W3GPp:MSTation<st>:DPDCh:ORATe`. This setting also defines the number of active channels, their symbol rates and channelization codes.

**Parameters:**

<ORate> D15K | D30K | D60K | D120k | D240k | D480k | D960k |  
D1920k | D2880k | D3840k | D4800k | D5760k  
\*RST: D60K

**Example:**

BB:W3GP:MST:ENH:DPDC:ORAT?  
queries the overall symbol rate of the DPDCH of user equipment 1.

**Manual operation:** See "[Overall Symbol Rate](#)" on page 217

`[ :SOURce<hw>]:BB:W3GPp:MSTation:ENHanced:DPDCh:STATe <State>`

Queries the enhanced state of the station.

**Parameters:**

<State> 1 | ON | 0 | OFF  
\*RST: 1

**Example:**

BB:W3GP:MST1:ENH:DPDC:STAT?

**Manual operation:** See "[Enhanced Channels State](#)" on page 214

`[ :SOURce<hw>]:BB:W3GPp:MSTation:ENHanced:DPDCh:TCHannel<di0>:RMAtribute <RmAttribute>`

Sets data rate matching.

**Parameters:**

<RmAttribute> integer  
 Range: 1 to 1024  
 \*RST: 1

**Example:**

BB:W3GP:MST:ENH:DPDC:TCH:RMAT 1024  
 sets rate matching to 1024 for DTCH1.

**Manual operation:** See ["Rate Matching Attribute"](#) on page 220

**[:SOURCE<hw>]:BB:W3GPp:MSTation:ENHanced:DPDCh:TCHannel<di0>:STATe**  
 <State>

The command activates/deactivates the selected transport channel.

**Parameters:**

<State> 1 | ON | 0 | OFF  
 \*RST: 0

**Example:**

BB:W3GP:MST:ENH:DPDC:TCH1:STAT  
 activates DTCH1.

**Manual operation:** See ["Transport Channel State"](#) on page 218

**[:SOURCE<hw>]:BB:W3GPp:MSTation:ENHanced:DPDCh:TCHannel<di0>:**  
**TBCount <TbCount>**

The command sets the transport block count.

**Parameters:**

<TbCount> integer  
 Range: 1 to 16  
 \*RST: 1

**Example:**

BB:W3GP:MST:ENH:DPDC:TCH2:TBC 4  
 activates 4 transport blocks for DTCH1.

**Manual operation:** See ["Number of Transport Blocks"](#) on page 219

**[:SOURCE<hw>]:BB:W3GPp:MSTation:ENHanced:DPDCh:TCHannel<di0>:TBSize**  
 <TbSize>

Sets the size of the data blocks.

**Parameters:**

<TbSize> integer

**Example:**

BB:W3GP:MST:ENH:DPDC:TCH2:TBS 1024  
 sets the length of the transport blocks for DTCH2 to 1024.

**Manual operation:** See ["Transport Block Size"](#) on page 219

---

```
[ :SOURce<hw>]:BB:W3GPp:MSTation:ENHanced:DPDCh:TCHannel<di0>:
TTInterval <TtInterval>
```

Sets the number of frames into which a TCH is divided. This setting also defines the interleaver depth.

**Parameters:**

```
<TtInterval>          10MS | 20MS | 40MS
```

**Example:**

```
BB:W3GP:MST:ENH:DPDC:TCH2:TTIN 20ms
sets that the transport channel is divided into 2 frames.
```

**Manual operation:** See "[Transport Time Interval](#)" on page 219

---

```
[ :SOURce<hw>]:BB:W3GPp:MSTation:ENHanced:DPDCh:TCHannel<di0>:
CRCSize <CrcSize>
```

The command defines the CRC length for the selected transport channel. It is also possible to deactivate checksum determination.

**Parameters:**

```
<CrcSize>             NONE | 8 | 12 | 16 | 24
*RST:                 12
```

**Example:**

```
BB:W3GP:MST:ENH:DPDC:TCH:CRCS NONE
deactivates checksum determination for DTCH1.
```

**Manual operation:** See "[Size of CRC](#)" on page 220

---

```
[ :SOURce<hw>]:BB:W3GPp:MSTation:ENHanced:DPDCh:TCHannel<di0>:DATA
<Data>
```

Selects the data source for the transport channel.

**Parameters:**

```
<Data>                ZERO | ONE | PATtern | PN9 | PN11 | PN15 | PN16 | PN20 |
PN21 | PN23 | DLISt
```

**PNxx**

The pseudo-random sequence generator is used as the data source. Different random sequence lengths can be selected.

**DLISt**

A data list is used. The data list is selected with the command `[ :SOURce<hw>]:BB:W3GPp:MSTation:ENHanced:DPDCh:TCHannel<di0>:DATA:DSElect`.

**ZERO | ONE**

Internal 0 and 1 data is used.

**PATtern**

Internal data is used. The bit pattern for the data is defined by the command `[ :SOURce<hw>]:BB:W3GPp:MSTation:ENHanced:DPDCh:TCHannel<di0>:DATA:PATtern`.

```
*RST:                 PN9
```

**Example:** `BB:W3GP:MST:ENH:DPDC:TCH2:DATA PATT`  
 selects as the data source for the data fields of DTCH2 of user equipment 1, the bit pattern defined with the following command.  
`BB:W3GP:MST:ENH:DPDC:TCH2:DATA:PATT #H3F, 8`  
 defines the bit pattern.

**Manual operation:** See ["Data Source"](#) on page 218

**[:SOURCE<hw>]:BB:W3GPp:MSTation:ENHanced:DPDCh:TCHannel<di0>:DATA:  
 DSElect <DSelect>**

The command selects the data list for the enhanced channels for the DLIS selection.

The files are stored with the fixed file extensions `*.dm_iqd` in a directory of the user's choice. The directory applicable to the commands is defined with the command `MMEMory:CDIR`. To access the files in this directory, you only have to give the file name, without the path and the file extension.

**Parameters:**

<DSelect>                    string

**Example:** `BB:W3GP:MST:ENH:DPDC:TCH1:DATA DLIS`  
 selects the Data Lists data source.  
`MMEM:CDIR '/var/user/temp/IQData'`  
 selects the directory for the data lists.  
`BB:W3GP:MST:ENH:DPDC:TCH1:DATA:DSEL 'TCH1'`  
 selects the file `tch1` as the data source.

**Manual operation:** See ["Data Source"](#) on page 218

**[:SOURCE<hw>]:BB:W3GPp:MSTation:ENHanced:DPDCh:TCHannel<di0>:DATA:  
 PATtern <Pattern>, <BitCount>**

The command determines the bit pattern for the `PATtern` data source selection for transport channels.

**Parameters:**

<Pattern>                    numeric  
                               \*RST:        #H0

<BitCount>                  integer  
                               Range:        1 to 64  
                               \*RST:        1

**Example:** `BB:W3GP:MST:ENH:DPDC:TCH0:DATA:PATT #H3F, 8`  
 defines the bit pattern for DCCH.

**Manual operation:** See ["Data Source"](#) on page 218



---

```
[ :SOURce<hw>]:BB:W3GPp:MSTation:ENHanced:DPDCh:TCHannel<di0>:
  EPRotection <EProtection>
```

The command determines the error protection.

**Parameters:**

<EProtection> NONE | CON2 | CON3 | TURBo3

**NONE**

No error protection.

**TURBo3**

Turbo Coder of rate 1/3 in accordance with the 3GPP specifications.

**CON2 | CON3**

Convolution Coder of rate 1/2 or 1/3 with generator polynomials defined by 3GPP.

\*RST: CON1/3

**Example:**

```
BB:W3GP:MST:ENH:DPDC:TCH1:EPR NONE
error protection is deactivated.
```

**Manual operation:** See "[Error Protection](#)" on page 220

---

```
[ :SOURce<hw>]:BB:W3GPp:MSTation:ENHanced:DPDCh:TCHannel<di0>:
  INTerleaver <Interleaver>
```

The command activates or deactivates channel coding interleaver state 1 for the selected channel. Interleaver state 1 can be activated and deactivated for each channel individually. The channel is selected via the suffix at TCHannel.

Interleaver state 2 can only be activated or deactivated for all the channels together (`[ :SOURce<hw>]:BB:W3GPp:MSTation:ENHanced:DPDCh:INTerleaver2`).

**Parameters:**

<Interleaver> 1 | ON | 0 | OFF

\*RST: 1

**Example:**

```
BB:W3GP:MST:ENH:DPDC:TCH5:INT1 OFF
deactivates channel coding interleaver state 1 for TCH 5.
```

**Manual operation:** See "[Interleaver 1 State](#)" on page 220

---

```
[ :SOURce<hw>]:BB:W3GPp:MSTation:ENHanced:PCPCh:CCODing:STATe
  <State>
```

The command activates or deactivates channel coding for the PCPCH.

When channel coding is active, the symbol rate is limited to the range between 15 and 120 ksp. Values above this limit are automatically set to 120 ksp.

**Parameters:**

<State> ON | OFF

\*RST: 0

**Example:** `BB:W3GP:MST:ENH:PCPC:CCOD:TYPE TB168`  
selects channel coding type CPCH RMC (TB size 168 bits).  
`BB:W3GP:MST:ENH:PCPC:CCOD:STAT ON`  
activates channel coding.

**Manual operation:** See "[Channel Coding State](#)" on page 244

**[:SOURce<hw>]:BB:W3GPp:MSTation:ENHanced:PCPCh:CCODing:TYPE <Type>**

The command selects the channel coding scheme in accordance with the 3GPP specification.

**Parameters:**

<Type> TB168 | TB360  
**TB168**  
CPCH RMC (TB size 168 bits)  
**TB360**  
CPCH RMC (TB size 360 bits)  
\*RST: TB168

**Example:** `BB:W3GP:MST:ENH:PCPC:CCOD:TYPE TB168`  
selects channel coding scheme RMC 168 bits.

**Manual operation:** See "[Channel Coding Type](#)" on page 244

**[:SOURce<hw>]:BB:W3GPp:MSTation<st>:ENHanced:PRACH:CCODing:STATE <State>**

The command activates or deactivates channel coding for the PRACH.

**Parameters:**

<State> ON | OFF  
\*RST: 0

**Example:** `BB:W3GP:MST:ENH:PRAC:CCOD:TYPE TB168`  
selects channel coding type RACH RMC (TB size 168 bits).  
`BB:W3GP:MST:ENH:PRAC:CCOD:STAT ON`  
activates channel coding.

**Manual operation:** See "[Coding State](#)" on page 232

**[:SOURce<hw>]:BB:W3GPp:MSTation<st>:ENHanced:PRACH:CCODing:TYPE <Type>**

The command selects the channel coding scheme in accordance with the 3GPP specification.

**Parameters:**

<Type> TB168 | TB360 | TU168 | TU360  
**TB168**  
RACH RMC (TB size 168 bits)

**TB360**

RACH RMC (TB size 360 bits)

\*RST: TB168

**Example:**

BB:W3GP:MST:ENH:PRAC:CCOD:TYPE TB168  
selects channel coding scheme RMC 168 bits.

**Manual operation:**See "[Coding Type](#)" on page 232

# Annex

## A Reference

### Supported channel types

**Table A-1: List of supported channel types and their sequence in the 3GPP FDD channel table**

Index	Short form	Name	Function	Optional enhanced in BS1
0	P-CPICH	Primary Common Pilot Channel	<ul style="list-style-type: none"> <li>Specifies the scrambling code in the scrambling code group (2nd stage of scrambling code detection)</li> <li>Phase reference for additional downlink channels</li> <li>Reference for the signal strength</li> </ul>	no
1	S-CPICH	Secondary Common Pilot Channel		no
2	P-SCH	Primary Sync Channel	Slot synchronization	no
3	S-SCH	Secondary Sync Channel	<ul style="list-style-type: none"> <li>Frame synchronization</li> <li>Specifies the scrambling code group</li> </ul>	no
4	P-CCPCH	Primary Common Control Phys. Channel	<ul style="list-style-type: none"> <li>Transfers the system frame number (SFN)</li> <li>Timing reference for additional downlink channels</li> <li>Contains the BCH transport channel</li> </ul>	yes
5	S-CCPCH	Secondary Common Control Phys. Channel		no
6	PICH	Page Indication Channel	Transfers the paging indicator	no
7	AICH	Acquisition Indication Channel		no
8	AP-AICH	Access Preamble Acquisition Indication Channel		no
9 / 10	PDSCH	Phys. Downlink Shared Channel		no
	DL-DPCCH	Dedicated Physical Control Channel		
	HS-SCCH	High-Speed Shared Control Channel		
	E-AGCH	E-DCH Absolute Grant Channel		
	E-RGCH	E-DCH Relative Grant Channel		
	E-HICH	E-DCH Hybrid ARQ Indicator Channel		
11 - 13	DPCH	Dedicated Phys. Channel	Transfers the user data and the control information	yes

Index	Short form	Name	Function	Optional enhanced in BS1
	HS-SCCH	High-Speed Shared Control Channel		no
	HS-PDSCH (QPSK)	High Speed Physical Downlink Shared Channel (QPSK)		no
	HS-PDSCH (16 QAM)	High-Speed Physical Downlink Shared Channel (16 QAM)		no
	HS-PDSCH (64 QAM)	High-Speed Physical Downlink Shared Channel (64 QAM)		no
	HS-PDSCH (MIMO)	High Speed Physical Downlink Shared Channel (MIMO)		no
	E-AGCH	E-DCH Absolute Grant Channel		no
	E-RGCH	E-DCH Relative Grant Channel		no
	E-HICH	E-DCH Hybrid ARQ Indicator Channel		no
	F-DPCH	Fractional Dedicated Phys. Channel		no
14 - 138	DPCH	Dedicated Phys. Channel	Transfers the user data and the control information	no
	HS-SCCH	High-Speed Shared Control Channel		
	HS-PDSCH (QPSK)	High Speed Physical Downlink Shared Channel (QPSK)		
	HS-PDSCH (16 QAM)	High-Speed Physical Downlink Shared Channel (16 QAM)		
	HS-PDSCH (64 QAM)	High-Speed Physical Downlink Shared Channel (64 QAM)		
	HS-PDSCH (MIMO)	High Speed Physical Downlink Shared Channel (MIMO)		
	E-AGCH	E-DCH Absolute Grant Channel		
	E-RGCH	E-DCH Relative Grant Channel		
	E-HICH	E-DCH Hybrid ARQ Indicator Channel		
	F-DPCH	Fractional Dedicated Phys. Channel		

### Channel tables of the DPDCH and E-DPDCH

*Table A-2: Structure of the DPDCH channel table in conjunction with the overall symbol rate*

Overall Symbol Rate	DPDCH 1	DPDCH 2	DPDCH 3	DPDCH 4	DPDCH 5	DPDCH 6
I or Q branch	I	Q	I	Q	I	Q
15 ksp/s	<b>State: ON</b> <b>S-Rate: 15k</b> <b>Ch. Code: 64</b>	State: OFF	State: OFF	State: OFF	State: OFF	State: OFF
30 ksp/s	<b>State: ON</b> <b>S-Rate: 30k</b> <b>Ch. Code: 32</b>	State: OFF	State: OFF	State: OFF	State: OFF	State: OFF
60 ksp/s	<b>State: ON</b> <b>S-Rate: 60k</b> <b>Ch. Code: 16</b>	State: OFF	State: OFF	State: OFF	State: OFF	State: OFF
120 ksp/s	<b>State: ON</b> <b>S-Rate: 120k</b> <b>Ch. Code: 8</b>	State: OFF	State: OFF	State: OFF	State: OFF	State: OFF
240 ksp/s	<b>State: ON</b> <b>S-Rate: 240k</b> <b>Ch. Code: 4</b>	State: OFF	State: OFF	State: OFF	State: OFF	State: OFF
480 ksp/s	<b>State: ON</b> <b>S-Rate: 480k</b> <b>Ch. Code: 2</b>	State: OFF	State: OFF	State: OFF	State: OFF	State: OFF
960 ksp/s	<b>State: ON</b> <b>S-Rate: 960k</b> <b>Ch. Code: 1</b>	State: OFF	State: OFF	State: OFF	State: OFF	State: OFF
2 x 960 ksp/s	<b>State: ON</b> <b>S-Rate: 960k</b> <b>Ch. Code: 1</b>	<b>State: ON</b> <b>S-Rate: 960k</b> <b>Ch. Code: 1</b>	State: OFF	State: OFF	State: OFF	State: OFF
3 x 960 ksp/s	<b>State: ON</b> <b>S-Rate: 960k</b> <b>Ch. Code: 1</b>	<b>State: ON</b> <b>S-Rate: 960k</b> <b>Ch. Code: 1</b>	<b>State: ON</b> <b>S-Rate: 960k</b> <b>Ch. Code: 3</b>	State: OFF	State: OFF	State: OFF

Overall Symbol Rate	DPDCH 1	DPDCH 2	DPDCH 3	DPDCH 4	DPDCH 5	DPDCH 6
4 x 960 kbps	State: ON S-Rate: 960k Ch. Code: 1	State: ON S-Rate: 960k Ch. Code: 1	State: ON S-Rate: 960k Ch. Code: 3	State: ON S-Rate: 960k Ch. Code: 3	State: OFF	State: OFF
5 x 960 kbps	State: ON S-Rate: 960k Ch. Code: 1	State: ON S-Rate: 960k Ch. Code: 1	State: ON S-Rate: 960k Ch. Code: 3	State: ON S-Rate: 960k Ch. Code: 3	State: ON S-Rate: 960k Ch. Code: 2	State: OFF
6 x 960 kbps	State: ON S-Rate: 960k Ch. Code: 1	State: ON S-Rate: 960k Ch. Code: 1	State: ON S-Rate: 960k Ch. Code: 3	State: ON S-Rate: 960k Ch. Code: 3	State: ON S-Rate: 960k Ch. Code: 2	State: ON S-Rate: 960k Ch. Code: 2

*Table A-3: Structure of the E-DPDCH channel table in conjunction with the overall symbol rate and no DPDCH active*

Overall Symbol Rate	E-DPDCH 1	E-DPDCH 2	E-DPDCH 3	E-DPDCH 4
I or Q branch	I	Q	I	Q
15 Kbps	State: ON S-Rate: 15 k Ch. Code: 64	State: OFF	State: OFF	State: OFF
30 kbps	State: ON S-Rate: 30 k Ch. Code: 32	State: OFF	State: OFF	State: OFF
60 kbps	State: ON S-Rate: 60 k Ch. Code: 16	State: OFF	State: OFF	State: OFF
120 kbps	State: ON S-Rate: 120 k Ch. Code: 8	State: OFF	State: OFF	State: OFF
240 kbps	State: ON S-Rate: 240 k Ch. Code: 4	State: OFF	State: OFF	State: OFF
480 kbps	State: ON S-Rate: 480 k Ch. Code: 2	State: OFF	State: OFF	State: OFF
960 kbps	State: ON S-Rate: 960 k Ch. Code: 1	State: OFF	State: OFF	State: OFF

Overall Symbol Rate	E-DPDCH 1	E-DPDCH 2	E-DPDCH 3	E-DPDCH 4
I or Q branch	I	Q	I	Q
2 x 960 ksps	<b>State: ON</b> <b>S-Rate: 960 k</b> <b>Ch. Code: 1</b>	<b>State: ON</b> <b>S-Rate: 960 k</b> <b>Ch. Code: 1</b>	State: OFF	State: OFF
2 x 1920 ksps	<b>State: ON</b> <b>S-Rate: 1920 k</b> <b>Ch. Code: 1</b>	<b>State: ON</b> <b>S-Rate: 1920 k</b> <b>Ch. Code: 1</b>	State: OFF	State: OFF
2 x 960 ksps + 2 x 1920 ksps	<b>State: ON</b> <b>S-Rate: 1920 k</b> <b>Ch. Code: 1</b>	<b>State: ON</b> <b>S-Rate: 1920 k</b> <b>Ch. Code: 1</b>	<b>State: ON</b> <b>S-Rate: 960 k</b> <b>Ch. Code: 1</b>	<b>State: ON</b> <b>S-Rate: 960 k</b> <b>Ch. Code: 1</b>
2 x 960 ksps, I only	<b>State: ON</b> <b>S-Rate: 960 k</b> <b>Ch. Code: 1</b>	State: OFF	State: OFF	State: OFF
2 x 960 ksps, Q only	State: OFF	<b>State: ON</b> <b>S-Rate: 960 k</b> <b>Ch. Code: 1</b>	State: OFF	State: OFF
2 x 1920 ksps, I only	<b>State: ON</b> <b>S-Rate: 1920 k</b> <b>Ch. Code: 1</b>	State: OFF	State: OFF	State: OFF
2 x 1920 ksps, Q only	State: OFF	<b>State: ON</b> <b>S-Rate: 1920 k</b> <b>Ch. Code: 1</b>	State: OFF	State: OFF
2 x 960 ksps + 2 x 1920 ksps, I only	<b>State: ON</b> <b>S-Rate: 1920 k</b> <b>Ch. Code: 1</b>	State: OFF	<b>State: ON</b> <b>S-Rate: 960 k</b> <b>Ch. Code: 1</b>	State: OFF
2 x 960 ksps + 2 x 1920 ksps, Q only	State: OFF	<b>State: ON</b> <b>S-Rate: 1920 k</b> <b>Ch. Code: 1</b>	State: OFF	<b>State: ON</b> <b>S-Rate: 960 k</b> <b>Ch. Code: 1</b>



**Table A-4: Structure of the E-DPDCH channel table in conjunction with the overall symbol rate and one DPDCH active**

Overall Symbol Rate	E-DPDCH 1	E-DPDCH 2	E-DPDCH 3	E-DPDCH 4
<b>Active HS-DPCCH? I or Q branch</b>	<b>No Q</b>	<b>No I</b>	<b>Yes I</b>	<b>Yes Q</b>
15 ksps	<b>State: ON S-Rate: 15 k Ch. Code: 128</b>	State: OFF	<b>State: ON S-Rate: 15 k Ch. Code: 128</b>	State: OFF
30 ksps	<b>State: ON S-Rate: 30 k Ch. Code: 64</b>	State: OFF	<b>State: ON S-Rate: 30 k Ch. Code: 64</b>	State: OFF
60 ksps	<b>State: ON S-Rate: 60 k Ch. Code: 32</b>	State: OFF	<b>State: ON S-Rate: 60 k Ch. Code: 32</b>	State: OFF
120 ksps	<b>State: ON S-Rate: 120 k Ch. Code: 16</b>	State: OFF	<b>State: ON S-Rate: 120 k Ch. Code: 16</b>	State: OFF
240 ksps	<b>State: ON S-Rate: 240 k Ch. Code: 8</b>	State: OFF	<b>State: ON S-Rate: 240 k Ch. Code: 8</b>	State: OFF
480 ksps	<b>State: ON S-Rate: 480 k Ch. Code: 4</b>	State: OFF	<b>State: ON S-Rate: 480 k Ch. Code: 4</b>	State: OFF
960 ksps	<b>State: ON S-Rate: 960 k Ch. Code: 2</b>	State: OFF	<b>State: ON S-Rate: 960 k Ch. Code: 2</b>	State: OFF
2 x 960 ksps	<b>State: ON S-Rate: 960 k Ch. Code: 2</b>	<b>State: ON S-Rate: 960 k Ch. Code: 2</b>	<b>State: ON S-Rate: 960 k Ch. Code: 2</b>	<b>State: ON S-Rate: 960 k Ch. Code: 2</b>
2 x 1920 ksps	<b>State: ON S-Rate: 1920 k Ch. Code: 1</b>	<b>State: ON S-Rate: 1920 k Ch. Code: 1</b>	<b>State: ON S-Rate: 1920 k Ch. Code: 1</b>	<b>State: ON S-Rate: 1920 k Ch. Code: 1</b>
2 x 960 ksps, I only	State: OFF	<b>State: ON S-Rate: 960 k Ch. Code: 2</b>	<b>State: ON S-Rate: 960 k Ch. Code: 2</b>	State: OFF
2 x 960 ksps, Q only	<b>State: ON S-Rate: 960 k Ch. Code: 2</b>	State: OFF	State: OFF	<b>State: ON S-Rate: 960 k Ch. Code: 2</b>

Overall Symbol Rate	E-DPDCH 1	E-DPDCH 2	E-DPDCH 3	E-DPDCH 4
Active HS-DPCCH? I or Q branch	No Q	No I	Yes I	Yes Q
2 x 1920 ksps, I only	State: OFF	State: ON S-Rate: 1920 k Ch. Code: 1	State: ON S-Rate: 1920 k Ch. Code: 1	State: OFF
2 x 1920 ksps, Q only	State: ON S-Rate: 1920 k Ch. Code: 1	State: OFF	State: OFF	State: ON S-Rate: 1920 k Ch. Code: 1

# List of commands

[SOURce]:BB:W3GPp:GPP3:VERSion?	263
[SOURce<hw>]:BB:W3GPp:BSTation:ENHanced:CHANnel[<ch0>]:DPCH:CCODing:USER:CATalog?	335
[SOURce<hw>]:BB:W3GPp:BSTation:ENHanced:CHANnel[<ch0>]:DPCH:CCODing:USER:DELeTe	332
[SOURce<hw>]:BB:W3GPp:BSTation:ENHanced:CHANnel<ch0>:DPCH:CCODing:BPFRame?	332
[SOURce<hw>]:BB:W3GPp:BSTation:ENHanced:CHANnel<ch0>:DPCH:CCODing:SFORmat	333
[SOURce<hw>]:BB:W3GPp:BSTation:ENHanced:CHANnel<ch0>:DPCH:CCODing:SRATE?	333
[SOURce<hw>]:BB:W3GPp:BSTation:ENHanced:CHANnel<ch0>:DPCH:CCODing:STATe	334
[SOURce<hw>]:BB:W3GPp:BSTation:ENHanced:CHANnel<ch0>:DPCH:CCODing:TYPE	334
[SOURce<hw>]:BB:W3GPp:BSTation:ENHanced:CHANnel<ch0>:DPCH:CCODing:USER:LOAD	336
[SOURce<hw>]:BB:W3GPp:BSTation:ENHanced:CHANnel<ch0>:DPCH:CCODing:USER:STORe	336
[SOURce<hw>]:BB:W3GPp:BSTation:ENHanced:CHANnel<ch0>:DPCH:DERRor:BIT:LAYer	346
[SOURce<hw>]:BB:W3GPp:BSTation:ENHanced:CHANnel<ch0>:DPCH:DERRor:BIT:RATE	347
[SOURce<hw>]:BB:W3GPp:BSTation:ENHanced:CHANnel<ch0>:DPCH:DERRor:BIT:STATe	347
[SOURce<hw>]:BB:W3GPp:BSTation:ENHanced:CHANnel<ch0>:DPCH:DERRor:BLOCK:RATE	348
[SOURce<hw>]:BB:W3GPp:BSTation:ENHanced:CHANnel<ch0>:DPCH:DERRor:BLOCK:STATe	348
[SOURce<hw>]:BB:W3GPp:BSTation:ENHanced:CHANnel<ch0>:DPCH:DPControl:DIRectioN	344
[SOURce<hw>]:BB:W3GPp:BSTation:ENHanced:CHANnel<ch0>:DPCH:DPControl:MODE	344
[SOURce<hw>]:BB:W3GPp:BSTation:ENHanced:CHANnel<ch0>:DPCH:DPControl:RANGe:DOWN	344
[SOURce<hw>]:BB:W3GPp:BSTation:ENHanced:CHANnel<ch0>:DPCH:DPControl:STATe	345
[SOURce<hw>]:BB:W3GPp:BSTation:ENHanced:CHANnel<ch0>:DPCH:DPControl:STEP:MANual	345
[SOURce<hw>]:BB:W3GPp:BSTation:ENHanced:CHANnel<ch0>:DPCH:DPControl:STEP[EXTeRnal]	345
[SOURce<hw>]:BB:W3GPp:BSTation:ENHanced:CHANnel<ch0>:DPCH:DPControl[:POWeR]?	346
[SOURce<hw>]:BB:W3GPp:BSTation:ENHanced:CHANnel<ch0>:DPCH:INTerleaver2	337
[SOURce<hw>]:BB:W3GPp:BSTation:ENHanced:CHANnel<ch0>:DPCH:STATe	330
[SOURce<hw>]:BB:W3GPp:BSTation:ENHanced:CHANnel<ch0>:DPCH:TCHannel<di0>:CRCSize	337
[SOURce<hw>]:BB:W3GPp:BSTation:ENHanced:CHANnel<ch0>:DPCH:TCHannel<di0>:DATA	338
[SOURce<hw>]:BB:W3GPp:BSTation:ENHanced:CHANnel<ch0>:DPCH:TCHannel<di0>:DATA: DSElect	338
[SOURce<hw>]:BB:W3GPp:BSTation:ENHanced:CHANnel<ch0>:DPCH:TCHannel<di0>:DATA:PATTeRn339	339
[SOURce<hw>]:BB:W3GPp:BSTation:ENHanced:CHANnel<ch0>:DPCH:TCHannel<di0>:DTX	339
[SOURce<hw>]:BB:W3GPp:BSTation:ENHanced:CHANnel<ch0>:DPCH:TCHannel<di0>:EPRotectioN	340
[SOURce<hw>]:BB:W3GPp:BSTation:ENHanced:CHANnel<ch0>:DPCH:TCHannel<di0>:INTerleaver	340
[SOURce<hw>]:BB:W3GPp:BSTation:ENHanced:CHANnel<ch0>:DPCH:TCHannel<di0>:RMATtribute	340
[SOURce<hw>]:BB:W3GPp:BSTation:ENHanced:CHANnel<ch0>:DPCH:TCHannel<di0>:STATe	341
[SOURce<hw>]:BB:W3GPp:BSTation:ENHanced:CHANnel<ch0>:DPCH:TCHannel<di0>:TBCount	341
[SOURce<hw>]:BB:W3GPp:BSTation:ENHanced:CHANnel<ch0>:DPCH:TCHannel<di0>:TBSize	341
[SOURce<hw>]:BB:W3GPp:BSTation:ENHanced:CHANnel<ch0>:DPCH:TCHannel<di0>:TTINteRval	342
[SOURce<hw>]:BB:W3GPp:BSTation:ENHanced:PCCPch:CCODing:INTerleaver<di>	342
[SOURce<hw>]:BB:W3GPp:BSTation:ENHanced:PCCPch:CCODing:STATe	342
[SOURce<hw>]:BB:W3GPp:BSTation:ENHanced:PCCPch:CCODing:TYPE?	342
[SOURce<hw>]:BB:W3GPp:BSTation:ENHanced:PCCPch:STATe	330
[SOURce<hw>]:BB:W3GPp:BSTation:OCNS:MODE	283
[SOURce<hw>]:BB:W3GPp:BSTation:OCNS:SEED	283
[SOURce<hw>]:BB:W3GPp:BSTation:OCNS:STATe	283
[SOURce<hw>]:BB:W3GPp:BSTation:PRESet	263
[SOURce<hw>]:BB:W3GPp:BSTation[:ENHanced]:CHANnel<ch0>:HSDPa:DERRor:BIT:LAYer	348
[SOURce<hw>]:BB:W3GPp:BSTation[:ENHanced]:CHANnel<ch0>:HSDPa:DERRor:BIT:RATE	349

[.SOURCE<hw>]:BB:W3GPp:BSTation[:ENHanced]:CHANnel<ch0>:HSDPa:DERRor:BIT:STATE.....	349
[.SOURCE<hw>]:BB:W3GPp:BSTation[:ENHanced]:CHANnel<ch0>:HSDPa:DERRor:BLOCK:RATE.....	349
[.SOURCE<hw>]:BB:W3GPp:BSTation[:ENHanced]:CHANnel<ch0>:HSDPa:DERRor:BLOCK:STATE.....	350
[.SOURCE<hw>]:BB:W3GPp:BSTation<st>:CHANnel:HSDPa:HSET:PRESet.....	284
[.SOURCE<hw>]:BB:W3GPp:BSTation<st>:CHANnel:PRESet.....	284
[.SOURCE<hw>]:BB:W3GPp:BSTation<st>:CHANnel<ch0>:AICH:ASLOt.....	284
[.SOURCE<hw>]:BB:W3GPp:BSTation<st>:CHANnel<ch0>:AICH:SAPattern.....	285
[.SOURCE<hw>]:BB:W3GPp:BSTation<st>:CHANnel<ch0>:APAlch:ASLOt.....	285
[.SOURCE<hw>]:BB:W3GPp:BSTation<st>:CHANnel<ch0>:APAlch:SAPattern.....	285
[.SOURCE<hw>]:BB:W3GPp:BSTation<st>:CHANnel<ch0>:CCODE.....	286
[.SOURCE<hw>]:BB:W3GPp:BSTation<st>:CHANnel<ch0>:DATA.....	286
[.SOURCE<hw>]:BB:W3GPp:BSTation<st>:CHANnel<ch0>:DATA:DSElect.....	287
[.SOURCE<hw>]:BB:W3GPp:BSTation<st>:CHANnel<ch0>:DATA:PATtern.....	287
[.SOURCE<hw>]:BB:W3GPp:BSTation<st>:CHANnel<ch0>:DPCCh:MCODE.....	288
[.SOURCE<hw>]:BB:W3GPp:BSTation<st>:CHANnel<ch0>:DPCCh:PLENgtH.....	288
[.SOURCE<hw>]:BB:W3GPp:BSTation<st>:CHANnel<ch0>:DPCCh:POFFset:PILOt.....	289
[.SOURCE<hw>]:BB:W3GPp:BSTation<st>:CHANnel<ch0>:DPCCh:POFFset:TFCl.....	289
[.SOURCE<hw>]:BB:W3GPp:BSTation<st>:CHANnel<ch0>:DPCCh:POFFset:TPC.....	289
[.SOURCE<hw>]:BB:W3GPp:BSTation<st>:CHANnel<ch0>:DPCCh:TFCl.....	290
[.SOURCE<hw>]:BB:W3GPp:BSTation<st>:CHANnel<ch0>:DPCCh:TFCl:STATE.....	290
[.SOURCE<hw>]:BB:W3GPp:BSTation<st>:CHANnel<ch0>:DPCCh:TPC:DATA.....	290
[.SOURCE<hw>]:BB:W3GPp:BSTation<st>:CHANnel<ch0>:DPCCh:TPC:DATA:DSElect.....	291
[.SOURCE<hw>]:BB:W3GPp:BSTation<st>:CHANnel<ch0>:DPCCh:TPC:DATA:PATtern.....	292
[.SOURCE<hw>]:BB:W3GPp:BSTation<st>:CHANnel<ch0>:DPCCh:TPC:MISuse.....	292
[.SOURCE<hw>]:BB:W3GPp:BSTation<st>:CHANnel<ch0>:DPCCh:TPC:PSTep.....	292
[.SOURCE<hw>]:BB:W3GPp:BSTation<st>:CHANnel<ch0>:DPCCh:TPC:READ.....	293
[.SOURCE<hw>]:BB:W3GPp:BSTation<st>:CHANnel<ch0>:FDPCh:DPCCh:TPC:DATA.....	293
[.SOURCE<hw>]:BB:W3GPp:BSTation<st>:CHANnel<ch0>:FDPCh:DPCCh:TPC:DATA:DSElect.....	294
[.SOURCE<hw>]:BB:W3GPp:BSTation<st>:CHANnel<ch0>:FDPCh:DPCCh:TPC:DATA:PATtern.....	295
[.SOURCE<hw>]:BB:W3GPp:BSTation<st>:CHANnel<ch0>:FDPCh:DPCCh:TPC:MISuse.....	295
[.SOURCE<hw>]:BB:W3GPp:BSTation<st>:CHANnel<ch0>:FDPCh:DPCCh:TPC:PSTep.....	296
[.SOURCE<hw>]:BB:W3GPp:BSTation<st>:CHANnel<ch0>:FDPCh:DPCCh:TPC:READ.....	296
[.SOURCE<hw>]:BB:W3GPp:BSTation<st>:CHANnel<ch0>:HSDPa:BMODE[:STATE].....	297
[.SOURCE<hw>]:BB:W3GPp:BSTation<st>:CHANnel<ch0>:HSDPa:CVPB.....	297
[.SOURCE<hw>]:BB:W3GPp:BSTation<st>:CHANnel<ch0>:HSDPa:HSET:ACLength.....	298
[.SOURCE<hw>]:BB:W3GPp:BSTation<st>:CHANnel<ch0>:HSDPa:HSET:ALTModulation.....	298
[.SOURCE<hw>]:BB:W3GPp:BSTation<st>:CHANnel<ch0>:HSDPa:HSET:AMODE.....	297
[.SOURCE<hw>]:BB:W3GPp:BSTation<st>:CHANnel<ch0>:HSDPa:HSET:BCBTi<di>?.....	298
[.SOURCE<hw>]:BB:W3GPp:BSTation<st>:CHANnel<ch0>:HSDPa:HSET:BPAYload<di>?.....	299
[.SOURCE<hw>]:BB:W3GPp:BSTation<st>:CHANnel<ch0>:HSDPa:HSET:CLENgtH.....	299
[.SOURCE<hw>]:BB:W3GPp:BSTation<st>:CHANnel<ch0>:HSDPa:HSET:CRATE<di>?.....	300
[.SOURCE<hw>]:BB:W3GPp:BSTation<st>:CHANnel<ch0>:HSDPa:HSET:DATA.....	300
[.SOURCE<hw>]:BB:W3GPp:BSTation<st>:CHANnel<ch0>:HSDPa:HSET:DATA:DSElect.....	300
[.SOURCE<hw>]:BB:W3GPp:BSTation<st>:CHANnel<ch0>:HSDPa:HSET:DATA:PATtern.....	301
[.SOURCE<hw>]:BB:W3GPp:BSTation<st>:CHANnel<ch0>:HSDPa:HSET:HARQ:LENGth.....	301
[.SOURCE<hw>]:BB:W3GPp:BSTation<st>:CHANnel<ch0>:HSDPa:HSET:HARQ:MODE.....	302
[.SOURCE<hw>]:BB:W3GPp:BSTation<st>:CHANnel<ch0>:HSDPa:HSET:HSCCode.....	302
[.SOURCE<hw>]:BB:W3GPp:BSTation<st>:CHANnel<ch0>:HSDPa:HSET:MODulation<di>.....	303
[.SOURCE<hw>]:BB:W3GPp:BSTation<st>:CHANnel<ch0>:HSDPa:HSET:NAIBitrate?.....	303
[.SOURCE<hw>]:BB:W3GPp:BSTation<st>:CHANnel<ch0>:HSDPa:HSET:PREDEfined.....	303

[SOURce<hw>]:BB:W3GPp:BSTation<st>:CHANnel<ch0>:HSDPa:HSET:PWPatter.....	304
[SOURce<hw>]:BB:W3GPp:BSTation<st>:CHANnel<ch0>:HSDPa:HSET:RVParameter<di>.....	304
[SOURce<hw>]:BB:W3GPp:BSTation<st>:CHANnel<ch0>:HSDPa:HSET:RVSequence<di>.....	305
[SOURce<hw>]:BB:W3GPp:BSTation<st>:CHANnel<ch0>:HSDPa:HSET:RVState.....	305
[SOURce<hw>]:BB:W3GPp:BSTation<st>:CHANnel<ch0>:HSDPa:HSET:S64Qam.....	306
[SOURce<hw>]:BB:W3GPp:BSTation<st>:CHANnel<ch0>:HSDPa:HSET:SCCode.....	307
[SOURce<hw>]:BB:W3GPp:BSTation<st>:CHANnel<ch0>:HSDPa:HSET:SEED.....	306
[SOURce<hw>]:BB:W3GPp:BSTation<st>:CHANnel<ch0>:HSDPa:HSET:SLENgth:ADJust.....	307
[SOURce<hw>]:BB:W3GPp:BSTation<st>:CHANnel<ch0>:HSDPa:HSET:SLENgth?.....	307
[SOURce<hw>]:BB:W3GPp:BSTation<st>:CHANnel<ch0>:HSDPa:HSET:SPATtern<di>?.....	308
[SOURce<hw>]:BB:W3GPp:BSTation<st>:CHANnel<ch0>:HSDPa:HSET:STAPattern.....	308
[SOURce<hw>]:BB:W3GPp:BSTation<st>:CHANnel<ch0>:HSDPa:HSET:TBS:INDEx<di>.....	309
[SOURce<hw>]:BB:W3GPp:BSTation<st>:CHANnel<ch0>:HSDPa:HSET:TBS:REFerence.....	310
[SOURce<hw>]:BB:W3GPp:BSTation<st>:CHANnel<ch0>:HSDPa:HSET:TBS:TABLE<di>.....	310
[SOURce<hw>]:BB:W3GPp:BSTation<st>:CHANnel<ch0>:HSDPa:HSET:TPOWer.....	309
[SOURce<hw>]:BB:W3GPp:BSTation<st>:CHANnel<ch0>:HSDPa:HSET:TYPE.....	311
[SOURce<hw>]:BB:W3GPp:BSTation<st>:CHANnel<ch0>:HSDPa:HSET:UECategory?.....	311
[SOURce<hw>]:BB:W3GPp:BSTation<st>:CHANnel<ch0>:HSDPa:HSET:UEID.....	312
[SOURce<hw>]:BB:W3GPp:BSTation<st>:CHANnel<ch0>:HSDPa:HSET:VIBSize<di>.....	312
[SOURce<hw>]:BB:W3GPp:BSTation<st>:CHANnel<ch0>:HSDPa:MIMO:CVPB<di>.....	312
[SOURce<hw>]:BB:W3GPp:BSTation<st>:CHANnel<ch0>:HSDPa:MIMO:MODulation<di>.....	313
[SOURce<hw>]:BB:W3GPp:BSTation<st>:CHANnel<ch0>:HSDPa:MIMO:PWPatter.....	313
[SOURce<hw>]:BB:W3GPp:BSTation<st>:CHANnel<ch0>:HSDPa:MIMO:STAPattern.....	313
[SOURce<hw>]:BB:W3GPp:BSTation<st>:CHANnel<ch0>:HSDPa:MODE.....	314
[SOURce<hw>]:BB:W3GPp:BSTation<st>:CHANnel<ch0>:HSDPa:TTIDistance.....	314
[SOURce<hw>]:BB:W3GPp:BSTation<st>:CHANnel<ch0>:POWer.....	315
[SOURce<hw>]:BB:W3GPp:BSTation<st>:CHANnel<ch0>:SFORmat.....	315
[SOURce<hw>]:BB:W3GPp:BSTation<st>:CHANnel<ch0>:SRATE.....	315
[SOURce<hw>]:BB:W3GPp:BSTation<st>:CHANnel<ch0>:STATE.....	316
[SOURce<hw>]:BB:W3GPp:BSTation<st>:CHANnel<ch0>:TOFFset.....	316
[SOURce<hw>]:BB:W3GPp:BSTation<st>:CHANnel<ch0>:TYPE.....	316
[SOURce<hw>]:BB:W3GPp:BSTation<st>:CHANnel<ch0>[:HSUPa]:EAGCh:IFCoding.....	317
[SOURce<hw>]:BB:W3GPp:BSTation<st>:CHANnel<ch0>[:HSUPa]:EAGCh:TTI<di>:AGSCope.....	318
[SOURce<hw>]:BB:W3GPp:BSTation<st>:CHANnel<ch0>[:HSUPa]:EAGCh:TTI<di>:AGVIndex.....	318
[SOURce<hw>]:BB:W3GPp:BSTation<st>:CHANnel<ch0>[:HSUPa]:EAGCh:TTI<di>:UEID.....	318
[SOURce<hw>]:BB:W3GPp:BSTation<st>:CHANnel<ch0>[:HSUPa]:EAGCh:TTICount.....	318
[SOURce<hw>]:BB:W3GPp:BSTation<st>:CHANnel<ch0>[:HSUPa]:EAGCh:TTIEdch.....	319
[SOURce<hw>]:BB:W3GPp:BSTation<st>:CHANnel<ch0>[:HSUPa]:EHICH:CTYPE.....	319
[SOURce<hw>]:BB:W3GPp:BSTation<st>:CHANnel<ch0>[:HSUPa]:EHICH:DTAU.....	320
[SOURce<hw>]:BB:W3GPp:BSTation<st>:CHANnel<ch0>[:HSUPa]:EHICH:ETAU?.....	320
[SOURce<hw>]:BB:W3GPp:BSTation<st>:CHANnel<ch0>[:HSUPa]:EHICH:RGPAtern.....	320
[SOURce<hw>]:BB:W3GPp:BSTation<st>:CHANnel<ch0>[:HSUPa]:EHICH:SSINdex.....	321
[SOURce<hw>]:BB:W3GPp:BSTation<st>:CHANnel<ch0>[:HSUPa]:EHICH:TTIEdch.....	321
[SOURce<hw>]:BB:W3GPp:BSTation<st>:CHANnel<ch0>[:HSUPa]:ERGCh:CTYPE.....	321
[SOURce<hw>]:BB:W3GPp:BSTation<st>:CHANnel<ch0>[:HSUPa]:ERGCh:DTAU.....	321
[SOURce<hw>]:BB:W3GPp:BSTation<st>:CHANnel<ch0>[:HSUPa]:ERGCh:ETAU?.....	322
[SOURce<hw>]:BB:W3GPp:BSTation<st>:CHANnel<ch0>[:HSUPa]:ERGCh:RGPAtern.....	322
[SOURce<hw>]:BB:W3GPp:BSTation<st>:CHANnel<ch0>[:HSUPa]:ERGCh:SSINdex.....	322
[SOURce<hw>]:BB:W3GPp:BSTation<st>:CHANnel<ch0>[:HSUPa]:ERGCh:TTIEdch.....	323
[SOURce<hw>]:BB:W3GPp:BSTation<st>:CMODE:DLFStructure.....	323

[.SOURce<hw>]:BB:W3GPp:BSTation<st>:CMODE:METhod.....	323
[.SOURce<hw>]:BB:W3GPp:BSTation<st>:CMODE:PATtern<ch>:TGD.....	324
[.SOURce<hw>]:BB:W3GPp:BSTation<st>:CMODE:PATtern<ch>:TGL<di>.....	324
[.SOURce<hw>]:BB:W3GPp:BSTation<st>:CMODE:PATtern<ch>:TGPL.....	324
[.SOURce<hw>]:BB:W3GPp:BSTation<st>:CMODE:PATtern<ch>:TGSN.....	324
[.SOURce<hw>]:BB:W3GPp:BSTation<st>:CMODE:STATe.....	326
[.SOURce<hw>]:BB:W3GPp:BSTation<st>:DCONflict:RESolve.....	326
[.SOURce<hw>]:BB:W3GPp:BSTation<st>:DCONflict[:STATe]?.....	326
[.SOURce<hw>]:BB:W3GPp:BSTation<st>:ENHanced:CHANnel<ch0>:DPCH:DPControl:RANGe:UP.....	344
[.SOURce<hw>]:BB:W3GPp:BSTation<st>:ENHanced:PCPich:PATtern.....	330
[.SOURce<hw>]:BB:W3GPp:BSTation<st>:OLTDiversity.....	326
[.SOURce<hw>]:BB:W3GPp:BSTation<st>:PINDicator:COUNT.....	327
[.SOURce<hw>]:BB:W3GPp:BSTation<st>:SCODE.....	327
[.SOURce<hw>]:BB:W3GPp:BSTation<st>:SCODE:STATe.....	327
[.SOURce<hw>]:BB:W3GPp:BSTation<st>:SCPich:PREference[:STATe].....	328
[.SOURce<hw>]:BB:W3GPp:BSTation<st>:SSCG?.....	328
[.SOURce<hw>]:BB:W3GPp:BSTation<st>:STATe.....	328
[.SOURce<hw>]:BB:W3GPp:BSTation<st>:TDElay.....	329
[.SOURce<hw>]:BB:W3GPp:BSTation<st>:TDIVersity.....	329
[.SOURce<hw>]:BB:W3GPp:BSTation<st> MSTation<st>:CMODE:POFFset.....	325
[.SOURce<hw>]:BB:W3GPp:BSTation<st> MSTation<st>:CMODE:POMode.....	325
[.SOURce<hw>]:BB:W3GPp:CLIPping:LEVel.....	266
[.SOURce<hw>]:BB:W3GPp:CLIPping:MODE.....	267
[.SOURce<hw>]:BB:W3GPp:CLIPping:STATe.....	267
[.SOURce<hw>]:BB:W3GPp:CLOCK:SOURce.....	277
[.SOURce<hw>]:BB:W3GPp:COPIY:COFFset.....	263
[.SOURce<hw>]:BB:W3GPp:COPIY:DESTination.....	264
[.SOURce<hw>]:BB:W3GPp:COPIY:EXECute.....	264
[.SOURce<hw>]:BB:W3GPp:COPIY:SOURce.....	264
[.SOURce<hw>]:BB:W3GPp:CRATe:VARiation.....	268
[.SOURce<hw>]:BB:W3GPp:CRATe?.....	267
[.SOURce<hw>]:BB:W3GPp:FILTer:PARAmeter:APCO25.....	268
[.SOURce<hw>]:BB:W3GPp:FILTer:PARAmeter:COSSine.....	268
[.SOURce<hw>]:BB:W3GPp:FILTer:PARAmeter:GAUSSs.....	268
[.SOURce<hw>]:BB:W3GPp:FILTer:PARAmeter:LPASSs.....	269
[.SOURce<hw>]:BB:W3GPp:FILTer:PARAmeter:LPASSEVM.....	269
[.SOURce<hw>]:BB:W3GPp:FILTer:PARAmeter:RCOSSine.....	269
[.SOURce<hw>]:BB:W3GPp:FILTer:PARAmeter:SPHase.....	270
[.SOURce<hw>]:BB:W3GPp:FILTer:TYPE.....	270
[.SOURce<hw>]:BB:W3GPp:LINK.....	265
[.SOURce<hw>]:BB:W3GPp:LREFerence.....	355
[.SOURce<hw>]:BB:W3GPp:MSTation:ADDitional:COUNT.....	351
[.SOURce<hw>]:BB:W3GPp:MSTation:ADDitional:POWER:OFFSet.....	351
[.SOURce<hw>]:BB:W3GPp:MSTation:ADDitional:SCODE:STEP.....	352
[.SOURce<hw>]:BB:W3GPp:MSTation:ADDitional:STATe.....	352
[.SOURce<hw>]:BB:W3GPp:MSTation:ADDitional:TDElay:STEP.....	352
[.SOURce<hw>]:BB:W3GPp:MSTation:ENHanced:DPDCh:BPFRame?.....	431
[.SOURce<hw>]:BB:W3GPp:MSTation:ENHanced:DPDCh:CCODing:STATe.....	432
[.SOURce<hw>]:BB:W3GPp:MSTation:ENHanced:DPDCh:CCODing:TYPE.....	432
[.SOURce<hw>]:BB:W3GPp:MSTation:ENHanced:DPDCh:CCODing:USER:CATalog?.....	433

[:SOURce<hw>]:BB:W3GPp:MSTation:ENHanced:DPDCh:CCODing:USER:DELeTe.....	433
[:SOURce<hw>]:BB:W3GPp:MSTation:ENHanced:DPDCh:CCODing:USER:LOAD.....	434
[:SOURce<hw>]:BB:W3GPp:MSTation:ENHanced:DPDCh:CCODing:USER:STORe.....	434
[:SOURce<hw>]:BB:W3GPp:MSTation:ENHanced:DPDCh:DERRor:BIT:LAYer.....	435
[:SOURce<hw>]:BB:W3GPp:MSTation:ENHanced:DPDCh:DERRor:BIT:RATE.....	435
[:SOURce<hw>]:BB:W3GPp:MSTation:ENHanced:DPDCh:DERRor:BIT:STATe.....	435
[:SOURce<hw>]:BB:W3GPp:MSTation:ENHanced:DPDCh:DERRor:BLOCK:RATE.....	436
[:SOURce<hw>]:BB:W3GPp:MSTation:ENHanced:DPDCh:DERRor[BLOCK]:STATe.....	436
[:SOURce<hw>]:BB:W3GPp:MSTation:ENHanced:DPDCh:INTerleaver2.....	436
[:SOURce<hw>]:BB:W3GPp:MSTation:ENHanced:DPDCh:ORATe.....	437
[:SOURce<hw>]:BB:W3GPp:MSTation:ENHanced:DPDCh:STATe.....	437
[:SOURce<hw>]:BB:W3GPp:MSTation:ENHanced:DPDCh:TCHannel<di0>:CRCSiZe.....	439
[:SOURce<hw>]:BB:W3GPp:MSTation:ENHanced:DPDCh:TCHannel<di0>:DATA.....	439
[:SOURce<hw>]:BB:W3GPp:MSTation:ENHanced:DPDCh:TCHannel<di0>:DATA:DSELeCt.....	440
[:SOURce<hw>]:BB:W3GPp:MSTation:ENHanced:DPDCh:TCHannel<di0>:DATA:PATTern.....	440
[:SOURce<hw>]:BB:W3GPp:MSTation:ENHanced:DPDCh:TCHannel<di0>:EPRotectiOn.....	441
[:SOURce<hw>]:BB:W3GPp:MSTation:ENHanced:DPDCh:TCHannel<di0>:INTerleaver.....	441
[:SOURce<hw>]:BB:W3GPp:MSTation:ENHanced:DPDCh:TCHannel<di0>:RMAtributE.....	437
[:SOURce<hw>]:BB:W3GPp:MSTation:ENHanced:DPDCh:TCHannel<di0>:STATe.....	438
[:SOURce<hw>]:BB:W3GPp:MSTation:ENHanced:DPDCh:TCHannel<di0>:TBCount.....	438
[:SOURce<hw>]:BB:W3GPp:MSTation:ENHanced:DPDCh:TCHannel<di0>:TBSiZe.....	438
[:SOURce<hw>]:BB:W3GPp:MSTation:ENHanced:DPDCh:TCHannel<di0>:TTINterval.....	439
[:SOURce<hw>]:BB:W3GPp:MSTation:ENHanced:PCPCh:CCODing:STATe.....	441
[:SOURce<hw>]:BB:W3GPp:MSTation:ENHanced:PCPCh:CCODing:TYPE.....	442
[:SOURce<hw>]:BB:W3GPp:MSTation:PRESet.....	353
[:SOURce<hw>]:BB:W3GPp:MSTation:UDTX:BURSt<ch>.....	426
[:SOURce<hw>]:BB:W3GPp:MSTation:UDTX:CYCLe<ch>.....	426
[:SOURce<hw>]:BB:W3GPp:MSTation:UDTX:ITHReshold.....	425
[:SOURce<hw>]:BB:W3GPp:MSTation:UDTX:LPLength.....	425
[:SOURce<hw>]:BB:W3GPp:MSTation:UDTX:MODE.....	424
[:SOURce<hw>]:BB:W3GPp:MSTation:UDTX:OFFSet.....	425
[:SOURce<hw>]:BB:W3GPp:MSTation:UDTX:POSTamble<ch>?.....	427
[:SOURce<hw>]:BB:W3GPp:MSTation:UDTX:PREamble<ch>?.....	426
[:SOURce<hw>]:BB:W3GPp:MSTation:UDTX:STATe.....	424
[:SOURce<hw>]:BB:W3GPp:MSTation:UDTX:TTIEdch.....	425
[:SOURce<hw>]:BB:W3GPp:MSTation[ENHanced:DPDCh]:DPControl:ASSignment.....	428
[:SOURce<hw>]:BB:W3GPp:MSTation[ENHanced:DPDCh]:DPControl:DIRectiOn.....	428
[:SOURce<hw>]:BB:W3GPp:MSTation[ENHanced:DPDCh]:DPControl:MODE.....	429
[:SOURce<hw>]:BB:W3GPp:MSTation[ENHanced:DPDCh]:DPControl:RANGe:DOWN.....	429
[:SOURce<hw>]:BB:W3GPp:MSTation[ENHanced:DPDCh]:DPControl:RANGe:UP.....	429
[:SOURce<hw>]:BB:W3GPp:MSTation[ENHanced:DPDCh]:DPControl:STATe.....	430
[:SOURce<hw>]:BB:W3GPp:MSTation[ENHanced:DPDCh]:DPControl:STEP:MANual.....	430
[:SOURce<hw>]:BB:W3GPp:MSTation[ENHanced:DPDCh]:DPControl:STEP[EXTerNal].....	430
[:SOURce<hw>]:BB:W3GPp:MSTation[ENHanced:DPDCh]:DPControl[POWER]?.....	429
[:SOURce<hw>]:BB:W3GPp:MSTation<st>:CHANnel<ch>:DPDCh:CCODE?.....	382
[:SOURce<hw>]:BB:W3GPp:MSTation<st>:CHANnel<ch>:DPDCh:DATA.....	382
[:SOURce<hw>]:BB:W3GPp:MSTation<st>:CHANnel<ch>:DPDCh:DATA:DSELeCt.....	383
[:SOURce<hw>]:BB:W3GPp:MSTation<st>:CHANnel<ch>:DPDCh:DATA:PATTern.....	384
[:SOURce<hw>]:BB:W3GPp:MSTation<st>:CHANnel<ch>:DPDCh:SRATE?.....	384
[:SOURce<hw>]:BB:W3GPp:MSTation<st>:CMODE:METhod.....	356

[:SOURce<hw>]:BB:W3GPp:MSTation<st>:CMODE:PATtern<ch>:TGD.....	356
[:SOURce<hw>]:BB:W3GPp:MSTation<st>:CMODE:PATtern<ch>:TGL<di>.....	356
[:SOURce<hw>]:BB:W3GPp:MSTation<st>:CMODE:PATtern<ch>:TGPL.....	357
[:SOURce<hw>]:BB:W3GPp:MSTation<st>:CMODE:PATtern<ch>:TGSN.....	357
[:SOURce<hw>]:BB:W3GPp:MSTation<st>:CMODE:STATE.....	357
[:SOURce<hw>]:BB:W3GPp:MSTation<st>:DPCCh:CCODE?.....	358
[:SOURce<hw>]:BB:W3GPp:MSTation<st>:DPCCh:FBI:MODE.....	358
[:SOURce<hw>]:BB:W3GPp:MSTation<st>:DPCCh:FBI:PATtern.....	359
[:SOURce<hw>]:BB:W3GPp:MSTation<st>:DPCCh:HS:CCODE?.....	365
[:SOURce<hw>]:BB:W3GPp:MSTation<st>:DPCCh:HS:COMPAtibility.....	365
[:SOURce<hw>]:BB:W3GPp:MSTation<st>:DPCCh:HS:CQI:PLENgtH.....	368
[:SOURce<hw>]:BB:W3GPp:MSTation<st>:DPCCh:HS:CQI<ch>[:VALues].....	368
[:SOURce<hw>]:BB:W3GPp:MSTation<st>:DPCCh:HS:HACK:REPeat.....	381
[:SOURce<hw>]:BB:W3GPp:MSTation<st>:DPCCh:HS:HACK:ROWS.....	377
[:SOURce<hw>]:BB:W3GPp:MSTation<st>:DPCCh:HS:HAPattern.....	367
[:SOURce<hw>]:BB:W3GPp:MSTation<st>:DPCCh:HS:MIMO:POAAck.....	369
[:SOURce<hw>]:BB:W3GPp:MSTation<st>:DPCCh:HS:MIMO:POANack.....	370
[:SOURce<hw>]:BB:W3GPp:MSTation<st>:DPCCh:HS:MIMO:POCA.....	371
[:SOURce<hw>]:BB:W3GPp:MSTation<st>:DPCCh:HS:MIMO:PONAck.....	370
[:SOURce<hw>]:BB:W3GPp:MSTation<st>:DPCCh:HS:MIMO:PONNack.....	371
[:SOURce<hw>]:BB:W3GPp:MSTation<st>:DPCCh:HS:MIMO:TTI<ch0>:CQI<di>.....	373
[:SOURce<hw>]:BB:W3GPp:MSTation<st>:DPCCh:HS:MIMO:TTI<ch0>:CQIType.....	373
[:SOURce<hw>]:BB:W3GPp:MSTation<st>:DPCCh:HS:MIMO:TTI<ch0>:HACK.....	372
[:SOURce<hw>]:BB:W3GPp:MSTation<st>:DPCCh:HS:MIMO:TTI<ch0>:PCI.....	373
[:SOURce<hw>]:BB:W3GPp:MSTation<st>:DPCCh:HS:MIMO:TTICount.....	372
[:SOURce<hw>]:BB:W3GPp:MSTation<st>:DPCCh:HS:MIMO[:MODE].....	369
[:SOURce<hw>]:BB:W3GPp:MSTation<st>:DPCCh:HS:MMODE.....	376
[:SOURce<hw>]:BB:W3GPp:MSTation<st>:DPCCh:HS:PCQI:REPeat.....	381
[:SOURce<hw>]:BB:W3GPp:MSTation<st>:DPCCh:HS:PCQI:ROWS.....	377
[:SOURce<hw>]:BB:W3GPp:MSTation<st>:DPCCh:HS:POACK.....	367
[:SOURce<hw>]:BB:W3GPp:MSTation<st>:DPCCh:HS:PONAck.....	367
[:SOURce<hw>]:BB:W3GPp:MSTation<st>:DPCCh:HS:POWer.....	365
[:SOURce<hw>]:BB:W3GPp:MSTation<st>:DPCCh:HS:ROW<ch0>:HACK:FROM.....	377
[:SOURce<hw>]:BB:W3GPp:MSTation<st>:DPCCh:HS:ROW<ch0>:HACK:TO.....	377
[:SOURce<hw>]:BB:W3GPp:MSTation<st>:DPCCh:HS:ROW<ch0>:HACK<di>.....	377
[:SOURce<hw>]:BB:W3GPp:MSTation<st>:DPCCh:HS:ROW<ch0>:PCQI:FROM.....	379
[:SOURce<hw>]:BB:W3GPp:MSTation<st>:DPCCh:HS:ROW<ch0>:PCQI:TO.....	379
[:SOURce<hw>]:BB:W3GPp:MSTation<st>:DPCCh:HS:ROW<ch0>:PCQI<di>:CQI<us>.....	380
[:SOURce<hw>]:BB:W3GPp:MSTation<st>:DPCCh:HS:ROW<ch0>:PCQI<di>:PCI.....	380
[:SOURce<hw>]:BB:W3GPp:MSTation<st>:DPCCh:HS:ROW<ch0>:PCQI<di>:TYPE.....	379
[:SOURce<hw>]:BB:W3GPp:MSTation<st>:DPCCh:HS:ROW<ch0>:POHAck.....	379
[:SOURce<hw>]:BB:W3GPp:MSTation<st>:DPCCh:HS:ROW<ch0>:POPCqI.....	380
[:SOURce<hw>]:BB:W3GPp:MSTation<st>:DPCCh:HS:SC:ACTive.....	376
[:SOURce<hw>]:BB:W3GPp:MSTation<st>:DPCCh:HS:SC:ENABled.....	376
[:SOURce<hw>]:BB:W3GPp:MSTation<st>:DPCCh:HS:SDElay.....	366
[:SOURce<hw>]:BB:W3GPp:MSTation<st>:DPCCh:HS:SFOrmat?.....	376
[:SOURce<hw>]:BB:W3GPp:MSTation<st>:DPCCh:HS:SLENgtH:ADJust.....	382
[:SOURce<hw>]:BB:W3GPp:MSTation<st>:DPCCh:HS:SLENgtH?.....	381
[:SOURce<hw>]:BB:W3GPp:MSTation<st>:DPCCh:HS:STATE.....	364
[:SOURce<hw>]:BB:W3GPp:MSTation<st>:DPCCh:HS:TTIDistance.....	366



[:SOURce<hw>]:BB:W3GPp:MSTation<st>:DPCCh:POWer.....	359
[:SOURce<hw>]:BB:W3GPp:MSTation<st>:DPCCh:SFOrmat.....	359
[:SOURce<hw>]:BB:W3GPp:MSTation<st>:DPCCh:TFCI.....	360
[:SOURce<hw>]:BB:W3GPp:MSTation<st>:DPCCh:TFCI:STATe.....	360
[:SOURce<hw>]:BB:W3GPp:MSTation<st>:DPCCh:TOFFset.....	361
[:SOURce<hw>]:BB:W3GPp:MSTation<st>:DPCCh:TPC:DATA.....	361
[:SOURce<hw>]:BB:W3GPp:MSTation<st>:DPCCh:TPC:DATA:DSElect.....	361
[:SOURce<hw>]:BB:W3GPp:MSTation<st>:DPCCh:TPC:DATA:PATtern.....	362
[:SOURce<hw>]:BB:W3GPp:MSTation<st>:DPCCh:TPC:MISuse.....	362
[:SOURce<hw>]:BB:W3GPp:MSTation<st>:DPCCh:TPC:MODE.....	363
[:SOURce<hw>]:BB:W3GPp:MSTation<st>:DPCCh:TPC:PSTEp.....	363
[:SOURce<hw>]:BB:W3GPp:MSTation<st>:DPCCh:TPC:READ.....	364
[:SOURce<hw>]:BB:W3GPp:MSTation<st>:DPDCh:FCIO.....	384
[:SOURce<hw>]:BB:W3GPp:MSTation<st>:DPDCh:ORATe.....	385
[:SOURce<hw>]:BB:W3GPp:MSTation<st>:DPDCh:POWer.....	385
[:SOURce<hw>]:BB:W3GPp:MSTation<st>:DPDCh:STATe.....	385
[:SOURce<hw>]:BB:W3GPp:MSTation<st>:ENHanced:PRACH:CCODing:STATe.....	442
[:SOURce<hw>]:BB:W3GPp:MSTation<st>:ENHanced:PRACH:CCODing:TYPE.....	442
[:SOURce<hw>]:BB:W3GPp:MSTation<st>:MODE.....	353
[:SOURce<hw>]:BB:W3GPp:MSTation<st>:PCPCh:CPOWer.....	386
[:SOURce<hw>]:BB:W3GPp:MSTation<st>:PCPCh:CPSFormat.....	387
[:SOURce<hw>]:BB:W3GPp:MSTation<st>:PCPCh:DATA.....	387
[:SOURce<hw>]:BB:W3GPp:MSTation<st>:PCPCh:DATA:DSElect.....	388
[:SOURce<hw>]:BB:W3GPp:MSTation<st>:PCPCh:DATA:PATtern.....	388
[:SOURce<hw>]:BB:W3GPp:MSTation<st>:PCPCh:DPOWer.....	388
[:SOURce<hw>]:BB:W3GPp:MSTation<st>:PCPCh:FBI:MODE.....	389
[:SOURce<hw>]:BB:W3GPp:MSTation<st>:PCPCh:FBI:PATtern.....	389
[:SOURce<hw>]:BB:W3GPp:MSTation<st>:PCPCh:MLEngth.....	389
[:SOURce<hw>]:BB:W3GPp:MSTation<st>:PCPCh:PLEngth.....	390
[:SOURce<hw>]:BB:W3GPp:MSTation<st>:PCPCh:PPOWer.....	390
[:SOURce<hw>]:BB:W3GPp:MSTation<st>:PCPCh:PPOWer:STEP.....	390
[:SOURce<hw>]:BB:W3GPp:MSTation<st>:PCPCh:PREPetition.....	391
[:SOURce<hw>]:BB:W3GPp:MSTation<st>:PCPCh:RAFTer.....	391
[:SOURce<hw>]:BB:W3GPp:MSTation<st>:PCPCh:RARB.....	391
[:SOURce<hw>]:BB:W3GPp:MSTation<st>:PCPCh:SIGNature.....	392
[:SOURce<hw>]:BB:W3GPp:MSTation<st>:PCPCh:SRATe.....	392
[:SOURce<hw>]:BB:W3GPp:MSTation<st>:PCPCh:TFCI.....	393
[:SOURce<hw>]:BB:W3GPp:MSTation<st>:PCPCh:TIMing:DPOWer:MPART?.....	393
[:SOURce<hw>]:BB:W3GPp:MSTation<st>:PCPCh:TIMing:DPOWer:PREamble?.....	393
[:SOURce<hw>]:BB:W3GPp:MSTation<st>:PCPCh:TIMing:SOFFset.....	394
[:SOURce<hw>]:BB:W3GPp:MSTation<st>:PCPCh:TIMing:SPERiod?.....	394
[:SOURce<hw>]:BB:W3GPp:MSTation<st>:PCPCh:TIMing:TIME:PREMp.....	394
[:SOURce<hw>]:BB:W3GPp:MSTation<st>:PCPCh:TIMing:TIME:PREPre.....	395
[:SOURce<hw>]:BB:W3GPp:MSTation<st>:PCPCh:TPC:DATA.....	395
[:SOURce<hw>]:BB:W3GPp:MSTation<st>:PCPCh:TPC:DATA:DSElect.....	395
[:SOURce<hw>]:BB:W3GPp:MSTation<st>:PCPCh:TPC:DATA:PATtern.....	396
[:SOURce<hw>]:BB:W3GPp:MSTation<st>:PCPCh:TPC:READ.....	396
[:SOURce<hw>]:BB:W3GPp:MSTation<st>:PRACH:ATTiming.....	397
[:SOURce<hw>]:BB:W3GPp:MSTation<st>:PRACH:CPOWer.....	398
[:SOURce<hw>]:BB:W3GPp:MSTation<st>:PRACH:DATA.....	398

[ :SOURce<hw>]:BB:W3GPp:MSStation<st>:PRACH:DATA:DSElect.....	399
[ :SOURce<hw>]:BB:W3GPp:MSStation<st>:PRACH:DATA:PATtern.....	399
[ :SOURce<hw>]:BB:W3GPp:MSStation<st>:PRACH:DPOWer.....	399
[ :SOURce<hw>]:BB:W3GPp:MSStation<st>:PRACH:MLENght.....	400
[ :SOURce<hw>]:BB:W3GPp:MSStation<st>:PRACH:PPOWer.....	400
[ :SOURce<hw>]:BB:W3GPp:MSStation<st>:PRACH:PPOWer:STEP.....	400
[ :SOURce<hw>]:BB:W3GPp:MSStation<st>:PRACH:PREPetition.....	401
[ :SOURce<hw>]:BB:W3GPp:MSStation<st>:PRACH:RAFTer.....	401
[ :SOURce<hw>]:BB:W3GPp:MSStation<st>:PRACH:RARB.....	401
[ :SOURce<hw>]:BB:W3GPp:MSStation<st>:PRACH:SFOrmat.....	402
[ :SOURce<hw>]:BB:W3GPp:MSStation<st>:PRACH:SIGNature.....	402
[ :SOURce<hw>]:BB:W3GPp:MSStation<st>:PRACH:SRATe.....	402
[ :SOURce<hw>]:BB:W3GPp:MSStation<st>:PRACH:TFCI.....	403
[ :SOURce<hw>]:BB:W3GPp:MSStation<st>:PRACH:TIMing:DPOWer:MPARt:CONTRol?.....	404
[ :SOURce<hw>]:BB:W3GPp:MSStation<st>:PRACH:TIMing:DPOWer:MPARt:DATA?.....	404
[ :SOURce<hw>]:BB:W3GPp:MSStation<st>:PRACH:TIMing:DPOWer:MPARt?.....	403
[ :SOURce<hw>]:BB:W3GPp:MSStation<st>:PRACH:TIMing:DPOWer:PREamble?.....	404
[ :SOURce<hw>]:BB:W3GPp:MSStation<st>:PRACH:TIMing:SOFFset.....	405
[ :SOURce<hw>]:BB:W3GPp:MSStation<st>:PRACH:TIMing:SPERiod?.....	405
[ :SOURce<hw>]:BB:W3GPp:MSStation<st>:PRACH:TIMing:TIME:PREMp.....	405
[ :SOURce<hw>]:BB:W3GPp:MSStation<st>:PRACH:TIMing:TIME:PREPre.....	406
[ :SOURce<hw>]:BB:W3GPp:MSStation<st>:SCODE.....	354
[ :SOURce<hw>]:BB:W3GPp:MSStation<st>:SCODE:MODE.....	354
[ :SOURce<hw>]:BB:W3GPp:MSStation<st>:STATE.....	354
[ :SOURce<hw>]:BB:W3GPp:MSStation<st>:TDElay.....	355
[ :SOURce<hw>]:BB:W3GPp:MSStation<st>[:HSUPa]:CHANnel<ch>:DPDCh:E:CCODE?.....	407
[ :SOURce<hw>]:BB:W3GPp:MSStation<st>[:HSUPa]:CHANnel<ch>:DPDCh:E:DATA.....	408
[ :SOURce<hw>]:BB:W3GPp:MSStation<st>[:HSUPa]:CHANnel<ch>:DPDCh:E:DATA:DSElect.....	408
[ :SOURce<hw>]:BB:W3GPp:MSStation<st>[:HSUPa]:CHANnel<ch>:DPDCh:E:DATA:PATtern.....	409
[ :SOURce<hw>]:BB:W3GPp:MSStation<st>[:HSUPa]:CHANnel<ch>:DPDCh:E:POWer.....	409
[ :SOURce<hw>]:BB:W3GPp:MSStation<st>[:HSUPa]:CHANnel<ch>:DPDCh:E:SRATe?.....	409
[ :SOURce<hw>]:BB:W3GPp:MSStation<st>[:HSUPa]:DPCCh:E:CCODE?.....	419
[ :SOURce<hw>]:BB:W3GPp:MSStation<st>[:HSUPa]:DPCCh:E:FRC:CHANnel.....	410
[ :SOURce<hw>]:BB:W3GPp:MSStation<st>[:HSUPa]:DPCCh:E:FRC:CRATe?.....	410
[ :SOURce<hw>]:BB:W3GPp:MSStation<st>[:HSUPa]:DPCCh:E:FRC:DATA.....	410
[ :SOURce<hw>]:BB:W3GPp:MSStation<st>[:HSUPa]:DPCCh:E:FRC:DATA:DSElect.....	411
[ :SOURce<hw>]:BB:W3GPp:MSStation<st>[:HSUPa]:DPCCh:E:FRC:DATA:PATtern.....	411
[ :SOURce<hw>]:BB:W3GPp:MSStation<st>[:HSUPa]:DPCCh:E:FRC:DERRor:BIT:LAYer.....	412
[ :SOURce<hw>]:BB:W3GPp:MSStation<st>[:HSUPa]:DPCCh:E:FRC:DERRor:BIT:RATE.....	412
[ :SOURce<hw>]:BB:W3GPp:MSStation<st>[:HSUPa]:DPCCh:E:FRC:DERRor:BIT:STATe.....	412
[ :SOURce<hw>]:BB:W3GPp:MSStation<st>[:HSUPa]:DPCCh:E:FRC:DERRor:BLOCK:RATE.....	413
[ :SOURce<hw>]:BB:W3GPp:MSStation<st>[:HSUPa]:DPCCh:E:FRC:DERRor:BLOCK:STATe.....	413
[ :SOURce<hw>]:BB:W3GPp:MSStation<st>[:HSUPa]:DPCCh:E:FRC:DTX:PATtern.....	413
[ :SOURce<hw>]:BB:W3GPp:MSStation<st>[:HSUPa]:DPCCh:E:FRC:DTX:STATe.....	413
[ :SOURce<hw>]:BB:W3GPp:MSStation<st>[:HSUPa]:DPCCh:E:FRC:HARQ:SIMulation:MODE.....	414
[ :SOURce<hw>]:BB:W3GPp:MSStation<st>[:HSUPa]:DPCCh:E:FRC:HARQ:SIMulation:RVZero.....	414
[ :SOURce<hw>]:BB:W3GPp:MSStation<st>[:HSUPa]:DPCCh:E:FRC:HARQ:SIMulation[:STATe].....	414
[ :SOURce<hw>]:BB:W3GPp:MSStation<st>[:HSUPa]:DPCCh:E:FRC:HARQ[:SIMulation]:PATtern<ch>.....	415
[ :SOURce<hw>]:BB:W3GPp:MSStation<st>[:HSUPa]:DPCCh:E:FRC:HPRocesses?.....	415
[ :SOURce<hw>]:BB:W3GPp:MSStation<st>[:HSUPa]:DPCCh:E:FRC:MIBRate?.....	415

[ :SOURce<hw>]:BB:W3GPp:MSTation<st>[:HSUPa]:DPCCh:E:FRC:MODulation.....	416
[ :SOURce<hw>]:BB:W3GPp:MSTation<st>[:HSUPa]:DPCCh:E:FRC:ORATe.....	416
[ :SOURce<hw>]:BB:W3GPp:MSTation<st>[:HSUPa]:DPCCh:E:FRC:PAYBits?.....	416
[ :SOURce<hw>]:BB:W3GPp:MSTation<st>[:HSUPa]:DPCCh:E:FRC:STATe.....	417
[ :SOURce<hw>]:BB:W3GPp:MSTation<st>[:HSUPa]:DPCCh:E:FRC:TBS:INDeX.....	417
[ :SOURce<hw>]:BB:W3GPp:MSTation<st>[:HSUPa]:DPCCh:E:FRC:TBS:TABLE.....	417
[ :SOURce<hw>]:BB:W3GPp:MSTation<st>[:HSUPa]:DPCCh:E:FRC:TTIBits?.....	418
[ :SOURce<hw>]:BB:W3GPp:MSTation<st>[:HSUPa]:DPCCh:E:FRC:TTIEdch.....	418
[ :SOURce<hw>]:BB:W3GPp:MSTation<st>[:HSUPa]:DPCCh:E:FRC:UECategory?.....	419
[ :SOURce<hw>]:BB:W3GPp:MSTation<st>[:HSUPa]:DPCCh:E:HBIT.....	419
[ :SOURce<hw>]:BB:W3GPp:MSTation<st>[:HSUPa]:DPCCh:E:POWeR.....	419
[ :SOURce<hw>]:BB:W3GPp:MSTation<st>[:HSUPa]:DPCCh:E:RSNumber.....	420
[ :SOURce<hw>]:BB:W3GPp:MSTation<st>[:HSUPa]:DPCCh:E:STATe.....	420
[ :SOURce<hw>]:BB:W3GPp:MSTation<st>[:HSUPa]:DPCCh:E:TFCI.....	420
[ :SOURce<hw>]:BB:W3GPp:MSTation<st>[:HSUPa]:DPDCh:E:FCIO.....	421
[ :SOURce<hw>]:BB:W3GPp:MSTation<st>[:HSUPa]:DPDCh:E:MODulation.....	421
[ :SOURce<hw>]:BB:W3GPp:MSTation<st>[:HSUPa]:DPDCh:E:ORATe.....	421
[ :SOURce<hw>]:BB:W3GPp:MSTation<st>[:HSUPa]:DPDCh:E:STATe.....	422
[ :SOURce<hw>]:BB:W3GPp:MSTation<st>[:HSUPa]:DPDCh:E:TTIEdch.....	422
[ :SOURce<hw>]:BB:W3GPp:MSTation<st>[:HSUPa]:EDCH:REPeat.....	422
[ :SOURce<hw>]:BB:W3GPp:MSTation<st>[:HSUPa]:EDCH:ROW<ch0>:FROM.....	423
[ :SOURce<hw>]:BB:W3GPp:MSTation<st>[:HSUPa]:EDCH:ROW<ch0>:TO.....	423
[ :SOURce<hw>]:BB:W3GPp:MSTation<st>[:HSUPa]:EDCH:ROWCount.....	423
[ :SOURce<hw>]:BB:W3GPp:MSTation<st>[:HSUPa]:EDCH:TTIEdch.....	422
[ :SOURce<hw>]:BB:W3GPp:POWeR:ADJust.....	265
[ :SOURce<hw>]:BB:W3GPp:POWeR[:TOTal]?.....	265
[ :SOURce<hw>]:BB:W3GPp:PPARameter:CRESt.....	278
[ :SOURce<hw>]:BB:W3GPp:PPARameter:DPCH:COUNT.....	279
[ :SOURce<hw>]:BB:W3GPp:PPARameter:DPCH:SRATe.....	279
[ :SOURce<hw>]:BB:W3GPp:PPARameter:EXECute.....	279
[ :SOURce<hw>]:BB:W3GPp:PPARameter:SCCPch:SRATe.....	280
[ :SOURce<hw>]:BB:W3GPp:PPARameter:SCCPch:STATe.....	280
[ :SOURce<hw>]:BB:W3GPp:PPARameter:SCHannels.....	280
[ :SOURce<hw>]:BB:W3GPp:PRESet.....	260
[ :SOURce<hw>]:BB:W3GPp:SETTing:CATalog?.....	260
[ :SOURce<hw>]:BB:W3GPp:SETTing:DELeTe.....	261
[ :SOURce<hw>]:BB:W3GPp:SETTing:LOAD.....	261
[ :SOURce<hw>]:BB:W3GPp:SETTing:STORe.....	262
[ :SOURce<hw>]:BB:W3GPp:SETTing:TMODeL:BSTation.....	281
[ :SOURce<hw>]:BB:W3GPp:SETTing:TMODeL:BSTation:CATalog?.....	281
[ :SOURce<hw>]:BB:W3GPp:SETTing:TMODeL:MSTation.....	281
[ :SOURce<hw>]:BB:W3GPp:SETTing:TMODeL:MSTation:CATalog?.....	282
[ :SOURce<hw>]:BB:W3GPp:SLENgth.....	262
[ :SOURce<hw>]:BB:W3GPp:STATe.....	262
[ :SOURce<hw>]:BB:W3GPp:TRIGger:ARM:EXECute.....	272
[ :SOURce<hw>]:BB:W3GPp:TRIGger:EXECute.....	272
[ :SOURce<hw>]:BB:W3GPp:TRIGger:EXTeRnal:SYNChronize:OUTPut.....	273
[ :SOURce<hw>]:BB:W3GPp:TRIGger:OUTPut<ch>:DELay.....	277
[ :SOURce<hw>]:BB:W3GPp:TRIGger:OUTPut<ch>:MODE.....	276
[ :SOURce<hw>]:BB:W3GPp:TRIGger:OUTPut<ch>:OFFTime.....	276

[:SOURce<hw>]:BB:W3GPP:TRIGger:OUTPut<ch>:ONTime.....	276
[:SOURce<hw>]:BB:W3GPP:TRIGger:OUTPut<ch>:PERiod.....	277
[:SOURce<hw>]:BB:W3GPP:TRIGger:RMODE?.....	273
[:SOURce<hw>]:BB:W3GPP:TRIGger:SLENgth.....	274
[:SOURce<hw>]:BB:W3GPP:TRIGger:SLUNit.....	275
[:SOURce<hw>]:BB:W3GPP:TRIGger:SOURce.....	272
[:SOURce<hw>]:BB:W3GPP:TRIGger:TIME:DATE.....	273
[:SOURce<hw>]:BB:W3GPP:TRIGger:TIME:TIME.....	274
[:SOURce<hw>]:BB:W3GPP:TRIGger:TIME[:STATe].....	274
[:SOURce<hw>]:BB:W3GPP:TRIGger[:EXTernal]:DELay.....	275
[:SOURce<hw>]:BB:W3GPP:TRIGger[:EXTernal]:INHibit.....	275
[:SOURce<hw>]:BB:W3GPP:WAVeform:CREate.....	263
[:SOURce<hw>]:BB:W3GPP[:TRIGger]:SEQuence.....	271

# Index

## Symbols

(Mis-) use TPC for output power control	
DPCCH .....	136, 167, 292, 362
F-DPCH .....	295
2nd search code group .....	69
2nd Search Code Group .....	328
3GPP Version .....	46, 263
3i OCNS mode .....	26
4C-HSDPA Mode .....	181, 182
4C-HSPDA	
Reference Measurement Channel .....	256
8C-HSDPA Mode .....	181, 182

## A

Absolute Grant Scope .....	139
Absolute Grant Value Index .....	139
Accept	
Multi channel assistant .....	148
Predefined Settings .....	66
Accept copy .....	264
Access Slot .....	131
ACK Pattern	
AICH/AP-AICH .....	130
AP-AICH .....	285
HSUPA .....	141
Additional UE .....	67
Adjust	
HSDPA .....	94
Adjust ARB sequence length	
HS-DPCCH .....	187, 188
Adjust total power to 0 dB .....	59
Adjust Total Power to 0 dB .....	265
Advanced Mode	
HSDPA .....	94, 297
AICH Settings .....	130
AICH transmission timing	
PCPCH .....	237
AICH Transmission Timing	
PCPCH .....	394
PRACH .....	397, 405
Alternate HS-PDSCH Modulation .....	109
Alternate number of HS-PDSCH channelization codes ..	109
Always Use Redundancy Version 0 (HARQ)	
HSUPA FRC .....	204, 414
AP-AICH Settings .....	130
Application cards .....	13
Application notes .....	13
ARB sequence length	
PCPCH .....	238
Repeat structure after .....	227, 238
ARB sequence Length	
PRACH .....	227
ARB Settings .....	47
Arm trigger .....	50
Armed_Auto .....	49
Armed_Retrigger .....	49
Assignment Mode for UL-DTX .....	159
At Slot .....	86
Auto .....	49

## B

Base station default values .....	57, 263
Base station identification .....	69
Baseband C/D	
Disabled realtime functions .....	44
Binary channel bits per TTI .....	101
Binary Channel Bits per TTI .....	298
Binary Channel Bits/TTI (Nbin)	
HSUPA FRC .....	418
Bit error rate	
HSDPA H-Set .....	107
Bit Error Rate	
Enhanced DPCHs .....	123
Enhanced DPDCH UE1 .....	221
HSUPA FRC .....	205
Bit error state .....	205
Enhanced DPDCH UE1 .....	221
HSDPA H-Set .....	107
Bit Error state	
Enhanced DPCHs .....	122
Bit Error State	
Enhanced DPCHs .....	347
Enhanced DPDCH .....	435
HSDPA H-Set .....	349
HSUPA FRC .....	412
Bits per Frame	
DPDCH .....	118, 217, 431
Block Error Rate	
Enhanced DPCHs .....	123
Enhanced DPDCH UE1 .....	222
HSDPA H-Set .....	107, 349
HSUPA FRC .....	206
Block error state	
Enhanced DPCHs .....	123
Enhanced DPDCH UE1 .....	222
HSDPA H-Set .....	107
HSUPA FRC .....	206
Block Error State	
Enhanced DPCHs .....	348
Enhanced DPDCH .....	436
HSDPA H-Set .....	350
HSUPA FRC .....	413
Brochures .....	12
Burst Mode .....	89, 93
HSDPA .....	297
BxT .....	246, 268

## C

Channel Coding	
UE1 .....	216
Channel Coding State	
Enhanced P-CCPCH .....	342
UE1 .....	432
Channel Coding Type	
Enhanced P-CCPCH .....	113
P-CCPCH .....	342
Channel graph .....	78
Channel number .....	74
Channel Number	
DPDCH .....	171
E-DPDCH .....	208

- Channel P-CCPCH ..... 111
  - Channel power
    - Multi channel assistant ..... 147
  - Channel Power ..... 75
  - DPDCH ..... 169
  - Channel state ..... 77
    - Multi channel assistant ..... 148
  - Channel State
    - BS ..... 316
  - Channel table
    - DPCCH ..... 162
    - DPDCH ..... 168, 171, 446
    - E-DCH ..... 209
    - E-DPDCH ..... 206
  - Channel Table
    - E-DPDCH ..... 208, 447, 449
  - Channel type
    - Multi channel assistant ..... 146
  - Channel Type ..... 74
  - DPDCH ..... 171
  - E-DPDCH ..... 208
  - Channelization code ..... 75
    - DPCCH ..... 163
    - HS-DPCCH ..... 178
    - Multi channel assistant ..... 146
  - Channelization Code
    - DPDCH ..... 171, 382
    - E-DPCCH ..... 195
    - E-DPDCH ..... 208
  - Channelization code HS-SCCH (SF128) ..... 99
  - Channelization Code Offset ..... 58
  - Channelization code step
    - Multi channel assistant ..... 147
  - Chip Rate ..... 47, 267
  - Chip Rate Variation ..... 247
  - Clipping Level ..... 249, 266
  - Clipping Mode ..... 249, 267
  - Clipping Settings ..... 47
  - Clock Source ..... 55
  - Code domain conflict ..... 78, 79
  - Code domain ideal display ..... 79
  - Code tree of channelization codes ..... 79
  - Coding rate ..... 102
  - Coding Rate ..... 300
  - Coding rate (N<sub>inf</sub>/N<sub>bin</sub>)
    - HSUPA FRC ..... 201
  - Coding Rate (N<sub>int</sub>/N<sub>bin</sub>)
    - HSUPA FRC ..... 410
  - Coding state
    - PCPCH ..... 244
    - PRACH ..... 232
  - Coding State
    - PCPCH ..... 441
    - PRACH ..... 442
  - Coding Type ..... 117, 334
    - Enhanced DPDCH UE1 ..... 216
    - PCPCH ..... 244, 442
    - PRACH ..... 232, 442
  - Coding Type Enhanced
    - DPDCH ..... 432
  - Compatibility Mode
    - HS-DPCCH ..... 177
  - Composite CQI
    - HS-DPCCH ..... 187
  - Compressed Mode
    - BS ..... 326
  - Constellation version parameter b ..... 90, 92
  - Constellation Version Parameter b ..... 312
  - Control Power
    - PCPCH ..... 240
    - PRACH ..... 230, 398
  - Conventions
    - SCPI commands ..... 259
  - Convolution coder
    - BS1 ..... 121
    - UE1 ..... 220
  - Convolution Coder
    - UE1 ..... 441
  - Copy
    - Base Station ..... 58, 264
    - from Source ..... 58
    - User Equipment ..... 58, 264
  - Copy from Source ..... 264
  - Copying the data of a base or user equipment ..... 264
  - CQI
    - HS-DPCCH ..... 187, 194
  - CQI Length
    - HS-DPCCH ..... 190
  - CQI Type
    - HS-DPCCH ..... 185, 194
  - CQI Values
    - HS-DPCCH ..... 190
  - CQI1
    - HS-DPCCH ..... 187, 194
  - CQI2
    - HS-DPCCH ..... 187, 194
  - CQIs
    - HS-DPCCH ..... 187, 194
  - Crest factor ..... 66
    - Clipping ..... 266
  - Crest factor - timing offset ..... 76
  - Crest factor – Clipping ..... 247
  - Current ARB sequence length
    - HS-DPCCH ..... 187
  - Cut Off Frequency Factor ..... 247
- ## D
- Data
    - BS ..... 76, 286
  - Data config ..... 76
  - Data Power
    - PCPCH ..... 240
    - PRACH ..... 230, 399
  - Data rate matching
    - BS1 ..... 120
    - UE1 ..... 220
  - Data sheets ..... 12
  - Data source ..... 21
    - DPCCH ..... 134, 166
    - DPDCH ..... 172
    - E-DPDCH ..... 209
    - F-DPCCH ..... 143
    - HSUPA FRC ..... 199
    - Multi channel assistant ..... 147
    - PCPCH ..... 242
    - PRACH ..... 231
    - Transport channel ..... 119, 218
  - Data Source
    - DPDCH ..... 382
    - E-DCH ..... 410
    - E-DPDCH ..... 408
    - HS-PDSCH ..... 98
    - PCPCH ..... 387

PRACH .....	398
Transport Channel .....	338
DC-HSDPA Mode .....	181, 182
DCCH Dedicated Control Channel .....	115
DCCH On	
Enhanced DPCH .....	341
DCCH on enhanced DPCH .....	119
DCCH-Dedicated Control Channel .....	214
Default settings .....	46, 57, 263
All channels .....	73
BS .....	284
Channel table .....	73
HSDPA H-Set .....	73
Default Values User Equipment .....	57
Delay	
Marker .....	54
Trigger .....	52
Direction .....	344
Dynamic Power Control .....	126, 158
Distance .....	86
Diversity .....	70
BS .....	329
DL Frame Structure .....	84, 323
DL-UL timing offset	
DPCCH .....	164
Documentation overview .....	11
Down range .....	159
Dynamic Power Control .....	127
Downlink .....	47
DPCCH + DPDCH .....	151, 353
DPCCH Burst Length .....	157
DPCCH Settings .....	131
DTCH Dedicated Traffic Channel .....	115
DTCH On	
Enhanced DPCH .....	341
DTCH on enhanced DPCH .....	119
DTCH-Dedicated Traffic Channel .....	214
DTX cycle	
UL-DTX .....	156
DTX indication bits	
BS1 .....	121
DTX Indication Bits .....	339
Dynamic Power Control .....	153, 158
Direction .....	126, 158
DL .....	126
Down Range .....	344, 429
Power Step .....	345
Step .....	430
Up Range .....	344, 429
Dynamic Power Control Direction .....	428
BS1 .....	344
Dynamic Power Control Mode .....	126, 158
Dynamic range	
Dynamic Power Control .....	127, 159, 429
<b>E</b>	
E-AGCH Information Filed Coding .....	139
E-AGCH Settings .....	138
E-DCH TTI .....	139, 140, 212
HSUPA FRC .....	200, 418
E-HICH Settings .....	140
E-RGCH Settings .....	140
Enhanced Channels Coding .....	334
Enhanced DPCHs .....	330
Enhanced P-CPICH Pattern .....	110, 330
Enhanced Settings	
BS .....	74
P-CCPCH .....	111
P-CPICH .....	110
Error protection	
UE1 .....	220
Error Protection	
BS1 .....	121
UE1 .....	441
External Power Control	
BS1 .....	126
External Trigger Delay .....	52
<b>F</b>	
F-DPCH Settings .....	142
FBI Mode	
DPCCH .....	166, 358
PCPCH .....	241, 389
FBI pattern	
PCPCH .....	241
FBI Pattern	
DPCCH .....	166
Filter	
Type .....	246
Filter Parameter .....	246, 268
Filtering Settings .....	47
Filtering, Clipping, ARB Settings .....	245
Fixed reference Channel .....	198
Fixed Reference Channel .....	410
Fixed reference Channel (FRC)	
HSUPA FRC .....	198
Fixed Reference Channel (FRC)	
HSUPA .....	410
Force Channelization Code to I/O .....	384
E-DPDCH .....	421
Force Channelization Code to I/Q .....	170
E-DPDCH .....	207
FRC .....	198, 410
<b>G</b>	
Gap Distance	
BS .....	86
Gap Length .....	86
Generate Waveform .....	46
Getting started .....	11
<b>H</b>	
H-Set .....	93
Happy Bit	
E-DPCCH .....	196, 419
HARQ-ACK	
HS-DPCCH .....	182, 193
HARQ-ACK pattern	
HS-DPCCH .....	190
HSUPA FRC .....	204
HARQ-ACK Pattern	
HS-DPCCH .....	367
Help .....	12
Higher layer scheduling .....	84, 323
UE .....	356
HS-DPCCH Power .....	175
HS-PDSCH Modulation .....	101
HS-SCCH Type .....	95, 311
HSDPA H-Set settings .....	92

- HSDPA Mode ..... 89, 92  
 BS ..... 314
- HSDPA Settings  
 BS ..... 88
- HSUPA FRC ..... 196
- HSUPA settings ..... 138, 140
- I**
- Inactivity threshold ..... 156
- Information bit payload ..... 102  
 HSUPA FRC ..... 201
- Information Bit Payload ..... 299
- Information Bit Payload (Ninf)  
 HSUPA FRC ..... 416
- Insert errors ..... 107  
 HSUPA FRC ..... 205
- Insert Errors On  
 Enhanced DPCHs ..... 123, 346  
 Enhanced DPDCH ..... 435  
 Enhanced DPDCH UE1 ..... 221  
 HSDPA H-Set ..... 348  
 HSUPA FRC ..... 412
- Installation ..... 11
- Instrument help ..... 12
- Instrument security procedures ..... 12
- Inter TTI Distance ..... 90, 103  
 HSDPA ..... 314
- Inter-TTI distance  
 HS-DPCCH ..... 178
- Interleaver  
 P-CCPCH ..... 342
- Interleaver P-CCPCH ..... 113
- L**
- Layer  
 Bit error insertion ..... 123, 221
- Level reference  
 see Power reference ..... 60
- Link Direction ..... 47, 265
- Long Preamble Length ..... 156
- Long scrambling code ..... 152
- Long Scrambling Code  
 UE ..... 354
- M**
- Marker delay ..... 54
- Maximum information bitrate  
 HSUPA FRC ..... 198
- Message Length  
 PCPCH ..... 241, 389  
 PRACH ..... 230, 400
- Method for compressed mode ..... 84  
 BS ..... 84, 323  
 UE ..... 356
- MIMO ..... 70  
 BS ..... 329
- MIMO Mode  
 HS-DPCCH ..... 181, 190
- Mode  
 Dynamic Power Control ..... 126, 158  
 HARQ Simulation ..... 302  
 UE ..... 151, 353
- Mode (HARQ simulation) ..... 105
- Mode (HARQ)  
 HSUPA FRC ..... 204
- Modulation  
 BS ..... 91  
 E-DPDCH ..... 207, 421  
 HSUPA FRC ..... 199, 416
- Modulation data  
 BS ..... 76, 286
- Multi Channel Assistant ..... 146
- Multicode state  
 DPCCH ..... 133
- Multicode State  
 DPCCH ..... 288
- N**
- Nominal average information bitrate ..... 95
- Number of additional UE ..... 68, 351
- Number of configurable TTIs ..... 139
- Number of DPCH  
 Predefined Settings ..... 66
- Number of H-PDSCH channel codes ..... 99
- Number of H-PDSCH Channel Codes ..... 299
- Number of HARQ processes  
 HSUPA FRC ..... 200
- Number of HARQ Processes ..... 104
- Number Of HARQ Processes  
 HSUPA FRC ..... 415
- Number of intervals  
 HARQ-ACK ..... 182  
 PCI / CQI ..... 185
- Number of PI per Frame ..... 70, 327
- Number of TTIs  
 HS-DPCCH ..... 193
- O**
- OCNS ..... 71
- OCNS Mode ..... 71
- Offset  
 UL-DTX ..... 155
- Open loop transmit diversity ..... 70
- Open Loop Transmit Diversity ..... 326
- Open source acknowledgment (OSA) ..... 13
- Overall Symbol Rate  
 DPDCH ..... 170, 385  
 E-DPDCH ..... 207  
 UE1 ..... 217, 437
- Overall Symbol Rate RFC  
 HSUPA FRC ..... 199
- P**
- Pattern  
 BS ..... 76, 286
- Pattern Length  
 BS ..... 87
- PCI  
 HS-DPCCH ..... 187, 193
- PCPCH only ..... 151, 233, 353
- PCPCH settings ..... 233  
 Channel coding ..... 244  
 Graphical display ..... 235  
 Message part ..... 240  
 Preamble settings ..... 238
- PCPCH structure ..... 235



Pilot Length	
DPCCH .....	129, 133
S-CCPCH .....	129, 133
Postamble Length	
UL-DTX .....	157
Power	
BS .....	75
DPCCH .....	359
E-DPCCH .....	195, 419
E-DPDCH .....	209, 409
HS-DPCCH .....	177
Multi channel assistant .....	147
Power Control .....	158
BS1 .....	126
Power Control Grap .....	429
Power Control graph	
Ext. Power Control .....	159
Power Control Preamble Length	
PCPCH .....	240, 390
Power DPCCH	
DPCCH .....	163
Power Offset	
Additional UE .....	68
BS .....	85
Pilot DPCCH .....	137
TFCI DPCCH .....	138
TPC DPCCH .....	138
UE .....	85
Power Offset ACK	
HS-DPCCH .....	189
Power Offset ACK/ACK	
HS-DPCCH .....	192
Power Offset ACK/NACK	
HS-DPCCH .....	192
Power Offset CQI	
HS-DPCCH .....	186
Power Offset CQI Type A	
HS-DPCCH .....	193
Power Offset HARQ-ACK	
HS-DPCCH .....	184
Power Offset Mode	
BS .....	85, 325
UE .....	85, 325
Power Offset NACK	
HS-DPCCH .....	189
Power Offset NACK/ACK	
HS-DPCCH .....	192
Power Offset NACK/NACK	
HS-DPCCH .....	192
Power Offset PCI	
HS-DPCCH .....	186
Power reference .....	60
Power step .....	127, 158
DPCCH .....	168
Multi channel assistant .....	147
Power Step	
TPC DPCCH .....	363
Power step TPC	
F-DPCCH .....	145
Power Step TPC	
DPCCH .....	292
F-DPCH .....	296
Power step TPC - DPCCH	
DPCCH .....	136
PowMp	
PCPCH .....	236
PowMP .....	225
PowMpControl .....	225
PowMpData .....	225
PowPre .....	225
PCPCH .....	236
PRACH	
PowMP .....	225
PowMpControl .....	225
PowMpData .....	225
PowPre .....	225
PRACH only .....	151, 353
PRACH settings .....	222
Channel coding .....	231
Graphical display .....	224
Message part .....	229
Preamble settings .....	228
Preamble Length	
UL-DTX .....	157
Preamble Power	
PCPCH .....	239
PRACH .....	228, 400
Preamble Power step	
PCPCH .....	239
PRACH .....	228
Preamble Power Step	
PCPCH .....	390
PRACH .....	400
Preamble repetition	
PCPCH .....	239
PRACH .....	229
Preamble Repetition	
PCPCH .....	391
PRACH .....	401
Precoding weight pattern (w2) .....	91, 97
Precoding Weight Pattern (w2) .....	304, 313
Predefined H-Set .....	303
Predefined Settings	
Accept .....	279
Symbol Rate DPCH .....	279
Puncturing .....	84, 323
UE .....	356
<b>R</b>	
Raised Cosine	
see Cosine .....	246
Random seed .....	109
Randomly varying modulation .....	109
Randomly varying number of codes .....	109
Rate Matching Attribute	
BS1 .....	120
UE1 .....	220
Read out mode	
DPCCH .....	135, 167
F-DPCCH .....	144
Read out Mode	
PCPCH .....	243
Read Out Mode	
DPCCH .....	293, 364
F-DPCH .....	296
Read Out Mode PCPCH	
PCPCH .....	396
Realtime functions	
Disabled in Baseband C/D .....	44
Recall	
3GPP FDD settings .....	46
Redundancy version parameter .....	105, 106
Redundancy Version Parameter .....	304

- Redundancy Version Parameter Sequence ..... 305
- Reference measurement channel coding types ..... 117, 334
- Relative Grant Pattern ..... 141
- Release notes ..... 13
- Repeat PCPCH structure ..... 238
- Repeat PRACH structure ..... 228
- Reset all base stations ..... 57
- Reset All Base Stations ..... 263
- Reset All User Equipment ..... 57
- Retransmission Sequence Number
  - E-DPCCH ..... 195, 420
- Retrigger ..... 49
- RMS power ..... 60
- Roll Off ..... 246, 268
- RRC filter
  - see Root Cosine ..... 246
- S**
- S-CCPCH Settings ..... 128
- Safety instructions ..... 12
- Save
  - 3GPP FDD settings ..... 46
- Scrambling code
  - BS ..... 69
  - UE ..... 152
- Scrambling Code
  - UE ..... 354
- Scrambling Code Step ..... 68
- Scrambling mode
  - UE ..... 152
- Scrambling Mode
  - UE ..... 354
- Secondary cell
  - Active ..... 182
  - Enabled ..... 181
- Security procedures ..... 12
- Select Base Station ..... 59
- Select User Equipment ..... 59
- Sequence Length
  - ARB ..... 250
  - PCPCH ..... 237
- Service manual ..... 12
- Set to default ..... 46
  - BS ..... 284
  - Channel table ..... 73
  - HSDPA H-Set ..... 73
- SF2 ..... 84, 323
- SFN ..... 112
- SFN restart ..... 112
- Short scrambling code ..... 152
- Short Scrambling Code
  - UE ..... 354
- Show coding
  - PCPCH ..... 245
  - PRACH ..... 232
- Signal duration
  - Unit ..... 49
- Signal generation status ..... 49
- Signaling pattern ..... 104
- Signalling Pattern
  - BS ..... 308
- Signature
  - PCPCH ..... 240, 392
  - PRACH ..... 229, 402
- Signature Hopping Pattern Index ..... 141
- Single ..... 49
- Size of CRC ..... 337
  - BS1 ..... 120
  - UE1 ..... 220, 439
- Slot format ..... 75
  - 4C-HSDPA ..... 179
  - DPCCH ..... 164
  - Enhanced DPCH ..... 118
  - F-DPCCH ..... 142
  - Multi channel assistant ..... 149
  - PCPCH ..... 241
  - PRACH ..... 230
- Slot Structure
  - DPCCH ..... 131
  - F-DPCCH ..... 142
  - S-CCPCH ..... 128
- Spreading code generator (search code) ..... 21
- Spreading code number ..... 75
- Standard settings ..... 46
  - All channels ..... 73
  - BS ..... 284
  - HSDPA H-Set ..... 73
- Start channel No
  - Multi channel assistant ..... 146
- Start channelization code HS-PDSCH (SF16) ..... 99
- Start Delay m
  - HS-DPCCH ..... 177
- Start Offset
  - PCPCH ..... 394
  - PRACH ..... 226, 405
- Start Offset PCPCH - UE ..... 236
- State ..... 45, 330
  - Bit Error ..... 122
  - Block Error ..... 123
  - BS ..... 69
  - Channel Coding ..... 334
  - Channel coding enhanced DPCHs ..... 116
  - Channel Coding Enhanced P-CCPCH ..... 113
  - Clipping ..... 247
  - Compressed Mode ..... 357
  - DPDCH ..... 169, 385
  - Dynamic Power Control ..... 126, 345
  - E-DPCCH ..... 195, 420
  - E-DPDCH ..... 207, 422
  - Enhanced DPCH Channels ..... 114
  - Enhanced P-CCPCH ..... 111
  - HARQ ..... 414
  - HS-DPCCH ..... 176, 364
  - HSUPA FRC ..... 197, 417
  - Interleaver 1 ..... 121, 220, 340, 441
  - Interleaver 2 ..... 121, 220, 337, 436
  - Multicode ..... 133
  - Transport Channel ..... 341, 438
  - Transport channel enhanced DPCH ..... 119
  - UE ..... 151, 354
- State (HARQ)
  - HSUPA FRC ..... 204
- Step width power
  - Multi channel assistant ..... 147
- Stop channel No
  - Multi channel assistant ..... 146
- Store
  - 3GPP FDD settings ..... 46
- Stream 2 active pattern ..... 91, 97
- Stream 2 Active Pattern ..... 308, 313
- Structure Length
  - PRACH ..... 226

- Suggested ARB sequence length ..... 94  
 HS-DPCCH ..... 187
- Symbol rate  
 Multi channel assistant ..... 149
- Symbol Rate ..... 75  
 BS ..... 315  
 DPDCH ..... 171, 384  
 E-DPDCH ..... 208, 409  
 Enhanced DPCH ..... 118, 333  
 PCPCH ..... 241, 392  
 PRACH ..... 230, 402
- Symbol Rate DPCH ..... 279  
 Predefined Settings ..... 66
- System frame number ..... 112
- System information BCH ..... 112
- ## T
- Tau  
 DPCH ..... 141  
 E-HICH ..... 141  
 E-RGCH ..... 141
- Test Model ..... 281
- Test models  
 Downlink ..... 62  
 Uplink ..... 63
- Test Models (not standardized) ..... 281
- TFCI  
 DPCCH ..... 129, 133, 166  
 PCPCH ..... 242  
 PRACH ..... 231  
 S-CCPCH ..... 129, 133
- Time  
 Preamble - message part ..... 226  
 Preamble - Preamble ..... 226
- Time Delay  
 BS ..... 70  
 UE ..... 153
- Time Delay Step ..... 68
- Time Pre - MP ..... 394, 397, 405
- Time Pre - Pre ..... 395, 406
- Time Pre->MP ..... 237
- Time Pre->Pre ..... 237
- Time-based trigger  
 Date ..... 50  
 State ..... 50  
 Time ..... 50
- Timing offset  
 DL-UL DPCCH ..... 164  
 Multi channel assistant ..... 149
- Timing Offset ..... 76
- To Destination ..... 58, 264
- Total HS-PDSCH Power ..... 99
- Total power ..... 59
- Total Power ..... 265
- TPC data source  
 DPCCH ..... 134, 166  
 PCPCH ..... 242
- TPC Data Source  
 DPCCH ..... 361  
 F-DPCH ..... 293  
 PCPCH ..... 395
- TPC for output power control  
 F-DPCCH ..... 144
- TPC Mode  
 DPCCH ..... 166, 363
- TPC read out mode ..... 135  
 DPCCH ..... 167  
 F-DPCCH ..... 144
- TPC read out Mode  
 PCPCH ..... 243
- TPC Read Out Mode  
 DPCCH ..... 293, 364  
 F-DPCH ..... 296  
 PCPCH ..... 396
- Transmission direction ..... 47, 265
- Transmission Time Interval  
 E-DPCCH ..... 212  
 E-DPDCH ..... 212
- Transmit Diversity ..... 70, 326
- Transport block size  
 BS1 ..... 120  
 UE1 ..... 219
- Transport block size index ..... 102  
 HSUPA FRC ..... 201
- Transport Block Size Index ..... 309  
 HSUPA FRC ..... 417
- Transport block size reference ..... 102
- Transport Block Size Reference ..... 310
- Transport block size table ..... 102  
 HSUPA FRC ..... 200
- Transport Block Size Table ..... 310  
 HSUPA FRC ..... 417
- Transport blocks  
 BS1 ..... 120
- Transport Blocks  
 UE1 ..... 438
- Transport Channel  
 Enhanced DPCH ..... 119
- Transport time interval  
 BS1 ..... 120  
 UE1 ..... 219
- Trigger  
 Synchronize output ..... 51
- Trigger Delay ..... 52
- Trigger Mode ..... 49
- Trigger signal duration ..... 49
- Trigger source ..... 50
- Turbo coder  
 BS1 ..... 121  
 UE1 ..... 220
- Turbo Coder  
 UE1 ..... 441
- Type of Cell  
 HSUPA ..... 140
- ## U
- UE category  
 BS ..... 311  
 HSDPA ..... 95  
 HSUPA FRC ..... 198
- UE supports 64QAM ..... 101
- UE Supports 64QAM ..... 306
- UE\_DTX\_DRX\_Offset ..... 155
- UEID  
 A-EGCH ..... 139  
 BS ..... 99, 312
- UL DTX ..... 153, 155
- Up range ..... 159  
 Dynamic Power Control ..... 127
- Uplink ..... 47
- Use Channels needed for Sync of Mobile (UE) ..... 65, 280

Use Compressed Mode	
BS .....	326
UE .....	357
Use E-TFCI	
E-DPCCH .....	196
Use S-CCPCH .....	65
Use S-CPICH as phase reference .....	70
Use S-CPICH as Phase Reference .....	328
Use scrambling code	
BS .....	69
Use Scrambling Code	
BS .....	327
Use TFCI	
DPCCH .....	129, 133, 165, 290, 360
S-CCPCH .....	129, 133
Use UL-DTX .....	153, 155
User coding .....	117
UE1 .....	217
User Coding .....	433
User Data (DTX pattern)	
HSUPA FRC .....	202
User Data (DTX Pattern)	
HSUPA FRC .....	413
User Equipment default values .....	57
User manual .....	12

## V

Version .....	46, 263
Videos .....	13
Virtual IR buffer size (per HARQ process) .....	102
Visualizing data bits of DPDCH with an oscilloscope .....	170

## W

White papers .....	13
--------------------	----