

R&S®ATS1000

Antenna Test System

Instructions Handbook

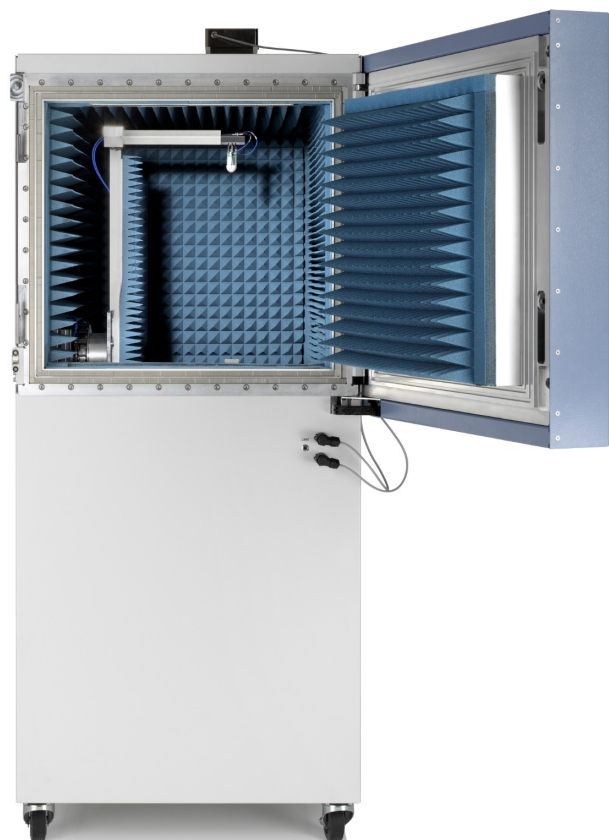

1179298302
Version 02

ROHDE & SCHWARZ
Make ideas real



Original instructions, referred to below as "this handbook".
It describes the following models of the antenna test system:

- R&S®ATS1000, Version 02, order no. 1532.1010K02
- R&S®ATS1000, Version 03, order no. 1532.1010K03

The antenna test system is also referred to as the "chamber" or the "product".

The software contained in this product uses several valuable open source software packages. For information, see the "Open Source Acknowledgment" document, which is available for download from the R&S ATS1000 product page at www.rohde-schwarz.com/product/ats1000 > Software.

Rohde & Schwarz would like to thank the open source community for their valuable contribution to embedded computing.

© 2021 Rohde & Schwarz GmbH & Co. KG
Mühlhofstr. 15, 81671 München, Germany
Phone: +49 89 41 29 - 0
Email: info@rohde-schwarz.com
Internet: www.rohde-schwarz.com

Subject to change – data without tolerance limits is not binding.

R&S® is a registered trademark of Rohde & Schwarz GmbH & Co. KG.

Trade names are trademarks of the owners.

1179.2983.02 | Version 02 | R&S®ATS1000

Throughout this handbook, the names of Rohde & Schwarz products appear without the ® symbol, e.g. R&S®ATS1000 is given as R&S ATS1000.

Contents

1	Introduction.....	7
1.1	Regulatory Information.....	7
1.1.1	CE Declaration.....	7
1.1.2	Korea Certification Class B.....	7
1.1.3	China RoHS Certification.....	8
1.2	Documentation Overview.....	8
1.2.1	Instructions Handbook.....	8
1.2.2	Configuration Manual.....	8
1.2.3	Data Sheets and Brochures.....	8
1.2.4	Open Source Acknowledgment (OSA).....	9
1.2.5	Application Notes, Application Cards, White Papers, etc.....	9
1.2.6	Help.....	9
1.3	Conventions.....	9
2	Safety.....	11
2.1	Intended Use.....	11
2.2	Residual Risks.....	11
2.3	Potentially Dangerous Situations.....	13
2.4	Warning Messages in This Handbook.....	15
2.5	Labels on the Chamber.....	15
3	Emergencies.....	17
3.1	Emergency Stop.....	17
4	Machine Overview.....	18
4.1	Interlock Systems.....	23
4.2	DUT Alignment Lasers.....	24
4.3	Positioner.....	25
4.3.1	Third-Party Positioning Equipment.....	26
5	Transportation, Handling and Storage.....	28
5.1	Moving the Chamber.....	28
5.2	Packing.....	29
5.3	Transport.....	32

5.4	Storage.....	32
6	Installation and Commissioning.....	34
6.1	Choosing the Operating Site.....	34
6.2	Unpacking and Checking.....	35
6.3	Installing the Chamber.....	37
6.4	Connecting to Power.....	38
6.5	Connecting to Control.....	39
6.6	Connecting Test Equipment.....	40
6.7	Testing Safety Systems.....	40
7	Operation.....	42
7.1	Activating the Chamber.....	42
7.2	Deactivating the Chamber.....	42
7.3	Operating the Door.....	43
7.3.1	Door Status.....	43
7.3.2	Referencing the Door's Lock.....	44
7.3.3	Opening the Door.....	45
7.3.4	Closing the Door.....	45
7.4	Placing a DUT in the Chamber.....	45
7.4.1	DUT Mass and Eccentricity.....	48
7.4.2	Metal DUT Holder Set.....	48
7.4.3	Telescopic Tube DUT Holder.....	50
7.4.4	Rohacell DUT Holder.....	50
7.4.5	PCB Holder Set.....	51
7.5	Connecting a DUT.....	54
7.6	Operating the Positioning System.....	55
7.6.1	Moving the Elevation Positioner.....	59
7.6.2	Moving the Azimuth Turntable.....	60
7.6.3	Combining the Elevation and Azimuth Movements.....	61
7.7	Preparing for Shift End.....	63
8	Inspection and Maintenance.....	64
8.1	Recommended Intervals.....	64
8.2	Regular Safety Inspections.....	64

8.3	Preparing the Chamber for Maintenance.....	65
8.4	Performing Maintenance Tasks.....	65
8.4.1	Daily Functional Check.....	65
8.4.2	Checking the Absorber.....	66
8.4.3	Cleaning.....	66
8.4.4	Lubricating the Turntable's Telescopic Tube.....	68
8.4.5	System Calibration.....	69
9	Troubleshooting and Repair.....	70
9.1	Chamber Troubleshooting.....	70
9.2	Positioner Troubleshooting.....	72
9.2.1	Positioner Loses Absolute Position.....	72
9.2.2	Unusual Noise from Positioner.....	72
9.3	Contacting Customer Support.....	73
10	Disabling and Scrapping.....	74
10.1	Taking Out of Commission.....	74
10.2	Disposal.....	75
	Glossary: List of Frequently Used Terms and Abbreviations.....	76
	Index.....	79

1 Introduction

This instructions handbook addresses every **user** of the **chamber** (also referred to as the **product**). To use the chamber safely, first read and understand this entire handbook. If you are unsure about a topic, ask your supervisor or contact Rohde & Schwarz customer support.

The instructions handbook helps you to use the chamber safely and efficiently during its entire lifecycle; installation, operation, maintenance and disabling. If you are only involved in one part of the lifecycle, focus on the chapter about that topic. But always get a deep understanding of the safety aspects described in **Chapter 2, "Safety"**, on page 11 before starting.

The chapter titles give a clear idea of the lifecycle stage and the tasks described. For example, if you are an **operator**, most activities intended for you are described in **Chapter 7, "Operation"**, on page 42. If tasks are restricted to certain roles, these roles are mentioned at the beginning of the chapter that describes the tasks. The **roles** are explained in the glossary.

Abbreviations and frequently used terms are explained in the glossary at the end of this handbook.

1.1 Regulatory Information

The following labels and the associated certificates declare conformance with legal regulations.

1.1.1 CE Declaration

 Certifies compliance with the applicable provisions of the Directive of the Council of the European Union. A copy of the CE declaration in English is at the beginning of the printed version of this handbook.

1.1.2 Korea Certification Class B



이 기기는 가정용(B급) 전자파 적합기기로서 주로 가정에서 사용하는 것을 목적으로 하며, 모든 지역에서 사용할 수 있습니다.

1.1.3 China RoHS Certification



Certifies compliance with the Chinese government's regulation on the restriction of hazardous substances (RoHS).

The chamber is built of environmentally sound materials. It is free of substances that are either restricted or prohibited by law.

1.2 Documentation Overview

This section provides an overview of the R&S ATS1000 user documentation. Unless specified otherwise, you find the documents on the R&S ATS1000 product page at:

www.rohde-schwarz.com/product/ats1000

1.2.1 Instructions Handbook

This handbook describes all operating modes and functions of the chamber. It also provides information on maintenance, interfaces and error messages.

The handbook does **not** describe the special activities required for permitted hardware reconfigurations of the chamber, which are described in the [Configuration Manual](#). Only an **expert user** who has read and understood the [Configuration Manual](#) is allowed to perform reconfigurations. Other users are limited to tasks described in the instructions handbook.

A printed copy of this handbook is included in the delivery and available at:

www.rohde-schwarz.com/manual/ats1000

1.2.2 Configuration Manual

Describes all permissible hardware reconfigurations and adjustments of the chamber.

These activities are restricted to the role of an **expert user** who has read and understood the [Configuration Manual](#) and who has all skills required for reconfiguring the chamber.

The configuration manual is available for registered users on the global Rohde & Schwarz information system (GLORIS):

gloris.rohde-schwarz.com > [Support & Services](#) > [Sales Web](#) > [Test and Measurement](#) > [Wireless Communication](#) > [ATS1000](#) > [Manuals](#)

1.2.3 Data Sheets and Brochures

The data sheet contains the technical specifications of the chamber. It also lists optional accessories and their order numbers.

The brochure provides an overview of the chamber and describes its specific features and characteristics.

See www.rohde-schwarz.com/brochure-datasheet/ats1000

1.2.4 Open Source Acknowledgment (OSA)

The open source acknowledgment provides verbatim license texts of the used open-source software.

See www.rohde-schwarz.com/software/ats1000

1.2.5 Application Notes, Application Cards, White Papers, etc.

These documents deal with special applications or background information on particular topics.

See www.rohde-schwarz.com/application/ats1000

1.2.6 Help

The help system that is embedded in the R&S RF Test Suite provides information for the R&S EMC32, R&S AMS32 and R&S WMS32 software packages. The R&S AMS32 software package communicates with the NCD controller. For help, navigate to this part of the help system.

1.3 Conventions

The R&S ATS1000 is also referred to as the "chamber" or the "product".

The following text markings are used throughout this handbook:

Convention	Description
[Keys]	Names of connectors, keys and knobs are placed between square brackets.
Filenames, commands, program code	Filenames, commands, coding samples and screen output are distinguished by their font.
Links	Clickable links are shown in blue font.
bold or <i>italic</i>	Highlighted text is shown in bold or italic font.
"quote"	Quoted text or terms are placed between quotation marks.



Tip

Tips are indicated as in this example and provide useful hints or alternative solutions.

**Note**

Notes are indicated as in this example and provide important additional information.

2 Safety

Products from the Rohde & Schwarz group of companies are manufactured in accordance with the highest technical standards. Follow the instructions provided throughout this handbook. Keep the product documentation nearby and make it available to other users.

Use the chamber only for its intended use and within its performance limits, as described in [Chapter 2.1, "Intended Use"](#), on page 11 and in the data sheet. Reconfigure or adjust the chamber only as described in the product documentation. Other modifications or additions can affect the safety of the product and are not permitted.

For safety reasons, only trained personnel are allowed to handle the chamber. Trained personnel are familiar with the safety measures and know how to avoid potentially dangerous situations while performing the assigned tasks.

If any part of the chamber is damaged or broken, stop using the chamber. Only service personnel authorized by Rohde & Schwarz are allowed to repair the chamber. Contact Rohde & Schwarz customer support at www.customersupport.rohde-schwarz.com.

- [Intended Use](#)..... 11
- [Residual Risks](#)..... 11
- [Potentially Dangerous Situations](#)..... 13
- [Warning Messages in This Handbook](#)..... 15
- [Labels on the Chamber](#)..... 15

2.1 Intended Use

The chamber is intended for radiation testing of electronic components and devices in industrial, administrative, and laboratory environments; see [Chapter 6.1, "Choosing the Operating Site"](#), on page 34. Use the chamber only for its designated purpose, as described in this handbook. Observe the operating conditions and performance limits stated in the data sheet. If you are unsure as to appropriate use, contact Rohde & Schwarz customer support.

2.2 Residual Risks

Despite the inherent safe design measures and the implemented safeguarding and complementary protective measures, residual risks remain due to the following:

Chamber is heavy

The weight of the chamber without accessories is approximately 350 kg. If the chamber falls on a person, it can cause potentially fatal injury.

Chamber is mobile

When the chamber is stationary, always lock its wheels. The chamber stands safely when on a hard, stable and level floor surface.

If the floor surface is not hard and stable, the chamber can tilt or even topple over. If the floor is not level and the wheels are not locked, the chamber can start rolling away. Due to its heavy weight, if the chamber starts to move in an uncontrolled manner, it can speed up quickly and cause potentially fatal injury to anyone crossing its path.

Door of the chamber is heavy

The chamber's center of gravity shifts when the door is opened. If the chamber is not standing securely, opening the door can cause the chamber to topple over, resulting in potentially fatal injury.

The door is approximately 0.99 m to 1.89 m above floor level. If the door is open, collision with it can cause severe injury, due to its inert mass and solid construction. Do not, therefore, leave the door open when the chamber is unattended.

Take care when opening or closing the door. Make sure that it does not collide with a person, especially with a sitting person's head.

Risk of crushing fingers when moving the door

When the door is slightly open, it is dangerous to insert fingers between the door and the body of the chamber, especially close to the door hinge. Closing the door or opening it further can crush fingers, potentially leading to the loss of limbs.

Positioner moves with high torque

As long as the door of the chamber is open, the door interlock system prevents the positioner from moving. Touching the moving positioner causes severe injuries, like shearing off arms, hands or fingers. Therefore, never disable or bypass the interlock. Also, take the following safety measures before opening the door of the chamber:

- Stop the positioner before you open the door.
See "[To stop a positioner movement](#)" on page 57.
- As long as the door is open, do not initiate any positioner movement.

Class 2 lasers inside the chamber

The risks and safety measures are described in [Chapter 2.5, "Labels on the Chamber"](#), on page 15.

Electrically powered

The risks, requirements for installation and safety measures are described in "[Connecting to power](#)" on page 14.

2.3 Potentially Dangerous Situations

Potentially dangerous situations can occur during the following activities.

Transport

Wear appropriate protective clothing that complies with the local rules and regulations. If you are unsure of which equipment to use, ask your safety officer. For example, safety footwear prevents your toes being crushed under the chamber's wheels. Therefore, always wear safety footwear with toe cap when moving the chamber.

Always close and lock the door before moving the chamber, even if it is only for a short distance. If the door is unlocked while moving the chamber, the door can swing open or close. It can crush your fingers.

For short distances over hard, stable and level floor surfaces, you can move the chamber on its wheels. Select the transport route with care. Consider the weight and the dimensions of the chamber. Move the chamber with the aid of at least one other person. Hold the chamber at its rear handles or at the solid parts of the walls.

If you need to move the chamber up or down a slope, increase the number of helpers according to the steepness of the slope.

For longer distances or if the floor is not suitable for moving the chamber on its wheels, use lifting or transporting equipment such as lift trucks and forklifts. Do not attach any lifting gear to the top of the chamber. The caps that seal openings on the top of the chamber have to remain in place. The chamber is not suited structurally for carrying its own weight when suspended from above. Follow the instructions provided by the equipment manufacturer.

When loading or unloading the chamber into or from a truck, make sure that the tail-gate lift can support the weight of the chamber.

For detailed instructions, see [Chapter 5.1, "Moving the Chamber"](#), on page 28.

Setting up

The floor at the operating site must meet the following requirements:

- Capable of carrying at least 500 kg/m².
- Level - flat and horizontal with a deviation of maximum 1° to prevent unintentional movement of the chamber or of the door.
- Hard - at least the hardness of wood or industrial rubber flooring, preferably concrete or metal. If the floor is too soft, one or more wheels can sink into the floor and the chamber can topple over, causing potentially fatal injury.

Ensure that the chamber is accessible from every side. Avoid any impact, vibration and mechanical stress to the chamber.

When you have finished moving the chamber, lock the wheels to prevent unintentional movement.

Route cables carefully and ensure that nobody can trip over loose cables. Avoid running cables over the floor. If that is not possible, protect cables on the floor using bridges, so that you do not wheel the chamber directly over cables if you move it.

For detailed instructions, see [Chapter 6, "Installation and Commissioning"](#), on page 34.

Connecting to power

The chamber is an overvoltage category II product. Connect it to a fixed installation used to supply energy-consuming equipment such as household appliances and similar loads. Bear in mind that electrically powered products pose risks, such as electric shock, fire and potentially fatal injury.

Take the following measures for your safety:

- Before connecting the chamber to a power source (your mains), ensure that this source matches the voltage and frequency range indicated in the data sheet.
- Only use the power cable that is delivered with the chamber. It complies with country-specific safety requirements.
- Only insert the power cable's plug into an outlet with protective conductor terminal.
- Only use intact cables and route them carefully so that they cannot be damaged. Check the power cables regularly to ensure that they are undamaged.
- Only connect the chamber to a power source with a fuse protection of maximum 20 A.
- Ensure that you can disconnect the power supply unit from the power source at any time. Pull the power plug to disconnect the chamber. The power plug must be easily accessible.
- Install an easily accessible panic button (power-off switch, not included in the delivery) for interrupting the power source to the chamber.

Operating the door

The risks when handling the door are described in ["Door of the chamber is heavy"](#) on page 12 and ["Risk of crushing fingers when moving the door"](#) on page 12.

Open and close the door by its handle. Do not touch other parts of the door. When you push the [LOCK / UNLOCK] button, the automatic door locking mechanism is activated. It pulls the door tightly against the chamber with great force in order to ensure effective sealing.

Establish safety rules for operating the door to ensure that nobody gets their fingers caught between the door and the body of the chamber.

Use the chamber as configured by Rohde & Schwarz. Never tamper with its safety installations.

For detailed instructions, see [Chapter 7.3, "Operating the Door"](#), on page 43.

Maintenance

Carry out the maintenance tasks as required, to ensure that the chamber continues to function properly and maintain the safety of all users. For detailed instructions, see [Chapter 8, "Inspection and Maintenance"](#), on page 64.

Cleaning

See [Chapter 8.4.3, "Cleaning"](#), on page 66.

2.4 Warning Messages in This Handbook

A warning message refers to a risk or danger that you need to be aware of. The signal word indicates the severity of the safety hazard and how likely it will occur if you do not follow the safety precautions.

WARNING

Potentially hazardous situation. Could result in death or serious injury if not avoided.

CAUTION



Potentially hazardous situation. Could result in minor or moderate injury if not avoided.

NOTICE

Potential risks of damage. Could result in damage to the supported product or to other property.

2.5 Labels on the Chamber

Labels with the following symbols indicate areas of risk on the chamber. In addition, sections in this chapter which describe a specific risk are marked with the associated symbol in the margin. The symbols have the following meaning:

Symbol	Explanation
	Potential hazard Read the product documentation to avoid personal injury or product damage.
	Laser beam Chamber contains a class 2 laser Avoid exposure to direct or reflected laser beam. Staring directly into the beam can cause eye damage.
	Disposal Do not dispose of the chamber in normal household waste. See Chapter 10, "Disabling and Scrapping" , on page 74.

The labels providing regulatory information are described in [Chapter 1.1, "Regulatory Information"](#), on page 7.

Text labels are described in [Chapter 4, "Machine Overview"](#), on page 18.

3 Emergencies

Potential emergencies can result from failure of the interlock, which prevents the positioner from moving when the door is open. If the interlock fails and the positioner moves while the door is open, use the [Emergency Stop](#).

3.1 Emergency Stop



To stop the chamber's positioner quickly at any time, interrupt the electric power source.

To interrupt the electric power source

1. Hit the panic button that interrupts the power source.
See "[Power connection requirements](#)" on page 38.
2. If no panic button is installed, do one of the following:
 - Pull the power plug out of the mains power socket.
 - Pull the C19 connector out of the power supply unit [A221] at the rear of the chamber.
See [Figure 4-5](#).

Interrupting the electric power source has the following effects:

- The positioner stops moving immediately.
- The door's [LOCK / UNLOCK] button is no longer lit.
If the door was unlocked before the electric power source was interrupted, the button light already has gone out.
- The door's locking system is de-energized, you cannot lock or unlock the door.
- The power source to the chamber's alignment lasers is interrupted.
- The power source to any connected test instruments is interrupted only if the panic button has been configured to switch off these instruments as well.

To reactivate the chamber, proceed as described in [Chapter 7.1, "Activating the Chamber"](#), on page 42.

4 Machine Overview

This chapter describes the components of the chamber. The function and use of these components is described in [Chapter 7, "Operation"](#), on page 42.

Accessories for the chamber are described in the [Configuration Manual](#).

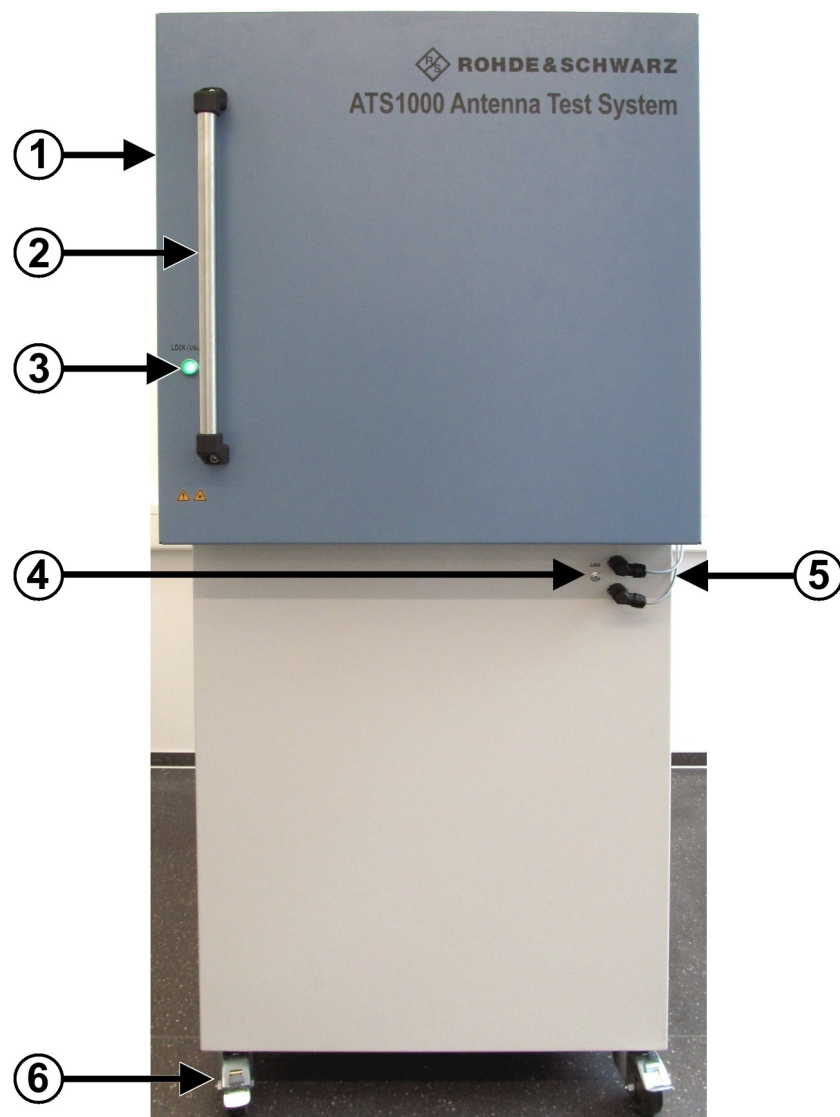

Figure 4-1: Front view of the R&S ATS1000

- 1 = Door
- 2 = Door handle
- 3 = Door [LOCK / UNLOCK] button
- 4 = [Laser] on/off button
- 5 = Laser power cables and connectors
- 6 = Four wheels with brakes (see [Chapter 5.1, "Moving the Chamber"](#), on page 28)

The door (labeled 1 in [Figure 4-1](#)) provides access to the chamber's interior.

The door handle (2) is used to open and close the door manually, but does not lock and unlock the door.

The [LOCK / UNLOCK] button (3) operates the electrically powered door locking and unlocking system. See [Chapter 7.3, "Operating the Door"](#), on page 43. The green light in the button indicates that the door is locked and the chamber is in a state ready for measurements.

Opening the door switches on the light in the chamber's ceiling and releases the interlocks, see [Figure 4-2](#).

The [Laser] button (4) switches the DUT alignment lasers in the chamber on or off; see [Chapter 4.2, "DUT Alignment Lasers"](#), on page 24. The button is located next to the connectors of the power cables (5) for the two laser boxes; see [Figure 4-3](#).

The four wheels (6) of the chamber have brakes that you can engage or release with the tip of your foot. See [Chapter 5.1, "Moving the Chamber"](#), on page 28.

When the door (1) is open as in [Figure 4-2](#), you can access the chamber's interior to insert and connect a DUT. In the interior, an **expert user** can configure the DUT holder, align the positioners and exchange the measurement antenna. The interior has the following features:

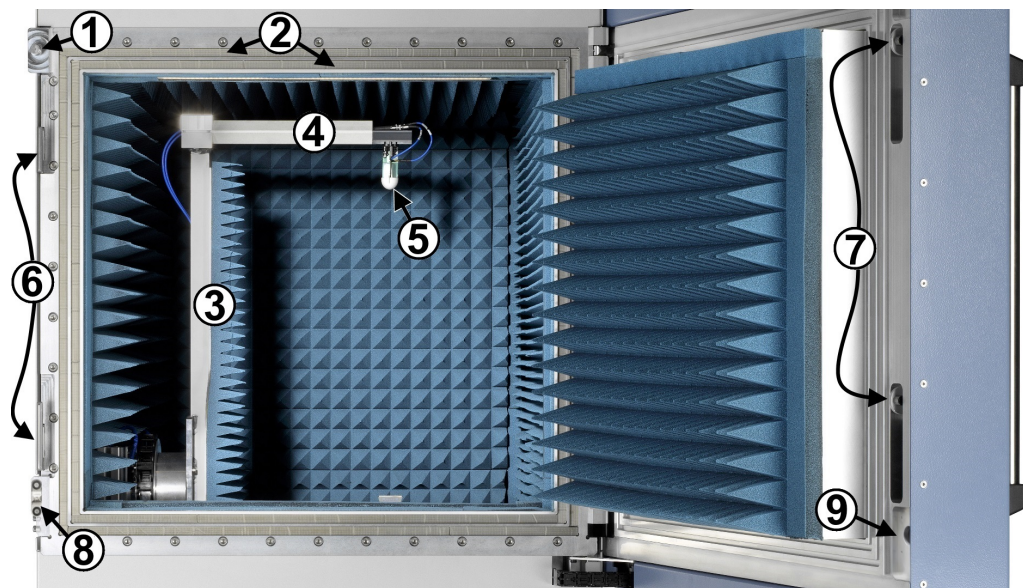

Figure 4-2: Front view of the R&S ATS1000

- 1 = Upper interlock (male interlock key) for controlling the door locking mechanism
- 2 = Two door gaskets in recessed grooves
- 3 = Antenna elevation positioner arm
- 4 = Antenna boom
- 5 = Antenna R&S TC-TA85CP (order no. 1531.8627.02)
- 6 = Door locking pegs
- 7 = Door locking latches (can engage with pegs)
- 8 = Lower interlock (male interlock key) for controlling movement of the positioners and turntable
- 9 = Lower interlock (keyhole in the door)

The upper interlock (1, see also [Figure 4-6](#)) controls the door locking mechanism. You cannot lock the door while it is still open. Therefore, close the door and push the [LOCK / UNLOCK] button to operate the door locking mechanism.

The twin polymeric gasket (2) has a conductive nickel coating to prevent RF radiation entering and leaving the chamber. Avoid touching or soiling the gasket. It is highly elastic to ensure a long service life over many opening and closing cycles. For maintenance intervals of the gasket, see [Chapter 8.1, "Recommended Intervals"](#), on page 64.

The DUT azimuth turntable (not shown here) and the antenna elevation positioner arm (3) can rotate as described in [Chapter 7.6, "Operating the Positioning System"](#), on page 55. At the arm's end, the boom (4) is designed to carry a maximum load of 0.1 kg. It holds the R&S TC-TA85CP measurement antenna (5). Always handle this delicate antenna with extreme care. Avoid subjecting it to mechanical force. Do not disconnect or reconnect the antenna.

When the door is locked, the recessed latches (7) move down to engage with the protruding pegs (6).

The lower interlock (8 and 9, see also [Figure 4-7](#)) controls the movement of the positioners. You cannot move the positioners while the door is still open. Therefore, close and lock the door so that the lower interlock enables the positioners.

Side and rear panels

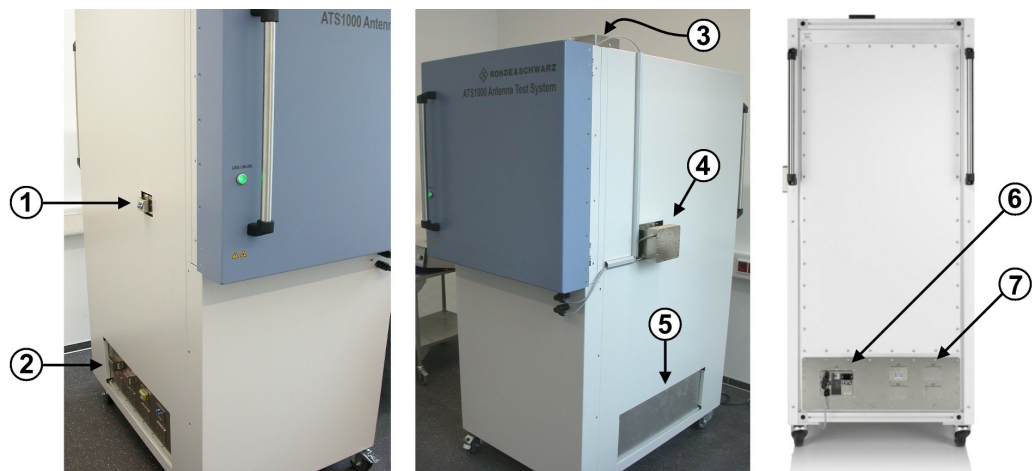

Figure 4-3: Left, right and rear view of the R&S ATS1000

- 1 = RF connectors [A111] for the test antenna; see [Feedthroughs on the left panel](#)
- 2 = Feedthroughs [A121] to [A134] on the left panel; see [Feedthroughs on the left panel](#)
- 3 = Top alignment laser box
- 4 = Right-hand alignment laser box [A311]
- 5 = Service panel
- 6 = Power feedthrough [A221] on the rear panel; see [Feedthroughs on the rear panel](#)
- 7 = Feedthroughs [A222] to [A233] on the rear panel; see [Feedthroughs on the rear panel](#)

Feedthroughs (1, 2, 6 and 7) allow control or RF signals to be fed through the wall to antennas or to other equipment in the chamber. Do not exchange the feedthroughs and connected cables on the side and rear panels. The internal cabling inside the

chamber is configured at the factory. Feedthroughs must, therefore, always be installed by the manufacturer only. If you want to exchange or add feedthroughs, contact Rohde & Schwarz [service](#) or your sales representative. The available feedthrough types are described in the [Configuration Manual](#).

Only an [expert user](#) is allowed to connect or disconnect cables at RF feedthroughs. Every [user](#) is allowed to connect or disconnect cables at other feedthroughs, like LAN, USB, D-Sub and fiber-optic feedthroughs.

Only an [expert user](#) is allowed to remove, mount or open the laser boxes (3 and 4), to align the lasers, and to use the lasers for aligning the positioner axes.

Only Rohde & Schwarz [service personnel](#) is allowed to open the service panel (5).

Feedthroughs on the left panel

The following feedthroughs are installed by default on the left panel of the chamber:

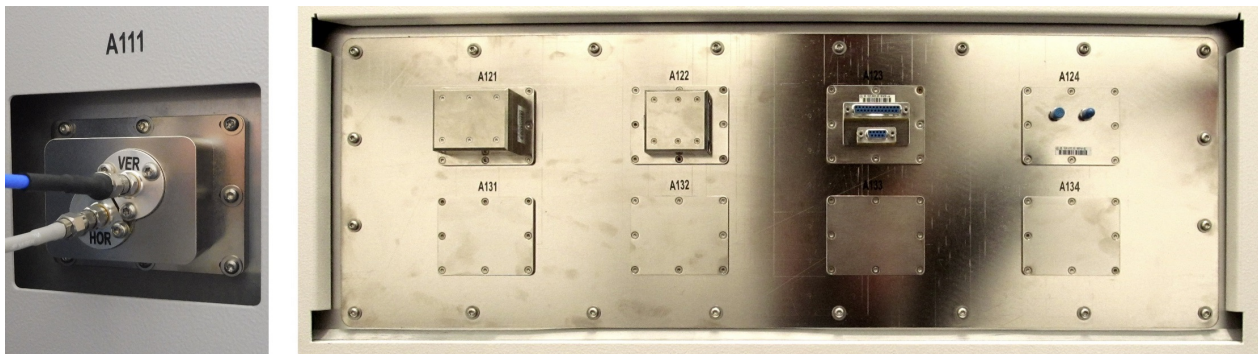

Figure 4-4: Feedthroughs on the chamber's left panel (left when viewed from the front)

Left = Twin RF feedthrough [A111] (= top row), with measurement cables connected for vertical [VER] and horizontal [HOR] polarization

Right = 8 factory-configurable feedthroughs on the lower left panel (= middle and lower row)

Table 4-1: Feedthroughs on the left panel

Position	1st column	2nd column	3rd column	4th column
Top row	[A111], reserved for the two RF ports that feed RF test signals through the rotational axis of the antenna elevation positioner arm			
Middle row	[A121] Standard configuration: LAN feedthrough	[A122] Standard configuration: USB feedthrough	[A123] Standard configuration: D-Sub feedthrough	[A124], standard configuration: Right: not connected Left: to DUT on azimuth turntable, feedthrough depends on selected RF cable set, either for 40 GHz or for 50 GHz. <ul style="list-style-type: none"> For 40 GHz: 2.92 mm RF feedthrough For 50 GHz: 1.85 mm RF feedthrough
Lower row	[A131] Standard configuration: Blinding plate	[A132] Standard configuration: Blinding plate	[A133] Standard configuration: Blinding plate	[A134] Standard configuration: Blinding plate

Feedthrough [A111] (left in [Figure 4-4](#)) is exclusively reserved for the two RF cables of the test antenna. As these cables are (and must be) fed through the rotational axis of the positioner arm, no other feedthrough can be mounted at position [A111].

Openings that are not used by optional RF-filtered feedthroughs are covered with metal blinding plates.

Feedthroughs on the rear panel

The following feedthroughs are installed by default on the rear panel of the chamber:

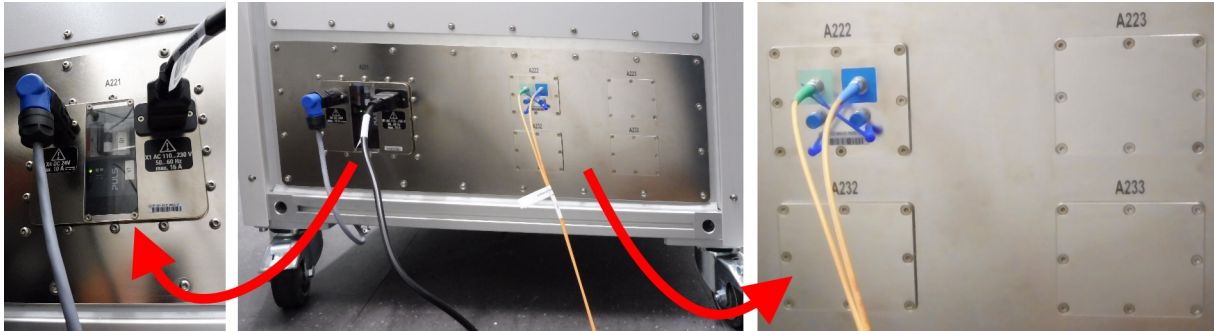

Figure 4-5: Feedthroughs on the chamber's rear panel

Left = Integrated R&S TS-F230V power supply unit [A221]
 Center = View of the whole rear feedthrough panel
 Right = Four factory-configurable feedthroughs on the rear panel

Table 4-2: Feedthroughs on the rear panel

Position	1st column	2nd column	3rd column
Upper row	[A221] Reserved for power only	[A222]; standard configuration: Twin fiber-optic feedthrough for positioner and turntable control	[A223]; standard configura- tion: Blinding plate
Lower row	No feedthrough available	[A232]; standard configuration: Blinding plate	[A233]; standard configura- tion: Blinding plate

The RF-filtered power supply unit [A221] has a 24 V DC output connector and an automatic fuse with earth leakage circuit breaker (ELCB) behind a glass cover panel. For the circuit breaker, see also [Chapter 9, "Troubleshooting and Repair"](#), on page 70.

In [Figure 4-5](#), position [A222] is fitted by default with a fiber-optic feedthrough that feeds two FO cables, for controlling the antenna positioner and the DUT turntable, through the chamber wall.

Openings that are not used by optional feedthroughs are covered with metal blinding plates.

Openings in the right panel

On the right-hand side of the chamber, there is an external box (labeled 4 in [Figure 4-3](#)). This box with label [A311] contains the horizontal alignment laser. Note that the laser's opening in the chamber wall cannot be used for mounting a feedthrough.

Only Rohde & Schwarz [service personnel](#) are allowed to open the service panel (labeled 5 in [Figure 4-3](#)). If the R&S ATS-TEMP climate option for DUT testing at extreme temperatures is installed in the chamber, its hot/cold air supply and exhaust hoses connect to the right service panel (5).

Table 4-3: Text labels printed on the chamber

Text label	Meaning
[LOCK / UNLOCK]	Button for locking and unlocking the door
[Laser]	Button for switching the laser on and off; see Chapter 4.2, "DUT Alignment Lasers" , on page 24
[Axxx]	Numbered feedthrough panel
[HOR]	SMA feedthrough for horizontal antenna polarization; see SMA / SMP connector
[VER]	SMA feedthrough for vertical antenna polarization; see SMA / SMP connector
[remove before operating]	Label on the turntable's crank that advises you to remove the crank (Figure 7-3) before operating the positioners.

- [Interlock Systems](#).....23
- [DUT Alignment Lasers](#).....24
- [Positioner](#).....25

4.1 Interlock Systems

The chamber has two interlock systems:

- Door interlock, uses the upper interlock key
- Positioner interlock, uses the lower interlock key

The door locking mechanism and the positioners are enabled only if the interlocks send positive signals (door closed).

Prerequisite: the electrical power supply unit of the chamber is connected to mains power.

Door interlock



Figure 4-6: Upper interlock key for the door locking mechanism

- 1 = Male upper interlock key
- 2 = Female upper interlock keyhole

The upper interlock system prevents the door locking mechanism from assuming the locked position while the door is still open, which can lead to equipment damage.

Positioner interlock

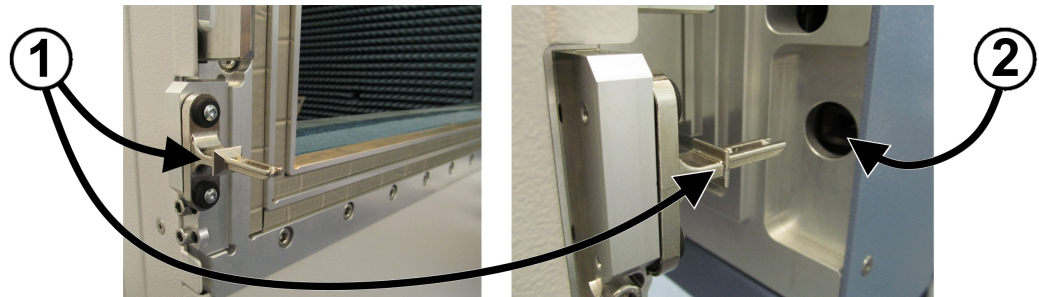

Figure 4-7: Lower interlock key for the positioners

- 1 = Male lower interlock key
- 2 = Female lower interlock keyhole

The lower interlock system stops the positioners from moving while the door is open, which can lead to personal injury.



This "open-door" icon in the NCD controller shows the interlock state:

- If the icon is visible, it indicates that the door is open and the interlock is stopping the positioners from moving.
- If the icon is not visible, the door is closed and the interlock does not stop the positioners from moving.

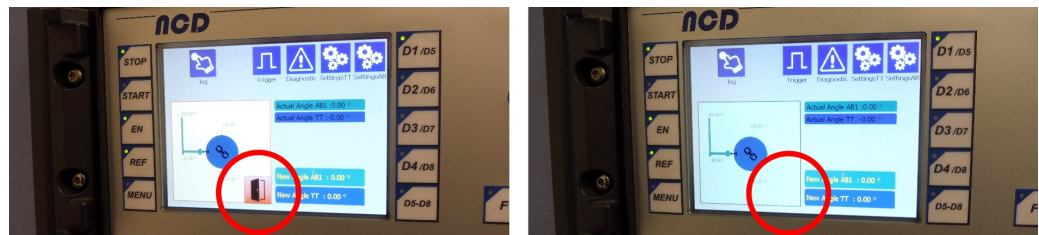

Figure 4-8: Interlock symbol in the positioner controller display

- Left = Door is open, interlock is activated, positioners cannot move
- Right = Door is closed, interlock is released, positioners can move

4.2 DUT Alignment Lasers

The lasers are functional only when the door is open.

The [Laser] button on the front panel switches the alignment lasers on and off:

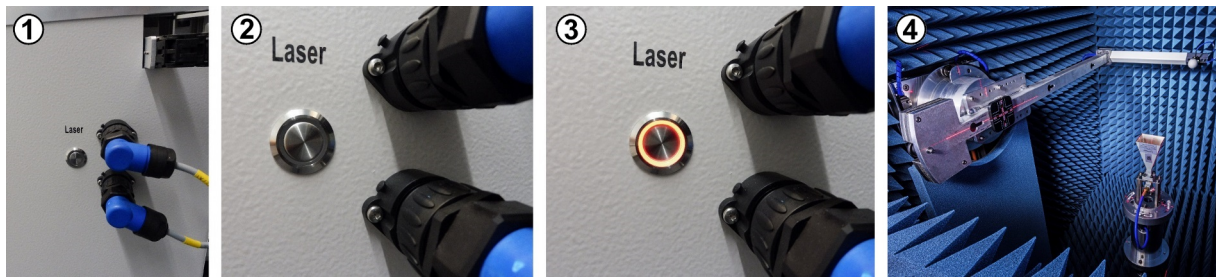

Figure 4-9: Switching on the alignment lasers

- 1 = Location of the [Laser] button
- 2 = Lasers "off"; button not lit and in unlatched position
- 3 = Lasers "on"; button lit and in latched (depressed) position
- 4 = View inside the chamber with alignment lasers switched on

You can use the laser crosshairs for repeatable positioning of your DUTs inside the chamber; see [Chapter 7.4, "Placing a DUT in the Chamber"](#), on page 45.

Only an **expert user** is allowed to remove, mount or open the laser boxes (labeled 3 and 4 [Figure 4-3](#)), and to align the lasers relative to the positioner axes.

4.3 Positioner

The 3D positioner in the chamber consists of an antenna elevation arm (labeled 1 in [Figure 4-10](#)) and a turntable (2). These two axes define 2 degrees of freedom of the 3D tilt-tilt positioner. The 3rd degree of freedom is the altitude at which you mount your DUT on a DUT holder on the manually height-adjustable turntable.

For typical measurement scenarios, we recommend centering your DUT on the intersection of the two axes. Locking the third dimension to a fixed altitude reduces the actively used degrees of freedom to two.

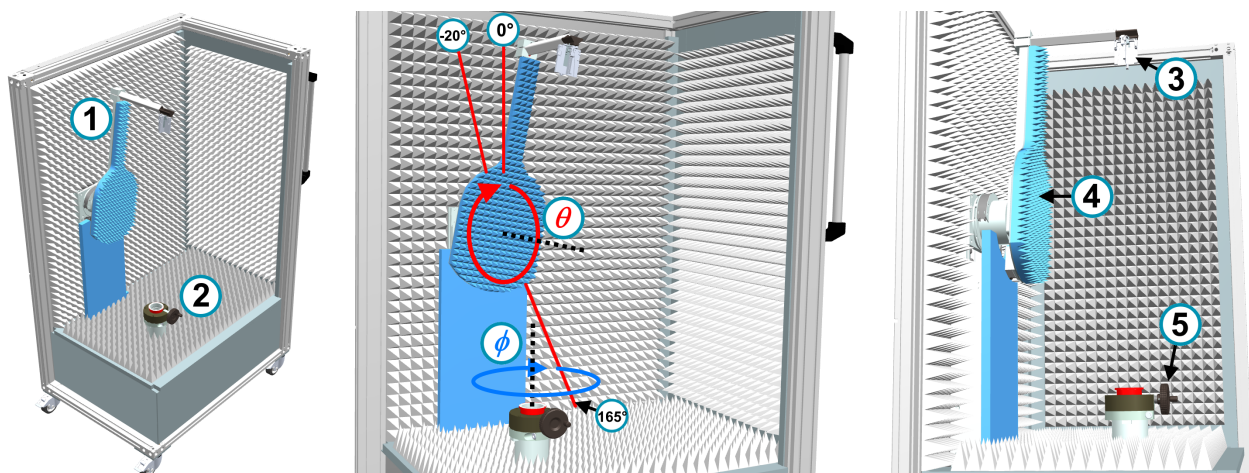

Figure 4-10: Interior view of the chamber (door, right wall and ceiling not shown)

- 1 = Antenna elevation arm; see [Chapter 4.3.1, "Third-Party Positioning Equipment"](#), on page 26
- 2 = Azimuth turntable; see [Chapter 4.3.1, "Third-Party Positioning Equipment"](#), on page 26
- 3 = Measurement antenna, mounted at the end of the antenna boom
- 4 = Guitar-shaped absorber panel on the antenna arm
- 5 = Crank wheel for lifting the turntable and a DUT holder mounted on it; remove crank wheel before moving the positioner
- φ = Azimuth angle "phi"; the blue arrow's direction indicates positive rotation of the φ axis
- θ = Elevation angle "theta"; the red arrow's direction indicates positive rotation of the θ axis
- 0° = Zenith position of the measurement antenna
- 20° = Maximum negative angle of front rotation of the antenna arm
- 165° = Maximum positive angle of rear rotation of the antenna arm

For mounting DUT fixtures and DUTs, see [Chapter 7.4, "Placing a DUT in the Chamber"](#), on page 45.

For operating the positioner, see [Chapter 7.6, "Operating the Positioning System"](#), on page 55.

4.3.1 Third-Party Positioning Equipment

The chamber's positioning equipment is manufactured by maturo GmbH. It comprises the following:

- Elevation positioner (antenna arm)
- Azimuth positioner (turntable)
- "NCD" positioning equipment controller

4.3.1.1 Risk Assessment of the Original Manufacturer

This assessment refers to the positioners in stand-alone operation.

Danger from mechanical energy

Caused by the movements of parts of the system, there is a risk of crushing as well as drawing-in hazard during operation. The defined area of risk must not be entered. While the system is stationary, there is a risk of impact as well as tripping hazard.

4.3.1.2 Integration in the Chamber

The positioners are integrated in the chamber. Safety measures are in place to prevent any danger arising from moving parts; you can only operate the positioners with the door of the chamber closed. This measure eliminates the crush and drawing-in hazard during operation. See ["Positioner moves with high torque"](#) on page 12.

4.3.1.3 Technical Data

The technical data as provided by the original manufacturer is given below.

Azimuth positioner (turntable)

Diameter cover plate	80 mm
Material cover plate	Aluminum
Load capability / Distance of main emphasis to the center	10 kg / 25 mm
Height of rotating axis	adjustable from 495 mm to 375 mm below rotating axis of Elevation Positioner
Positioning accuracy	< 0.03°
Rotating angle	limited by energy chain, Optional without energy chain endless

Elevation positioner (antenna arm)

Antenna arm with height precision (HP)

Distance antenna support to center	575 mm, 550 mm, 525 mm 500 mm, depending on position of fixing
Load capability	0.1 kg
Positioning accuracy	< 0.03°
Rotating angle	+ 165°, 10°, optional ±165°
Material antenna arm	Aluminum, reinforced fibreglass, PVC-U
Material Absorber plate	wood
Drive unit	Servomotor
Connection to Controller	Fiber-optic lines glass
Remote control via	LAN
Current consumption	max. 16 A
Voltage	230 V, 50/60 Hz, 1-phase
Temperature range	+5 °C to +35 °C, the room temperature will have influence to the positioning accuracy
Total weight	ca. 50 kg

5 Transportation, Handling and Storage

Familiarize yourself with residual risks and potentially dangerous situations.

See [Chapter 2.2, "Residual Risks"](#), on page 11 and [Chapter 2.3, "Potentially Dangerous Situations"](#), on page 13.

• Moving the Chamber	28
• Packing	29
• Transport	32
• Storage	32

5.1 Moving the Chamber

The chamber weighs approximately 350 kg and is therefore too heavy to be lifted or carried by persons. However, the chamber has wheels, which allow it to be moved on hard, stable and level floor surfaces.

When lifting the chamber, always use lifting equipment and follow the instructions provided by the equipment manufacturer. Do not attach any lifting gear to the top of the chamber; see also ["Transport"](#) on page 13.

Before moving

1. **WARNING!** The door of the chamber is heavy and can move. See ["Door of the chamber is heavy"](#) on page 12 and ["Risk of crushing fingers when moving the door"](#) on page 12.

Make sure that the door of the chamber is locked securely before you move the chamber. If the door is not locked, lock it as described in [Chapter 7.3.4, "Closing the Door"](#), on page 45.

2. Disconnect the chamber from its power source.
3. Disconnect the chamber from devices that are not attached to the chamber.
4. If you need to move the chamber through a door, do the following:
 - a) Measure whether the chamber fits through the door.
 - b) Consider the protruding laser boxes on the right panel and on top of the chamber (items 3 and 4 in [Figure 4-3](#)).
 - c) If the chamber only fits through the door without the laser boxes, contact an [expert user](#). Only an [expert user](#) can remove the laser boxes as described in the [Configuration Manual](#).

Correct moving

1. **WARNING!** The chamber is heavy. See ["Chamber is heavy"](#) on page 11 and ["Transport"](#) on page 13.

Unlock the wheels:

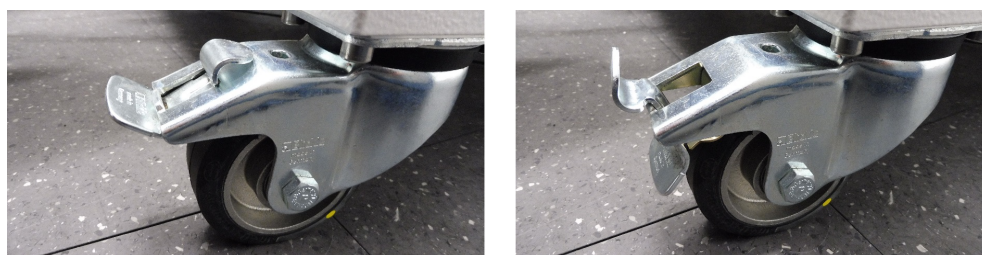

Figure 5-1: Wheel with brake

Left = Brake is released, wheel can move
Right = Brake is engaged, wheel cannot move

2. For short distances over hard, stable and level floor, move the chamber on its wheels with the aid of at least one other person.
 - a) Select the transport route with care. It must be free of obstacles, for example unprotected cables. Consider the weight and the dimensions of the chamber.
 - b) Hold the chamber at its rear handles or at the solid parts of the walls.
 - c) Keep your hands and feet keep away from the wheels. Severe injury is likely if one of the wheels rolls over a part of your body.
3. For longer distances or if the floor is not suitable for moving the chamber on its wheels, use lifting or transporting equipment such as lift trucks and forklifts. For further instructions, see [Chapter 5.3, "Transport"](#), on page 32.
4. When you have finished moving the chamber, lock the wheels to prevent unintentional movement. See [Figure 5-1](#).

5.2 Packing

Use the original packaging material. If you do not have the original packaging, use similar materials that provide the same level of protection. Use sufficient padding to prevent unintentional mechanical effects during transportation.

Leave the door locked when transporting the chamber.

To pack the chamber for transport

Use the original packaging material. The figures shown in the following step-by-step instructions are intended as examples to illustrate correct packing.



1. Wrap up the chamber in the antistatic wrap for electrostatic protection.
2. The front panel of the transport crate has wooden wedges; place the front panel on the floor and use it as a ramp.



3. Unlock the wheels of the chamber. See [Figure 5-1](#).
4. Carefully push the chamber up the ramp and into the transport crate, rear panel first. See "[Correct moving](#)" on page 28.
5. Lock the front wheels. See [Figure 5-1](#).
6. Attach the timber beams as shown in the figure. Their purpose is to restrict the movement of the chamber during transport.

- a) Position the timber beam as close to the chamber as possible.
- b) Screw on the timber beam securely from the outside.
- c) Repeat both steps for the second timber beam.



7. Store the small parts and any accessories in their boxes.
8. Place the boxes on the crate floor in front of the chamber.
9. Prevent the boxes from moving on the crate floor by attaching a third timber beam directly above them.



10. Close the front crate panel.

11. Secure the front crate panel:
 - Close all fastenings on the crate.
 - If there are no fastenings, screw on the front crate panel securely.
12. Secure the crate with two straps.

5.3 Transport

The following activities are restricted to the [transportation appointee](#).

When moving the chamber using transporting equipment, make sure that the chamber is properly secured. Do not secure the chamber at any mounted accessories.

You can use the rear handles for this purpose. See [Figure 4-3](#).

When moving the product in a vehicle:

1. Pack the chamber in its transport crate as described in "[To pack the chamber for transport](#)" on page 29.
2. If the truck has a tailgate lift for loading and unloading, make sure that it can support the weight of the chamber before lifting it.
3. Secure the transport crate to prevent it from moving. Make sure that the straps you use can withstand the weight of the chamber, especially under increased forces due to sudden acceleration or emergency braking.
4. After transportation:
 - a) Unpack the chamber.
 - b) Check the tilt watch. See [Chapter 6.2, "Unpacking and Checking"](#), on page 35.

Transport altitude

Unless otherwise specified in the data sheet, the maximum transport altitude without pressure compensation is 4500 m above sea level.

5.4 Storage

Protect the product against dust. Ensure that the environmental conditions, e.g. temperature range and climatic load, meet the values specified in the data sheet.

If you leave the chamber unused for some time (e.g. between production periods), consider the following:

- ▶ **NOTICE!** Gasket can suffer from wear. Keeping the door's RF gasket under the closed door's mechanical pressure for a long time can reduce the gasket's elasticity.

To improve the chamber's long-term radiation shielding efficiency, we recommend relaxing the gasket by leaving the door open.

The attainable radiation shielding efficiency of the door's RF gasket depends on how long the gasket remains in a relaxed state. Extended periods of gasket relaxation preserve its long-term shielding efficiency.

6 Installation and Commissioning

The following activities are restricted to [maintenance personnel](#).

Familiarize yourself with residual risks and potentially dangerous situations.

See [Chapter 2.2, "Residual Risks"](#), on page 11 and [Chapter 2.3, "Potentially Dangerous Situations"](#), on page 13.

Execute these activities in the same order as given in this handbook:

• Choosing the Operating Site	34
• Unpacking and Checking	35
• Installing the Chamber	37
• Connecting to Power	38
• Connecting to Control	39
• Connecting Test Equipment	40
• Testing Safety Systems	40

6.1 Choosing the Operating Site

Only use the chamber indoors. The chamber casing is not waterproof.

Select an operating site that provides safe conditions for installing and operating the chamber.

Ensure the following:

- Only trained personnel can access the operating site.
- The room has a level floor surface and sufficient bearing capacity.
- The operating site leaves sufficient room to open the door without obstruction and to access:
 - Chamber, especially the area behind the open door
 - Connectors on all sides
 - Brakes of the wheels
 - Panic button or power plug, see ["Power connection requirements"](#) on page 38 and [Chapter 3.1, "Emergency Stop"](#), on page 17
- The environmental conditions such as ambient temperature and humidity match the values in the data sheet.
- The operating site is at an altitude of maximum 2000 m above sea level.
- The environment has pollution degree 2, where only nonconductive contamination occurs. Occasionally, temporary conductivity caused by condensation is to be expected.
- The electromagnetic compatibility (EMC) class of the chamber is class B.

Electromagnetic compatibility classes

The [EMC](#) class indicates where you can operate the chamber.

- Class B equipment is suitable for use in:
 - Residential environments
 - Environments that are directly connected to a low-voltage supply network that supplies residential buildings
- Class A equipment is intended for use in industrial environments. It can cause radio disturbances in residential environments due to possible conducted and radiated disturbances. It is therefore not suitable for class B environments. If class A equipment causes radio disturbances, take appropriate measures to eliminate them.

6.2 Unpacking and Checking

Familiarize yourself with residual risks and potentially dangerous situations.

See [Chapter 2.2, "Residual Risks"](#), on page 11 and [Chapter 2.3, "Potentially Dangerous Situations"](#), on page 13.

The chamber is delivered in a wooden transport crate; see [Chapter 5.2, "Packing"](#), on page 29.

To unpack and check the chamber

1. Ensure that the transport crate is standing on a strong, flat and level surface.
2. Ensure that there is sufficient room in front of the crate.

You can fold down the front panel of the crate. The front panel has two long wooden wedges which extend from the top of the panel down to the crate base, to which the panel is attached by 3 hinges. On some crate versions, the front panel has 6 metal fastenings for securing it to the rest of the crate.

In a rectangular area with the following dimensions, there must be no obstacles, and the floor surface must be strong, flat and level:

 - Width: at least the same as the crate, 1.08 m
 - Length: extending to at least **3.5 m** from the crate
3. Check the transport crate for visible damage.
4. If you find any damage, immediately contact the carrier who delivered the chamber. Do not refuse the delivery, but make a note on the delivery receipt. Take photos of the damage as proof.

Note: Damage to the transport crate does not necessarily mean that the product inside the crate is also damaged. If, however, the product is damaged, the delivery receipt and your photos can help clarify who is responsible for the damage.
5. Check whether the transport crate has suffered shock or impact during transportation.

The transport crate has 2 shock indicators, as shown in [Figure 6-1](#). If during transportation the crate suffered mechanical impact that exceeds a defined limit, the shock indicators turn **red**.



Figure 6-1: Shock indicator, OK if colorless, broken if red

6. Check whether the transport crate was tilted during transportation.

The transport crate has 2 tilt indicators, as shown in [Figure 6-2](#). One is attached to one of the side panels and one to the rear panel. If during transportation the crate was tilted more than 30°, one of more glass balls in the tilt indicator are displaced.



Figure 6-2: Tilt indicator, OK if balls are in original positions

7. If the indicators indicate shock or tilting > 30°, immediately contact the carrier who delivered the chamber.
 - a) Do not refuse the delivery, but make notation on the delivery receipt.
 - b) Take photos of the shock and tilt indicators as proof.

Note: If the transport crate is subjected to shock or tilting during transportation, this fact does not necessarily mean that the product inside the crate is damaged. If, however, the product is damaged, the delivery receipt and your photos can help clarify who is responsible for the damage.

8. Open the front panel of the transport crate.
To do so:
 - a) Cut the plastic straps around the crate.
 - b) Depending on the crate version, either unscrew the front panel or undo the 6 metal latches.
9. Carefully lower the front panel of the crate.

The wooden wedges of the front panel rest on the floor so that the front panel forms a ramp for the chamber.

10. On the outside of the crate, unscrew the timber beams that prevent the chamber from moving out of the crate.
11. Remove the timber beams.
12. If accessories are included with the chamber, take the accessories out of the crate.
13. Release the brakes of the front wheels. See [Figure 5-1](#).
14. **WARNING!** The chamber is heavy. Wear protective clothing, especially safety footwear with protective toe caps.
Move the chamber out of the crate and down the ramp. See [Chapter 5.1, "Moving the Chamber"](#), on page 28.
When moving the chamber, hold it at any solid parts of its walls.
15. Engage the wheel brakes.
16. Remove the antistatic wrap from the chamber.
17. Keep the original packing material. Use it if you need to transport the chamber later.
We recommend storing the transport crate in its original upright position so that the tilt indicators can be used again for future transportation.
18. Check the delivery against the delivery notes or accessory list to ensure that all items are present.
19. Check the chamber for damage.
If the delivery is incomplete or equipment is damaged, contact Rohde & Schwarz.

6.3 Installing the Chamber

Familiarize yourself with residual risks and potentially dangerous situations.

See [Chapter 2.2, "Residual Risks"](#), on page 11 and [Chapter 2.3, "Potentially Dangerous Situations"](#), on page 13.

To install the chamber:

1. Move the chamber to its operating site.
See [Chapter 6.1, "Choosing the Operating Site"](#), on page 34.
See [Chapter 5.1, "Moving the Chamber"](#), on page 28.
2. Position it for optimum accessibility, for example next to a rack holding your other test equipment.
3. Engage the brakes on the chamber's wheels.

6.4 Connecting to Power

The chamber's AC power input socket [A221] is on the rear feedthrough panel.

See [Figure 4-5](#).

A power cable matching the mains power socket type used in your region is included with the chamber.

Power connection requirements

Familiarize yourself with residual risks and potentially dangerous situations.

See [Chapter 2.2, "Residual Risks"](#), on page 11 and [Chapter 2.3, "Potentially Dangerous Situations"](#), on page 13.



We recommend installing a **panic button**. It is a power-off switch that ensures quick deactivation of the chamber if an **emergency** occurs. The panic button disconnects the mains power socket from the power source. Use exactly this mains power socket to plug in the power cord that is connected to the power supply unit [A221].

A panic button is not included with the chamber. The picture shows an example.

Make sure that:

- The panic button is installed in a place that the operator can reach easily.
- Every operator knows where the panic button is located.
- The mains power socket is disconnected from mains grid power when you hit the panic button
- In the next procedure, make sure to connect the power cable to the correct mains power socket, so that hitting the panic button interrupts AC power to the chamber.

To prepare the power connection

1. Connect the C19 plug of the included power cable to the socket of the power supply unit [A221] at the rear of the chamber.
2. Make sure to comply with the ["Power connection requirements"](#) on page 38.

To activate the chamber

The chamber is activated when it is connected to the power source. It does not have a separate [ON / OFF] switch.

- ▶ Connect the power cable to the mains power socket that is disconnected from power when hitting the panic button.

The chamber is activated.

6.5 Connecting to Control

The fiber-optic interface allows remote control of the positioners from the R&S TC-CCPCTRL1, maturo GmbH NCD controller, included in the delivery. The chamber's fiber-optic interface is on its lower rear feedthrough panel [A222]; see [Figure 4-5](#).

Connection requirements:

- The chamber is connected to power.
- The NCD controller is connected to power.
- The NCD controller is switched off.

To connect the NCD controller

Make the following fiber-optic connections between the FO feedthrough [A222] and the FO control ports on the rear of the NCD controller:

1. Connect the FO cable with the **green** connector to the **top left** port of feedthrough [A222].
2. Connect the green connector on the other end of the same FO cable to the green connector of [Port 1] of the NCD controller.
3. Connect the FO cable with the **blue** connector to the **top right** port of feedthrough [A222].
4. Connect the blue connector on the other end of the same FO cable to the blue connector of [Port 1] of the NCD controller.

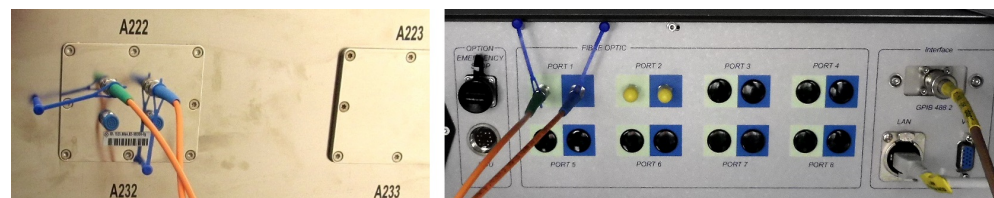

Figure 6-3: Fiber-optic (FO) control connections

Left = FO feedthrough [A222]

Right = FO control ports on the rear panel of the NCD controller

The color-coded (green and blue) FO control connections in [Figure 6-3](#) are for the transmit (TX) and receive (RX) direction, respectively.

5. Switch on the power switch on the rear panel of the NCD controller.

The NCD controller checks that its fiber-optic connections are communicating correctly with the positioning hardware in the chamber.

Note: Bad FO connection. If the control connection is bad (crossed blue and green colors) or missing (cable defective or not fully plugged in), "**M-WPTC**" in the controller's display is highlighted red.

The NCD controller sends optical commands via the TX connections to the control unit in the chamber's lower compartment. This unit converts the optical commands to electrical signals and forwards them to the azimuth turntable and to the elevation positioner. The return path for control communication uses the RX connections. The user manual for the NCD controller is available online at www.maturo-gmbh.com/en/products/controller.

6.6 Connecting Test Equipment

Only an **expert user** can perform this task as described in the [Configuration Manual](#).

6.7 Testing Safety Systems

When the door is open, the chamber's lower interlock system ([Figure 4-7](#)) must prevent any positioner movement. You can check whether the interlock is functioning properly by opening the door; the positioner has to stop moving.

To test the interlock

1. Make sure that the chamber is connected to power; see [Chapter 6.4, "Connecting to Power"](#), on page 38.
2. Make sure that the chamber is connected to control; see [Chapter 6.5, "Connecting to Control"](#), on page 39.
3. Open the door; see [Chapter 7.3.3, "Opening the Door"](#), on page 45.
4. Take note of the positioner's position.
5. Close the door; see [Chapter 7.3.4, "Closing the Door"](#), on page 45.
6. Send a command from the controller to start movement of the positioner.
7. Open the door.
8. Check the positioner as follows:
 - **Test passed**
If the positioner has moved, but is now no longer moving, the interlock successfully stopped movement when the door was opened.
 - **Test result is unclear**
If the positioner has not moved from its original position noted in [step 4](#), it is not possible to state unequivocally that the interlock is functioning properly.
 - **Test failed**
If the positioner continues to move when the door is open, the interlock has failed.

Do not touch the positioner. Close the door.

9. **WARNING!** Risk of personal injury. See "[Positioner moves with high torque](#)" on page 12.

If the interlock has failed the test or the test result is unclear, do not use the chamber until an [expert user](#) repeats the test.

10. If the interlock fails the test again, take the following steps:

- a) Stop work at the chamber immediately.
- b) Take the chamber out of commission to make sure that nobody else can use it. See [Chapter 10.1, "Taking Out of Commission"](#), on page 74.
- c) Contact Rohde & Schwarz customer support. See [Chapter 9.3, "Contacting Customer Support"](#), on page 73.

7 Operation

Familiarize yourself with residual risks and potentially dangerous situations.

See [Chapter 2.2, "Residual Risks"](#), on page 11 and [Chapter 2.3, "Potentially Dangerous Situations"](#), on page 13.

The setups given in this handbook, such as specific cable connections and antenna positions, provide just a few examples of the many possible uses. Rohde & Schwarz does not recommend a particular setup.

Operating the chamber involves the activities described in the following subchapters:

• Activating the Chamber	42
• Deactivating the Chamber	42
• Operating the Door	43
• Placing a DUT in the Chamber	45
• Connecting a DUT	54
• Operating the Positioning System	55
• Preparing for Shift End	63

7.1 Activating the Chamber

As a prerequisite, ensure that all instructions described in [Chapter 6, "Installation and Commissioning"](#), on page 34 are executed.

To activate the chamber

1. Connect the power cable to a mains power socket.
2. After activation, note that operating the door requires an initial referencing procedure.
See [Chapter 7.3.2, "Referencing the Door's Lock"](#), on page 44.
3. We recommend leaving the chamber connected to power always.
Permanent connection to power helps prolong the life of the integrated lithium storage battery; see [Chapter 9.2.1, "Positioner Loses Absolute Position"](#), on page 72.

7.2 Deactivating the Chamber

Disconnecting the chamber from power deactivates it. It does not have a separate [ON / OFF] switch.

To deactivate the chamber

1. Disconnect the chamber from its electric power supply.

2. If you intend to deactivate the chamber for a long period of time, we recommend relaxing the door's gasket by manually opening the chamber door (as far as you wish); see [Chapter 5.4, "Storage"](#), on page 32.

Emergency deactivation

See [Chapter 3, "Emergencies"](#), on page 17.

7.3 Operating the Door

Familiarize yourself with residual risks and potentially dangerous situations.

See ["Door of the chamber is heavy"](#) on page 12 and ["Risk of crushing fingers when moving the door"](#) on page 12.

This chapter describes operating the chamber door.

Door operation involves the following activities:

- Checking the door's status
 - Running an initial auto-referencing procedure of the door's locking mechanism
 - Unlocking the door by pushing a button
 - Opening the door manually
 - Closing the door manually
 - Locking the door by pushing a button
- | | |
|---|----|
| • Door Status | 43 |
| • Referencing the Door's Lock | 44 |
| • Opening the Door | 45 |
| • Closing the Door | 45 |

7.3.1 Door Status



Figure 7-1: Light in the door's [LOCK / UNLOCK] button

Left = Locking system inactive, door unlocked

Right = Locking system engaged, door locked

The light in the door button indicates the door and chamber status as follows:

Light	Door and chamber status
Green	The door is closed and locked and the chamber is ready for measurements.
No light	The door is unlocked or the chamber is disconnected from power.

You cannot query the door's status remotely.

7.3.2 Referencing the Door's Lock

When the door is locked or unlocked for the first time after the chamber is connected to power, the door's locking mechanism must perform an initial referencing procedure.

To reference the lock, if the door is open

If the door is **unlocked and open** during power-off, the door-locking latches (labeled (7) in [Figure 4-2](#)) are in their upper default position, which requires the following referencing procedure:

1. Close the door manually.
2. Gently **hold the door closed** during the referencing procedure.
If, for example, the chamber is not standing on a perfectly level surface, the door can open slightly. This movement can interrupt the interlock, which prevents completion of the referencing procedure.
3. Push the [LOCK / UNLOCK] button.
The latches move upward a few millimeters, to locate their referenced top position. After locating this position, the latches move down to lock the door.
4. **Wait** to finish before operating the door-locking mechanism again.
Referencing is finished when you can no longer hear the door mechanism moving.

To reference the lock, if the door is closed

If the door is **closed and locked** during power-off, the door-locking latches are in a lower position, which requires the following referencing procedure:

1. Push the [LOCK / UNLOCK] button.
The latches slowly move upward to their top position. During this movement, the mechanism unlocks the door. After locating their referenced top position, the latches move down a few millimeters to their default open position, without locking the door.
2. **Wait** to finish before operating the door-locking mechanism again.
Referencing is finished when you can no longer hear the door mechanism moving.

7.3.3 Opening the Door

Familiarize yourself with residual risks and potentially dangerous situations.

See ["Operating the door"](#) on page 14.

Prerequisites:

- You have performed the referencing procedure; see [Chapter 7.3.2, "Referencing the Door's Lock"](#), on page 44.
- The door is closed and locked.
- The green light in the [LOCK / UNLOCK] button is on.

To open the door

1. Push the [LOCK / UNLOCK] button.
The light in the button switches off and the door is unlocked.
2. Manually pull the door open by its handle.
This step completes the opening procedure.

7.3.4 Closing the Door

Familiarize yourself with residual risks and potentially dangerous situations.

See ["Operating the door"](#) on page 14.

Prerequisites:

- You have performed the referencing procedure, see [Chapter 7.3.2, "Referencing the Door's Lock"](#), on page 44.
- The door is open.
- The light in the [LOCK / UNLOCK] button is off.

To close the door

1. Manually push the door closed by its handle.
2. Push the [LOCK / UNLOCK] button.
The door starts locking.
3. Wait until the door is locked.
The light in the button turns green.
This step completes the closing procedure.

7.4 Placing a DUT in the Chamber

Familiarize yourself with residual risks and potentially dangerous situations.

See ["Operating the door"](#) on page 14, ["Positioner moves with high torque"](#) on page 12 and ["Class 2 lasers inside the chamber"](#) on page 12.

You can place your DUT on the height-adjustable azimuth turntable, labeled 2 in [Figure 4-10](#), or on a DUT holder mounted on the turntable.

Only an [expert user](#) is allowed to mount and configure DUT holders. An [operator](#) can use the DUT holders as configured.

To place a DUT in the chamber

1. Define the positioners' azimuth and elevation angles that you want to use as default or starting positions for measurements.
Typically, select the 0° positions.
2. Move the positioners to the selected azimuth and elevation angles.
See [Chapter 7.6, "Operating the Positioning System"](#), on page 55
3. Stop any positioner movement.
4. Open the door; see [Chapter 7.3.3, "Opening the Door"](#), on page 45.
5. Place the DUT on the azimuth turntable or on a DUT holder mounted on the turntable.
For DUT mass and eccentricity limits, see [Table 7-1](#).
6. If cables are available for connecting the DUT, connect it.
See [Chapter 7.5, "Connecting a DUT"](#), on page 54.
7. Push the [Laser] button ([Figure 4-9](#)).
This button switches on the alignment lasers.
8. If the DUT is not positioned at the correct height, move the turntable to a higher or lower position; see ["To move the DUT to a higher or lower position"](#) on page 46.
9. To align the DUT on the DUT holder in lateral direction, move it to the center of the vertical laser crosshair.
10. Optionally rotate the DUT to the desired orientation.
11. Fix the DUT using the available screws or clamping claws.
Clamping depends on the DUT holder types, described in the following subchapters.
12. To switch off the alignment lasers, push the [Laser] button.
13. Close the door; see [Chapter 7.3.4, "Closing the Door"](#), on page 45.

To move the DUT to a higher or lower position

Use the crank-driven lifting mechanism of the turntable's telescopic tube.

1. Consider the weight of your DUT because the crank drive has a limited load capacity:
 - For lifting, maximum 2 kg

- For lowering, maximum 3 kg
2. If the DUT is heavier, remove it.
 3. **NOTICE!** Risk of damaging the crank drive's mechanism. Damage occurs if you move the crank drive without **releasing** the clamping screw (1).

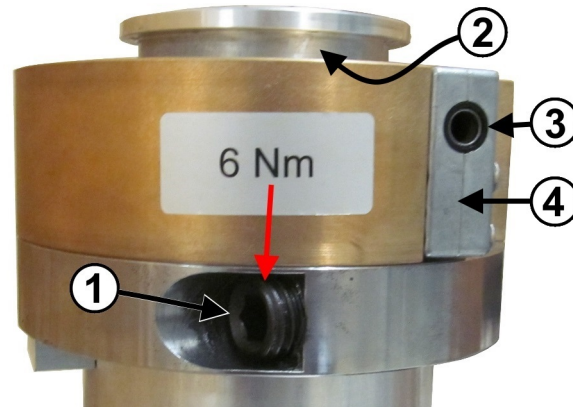

Figure 7-2: Turntable with clamping screw and crank drive

- 1 = Clamping screw for the telescopic tube
- 2 = Telescopic tube of the turntable's lifting mechanism
- 3 = Hexagonal socket for insertion of the crank
- 4 = Crank drive for lifting and lowering the telescopic tube

4. Insert the crank (labeled 4 in [Figure 7-3](#)) into the hexagonal socket (labeled 3 in [Figure 7-2](#)).

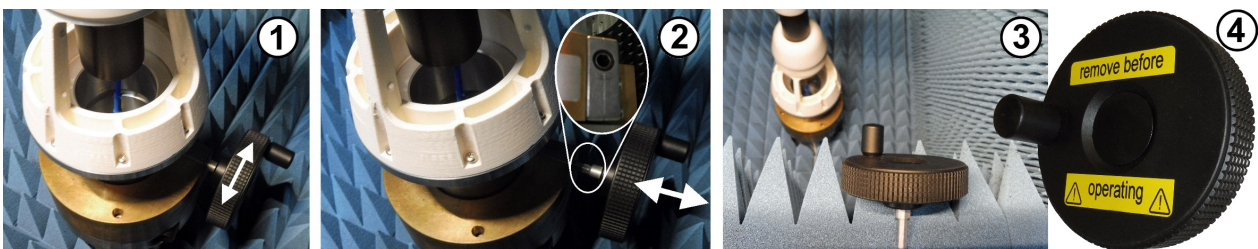

Figure 7-3: Turntable's crank

- 1 = Rotating the crank (white arrow) lifts or lowers the turntable
- 2 = Crank is inserted into the hexagonal socket (white arrow)
- 3 = Crank removed from the turntable
- 4 = [remove before operating]: Remove the crank from the turntable before operating the positioners

5. Rotate the crank ([Figure 7-3](#)) until the DUT's height is adjusted correctly to the horizontal laser crosshair.
6. **NOTICE!** Risk of destroying the antenna. If you forget to remove the crank, the antenna can collide with the crank when the positioner moves.
Remove the crank by pulling it off in the direction of its axis.
7. Tighten the clamping screw to a torque of maximum 6 Nm.
8. If you have removed the DUT from the turntable, put it back.

9. Proceed with [step 9](#) under "[To place a DUT in the chamber](#)" on page 46.

- [DUT Mass and Eccentricity](#).....48
- [Metal DUT Holder Set](#).....48
- [Telescopic Tube DUT Holder](#).....50
- [Rohacell DUT Holder](#).....50
- [PCB Holder Set](#).....51

7.4.1 DUT Mass and Eccentricity

Place the DUT's center of gravity close to the center of the DUT holder.

The maximum permissible mass of your DUT depends on the DUT holder used and on the DUT's centricity. If you place the DUT's center of gravity with a lateral offset relative to the turntable's axis of rotation, the maximum permissible mass decreases. [Table 7-1](#) shows the permissible mass at a given maximum offset.

Table 7-1: Limits of DUT mass

Holder used for DUT	Maximum mass, depending on offset from azimuth axis
No holder, DUT directly on turntable	20 kg with 0 mm offset 10 kg with 25 mm offset
DUT on metal holders (combined, 385 mm)	10 kg with up to 10 mm offset
DUT on telescopic polymer holder (extended)	1 kg with 0 mm offset 0.3 kg with 25 mm offset
DUT on Rohacell holder	3 kg with 0 mm offset 2 kg with 30 mm offset

If your DUT has a mass distribution that is off-center, consider combining this DUT with a suitable counterpoise. This combination can improve the concentricity of your DUT's mass with the turntable.

7.4.2 Metal DUT Holder Set

Only an [expert user](#) is allowed to mount and configure DUT holders. An [operator](#) can use the DUT holders as configured.

A set of 3 aluminum DUT holder tubes, labeled 1 to 3 in [Figure 7-4](#), is included in the delivery. The tubes have the following heights:

- Short DUT holder tube (1) = 40 mm
- Medium DUT holder tube (2) = 115 mm
- Long DUT holder tube (3) = 230 mm

The tubes are designed as a heavy-duty DUT support to stand on the azimuth turntable. Each tube has a large hole in its wall for feeding cables through to the DUT.

The upper end of each tube is flat, whereas the lower end has a protruding (cantilevered) rim. This rim locks with the basic azimuth turntable or with the upper flat end of another tube. This shape allows you to stack the tubes so that DUTs of various sizes can be positioned at the antenna focus.

A DUT fixing plate (6) is designed to cover the top of the (stacked) tubes. The plate has a diameter of 90 mm and adds another 10 mm to the height of the tubes.

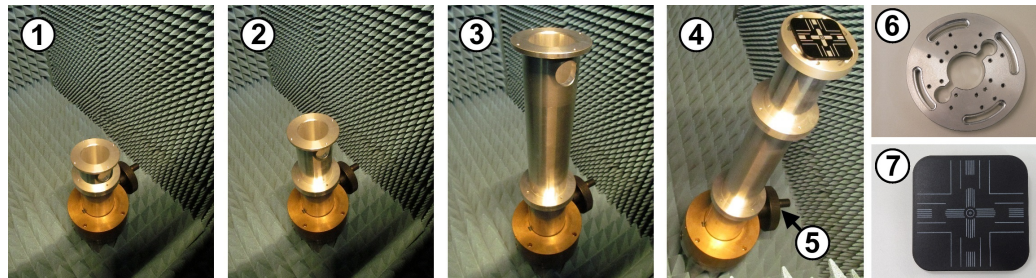

Figure 7-4: Different metal DUT holders on the turntable platform

- 1 = Short DUT holder tube
- 2 = Medium DUT holder tube
- 3 = Long DUT holder tube
- 4 = Combined long and medium DUT holder tube (here with fixing plate and laser positioning target on top)
- 5 = Crank drive for lifting or lowering the turntable (remove crank before operating the arm; see [Figure 7-3](#))
- 6 = DUT fixing plate
- 7 = Laser positioning target

Prerequisites for fixing your DUT to the DUT holder tubes:

- An **expert user** has stacked the tubes to a height at which your DUT is approximately level with the rotational axis of the antenna positioner arm
- An **expert user** has placed the DUT fixing plate on the top DUT holder tube and screwed all elements together.
- An **expert user** has screwed the DUT holder assembly to the turntable.
- An **expert user** has threaded all cables required for connecting the DUT through the holder and close to the DUT's position.

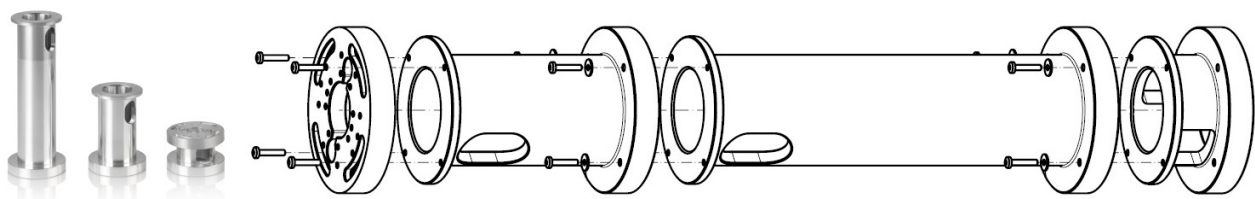

Figure 7-5: Example showing an assembly comprising all the metal DUT holder tubes

- Left = Photo of the three metal tubes (the shortest one with fixing plate)
- Right = Drawing showing how the tubes and fixing plate are joined

To place the DUT on the holder

- ▶ See "[To place a DUT in the chamber](#)" on page 46.

7.4.3 Telescopic Tube DUT Holder

Only an **expert user** is allowed to mount and configure DUT holders. An **operator** can use the DUT holders as configured.

The R&S ATS AZTAB1 telescopic tube DUT holder (order no. 1532.7624.02) consists of a hollow base (white) with clamping collar and an extendable tube (black) with 3 adapters. An **expert user** can set it to heights between 285 mm and 380 mm and combine it with various DUT adapters. Both the black and white parts of the holder are made of the RF-opaque thermoplastic polymer polyoxymethylene (POM). It has a solid metal base and is designed to stand on the azimuth turntable, allowing cables to be fed through to the DUT.



Figure 7-6: Examples of telescopic DUT holder configurations with various adapters

- 1 = Telescopic tube holder with flat perforated DUT adapter plate
- 2 = Same holder, but extended to full height and maintenance cover opened
- 3 = Same holder with pointed adapter cone
- 4 = Top view of the holder with perforated flat DUT adapter plate
- 5 = View of the metal base plate (aluminum) for mounting the holder onto the turntable

Prerequisites for fixing your DUT to the telescopic tube DUT holder:

- An **expert user** has assembled the holder for approximately the correct height that brings your DUT up to the rotational axis of the antenna positioner arm.
- An **expert user** has fixed the holder on the turntable.
- An **expert user** has threaded all cables required for connecting the DUT through the holder and close to the DUT's position.

To place the DUT on the holder

- ▶ See "[To place a DUT in the chamber](#)" on page 46.

7.4.4 Rohacell DUT Holder

Only an **expert user** is allowed to mount and configure DUT holders. An **operator** can use the DUT holders as configured.

The R&S ATS AZTAB2 Rohacell DUT holder (order no. 1532.8189.02) is originally mounted in the R&S ATS1000 on delivery. It is a solid square tower, made of RF-opaque polymer foam (polymethacrylimide, PMI, Rohacell), which is available in 2 heights:

365 mm and 245 mm, including the circular ABS polymer base with diameter 128 mm. The metal base plate (labeled 5 in [Figure 7-6](#)) on which the tower stands adds an additional 10 mm to the tower's overall height. The rectangular table top has 2 adjustable clamps to fix a DUT.

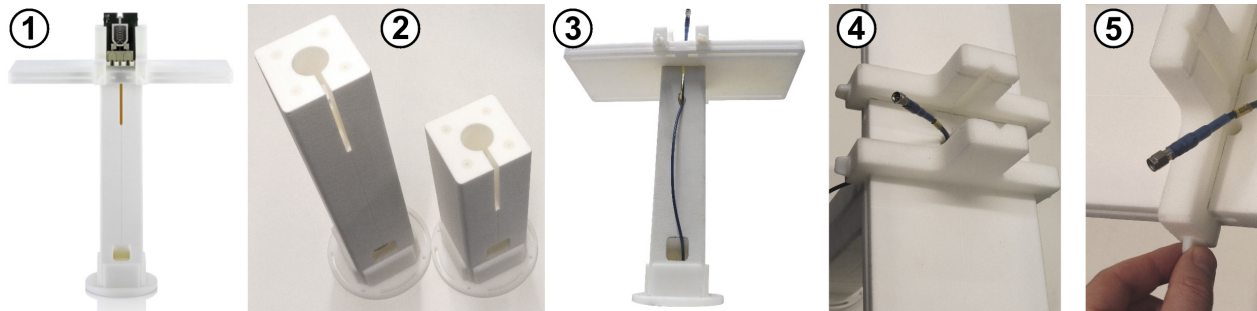

Figure 7-7: Rohacell DUT holder with table top and adjustable clamping fixtures

- 1 = Rohacell holder with DUT (example) mounted on the table top
- 2 = Square towers, height 365 mm and 245 mm, with 4 screw holes for fixing the table top
- 3 = Since the solid tower has no through bore, cables are fed through the lower and upper holes
- 4 = 2 adjustable DUT holder fixtures on the table top
- 5 = Tightening the polymer screws that lock the adjustable fixtures

Prerequisites for fixing your DUT to the Rohacell DUT holder:

- An **expert user** has assembled the holder to a height at which your DUT is approximately level with the rotational axis of the antenna positioner arm.
- An **expert user** has screwed the holder to the turntable.
- An **expert user** has threaded all cables required for connecting the DUT through the holder and close to the DUT's position.

To place the DUT on the holder

- ▶ See "[To place a DUT in the chamber](#)" on page 46.

To clamp the DUT on the holder

1. Loosen the 4 polymer screws of the adjustable fixtures (labeled 4 in [Figure 7-7](#)).
2. Move the fixtures so that they are wider apart than the width of the DUT.
3. Carefully position the fixtures such that the DUT is clamped at the center of the holder.
4. Lock the fixtures in position by tightening the screws finger-tight (5).

7.4.5 PCB Holder Set

Only an **expert user** is allowed to mount and configure DUT holders. An **operator** can use the DUT holders as configured.

The PCB holder set (order no. 1534.9601.00) is delivered with the R&S ATS-AZTAB2. It can be used also with the R&S ATS-AZTAB1.

This holder can carry a printed circuit board (PCB) in addition to your DUT, for example if your setup requires a separate PCB inside the chamber for signal conditioning. Place your DUT on top of the DUT holder, and place your signal conditioning PCB on the PCB holder set.

Prerequisites for using the PCB holder set:

- An **expert user** has assembled the PCB holder.
- An **expert user** has fixed the PCB on the PCB holder by clamping claws and screws (labeled 5 to 7 in [Figure 7-8](#)).
- An **expert user** has fixed the DUT holder's metal base plate (8) on the turntable (9).
- An **expert user** has fixed the PCB holder below the base plate, considering the position of the turntable's crank ([Figure 7-3](#)).
- An **expert user** has threaded all cables required for connecting the DUT from the PCB holder close to the DUT's position.

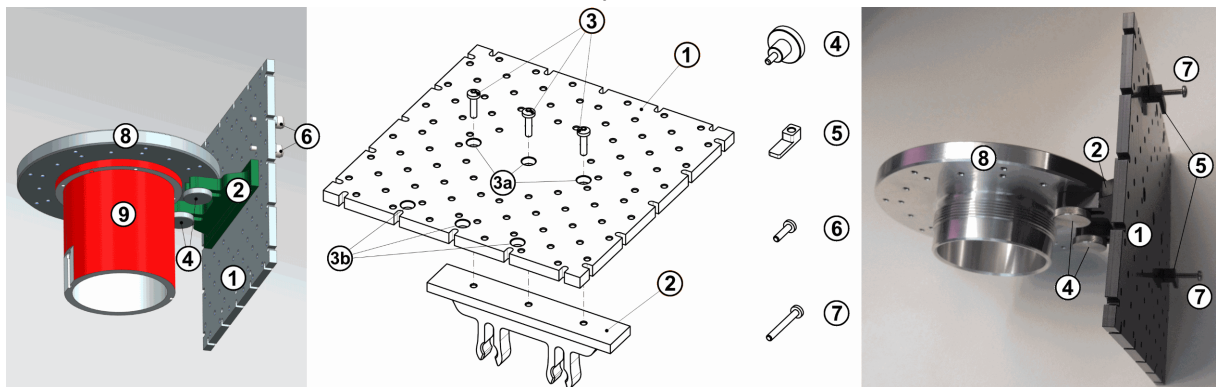

Figure 7-8: Holder set for carrying a printed circuit board (PCB) in addition to a DUT

- 1 = Mounting plate
- 2 = Mounting bracket
- 3 = Assembly screws (M3 x 12 mm)
- 3a = Centered assembly holes
- 3b = Lateral assembly holes
- 4 = 2 mounting screws (M3 x 7 mm)
- 5 = Clamping claws
- 6 = Short clamping screws (M3 x 12 mm)
- 7 = Long clamping screws (M3 x 25 mm)
- 8 = Metal base plate of a polymer DUT holder set (labeled 5 in [Figure 7-6](#))
- 9 = Telescopic tube of the turntable's lifting mechanism (labeled 2 in [Figure 7-2](#))

NOTICE**Risk of damaging the antenna**

If the **expert user** mounts a large device on the PCB holder set, it can collide with the measurement antenna in the following situations:

- The elevation arm moves to low elevations, while the PCB holder set is at a turntable position toward the rear of the chamber.
- The turntable rotates while the elevation arm is at a low elevation.

Such a collision can damage or destroy the antenna.

If any of the parameters listed below indicate a risk of collision in your setup, or if in doubt, the **expert user** must perform careful trial runs at the lowest permissible elevation position.

To avoid the risk of antenna damage, limit its elevation to the permissible angles.

The risk of a collision depends on the following parameters:

- The height position of the azimuth turntable (highest risk at low positions)
- The elevation angle at the antenna arm (highest risk in the +165° position)
- The size of the PCB (highest risk with large or thick PCB)
- The position of the PCB (highest risk with PCB protruding sideways beyond the mounting plate)
- The mounting position of the PCB holder set (highest risk at low positions)
- The azimuth position, as shown in [Figure 7-9](#)

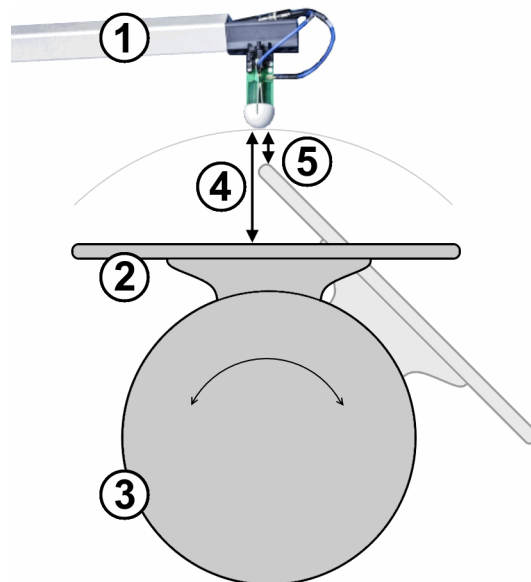

Figure 7-9: Top view of the turntable with mounted PCB holder set and antenna arm nearby

- 1 = Elevation arm with antenna, here moved to the lowest position at elevation = +165°
- 2 = PCB holder set
- 3 = Turntable
- 4 = Distance approx. 30 mm from antenna to mounting plate (consider this azimuth as 0°)
- 5 = Distance approx. 10 mm from antenna to mounting plate, when azimuth is 45°

NOTICE

Risk of damaging absorbers

An **expert user** can assemble the PCB holder set using the centered (3a) or lateral (3b) assembly holes, as labeled in [Figure 7-8](#).

If the lateral assembly holes (3b) are used **and** the holder set is attached with its mounting plate pointing downward, it can collide with absorbers on the chamber's floor. Such a collision can damage or destroy the absorbers, especially if the turntable rotates at a low position.

To avoid this risk, the **expert user** must select one of the following options for the mounting plate:

- Attaching the plate at a centered position, using the centered assembly holes (3a)
- Attaching the plate pointing upward, using the lateral assembly holes (3b)
- Leaving the turntable at a higher position, at least 1 cm above its lowest position

If you observe at least one of these points in your setup, the mounting plate of the attached PCB holder set cannot collide with the absorbers.

7.5 Connecting a DUT

Familiarize yourself with residual risks and potentially dangerous situations.

See "[Door of the chamber is heavy](#)" on page 12 and "[Operating the door](#)" on page 14.

Various feedthroughs with interior and exterior connectors allow cable connections to the DUT while it is tested in the chamber.

- Every **user** can connect a DUT to **cables** available at the **interior** feedthrough connectors inside the chamber.
Prerequisite: an **expert user** has provided the required cables close to the DUT's position.
- Only an **expert user** is allowed to connect, disconnect or exchange cables at exterior and interior feedthrough connectors
- Only Rohde & Schwarz **service personnel** are allowed to mount, remove or exchange feedthroughs

We recommend connecting your DUT to cables available in the chamber before you fix the DUT on top of a holder. See [Chapter 7.4, "Placing a DUT in the Chamber"](#), on page 45.

The following DUT connection options are available inside the chamber:

- LAN connection to the Gigabit Ethernet feedthrough [A121]

- Serial connection to the USB 2.0 feedthrough [A122]
Note that the exterior connector is USB 2.0 despite the connector in the chamber being USB 3.1.
- Parallel connection to the 9-pin D-Sub feedthrough [A123] (pins 1 to 8)
- RF connection via a rotary joint to feedthrough [A124] (left connector)

For details on the feedthroughs, see [Table 4-1](#).

To connect a DUT

1. If one or more control or supply cables are available for connecting the DUT, connect them.
2. If an RF cable is available for connecting the DUT to your test equipment, connect it.

Risk of RF connector and cable damage / torque recommendations

Excessive tightening of coaxial RF connectors can damage the cables and connectors. Too weak tightening causes inaccurate measurement results.

Always use a torque wrench suitable for the connector type and apply the torque specified in **application note 1MA99**, which is available on the internet at www.rohde-schwarz.com. It provides additional information on the care and handling of RF connectors.

For RF connectors, we recommend applying the following torque limits:

- **90 N-cm** for **PC** connectors (3.5 mm / 2.92 mm / 2.4 mm / 1.85 mm)

Never use a standard open-end wrench. We offer torque wrenches for various connectors. For ordering information, see application note 1MA99.

7.6 Operating the Positioning System

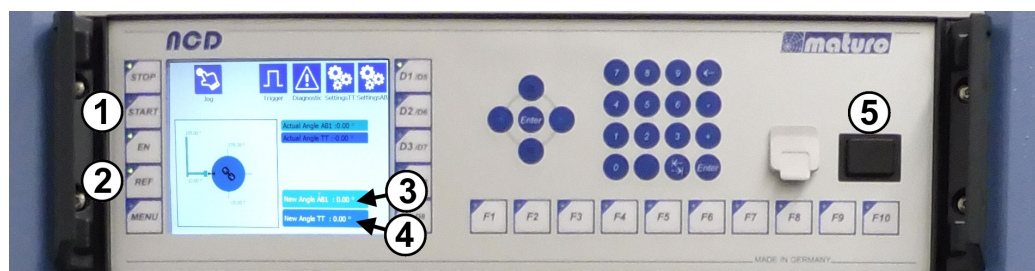

Figure 7-10: NCD controller for elevation positioner and azimuth turntable

- 1 = [START] button for starting positioner movement
- 2 = [REF] button for referencing the turntable
- 3 = Control element "New Angle AB1" (antenna boom, elevation positioner arm)
- 4 = Control element "New Angle TT" (turntable)
- 5 = Standby button

Before operating the positioning system, you must **activate** the controller and **reference** the azimuth turntable.

The turntable requires referencing because one of its turning modes allows endless turning.

Two turning modes

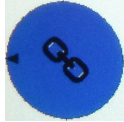

- In the **default** delivery state of the chamber, the energy chain in the azimuth turntable is **connected**. To prevent damage to the positioner and to cables that are fed through the energy chain, the NCD firmware limits the turning range from -15° to $+375^{\circ}$. The connected energy chain is indicated by the closed-chain symbol in the azimuth representation on the NCD controller's display.

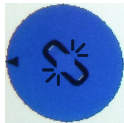

- Endless turning mode is permitted only if the energy chain is **not connected** (open-chain symbol on the display) and if **no cables are fed through** to the turntable. This handbook describes only the default state with connected energy chain.

To activate the controller

The following procedure describes activation of the NCD controller.

Prerequisite: the NCD controller is connected to the operational positioning system.

If the controller is not yet active, proceed as follows:

1. Check that the controller is connected to the mains power supply.
2. Set the power on/off switch on the rear side of the controller to the [1] (on) position.
3. Press the black standby button (labeled 5 in [Figure 7-10](#)) on the right-hand side of the front panel.
4. Wait until the system has booted.

To reference the turntable

Prerequisite: the NCD controller is activated and shows no error message. The absence of any error message means that the controller and the positioner worked correctly during the previous operation. If you are using the chamber for the first time, note that the previous operation can have been the manufacturer's final test.

If the controller outputs a "REF" message, the system requires the azimuth turntable to be referenced. To do so, proceed as follows:

1. **NOTICE!** Risk of antenna collision with the turntable's crank. If the antenna arm moves below 160° elevation (maximum is 165° , see below), the antenna mounted on the arm can collide with the turntable's crank. Such a collision typically destroys the antenna.

Make sure that the turntable's crank is removed; see [Figure 7-3](#).



2. Close the chamber door as described in [Chapter 7.3.4, "Closing the Door"](#), on page 45.

Closing the door releases the lower interlock ([Figure 4-7](#)); the positioners are no longer prevented from moving.

Release of the interlock is also indicated in the display of the NCD controller, i.e. the interlock symbol disappears; see [Figure 4-8](#).

3. Press the [REF] button on the left side of the front panel (labeled 2 in [Figure 7-10](#)).
4. Wait for the controller to complete the referencing procedure.

If no error occurs, referencing is now complete.

However, some potential scenarios can require the NCD controller to be referenced again, especially if the last positioning action was not carried out correctly. This situation can occur, for example, if there was an error during positioning, or if the turntable has moved in endless turning mode; see ["Two turning modes"](#) on page 56.

5. If the "REF" message is output after the next restart, repeat the procedure starting with [step 3](#).

Note: The elevation arm does not require referencing like the turntable because it is not designed for endless turning.

To start a positioner movement

1. If you want to move the antenna arm, proceed as described in [Chapter 7.6.1, "Moving the Elevation Positioner"](#), on page 59.
2. If you want to rotate the azimuth turntable, proceed as described in [Chapter 7.6.2, "Moving the Azimuth Turntable"](#), on page 60.
3. If you want to start combined movement of the antenna arm and azimuth turntable, proceed as described in [Chapter 7.6.3, "Combining the Elevation and Azimuth Movements"](#), on page 61.

To stop a positioner movement

- ▶ Tap the [STOP] button in the top left corner of the NCD controller; see [Figure 7-10](#).

Absolute turntable position

To control the turning positions, the chamber has an absolute position encoder and a mechanical limit switch in each positioner drive. The turntable also has a light barrier sensor:

- The **position encoders** constantly monitor the absolute position. Reference the turntable's encoder after start-up; see "To reference the turntable" on page 56. See also Chapter 9.2.1, "Positioner Loses Absolute Position", on page 72.
- The **mechanical limit switches** detect the tolerable extreme positions and prevent over-rotation. When one of these positions is reached, the switch stops the rotation and moves the positioner back to the closest default end-of-range.
- The **light barrier** in the turntable is a backup to detect the two default positions 0° and 360°, which are the recommended limits of rotation. When the light barrier is reached, the color of the positioner arrow in the controller's display briefly changes to red.

Note that before referencing, the readout of the turntable's encoder can show arbitrary values, possibly far off the physical value. Therefore, during referencing, the readout can exceed the limited turning range significantly. For example, turntable readout values >400° are possible. When the turntable reaches its mechanical limit switch during referencing, it turns 15° back in the direction of the light barrier and sets this position as 0° and 360° respectively.



Figure 7-11: During referencing, ignore the red arrows (left) and turntable angles outside of the range from -15° to +375° (right)

The following chapters describe only the most common use cases for **moving** the elevation arm or the turntable. If you are an expert user, refer to the Configuration Manual for more information on the positioning system.

- [Moving the Elevation Positioner](#).....59
- [Moving the Azimuth Turntable](#)..... 60
- [Combining the Elevation and Azimuth Movements](#).....61

7.6.1 Moving the Elevation Positioner

The elevation positioner is the antenna arm. It can rotate up to **-20°** to the front and the following maximum angle to the rear:

- If you set the NCD controller manually, the maximum rotation to the rear is limited to **+160°**.
- If you use the R&S AMS32 software for setting the angle, the elevation arm can rotate down to **+165°** to the rear. Before making this setting, make sure that you have removed the turntable's crank. See [Figure 7-3](#).

Prerequisites:

- The chamber is set up as described in [Chapter 6, "Installation and Commissioning"](#), on page 34
- The chamber is activated; see [Chapter 7.1, "Activating the Chamber"](#), on page 42.
- The NCD controller is activated; see ["To activate the controller"](#) on page 56.

To move the elevation positioner arm

1. **NOTICE!** Risk of antenna collision with the turntable's crank. If the antenna arm moves below 160° elevation (maximum is 165°, see below), the antenna mounted on the arm can collide with the turntable's crank. Such a collision typically destroys the antenna.

Make sure that the turntable's crank is removed; see [Figure 7-3](#).



2. Close the chamber door as described in [Chapter 7.3.4, "Closing the Door"](#), on page 45.

Closing the door releases the lower interlock ([Figure 4-7](#)); the positioners are no longer prevented from moving.

Release of the interlock is also indicated in the display of the NCD controller, i.e. the interlock symbol disappears; see [Figure 4-8](#).

3. Tap the control element **"New Angle AB1"** (antenna boom, labeled 3 in [Figure 7-10](#)).

An on-screen keypad is displayed.

4. Enter the target elevation angle for the antenna positioner arm.
5. Tap "OK" to confirm the entry.

6. Press the [START] button on the left side of the front panel (labeled 1 in [Figure 7-10](#)).

The positioner inside the chamber moves while the display continuously updates the current elevation angle.

7. Listen for unusual noises during operation.
8. If you notice unusual noises, proceed as described in [Chapter 9.2.2, "Unusual Noise from Positioner"](#), on page 72.

When the current angle has reached the target value, movement of the antenna elevation positioner arm is complete. If necessary, you can open the chamber door.

7.6.2 Moving the Azimuth Turntable

The turntable can rotate the DUT within an azimuth range of -15° to $+375^{\circ}$.

Prerequisites:

- The chamber is set up as described in [Chapter 6, "Installation and Commissioning"](#), on page 34
- The chamber is activated; see [Chapter 7.1, "Activating the Chamber"](#), on page 42.
- The NCD controller is activated; see ["To activate the controller"](#) on page 56.
- The turntable is referenced; see ["To reference the turntable"](#) on page 56.

To move the azimuth turntable

1. **NOTICE!** Risk of antenna collision with the turntable's crank. If the antenna arm is at an elevation below 160° (maximum is 165°), rotation of the turntable can cause the turntable's crank to collide with the antenna. Such a collision typically destroys the antenna.

Make sure that the turntable's crank is removed; see [Figure 7-3](#).



2. Close the chamber door as described in [Chapter 7.3.4, "Closing the Door"](#), on page 45.

Closing the door releases the lower interlock ([Figure 4-7](#)); the positioners are no longer prevented from moving.

Release of the interlock is also indicated in the display of the NCD controller, i.e. the interlock symbol disappears; see [Figure 4-8](#).

3. Tap the control element "**New Angle TT**" (turntable, labeled 4 in [Figure 7-10](#)).
An on-screen keypad is displayed.

4. Enter your target azimuth angle for the DUT turntable.

5. Tap "OK" to confirm your entry.

6. Press the [START] button on the left side of the front panel (labeled 1 in [Figure 7-10](#)).

The turntable inside the chamber moves, while the display continuously updates the current azimuth angle.

7. Listen for unusual noise during operation.

8. If you notice unusual noise, proceed as described in [Chapter 9.2.2, "Unusual Noise from Positioner"](#), on page 72.

When the current angle has reached the target value, moving the DUT turntable is completed. If necessary, you can open the chamber door.

For manually lifting or lowering the turntable, see ["To move the DUT to a higher or lower position"](#) on page 46.

7.6.3 Combining the Elevation and Azimuth Movements

The elevation positioner can rotate from -20° to $+165^{\circ}$; see [Chapter 7.6.1, "Moving the Elevation Positioner"](#), on page 59

At the same time, the azimuth turntable can rotate from -15° to $+375^{\circ}$.

Prerequisites:

- The chamber is set up as described in [Chapter 6, "Installation and Commissioning"](#), on page 34
- The chamber is activated; see [Chapter 7.1, "Activating the Chamber"](#), on page 42.
- The NCD controller is activated; see ["To activate the controller"](#) on page 56.
- The turntable is referenced; see ["To reference the turntable"](#) on page 56.

To move the azimuth turntable

1. **NOTICE!** Risk of antenna collision with the turntable's crank. If the antenna arm is at an elevation below 160° (maximum is 165°), rotation of the turntable can cause the turntable's crank to collide with the antenna. Such a collision typically destroys the antenna.

Make sure that the turntable's crank is removed; see [Figure 7-3](#).



2. Close the chamber door as described in [Chapter 7.3.4, "Closing the Door"](#), on page 45.

Closing the door releases the lower interlock ([Figure 4-7](#)); the positioners are no longer prevented from moving.

Release of the interlock is also indicated in the display of the NCD controller, i.e. the interlock symbol disappears; see [Figure 4-8](#).

3. Tap the control element "**New Angle AB1**" (antenna boom, labeled 3 in [Figure 7-10](#)).

An on-screen keypad is displayed.

4. Enter the target elevation angle for the antenna positioner arm.

5. Tap "OK" to confirm the entry.

6. Tap the control element "**New Angle TT**" (turntable, labeled 4 in [Figure 7-10](#)).

An on-screen keypad is displayed.

7. Enter the target azimuth angle for the DUT turntable.

8. Tap "OK" to confirm the entry.

9. Press the [START] button on the left side of the front panel (labeled 1 in [Figure 7-10](#)).

The positioners inside the chamber move while the display continuously updates the current azimuth and elevation angles.

10. Listen for unusual noises during operation.

11. If you notice unusual noises, proceed as described in [Chapter 9.2.2, "Unusual Noise from Positioner"](#), on page 72.

When the current angle has reached the target value, movement of the DUT turntable is complete. If necessary, you can open the chamber door.

For manually lifting or lowering the turntable, see ["To move the DUT to a higher or lower position"](#) on page 46.

7.7 Preparing for Shift End

Between usage periods, do the following:

1. Open the chamber door. See [Chapter 7.3.3, "Opening the Door"](#), on page 45.
Opening the door relieves the load on the gasket, thus maintaining its RF shielding efficiency; see [Chapter 5.4, "Storage"](#), on page 32.
2. Deactivate the chamber. See [Chapter 7.2, "Deactivating the Chamber"](#), on page 42.

8 Inspection and Maintenance

Familiarize yourself with residual risks and potentially dangerous situations.

See [Chapter 2.2, "Residual Risks"](#), on page 11 and [Chapter 2.3, "Potentially Dangerous Situations"](#), on page 13.

The chamber has no factory default settings.

- [Recommended Intervals](#)..... 64
- [Regular Safety Inspections](#)..... 64
- [Preparing the Chamber for Maintenance](#)..... 65
- [Performing Maintenance Tasks](#)..... 65

8.1 Recommended Intervals

To ensure safe operation and to retain the functional readiness and long operational life of the chamber, perform the inspection and maintenance tasks according to the schedule:

Table 8-1: Inspection and maintenance schedule

Maintenance interval	Maintenance tasks
Daily	"Daily safety check" on page 64 Chapter 8.4.1, "Daily Functional Check" , on page 65
Weekly	Chapter 8.4.2, "Checking the Absorber" , on page 66 Chapter 8.4.4, "Lubricating the Turntable's Telescopic Tube" , on page 68
Every 100 000 cycles	Chapter 8.4.3.1, "Cleaning the Gasket" , on page 67
As necessary	Chapter 8.4.3.2, "Cleaning the Chamber" , on page 67
Whenever test instruments are calibrated	Chapter 8.4.5, "System Calibration" , on page 69
Yearly (recommended)	"Yearly safety check" on page 65

The intervals in [Table 8-1](#) are recommended for an operating time of 160 hours per month. If you operate the chamber for longer, adapt the maintenance intervals accordingly.

8.2 Regular Safety Inspections

Daily safety check

- ▶ Before operation, test the door's interlock systems.

The test ensures that the interlocks are functioning properly. See [Chapter 6.7, "Testing Safety Systems"](#), on page 40.

Yearly safety check

This check is restricted to Rohde & Schwarz [service personnel](#).

Due to normal wear, the performance of any system can degrade over time. This performance degradation can also impair system safety. To prevent any risks, we recommend a regular safety and performance check of the chamber once a year.

8.3 Preparing the Chamber for Maintenance

Before carrying out any of the maintenance tasks described in [Chapter 8.4, "Performing Maintenance Tasks"](#), on page 65, perform the following steps.

1. Make sure that nobody uses the chamber during maintenance.
Take the steps stipulated at your company to prevent use of the chamber.
2. Open the door; see [Chapter 7.3.3, "Opening the Door"](#), on page 45.
3. Deactivate the chamber as described in [Chapter 7.2, "Deactivating the Chamber"](#), on page 42.
Deactivation prevents any positioner movement that can lead to injuries during maintenance activities.
4. If you need to move the chamber to a different location for maintenance, follow the instructions in [Chapter 5.1, "Moving the Chamber"](#), on page 28.

8.4 Performing Maintenance Tasks

The recommended intervals are listed in [Table 8-1](#).

8.4.1 Daily Functional Check

To check the door's gasket

1. Check the door's gasket for soiling, damage and wear. For information on prolonging the service life of the gasket, see [Chapter 5.4, "Storage"](#), on page 32.
2. If the gasket is soiled, clean it as described in [Chapter 8.4.3.1, "Cleaning the Gasket"](#), on page 67.
3. If the gasket has visible damage or wear, contact Rohde & Schwarz to have it replaced; see [Chapter 9.3, "Contacting Customer Support"](#), on page 73.

To check the interior of the chamber

1. Make sure that no foreign objects or dirt are on the positioners.
2. Make sure that all cables are routed properly.
Proper routing prevents the cables from impeding movement of the positioners.

To check that the antennas, cables and connectors are functioning properly

This check is restricted to an [expert user](#).

1. Perform a calibration measurement as described in the application note "[Passive Antenna Measurement and Nearfield - Farfield Transformation](#)".
2. If one or both antennas, cables or connectors do not seem to function properly, open the door; see [Chapter 7.3.3, "Opening the Door"](#), on page 45.
3. Deactivate the chamber as described in [Chapter 7.2, "Deactivating the Chamber"](#), on page 42.
4. Check the antenna-to-cable connections and the cable-to-feedthrough connections.
5. Close the chamber.
6. Check again that the antennas, cables and connectors are functioning properly.
7. If these components are still not functioning properly, proceed as follows:
 - a) If you locate the fault in one or more individual antennas or cables that can be replaced by an [expert user](#), ask an [expert user](#) to replace them.
 - b) If you are unable to locate the fault, inform Rohde & Schwarz [Service](#).

8.4.2 Checking the Absorber

This check is restricted to [maintenance personnel](#).

To check the absorber material

1. Check the absorber material inside the chamber for damage or wear, especially near the door opening.
2. If the absorber material has visible damage or wear, contact Rohde & Schwarz to have it replaced; see [Chapter 9.3, "Contacting Customer Support"](#), on page 73.

8.4.3 Cleaning

- [Cleaning the Gasket](#).....67
- [Cleaning the Chamber](#)..... 67

8.4.3.1 Cleaning the Gasket

The contact surface of the gasket can become soiled, for example through sweat or grease from fingerprints. Clean the gasket every 100 000 cycles to maintain RF shielding.

To clean the door's gasket

1. Open the door as described in [Chapter 7.3.3, "Opening the Door"](#), on page 45.
2. Deactivate the chamber as described in [Chapter 7.2, "Deactivating the Chamber"](#), on page 42.
3. Use the following cleaning equipment and materials:
 - Soft, lint-free cleaning cloth
 - Alcohol
 - Soft brush
4. Carefully use the dry soft brush to pre-clean the gasket.
5. Carefully use the cloth and alcohol to remove any soiling from the gasket's nickel-coated contact surface.
6. Optionally, activate the chamber as described in [Chapter 7.1, "Activating the Chamber"](#), on page 42.

8.4.3.2 Cleaning the Chamber

If the inside or outside of the chamber is soiled, clean it.

To clean the chamber

1. If you want to clean only the outside, you can leave the chamber closed. Otherwise, open the door as described in [Chapter 7.3.3, "Opening the Door"](#), on page 45.
2. Deactivate the chamber as described in [Chapter 7.2, "Deactivating the Chamber"](#), on page 42.
If you want to clean only the outside, proceed to [step 4](#).
3. Clean the interior of the chamber with a vacuum cleaner.
Operate the vacuum cleaner at a low power setting and move its nozzle carefully to avoid damaging the absorber material in the chamber.
4. **NOTICE!** Do not use liquid cleaning agents such as contact spray. Liquid agents can cause electrical interfaces and mechanical parts to malfunction or to be damaged.
Clean the outside of the chamber with a dry cloth.
Do not touch the gasket.
5. Optionally, activate the chamber as described in [Chapter 7.1, "Activating the Chamber"](#), on page 42.

8.4.4 Lubricating the Turntable's Telescopic Tube

This task is restricted to the [maintenance personnel](#).

The crank-driven telescopic tube for DUT height adjustment in the chamber's azimuth turntable system requires regular lubrication.

- If you notice that the crank drive does not operate smoothly, apply lubricant immediately instead of weekly.
- If you use the height adjustment infrequently, lubrication on a monthly basis can be sufficient.

We recommend using a synthetic PTFE (polytetrafluoroethylene, Teflon) ceramic oil spray or a bonding dry film lubricant. You can use, for example, [Lube TF](#) from Interflon or similar. The PTFE ceramic oil spray [Teflux](#) from Normfest is also ideally suited. However, it is not included in the delivery due to restrictions regarding air transport.

To apply ceramic oil spray to the telescopic tube

1. Open the door; see [Chapter 7.3.3, "Opening the Door"](#), on page 45.
2. Deactivate the chamber as described in [Chapter 7.2, "Deactivating the Chamber"](#), on page 42.
3. Release the clamping screw; see ["To move the DUT to a higher or lower position"](#) on page 46.
4. Insert the turntable's crank ([Figure 7-3](#)) into the hexagonal socket (labeled 3 in [Figure 7-2](#)).
5. Move the telescopic tube to its highest position.
To do so, turn the crank.
6. Hold a sheet of paper behind the telescopic tube.
The paper can catch oil spray that misses the tube.
7. Hold the spray bottle as recommended in its instructions for use.
8. Direct its nozzle toward the middle part of the telescopic tube.



9. Apply one short squirt of oil spray from one side.
10. Repeat this procedure from the opposite side of the telescopic tube.
11. Optionally, activate the chamber as described in [Chapter 7.1, "Activating the Chamber"](#), on page 42.

8.4.5 System Calibration

This activity is restricted to the [calibration appointee](#).

When the test system's instruments to which the chamber is connected are calibrated, make sure that the chamber is included in this calibration procedure. Calibration is performed typically once a year.

9 Troubleshooting and Repair

Every **user** except the **operator** is allowed to perform the activities described in this chapter. **Repair** activities are allowed for Rohde & Schwarz **service personnel** only.

For information on shipping, see [Chapter 5, "Transportation, Handling and Storage"](#), on page 28.

- [Chamber Troubleshooting](#).....70
- [Positioner Troubleshooting](#)..... 72
- [Contacting Customer Support](#).....73

9.1 Chamber Troubleshooting

To enable the automatic fuse

If the chamber's automatic fuse (circuit breaker) is triggered due to positioner overload, proceed as follows:

1. On the lower rear side of the chamber, remove the four Torx 10 screws securing the acrylic glass window.
2. Remove the acrylic glass window.
3. Switch the circuit breaker's lever to the left to enable power to the chamber:

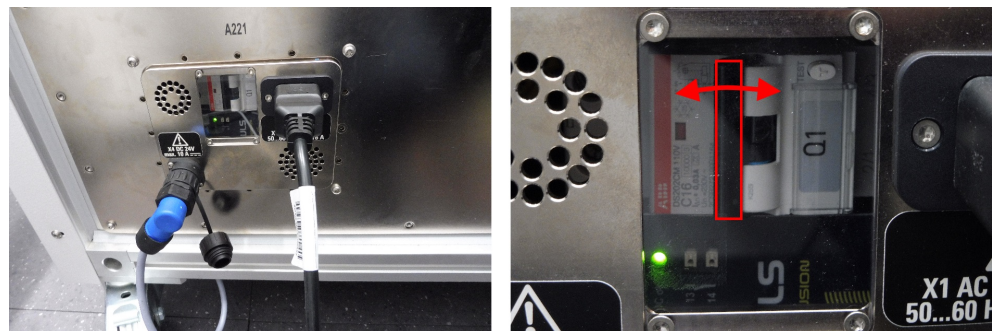

Figure 9-1: Power supply module at feedthrough [A221] (picture on the right: switch lever of the circuit breaker highlighted red)

Lever switched to the left = Power enabled

Lever switched to the right = Circuit breaker triggered, power is cut

4. Open the chamber door as described in [Chapter 7.3.3, "Opening the Door"](#), on page 45.
5. Make sure that no movable parts inside the chamber are blocked mechanically. For example, if something is blocking the positioner, operating its motor can draw an excess amount of current.
6. If you find that movable parts are blocked, remove the cause of blocking.

7. Close the chamber door.
8. Operate the chamber in the same way as you did when the circuit breaker triggered.
9. If the circuit breaker triggers again, contact Rohde & Schwarz [service](#).
10. Reattach the acrylic glass window.
11. Secure the acrylic glass window with the four Torx 10 screws.

To restore power to the chamber

If the chamber unexpectedly remains inactive, proceed as follows:

1. Check the connection to mains power.
2. If the chamber is disconnected from mains power, reconnect it.
3. If the chamber still has no power, check its circuit breaker ([Figure 9-1](#)).
4. If the circuit breaker has been triggered, check if any movable parts inside the chamber are blocked mechanically, as described in "[To enable the automatic fuse](#)" on page 70.
5. If no movable parts are blocked, switch the circuit breaker on, as described in "[To enable the automatic fuse](#)" on page 70.
6. If the chamber still has no power, check the voltage of the mains power.
7. If the mains power is not live, switch it on again.
8. If the chamber still has no power, switch the circuit breaker off and on again, as described in "[To enable the automatic fuse](#)" on page 70.
9. If the chamber still has no power, contact Rohde & Schwarz [Service](#).

To restore the door function

If you cannot open or close the door properly, proceed as follows:

1. Press the [Laser] button on the front panel so that the button's LED lights up.
2. Disconnect the mains power.
3. With the [Laser] button in its "on" position, wait until the button's LED goes out.
Waiting for this time ensures that capacitors inside the chamber's lower compartment are no longer charged.
4. Reconnect the mains power.
5. Check the door function.
The chamber performs an automatic referencing procedure for the door lock; see [Chapter 7.3.2, "Referencing the Door's Lock"](#), on page 44.
6. If the door still does not open or close properly, contact Rohde & Schwarz [Service](#).



The storage and operating temperature ranges for the R&S ATS1000 are specified in the data sheet.

9.2 Positioner Troubleshooting

- [Positioner Loses Absolute Position](#).....72
- [Unusual Noise from Positioner](#).....72

9.2.1 Positioner Loses Absolute Position

If the chamber is not connected to power and its lithium storage battery is dead, the positioners lose their absolute position information. See [Chapter 7.1, "Activating the Chamber"](#), on page 42.

To enable the position encoders of the turntable and antenna arm to restore the position information, proceed as follows:

1. Connect the chamber to power; see [Chapter 7.1, "Activating the Chamber"](#), on page 42.
2. Activate the NCD controller; see ["To activate the controller"](#) on page 56.
3. Start a referencing procedure; see ["To reference the turntable"](#) on page 56.
If the antenna arm has no position information, it is automatically included in the referencing procedure.
4. If these steps do not solve the problem, contact Rohde & Schwarz [Service](#).
We recommend that you have Rohde & Schwarz replace the lithium storage battery in the chamber.

9.2.2 Unusual Noise from Positioner

If you notice any unusual noise from the positioner, proceed as follows:

1. Stop the positioner as described in [Chapter 7.6, "Operating the Positioning System"](#), on page 55.
2. Open the door as described in [Chapter 7.3.3, "Opening the Door"](#), on page 45.
3. Make sure that your DUT and any other items in the chamber (cables, antennas) are secured properly.
4. Make sure that anything mounted on the turntable is not caught in any cables.
5. Make sure that the elevation arm is not caught in any cables.
6. If you find the cause of the unusual noise, eliminate the cause.

7. Check whether lubricating the turntable's telescopic tube eliminates the cause of the noise; see [Chapter 8.4.4, "Lubricating the Turntable's Telescopic Tube"](#), on page 68.
8. If you are unable to find the cause and the unusual noise persists, contact Rohde & Schwarz [Service](#).

9.3 Contacting Customer Support

Technical support – where and when you need it

For quick, expert help with any Rohde & Schwarz product, contact our customer support center. A team of highly qualified engineers provides support and works with you to find a solution to your query on any aspect of the operation, programming or applications of Rohde & Schwarz products.

Contact information

Contact our customer support center at www.rohde-schwarz.com/support, or follow this QR code:



Figure 9-2: QR code to the Rohde & Schwarz support page

10 Disabling and Scrapping

Every **user** except the **operator** is allowed to perform the activities described in this chapter.

Familiarize yourself with residual risks and potentially dangerous situations.

See [Chapter 2.2, "Residual Risks"](#), on page 11 and [Chapter 2.3, "Potentially Dangerous Situations"](#), on page 13.

- [Taking Out of Commission](#)..... 74
- [Disposal](#)..... 75

10.1 Taking Out of Commission

To secure the door

1. If a **DUT** or any of your equipment is still in the chamber, take it out.
2. Close the chamber door.

To label the chamber as out of commission

- ▶ If you take a defective chamber out of commission, make sure that nobody can use the chamber.
Take the steps stipulated at your company for defective equipment.

To disconnect from power and control

1. Disconnect the chamber from mains power.
The chamber is deactivated.
2. Disconnect the power cable from the chamber.
3. Store the power cable for later use.
4. Disconnect all control connections from the chamber.
5. Protect exposed fiber-optic (FO) connectors of cables using the dust caps provided.

Cover all unused FO connectors:

- On the chamber's lower rear panel
- On the NCD controller
- On the cables

10.2 Disposal

Rohde & Schwarz is committed to making careful, ecologically sound use of natural resources and minimizing the environmental footprint of our products. Help us by disposing of waste in a way that causes minimum environmental impact.

Disposing electrical and electronic equipment

A product that is labeled as follows cannot be disposed of in normal household waste after it has come to the end of its service life. Even disposal via the municipal collection points for waste electrical and electronic equipment is not permitted.



Figure 10-1: Labeling in line with EU directive WEEE

Rohde & Schwarz has developed a disposal concept for the eco-friendly disposal or recycling of waste material. As a manufacturer, Rohde & Schwarz completely fulfills its obligation to take back and dispose of electrical and electronic waste. Contact your local service representative to dispose of the product.

Glossary: List of Frequently Used Terms and Abbreviations

B

Bluetooth: A wireless mobile technology standard for radiocommunication over short distances of up to 60 m, using RF frequencies from 2.4 GHz to 2.485 GHz

C

calibration appointee: Person with technical skills and profound experience in calibrating electronic and RF systems. See also [roles](#).

chamber: The R&S ATS1000, also referred to as "the product"

D

D-Sub: Electrical D-subminiature connector, surrounded by a D-shaped metal support

DUT: Device under test

E

EMC: Electromagnetic compatibility

ESD: Electrostatic discharge

expert user: Engineer with professional experience in radiation testing of electronic components and devices. A sound knowledge of the English language is crucial. Expert users are allowed to perform the configuration tasks described in the user documentation. A member of the [service personnel](#) is allowed also to perform all tasks of an expert user. See also [roles](#).

G

gasket: A mechanical seal that, in this case, provides RF shielding.

M

maintenance personnel: Person with technical skills. Has profound experience in installing and maintaining electronic devices and pneumatic systems. See also [roles](#).

N

N connector: A ruggedized RF connector, originally developed for navy (N) applications

O

operator: Person instructed and trained to operate the chamber in well-defined procedures, mainly according to [Chapter 7, "Operation"](#), on page 42. See also [roles](#).

P

PC connector: Precision connector (not to be confused with "personal computer").

PDA: Personal digital assistant

product: The R&S ATS1000, also referred to as "the chamber"

R

R&S AREG: Radar echo generator R&S AREG100A or R&S AREG800A. Jointly addressed as R&S AREG in this handbook, if the differences of these devices are not relevant for the context.

Radio key: Car key with remote control features

RF: Radio frequency, electromagnetic oscillation in the range of 3 kHz to 300 GHz

roles: The handbook defines the following roles for performing various tasks with the chamber:

user

operator

expert user

supervisor

trainer

transportation appointee

maintenance personnel

service personnel

calibration appointee

S

service personnel: Service personnel appointed or employed by Rohde & Schwarz. A member of the service personnel is allowed also to perform all tasks of an [expert user](#). See also [roles](#).

SMA / SMP connector: SubMiniature coaxial RF connector, version A (standard) / version P (precision, pluggable)

SMD: Surface mountable device

supervisor: Expert user who instructs and supervises other users. Has leadership experience and production control expertise. See also [roles](#).

T

trainer: Expert user who trains other users. Has experience in training and instruction. See also [roles](#).

transportation appointee: Carrier with experience in using transporting equipment. Trained to handle heavy, sensitive equipment with care and without disregard for safety and health. See also [roles](#).

U

USB: Universal serial bus, industrial connector standard

user: Anyone who uses or handles the chamber during its lifecycle. Includes the operating company and its personnel, for example maintenance personnel, trainers and operators. See also [roles](#).

V

VSWR: Voltage standing wave ratio, ratio of the maximum standing wave amplitude over the minimum standing wave amplitude

W

Wi-Fi: A wireless internet-connectivity technology for electronic devices (synonym for WLAN, wireless local area network)

Index

A

Absorber check	66
Activation	42
Alpha	25
Antenna elevation arm	25
Antenna positioner	
Elevation arm	59
Risk of antenna damage	59
Application cards	9
Application notes	9
Auto-referencing of the door	44
Azimuth turntable	25, 60, 61

B

Brakes	28
Brochures	8

C

CE	7
Chamber	
Cleaning	67
Checking	35, 65
Absorber	66
Daily	65
Circuit breaker	70
Cleaning	
Chamber	67
Gasket	67
Closing the door	45
Auto-referencing procedure	44
Configuration manual	8
Connections	
Control system	39
Power source (mains)	38
Connectors	20
RF feedthrough	54
Torque recommendations	55
Control connections	39
Crank drive	
Lubrication	68
Risk of antenna damage	59, 60, 61
Customer support	73

D

Data sheets	8
Deactivation	42
Emergency	17
Documentation overview	8
Door	18
How to close	45
How to open	45
Status	43
Door operation	43
Auto-referencing procedure	44
Closing	45
Opening	45
DUT	45
Holder (metal)	48
Holder (polymer)	50, 51

DUT mounting

Metal holder set	48
PCB holder set	51
Rohacell holder	50
Telescopic holder	50
DUT positioner	25
Azimuth and elevation	61
Azimuth turntable	60

E

Electric power	70
Elevation arm	59, 61
Emergency stop	17
Epsilon	25

F

Feedthroughs	20, 54
Functional check	65
Fuse	70

G

Gasket	20, 32, 42
Cleaning	67

H

Help	9
------------	---

I

Inspection	
Intervals	64
Installing	37
Instructions handbook	8
Intended use	11
Interlock	23
Intervals	64

L

Laser	24
Lubrication	68

M

Maintenance	64
Checking	65
Intervals	64
Lubrication	68
Preparing	65
Manuals	
Configuration and adjustment	8
Help	9
Instructions handbook	8
Metal DUT holder set	48
Moving	28

O

Open source acknowledgment (OSA)	9
--	---

Opening the door	45		
Auto-referencing procedure	44		
Operating			
Antenna elevation arm	59		
Azimuth and elevation	61		
Azimuth turntable	60		
Positioning system	55		
Operating site	34		
P			
Packing	29		
Panic button	17		
Panic button (power-off switch)	38		
PCB holder set	51		
Placing a DUT	45		
Polymer DUT holder sets	50		
Positioner	20		
Troubleshooting	72		
Positioning system			
Azimuth and elevation	61		
Azimuth turntable	60		
Elevation arm	59		
Operation	55		
Referencing	55		
Power off	17, 42		
Power on	42		
Power source (mains)	38		
Power-off switch (panic button)	38		
Prerequisites for installation	34, 38		
Printed circuit board	51		
R			
Recycling	75		
Referencing of the door	44		
Referencing the positioning system	55		
Relaxation effects (gasket)	32		
RF feedthroughs	20		
RF interfaces	54		
Risks	15		
Rohacell DUT holders	50		
RoHS	8		
S			
Safety	11		
Labels	15		
Positioner	17		
Safety inspection			
Regular	64		
Shock indicators	35		
Storage	32		
System calibration			
Including chamber	69		
T			
Telescopic DUT holders	50		
Torque recommendations	55		
Transport	28, 32		
Transport crate	35		
Troubleshooting	70		
Positioner	72		
Turntable	60, 61		
Lubrication	68		
Risk of antenna damage	60, 61		
U			
Unpacking	35		
V			
Vacuum cleaner	67		
W			
WEEE	75		
Wheels	28		
White papers	9		