

R&S® RT-ZC15B Current Probe User Manual



1802995002

Version 02

ROHDE & SCHWARZ

Make ideas real



This manual describes the following Rohde & Schwarz product:

- R&S®RT-ZC15B, Current Probe (1409.8227.02)

© 2023 Rohde & Schwarz GmbH & Co. KG
Muehldorfstr. 15, 81671 Muenchen, Germany
Phone: +49 89 41 29 - 0
Email: info@rohde-schwarz.com
Internet: www.rohde-schwarz.com

Subject to change – data without tolerance limits is not binding.

R&S® is a registered trademark of Rohde & Schwarz GmbH & Co. KG.

All other trademarks are the properties of their respective owners.

1802.9950.02 | Version 02 | R&S®RT-ZC15B

The following abbreviations are used in this manual: R&S®RT-ZC15B is abbreviated as R&S RT-ZC15B.

Contents

1 Safety and regulatory information.....	5
1.1 Safety instructions.....	5
1.2 Labels on the product.....	7
1.3 Warning messages in the documentation.....	8
2 Product description.....	9
2.1 Key features.....	9
2.2 Unpacking and checking.....	10
2.3 Description of the probe.....	11
2.3.1 Probe head.....	11
2.3.2 Probe box.....	12
3 Connecting the probe.....	13
3.1 Handling the probe.....	13
3.2 Connecting the probe to the oscilloscope.....	14
3.3 Identification of the probe.....	15
3.4 Setting up and demagnetizing.....	16
3.5 Connecting the probe to the DUT.....	17
3.6 Considerations for measurements.....	18
4 Maintenance and service.....	21
4.1 Cleaning.....	21
4.2 Contacting customer support.....	21
4.3 Returning for servicing.....	22
4.4 Calibration interval.....	22
4.5 Storage and transport.....	23
4.6 Disposal.....	23

1 Safety and regulatory information

The product documentation helps you to use the product safely and efficiently. Follow the instructions provided here and in the [Chapter 1.1, "Safety instructions"](#), on page 5.

Intended use

The product is intended for the development, production and verification of electronic components and devices in industrial, administrative, and laboratory environments. Use the product only for its designated purpose. Observe the operating conditions and performance limits stated in the data sheet.

The probe is designed for usage with oscilloscopes that have a Rohde & Schwarz probe interface. Supported Rohde & Schwarz oscilloscopes are listed in the probe's data sheet.

Where do I find safety information?

Safety information is part of the product documentation. It warns you of potential dangers and gives instructions on how to prevent personal injury or damage caused by dangerous situations. Safety information is provided as follows:

- In [Chapter 1.1, "Safety instructions"](#), on page 5. The same information is provided in many languages as printed "Safety Instructions". The printed "Safety Instructions" are delivered with the product.
- Throughout the documentation, safety instructions are provided when you need to take care during setup or operation.

1.1 Safety instructions

Products from the Rohde & Schwarz group of companies are manufactured according to the highest technical standards. To use the products safely, follow the instructions provided here and in the product documentation. Keep the product documentation nearby and offer it to other users.

Use the product only for its intended use and within its performance limits. Intended use and limits are described in the product documentation such as the data sheet, manuals and the printed "Safety Instructions for Oscilloscopes and Acces-

sories" document. If you are unsure about the appropriate use, contact Rohde & Schwarz customer service.

Using the product requires specialists or specially trained personnel. These users also need sound knowledge of at least one of the languages in which the user interfaces and the product documentation are available.

Reconfigure or adjust the product only as described in the product documentation or the data sheet. Any other modifications can affect safety and are not permitted.

Never open the casing of the product. Only service personnel authorized by Rohde & Schwarz are allowed to repair the product. If any part of the product is damaged or broken, stop using the product. Contact Rohde & Schwarz customer service at <https://www.rohde-schwarz.com/support>.

In these safety instructions, the term "product" covers instruments (oscilloscopes), probes and their accessories.

Choosing the operating site

Only use the product indoors. The product casing is not waterproof. Water that enters can electrically connect the casing with live parts, which can lead to electric shock, serious personal injury or death if you touch the casing. If Rohde & Schwarz provides accessories designed for outdoor use of your product, e.g. a protective cover, you can use the product outdoors.

Unless otherwise specified in the data sheet, you can operate the product up to an altitude of 2000 m above sea level.

The product is suitable for pollution degree 2 environments where nonconductive contamination can occur. For more information on environmental conditions such as ambient temperature and humidity, see the data sheet.

Performing measurements

Take the following measures for your safety:

- Observe all voltage and current ratings of the instrument, the probes, and the accessories. Exceeding the allowed limits can lead to an electric shock. Limits and ratings are marked on the products and listed in the data sheets. Consider that the rated values depend on the frequency. The limitation curves or values are provided in the data sheet.
- Never cause any short circuits when measuring sources with high output currents.

- When working with current probes, observe the additional operating conditions specified in these safety instructions.
- Prevent the probe from receiving mechanical shock. Avoid putting excessive strain on the probe cable or exposing it to sharp bends. Touching a broken cable during measurements can cause injuries.
- Set up all probe connections to the instrument before applying power.

Working with current probes

When working with current probes, you can measure high-frequency currents or currents that contain high-frequency components.

- Switch off the test circuit while connecting the probe.
- Do not attach the clamp to bare unisolated conductors. To avoid injury from a short circuit, measure at a location on an insulated wire where the insulation is sufficient for the circuit voltage.
- Connect the probe only to the secondary side of a breaker. With this measure, you avoid injury, if a short circuit occurs.
- The following effects can cause burns and fire or damage to the measurement site:
 - Eddy current loss can cause heating of the sensor head.
 - Dielectric heating can cause heating of cord insulation and other materials.
- When measuring current that includes a high-frequency component, consider the derating characteristics of the probe. Do not measure any current that exceeds the rated current.
- Using the probes with high frequencies or strong magnetic fields may cause the device to become abnormally hot, resulting in fire, equipment damage, or burns.

1.2 Labels on the product

Labels on the casing inform about:

- Personal safety
- Product and environment safety
- Identification of the product

Table 1-1: Meaning of safety labels



	Potential hazard Read the product documentation to avoid personal injury or product damage.
	Hazardous contact voltages Do not use the probe at uninsulated live lines. Make sure to measure at sufficiently insulated conductors. This measure protects you against electric shock, electric burn, or arc flash.

Table 1-2: Labels regarding product and environment safety

	Labeling in line with EN 50419 for disposal of electrical and electronic equipment after the product has come to the end of its service life.
---	---

1.3 Warning messages in the documentation

A warning message points out a risk or danger that you need to be aware of. The signal word indicates the severity of the safety hazard and how likely it will occur if you do not follow the safety precautions.

WARNING

Potentially hazardous situation. Could result in death or serious injury if not avoided.

CAUTION

Potentially hazardous situation. Could result in minor or moderate injury if not avoided.

NOTICE

Potential risks of damage. Could result in damage to the supported product or to other property.

2 Product description

The R&S RT-ZC15B is an AC/DC current probe. It allows the user to make current measurements from DC to 50 MHz. By clamping on the conductor to be measured, the current waveform is captured easily without interrupting the electric circuit.

Since the probe is equipped with the Rohde & Schwarz probe interface, it can be connected to any Rohde & Schwarz base unit that is compatible with this interface. When connected to the front panel of a Rohde & Schwarz oscilloscope, the probe is controlled using the software of the oscilloscope.

2.1 Key features

The R&S RT-ZC15B is an AC/DC current probe. It allows the user to make current measurements from DC to 50 MHz. By clamping on the conductor to be measured, the current waveform is captured easily without interrupting the electric circuit.

Since the probe is equipped with the Rohde & Schwarz probe interface, it can be connected to any Rohde & Schwarz base unit that is compatible with this interface. When connected to the front panel of a Rohde & Schwarz oscilloscope, the probe is controlled using the software of the oscilloscope.

The key features of the probe are the following:

- Highly accurate current detection.
- Easy current measurement without interrupting the electric circuit.
- Broadband frequency characteristics DC to 50 MHz.
- Permits measurement of low current levels.
- Easy protection function to avoid self-heating during excessive input.
- Unique thin film Hall effect element.
- Rohde & Schwarz probe interface:
 - Powered by the oscilloscope - no need for an additional power supply
 - Remotely controlled by the oscilloscope

2.2 Unpacking and checking

1. Unpack the product carefully.
2. Retain the original packing material. Use it when transporting or shipping the product later.
3. Using the delivery notes, check the equipment for completeness.
4. Check the equipment for damage.

If the delivery is incomplete or equipment is damaged, contact Rohde & Schwarz.

Delivery notes

The delivery contains the following items:

- User manual
- Carrying case
- R&S RT-Zxx high-voltage and current probes data sheet
- Safety instructions for oscilloscopes and accessories (multilingual)
- Calibration certificate
- Documentation of calibrated values

2.3 Description of the probe

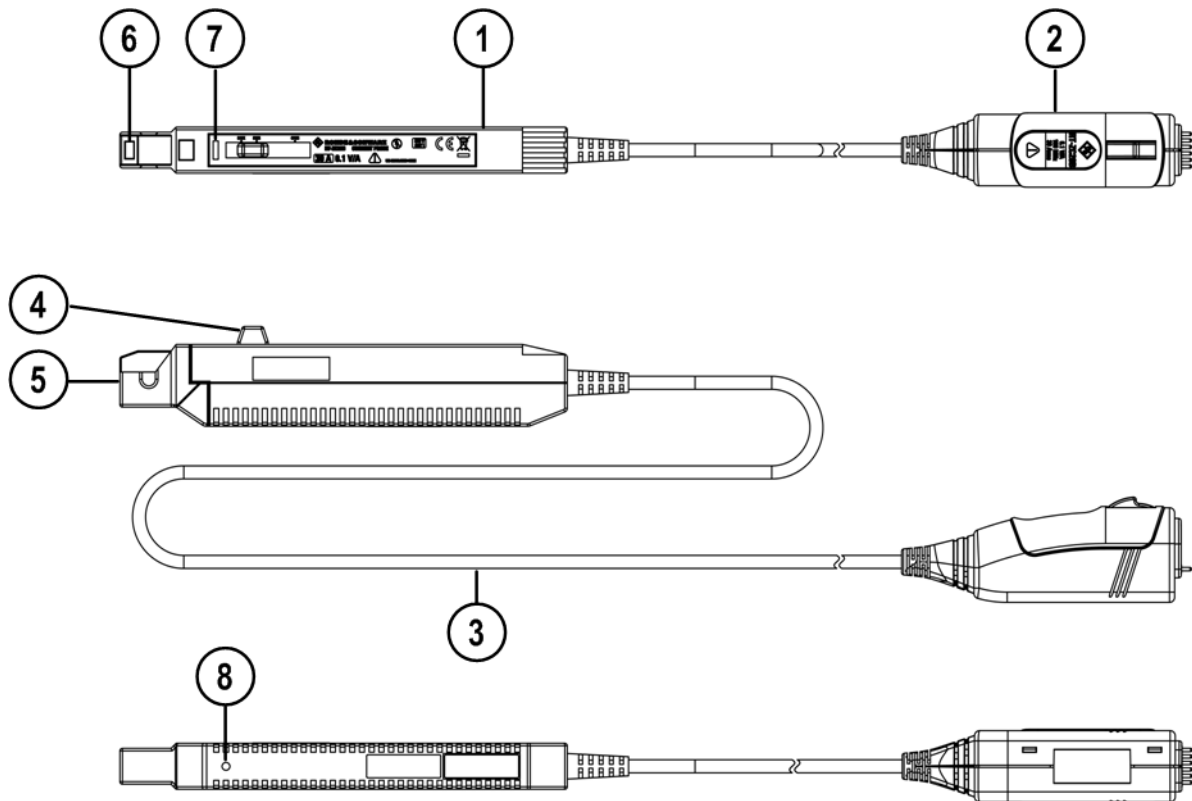

Figure 2-1: Overview of the R&S RT-ZC15B current probe

- 1 = Sensor
- 2 = Probe box
- 3 = Sensor cable
- 4 = Opening lever
- 5 = Sensor head
- 6 = Current direction indication
- 7 = UNLOCK indication
- 8 = Coarse adjustment trimmer

2.3.1 Probe head

The probe head consists of the following parts:

Opening lever

Operating lever for opening the sensor head. Always use this lever to open the sensor head.

Sensor head

The sensor head clamps on the conductor being measured, and carries out the actual current measurement. It is a precision assembly including a molded component, a ferrite core, and a Hall effect element. It may be damaged if subjected to sudden changes in ambient temperature, or mechanical strain or shock, and therefore great care should be exercised in handling it.

See also "[Handling the sensor head](#)" on page 13.

Coarse adjustment trimmer

Use this only when adjustment is not possible within the range of the zero adjustment. Use a nonconductive screwdriver (e.g. ceramic driver) for adjustment.

2.3.2 Probe box

The probe box connects the probe and the oscilloscope via the Rohde & Schwarz probe interface. The Rohde & Schwarz probe interface contains a male precision 7 mm (276 mil) BNC connector and six pogo pin connectors. This interface provides the required supply voltage and is also used to transmit analog signals and digital data simultaneously. All the analog voltages required by the probe are generated in the probe box.

The BNC connector is a precision component designed to reach a much higher frequency limit when connected to an instrument with Rohde & Schwarz probe interface.

Connect the probe only to an instrument with Rohde & Schwarz probe interface. Never connect it to a usual BNC jack, because this can damage the probe interface.

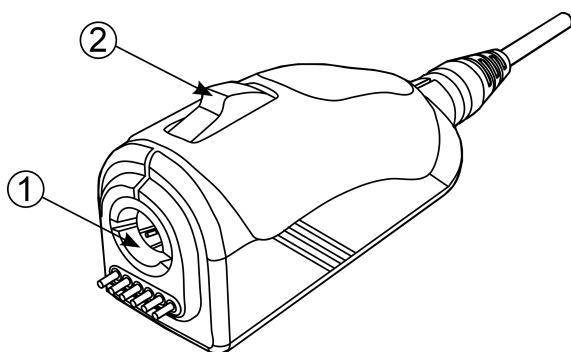

- (1) Rohde & Schwarz probe interface with 7 mm (276 mil) coaxial connector and 6 pogo pins
- (2) Release knob

3 Connecting the probe

3.1 Handling the probe

The R&S RT-ZC15B can withstand a moderate amount of physical and electrical stress. To avoid damage, treat the probe with care:

- Prevent the probe from receiving mechanical shock.
- This device should be installed and operated indoors only, between 0°C and 40°C (32°F to 104°F) and 80% RH or less.
- Avoid strain on the probe cable and route it carefully. Keep the cable away from heat sources, as bare conductors could be exposed if the insulation melts.
- Do not spill liquids on the probe.

Handling the sensor head

The sensor head is a precision assembly including a molded component, a ferrite core, and a Hall effect element. To avoid damage, treat it with care:

- Do not subject it to sudden changes in ambient temperature.
- If the mating surfaces are scratched, performance may be impaired. Prevent the mating surfaces of the sensor head from being scratched:
 - Keep the sensor head closed when not in use, to avoid accumulating dust or dirt.
 - Measurements are degraded by dirt on the mating surfaces of the sensor head, so keep the surfaces clean by gently wiping with a soft cloth.
 - Keep the clamp jaws and core slits free from foreign objects, which could interfere with clamping action.
 - When the power is on, keep the core section of the sensor closed, except when clamping it onto the conductor to be measured. The mating surface of the core section can be scratched while it is open.

Electromagnetic compatibility

The electromagnetic compatibility (EMC) class indicates where you can operate the product. The product is rated in EMC class B, see also data sheet under "General data".

Connecting the probe to the oscilloscope

Class B equipment is suitable for use in:

- Residential environments
- Environments that are directly connected to a low-voltage supply network that supplies residential buildings

3.2 Connecting the probe to the oscilloscope

 The output of the probe is terminated internally. Use an Rohde & Schwarz oscilloscope with high impedance inputs. Accurate measurement is not possible with an impedance of 50 Ω .

The probe is designed for usage with oscilloscopes that have a Rohde & Schwarz probe interface. Supported Rohde & Schwarz oscilloscopes are listed in the probe's data sheet.

1. **NOTICE!** Risk of circuit damage. When the current probe is connected, a demagnetizing waveform is initially applied to the core. Rohde & Schwarz oscilloscopes demagnetize the probe automatically when the probe is connected to the instrument.

Check that the conductor being measured is not clamped when connecting the R&S RT-ZC15B to the oscilloscope.

2. **NOTICE!** Risk of damaging the probe. Connect the probe only to an instrument with Rohde & Schwarz probe interface. Never connect it to a usual BNC jack, because this can damage the probe interface.

Connect the probe box (1) to the Rohde & Schwarz probe interface of the oscilloscope (2).

The probe snaps in when connected properly to the port.

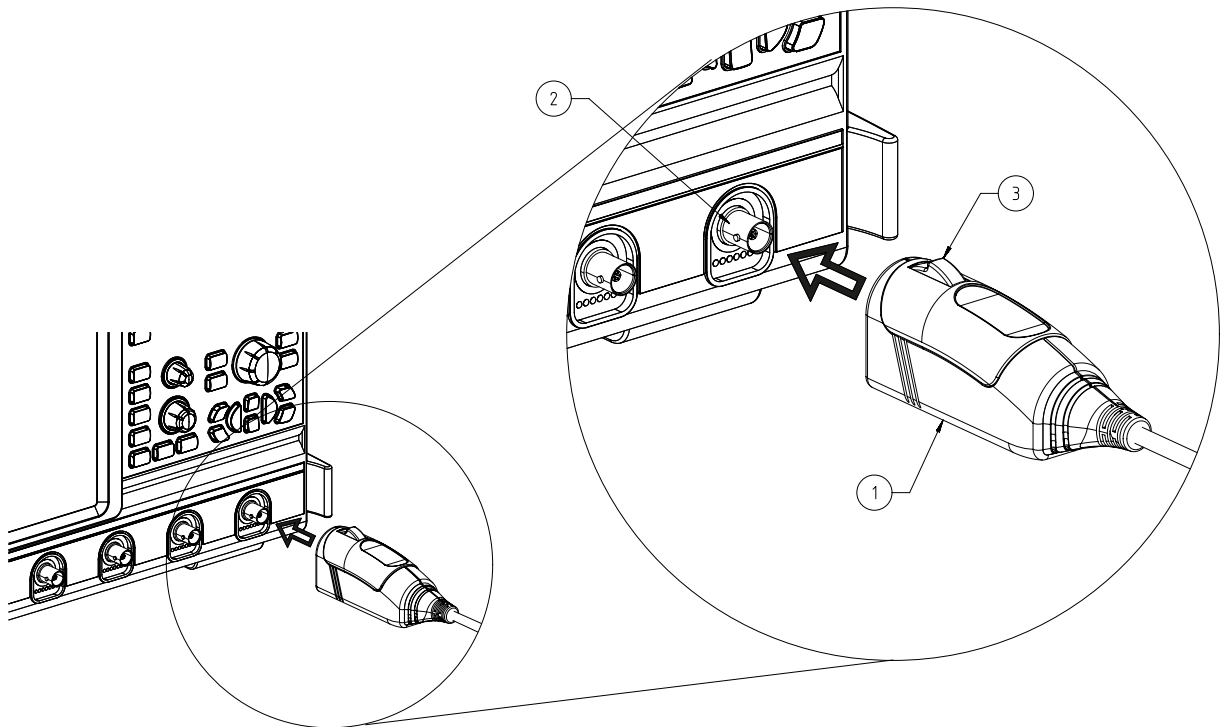

Figure 3-1: Connecting the probe to the Rohde & Schwarz oscilloscope

- ▶ To disconnect the probe:
 - a) Press and hold the release button (3).
 - b) Pull the probe box away from the oscilloscope.

3.3 Identification of the probe

When the probe is connected to the oscilloscope, the oscilloscope recognizes the probe and reads out the probe-specific parameters.

The oscilloscope settings for attenuation and offset are automatically adjusted; and the oscilloscope switches to high impedance coupling (1 M Ω) to ensure accurate measurements.

The complete probe information is shown in the probe settings dialog. For more information, refer to the user manual of your oscilloscope.

3.4 Setting up and demagnetizing

Before starting measurements, demagnetizing the core and a zero adjustment of the probe are required.

To demagnetize and zero-adjust the probe:

1. Connect the R&S RT-ZC15B current probe as described in [Connecting the probe to the oscilloscope](#).
2. **NOTICE!** Risk of circuit damage. Demagnetizing causes current to flow into the conductor, which may damage parts in the circuit to be measured. Do not demagnetize while the R&S RT-ZC15B is clamping a conductor to be measured.

Make sure that there is no conductor in the sensor aperture.

3. **NOTICE!** Risk of instrument damage. When opening and closing the sensor head of the probe, be sure to operate with the opening lever. If an upper core is forced to open when the sensor head is locked, the open-close mechanism can be damaged.

Press the opening lever until the UNLOCK indication disappears. Close the sensor head properly.

4. On the oscilloscope, navigate to the probe settings. For more information, refer to the user manual of your oscilloscope.
5. Select the channel the probe is connected to.
6. Tap "DeGauss".

This demagnetizes the core if it has been magnetized by switching the power on and off, or by an excessive input. Always carry out demagnetizing before measurement.

The demagnetizing process takes about one second. During demagnetizing, a demagnetizing waveform is present at the output.

7. Change the "Zero adjust" value to adjust the waveform to zero position. After demagnetizing always carry out a zero adjustment.

Tip: Some Rohde & Schwarz oscilloscopes provide a "Detect AutoZero" function to demagnetize and adjust to zero position in one step.

Tip: You can save the zero adjust value in the probe box. If you connect the probe to another channel or to another appropriate Rohde & Schwarz oscilloscope, the value is read out again.

Connecting the probe to the DUT

8. If zero adjustment is not possible, turn the coarse adjustment trimmer to bring the waveform within the range of zero adjustment (see [figure 2-1 on page 11](#)).

3.5 Connecting the probe to the DUT

1. Check that the system is safe, and that the preparations described in the preceding sections have been carried out.
2. Pull the sensor slider, so that the clamp opens.

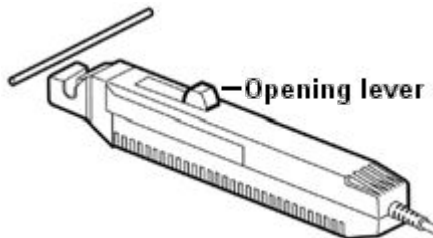

3. Align the sensor so that the current direction indication matches the direction of current flow through the conductor that you measure. The conductor should be in the center of the clamp aperture because the measurement may be affected by the position within the clamp aperture of the conductor being measured.
4. Press the opening lever until the UNLOCK indication disappears. Make sure that the sensor head is properly closed.

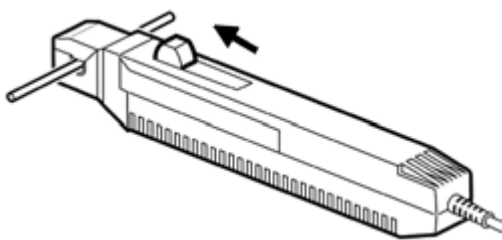

If the sensor head is not properly closed, accurate measurement is not possible.

3.6 Considerations for measurements

Measurements of continuous input current

To avoid damage to the probe when doing measurements of continuous input current, consider the following:

- The maximum continuous input range is based on heat that is internally generated during measurement. It varies according to the frequency of the current being measured. Refer to the data sheet "R&S RT-Zxx high voltage and current probes".
- The device may sustain damage from self-heating even at current levels that are lower than the maximum rated current. The maximum rated current is a recommended value that assumes sine-wave input under standard conditions. Self-heating may happen if the ambient temperature increases or the measurement current waveform contains other frequency components.
- If the input current exceeds a certain level, generated heat activates a built-in safety function that blocks normal output. If this happens, remove the input immediately (remove the sensor from the conductor being measured, or reduce the input current to zero). Wait until the sensor has had sufficient time to cool before resuming operation.
Continuous input of current exceeding the rated maximum or repeated activation of the safety function may result in damage to the device.
- Even if the input current does not exceed the rated continuous maximum current, continuous input for an extended period of time may result in activation of the safety circuit to prevent damage resulting from heating of the sensor. At high ambient temperatures, the built-in safety circuit may activate at current input levels below the rated continuous maximum current.
- Current measurement exceeding approx. 1 kHz may result in temperature rise on the sensor-head. This is attributed to excitation loss that cannot be prevented due to natural physical principles. Be careful to avoid injury, electric shock due to short-circuits, or damage to the device that may be caused by the increased temperature.
- Do not place any unclamped conductor with an electric current of a frequency of 10 kHz or more near the sensor head. Current flowing in the conductor nearby may heat up the sensor head and cause its temperature to rise, leading to damage to the sensor. For example, when one side of a go-and-return conductor is clamped and the other side is also placed near the sensor head as shown in the diagram, even if the electric current is lower than the consec-

Considerations for measurements

utive maximum current, electric currents in both sides will heat up the sensor and raise the temperature, thereby causing damage to the sensor.

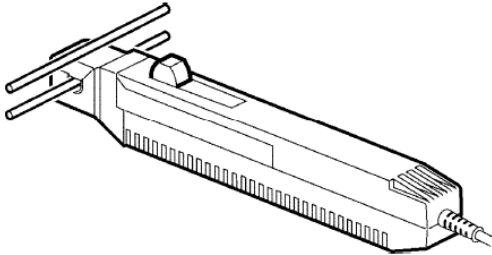
**Drift, oscillation, and sound**

- Immediately after powering on, the probe may be subject to an appreciable offset drift due to the effect of self-heating. Therefore, warm up the probe for about 30 minutes before carrying out measurements.
- When performing continuous measurements, be aware that the offset voltage drifts, depending on factors such as the ambient temperature.
- Under certain circumstances, oscillation may occur while the power supply is on. This does not indicate a malfunction. Oscillation can be stopped and operation restored to normal by opening and closing the sensor head.
- Acoustic resonance can occur depending on the amplitude and frequency of the measured current. This sound may also occur during demagnetizing operation, but it is not a malfunction or probe failure.

If a foreign substance such as dust is present on the contact surfaces of the sensor head, a slight gap can occur between the upper and lower sensors, and a resonant sound may be emitted. Clean the sensors as described in this manual to ensure correct measurements.

- An increasing volume of the resonant sound during use may indicate that the gap between the upper and lower sensors has increased. Since the sensor characteristics may change, it is recommended to calibrate the device.

Considerations for measurements

- i** At high frequencies, common mode noise may affect measurements taken on the high-voltage side of circuits. If this occurs, reduce the frequency range of the waveform measuring instrument, or clamp onto the low-voltage side of the circuit, as appropriate.

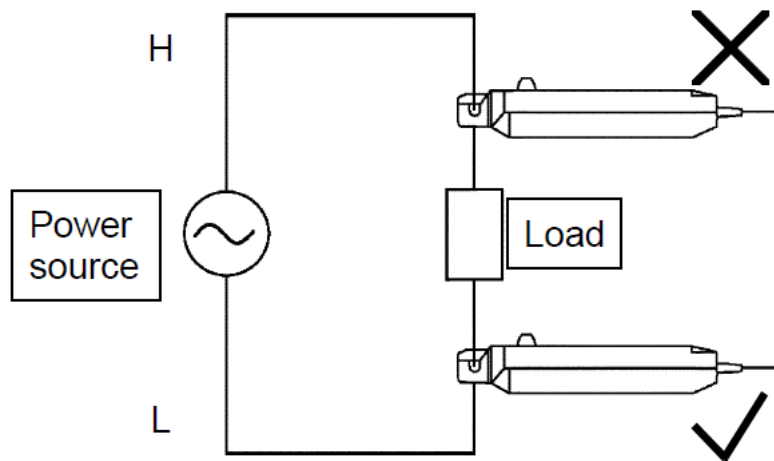

4 Maintenance and service

If service or calibration is needed, contact your Rohde & Schwarz service center. Return a defective product to the Rohde & Schwarz service center for diagnosis and exchange.

4.1 Cleaning

1. Discharge any static electricity at your hands before cleaning the facing surfaces of the sensor head.

Thus, you ensure that no high voltage caused by static electricity is applied to the product. Application of a high voltage can damage the internal Hall elements or circuitry. You can attract static electricity to your hands by touching a nearby metal object.

2. Clean the outside of the product using a soft cloth moistened with either distilled water or isopropyl alcohol. Keep in mind that the casing is not waterproof.
Note: Do not use cleaning agents. Solvents (thinners, acetone), acids and bases can damage the labeling or plastic parts.
3. Dry the product completely before using it.

4.2 Contacting customer support

Technical support – where and when you need it

For quick, expert help with any Rohde & Schwarz product, contact our customer support center. A team of highly qualified engineers provides support and works with you to find a solution to your query on any aspect of the operation, programming or applications of Rohde & Schwarz products.

Contact information

Contact our customer support center at www.rohde-schwarz.com/support, or follow this QR code:



Figure 4-1: QR code to the Rohde & Schwarz support page

4.3 Returning for servicing

Use the original packaging to return your R&S RT-ZC15B to your Rohde & Schwarz service center. A list of all service centers is available on:

www.services.rohde-schwarz.com

If you cannot use the original packaging, consider the following:

1. Use a sufficiently sized box.
2. Protect the product from damage and moisture (e.g. with bubble wrap).
3. Use some kind of protective material (e.g. crumpled newspaper) to stabilize the product inside the box.
4. Seal the box with tape.
5. Address the package to your nearest Rohde & Schwarz service center.

4.4 Calibration interval

The recommended calibration interval for R&S RT-ZC15B current probe is one year. For servicing, send the probe to your nearest Rohde & Schwarz service center (see [Chapter 4.3, "Returning for servicing"](#), on page 22).

4.5 Storage and transport

Protect the product against dust. Ensure that the environmental conditions, e.g. temperature range and climatic load, meet the values specified in the data sheet.

Store the product in a shock-resistant case, e.g. in the shipping case.

Unless otherwise specified in the data sheet, the maximum transport altitude without pressure compensation is 4500 m above sea level.

4.6 Disposal

Rohde & Schwarz is committed to making careful, ecologically sound use of natural resources and minimizing the environmental footprint of our products. Help us by disposing of waste in a way that causes minimum environmental impact.

Disposing of electrical and electronic equipment

A product that is labeled as follows cannot be disposed of in normal household waste after it has come to the end of its life. Even disposal via the municipal collection points for waste electrical and electronic equipment is not permitted.



Figure 4-2: Labeling in line with EU directive WEEE

Rohde & Schwarz has developed a disposal concept for the eco-friendly disposal or recycling of waste material. As a manufacturer, Rohde & Schwarz completely fulfills its obligation to take back and dispose of electrical and electronic waste. Contact your local service representative to dispose of the product.